

# LA6588MC

## Single-phase Fan Motor IC, 24 V Power Supply, BTL Output Linear Drive

### Monolithic Linear IC

#### Overview

The LA6588MC is a Single-phase bipolar fan motor IC for 24 V power supply. BTL output linear drive ensures highly-efficient, energy-saving, and silent drive while suppressing the ineffective current. Lock protection and lock signal circuit are incorporated, proving most suitable for consumer equipment power supply, OA equipment and car audio system, etc which require high reliability and low noise.

#### Features

- Single-phase Full-wave Linear Drive by BTL Output (Gain Resistance 500 to 360 k $\Omega$ , 57 dB):  
No Switching Noise, which is Most Favorable for use in Equipment Requiring Silent Operation, such as Consumer Equipment Power Supply, etc.
- Operable at Low Voltage and Over a Wide Operation Voltage Range (8 to 26.4 V)
- Low Saturation Output (Upper + Lower Saturation Voltages:  $V_{Osat}(\text{total}) = 1.1 \text{ V Typ}$ ,  $I_O = 200 \text{ mA}$ ):  
High Coil Efficiency and Small Current Drain. Small Heat Generation from IC itself
- Lock Protection and Automatic Return Circuits Incorporated
- Lock Protection Signal Output (L during Rotation, H at Stop, Open Collector Output)
- Output (Rotation Detection Output: Open Collector Output)
- Hall Bias Incorporated ( $V_{HB} = 1.5 \text{ V}$ )
- Heat Protection Circuit: the Heat Protection Circuit Suppresses the Drive Current to Prevent Burn or Damage of IC when the Large Current Flows due to Output Short-circuit and the IC Chip Temperature Exceeds 180°C
- Small Package with High Heat Capacity (MFP10SK) Pin-compatible Silent Series (5 V/12 V/24 V Products)



ON Semiconductor®

[www.onsemi.com](http://www.onsemi.com)

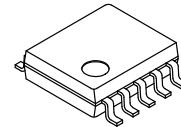

MFP10SK  
CASE 751DA

#### MARKING DIAGRAM

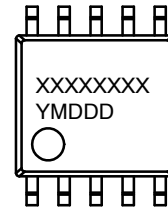

XXXX = Specific Device Code  
Y = Year  
M = Month  
DDD = Additional Traceability Data

#### PIN ASSIGNMENT

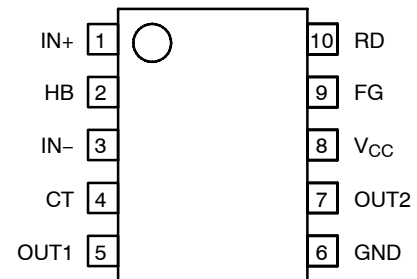

(Top View)

#### ORDERING INFORMATION

See detailed ordering and shipping information on page 5 of this data sheet.

# LA6588MC

## SPECIFICATIONS

### ABSOLUTE MAXIMUM RATINGS (T<sub>A</sub> = 25°C)

Symbol	Parameter	Conditions	Ratings	Unit
V <sub>CC</sub> max	Supply Voltage		28	V
I <sub>OUT</sub> max	Output Current		0.8	A
V <sub>OUT</sub> max	Output Withstand Voltage		28	V
V <sub>RD/FG</sub> max	Output Withstand Voltage of RD/FG Output Pin		28	V
I <sub>RD/FG</sub> max	RD/FG Output Current		5	mA
I <sub>B</sub> max	HB Output Current		10	mA
P <sub>d</sub> max	Allowable Dissipation	Mounted on a specified board (Note 1)	800	mW
T <sub>opr</sub>	Operating Temperature		-30 to +90	°C
T <sub>stg</sub>	Storage Temperature		-55 to +150	°C

Stresses exceeding those listed in the Maximum Ratings table may damage the device. If any of these limits are exceeded, device functionality should not be assumed, damage may occur and reliability may be affected.

1. Mounted on a specified board: 114.3 × 76.1 × 1.6 mm<sup>3</sup>, glass epoxy board.

**CAUTION:** Absolute maximum ratings represent the value which cannot be exceeded for any length of time.

**CAUTION:** Even when the device is used within the range of absolute maximum ratings, as a result of continuous usage under high temperature, high current, high voltage, or drastic temperature change, the reliability of the IC may be degraded. Please contact us for the further details.

### RECOMMENDED OPERATING CONDITIONS (T<sub>A</sub> = -30 to +90°C)

Symbol	Parameter	Conditions	Min	Typ	Max	Unit
V <sub>CC</sub>	Supply Voltage		8	-	26.4	V
V <sub>ICM</sub>	Common-phase Input Voltage Range of Hall Input		0	-	V <sub>CC</sub> -1.5	V

Functional operation above the stresses listed in the Recommended Operating Ranges is not implied. Extended exposure to stresses beyond the Recommended Operating Ranges limits may affect device reliability.

### ELECTRICAL CHARACTERISTICS (T<sub>A</sub> = 25°C, V<sub>CC</sub> = 24 V, unless otherwise specified)

Symbol	Parameter	Conditions	Min	Typ	Max	Unit
I <sub>CC1</sub>	Circuit Current	During drive (CT = L)	4.5	7	9.5	mA
I <sub>CC2</sub>		During lock protection (CT = H)	2.5	4.5	6.5	mA
I <sub>CT1</sub>	Lock Detection Capacitor Charge Current		2.0	2.7	3.5	μA
I <sub>CT2</sub>	Capacitor Discharge Current		0.15	0.23	0.30	μA
R <sub>CT</sub>	Capacitor Charge and Discharge Current Ratio	RCD = I <sub>CT1</sub> /I <sub>CT2</sub>	10	12	14	
V <sub>CT1</sub>	CT Charge Voltage		1.55	1.7	1.8	V
V <sub>CT2</sub>	CT Discharge Voltage		0.65	0.75	0.85	V
V <sub>OL</sub>	OUT Output L Saturation Voltage	I <sub>O</sub> = 200 mA	-	0.2	0.3	V
V <sub>OH</sub>	OUT Output H Saturation Voltage	I <sub>O</sub> = 200 mA	-	0.9	1.2	V
V <sub>HN</sub>	Hall Input Sensitivity	Zero peak value (including offset and hysteresis)	-	7	-	mV
V <sub>RD/FG</sub>	RD/FG Output Pin L Voltage	I <sub>RD/FG</sub> = 5 mA	-	0.2	0.3	V
I <sub>RD/FG</sub>	RD/FG Output Pin Leak Current	V <sub>RD/FG</sub> = 15 V	-	1	3	μA
V <sub>HB</sub>	HB Output Voltage	I <sub>HB</sub> = 5 mA	1.3	1.5	1.7	V

Product parametric performance is indicated in the Electrical Characteristics for the listed test conditions, unless otherwise noted. Product performance may not be indicated by the Electrical Characteristics if operated under different conditions.

# LA6588MC

## TRUTH TABLE

IN <sup>-</sup>	IN <sup>+</sup>	CT	OUT1	OUT2	FG	RD	Mode
H	L	L	H	L	L	L	During rotation
L	H		L	H	H		
-	-	H	OFF	OFF	-	H	During lock protection

NOTE: -: Don't care.

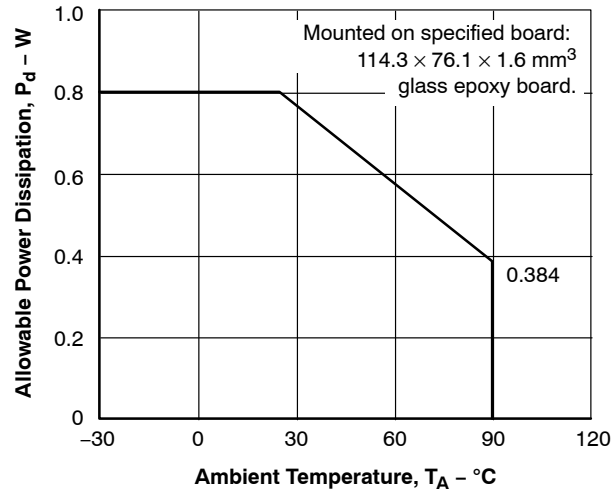

Figure 1. P<sub>d</sub> max - T<sub>A</sub>

# LA6588MC

## BLOCK DIAGRAM

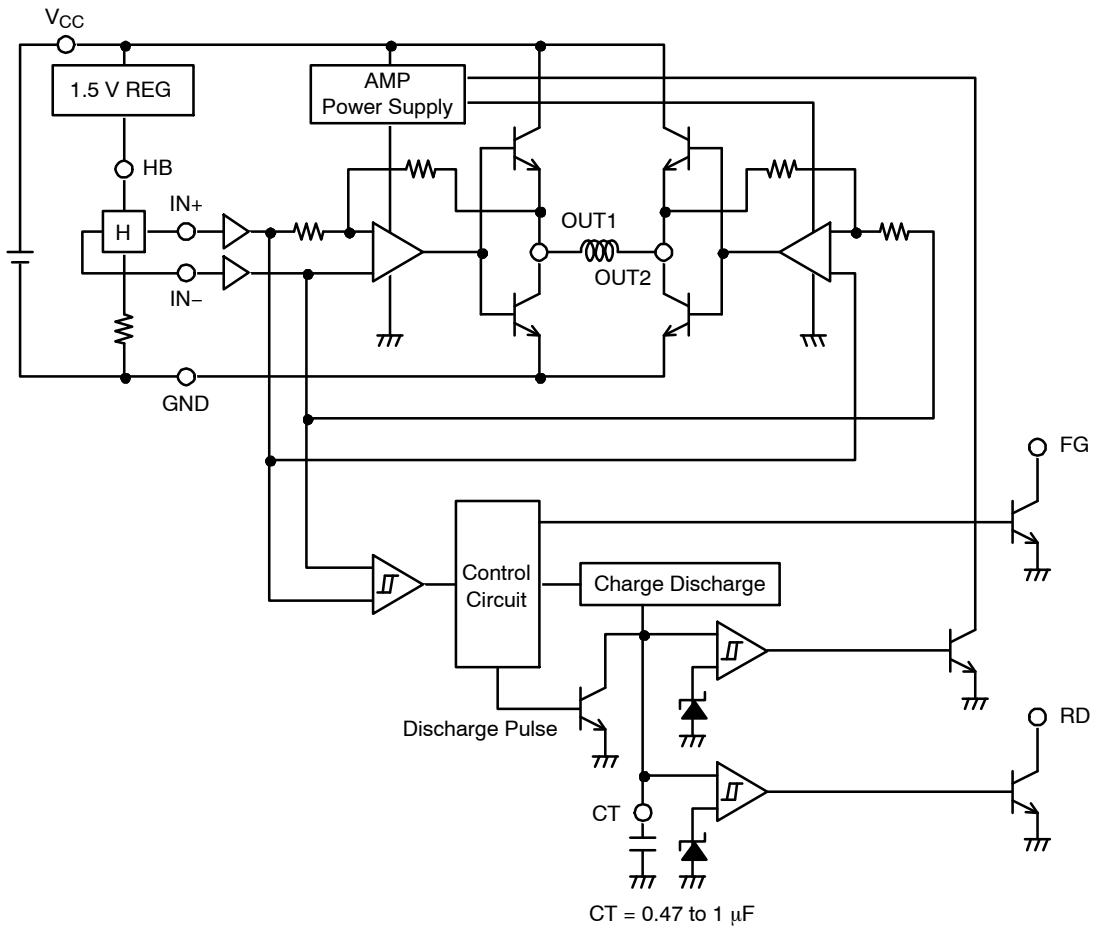
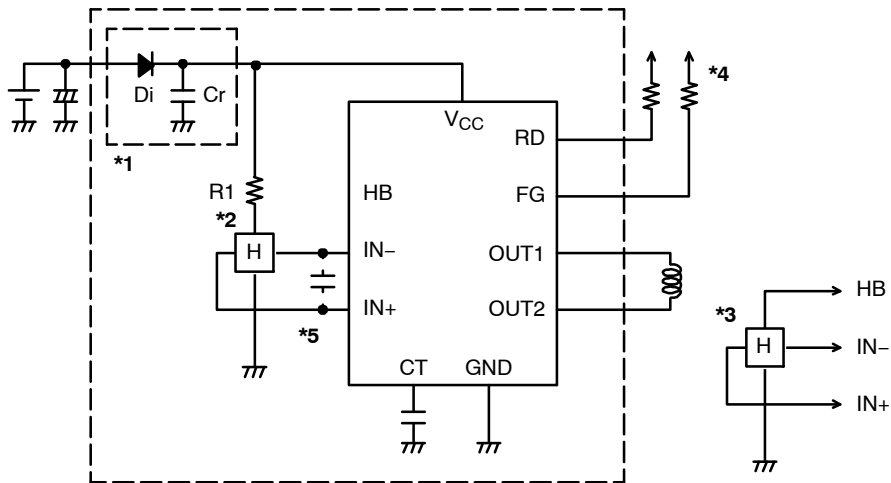

Figure 2. Block Diagram

# LA6588MC

## APPLICATION CIRCUIT EXAMPLE



**Figure 3. Application Circuit Example**

\*1: When Di to prevent breakdown in case of reverse connection is used, it is necessary to insert a capacitor Cr to secure the regenerative current route. Similarly, Cr is necessary to enhance the reliability when there is no capacitor near the fan power line.

\*2: When taking Hall bias from  $V_{CC}$ , carry out bias to  $V_{CC}$  with resistor R1 as shown in the figure. Linear drive is achieved through voltage control of the coil by amplifying the Hall output. With large Hall element output, the start performance and efficiency are improved. Noise can be reduced further by adjusting the Hall element.

\*3: When the Hall bias is taken from the HB pin, constant-voltage bias is made with about 1.5 V. Therefore, the Hall element can provide the output satisfactory in temperature characteristics.

\*4: Keep this open when not using.

\*5: When the wiring from the Hall output to IC Hall input is long, noise may be carried through the wiring. In this case, insert the capacitor as shown in the figure.

### ORDERING INFORMATION

Device	Package	Wire Bond	Shipping† (Qty / Packing)
LA6588MC-AH	MFP10SK (225mil)	Au-wire	1,000 / Tape & Reel
LA6588MC-W-AH	MFP10SK (225mil)	Cu-wire	1,000 / Tape & Reel

†For information on tape and reel specifications, including part orientation and tape sizes, please refer to our Tape and Reel Packaging Specifications Brochure, [BRD8011/D](#).

# MECHANICAL CASE OUTLINE

## PACKAGE DIMENSIONS

ON Semiconductor®



SOIC10W / MFP10SK (225 mil)  
CASE 751DA  
ISSUE A

DATE 23 OCT 2013

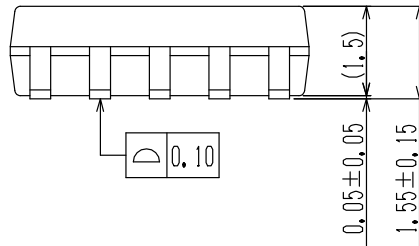
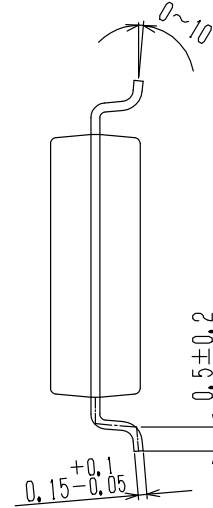
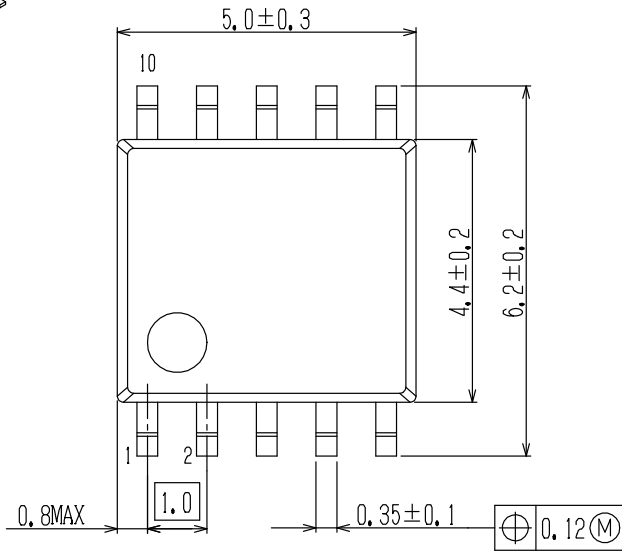
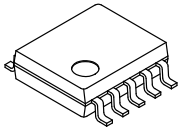

### SOLDERING FOOTPRINT\*

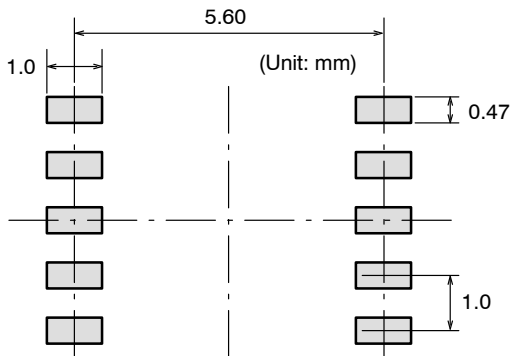

NOTE: The measurements are not to guarantee but for reference only.

\*For additional information on our Pb-Free strategy and soldering details, please download the ON Semiconductor Soldering and Mounting Techniques Reference Manual, SOLDERRM/D.

### GENERIC MARKING DIAGRAM\*

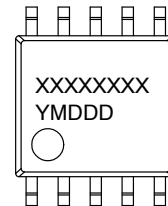

XXXX = Specific Device Code  
Y = Year  
M = Month  
DDD = Additional Traceability Data

\*This information is generic. Please refer to device data sheet for actual part marking. Pb-Free indicator, "G" or microdot "▪", may or may not be present.

DOCUMENT NUMBER:	98AON80819E	Electronic versions are uncontrolled except when accessed directly from the Document Repository. Printed versions are uncontrolled except when stamped "CONTROLLED COPY" in red.
STATUS:	ON SEMICONDUCTOR STANDARD	
NEW STANDARD:		
DESCRIPTION:	SOIC10W / MFP10SK (225 MIL)	PAGE 1 OF 2



ON Semiconductor and  are trademarks of Semiconductor Components Industries, LLC dba ON Semiconductor or its subsidiaries in the United States and/or other countries. ON Semiconductor owns the rights to a number of patents, trademarks, copyrights, trade secrets, and other intellectual property. A listing of ON Semiconductor's product/patent coverage may be accessed at [www.onsemi.com/site/pdf/Patent-Marking.pdf](http://www.onsemi.com/site/pdf/Patent-Marking.pdf). ON Semiconductor reserves the right to make changes without further notice to any products herein. ON Semiconductor makes no warranty, representation or guarantee regarding the suitability of its products for any particular purpose, nor does ON Semiconductor assume any liability arising out of the application or use of any product or circuit, and specifically disclaims any and all liability, including without limitation special, consequential or incidental damages. Buyer is responsible for its products and applications using ON Semiconductor products, including compliance with all laws, regulations and safety requirements or standards, regardless of any support or applications information provided by ON Semiconductor. "Typical" parameters which may be provided in ON Semiconductor data sheets and/or specifications can and do vary in different applications and actual performance may vary over time. All operating parameters, including "Typicals" must be validated for each customer application by customer's technical experts. ON Semiconductor does not convey any license under its patent rights nor the rights of others. ON Semiconductor products are not designed, intended, or authorized for use as a critical component in life support systems or any FDA Class 3 medical devices or medical devices with a same or similar classification in a foreign jurisdiction or any devices intended for implantation in the human body. Should Buyer purchase or use ON Semiconductor products for any such unintended or unauthorized application, Buyer shall indemnify and hold ON Semiconductor and its officers, employees, subsidiaries, affiliates, and distributors harmless against all claims, costs, damages, and expenses, and reasonable attorney fees arising out of, directly or indirectly, any claim of personal injury or death associated with such unintended or unauthorized use, even if such claim alleges that ON Semiconductor was negligent regarding the design or manufacture of the part. ON Semiconductor is an Equal Opportunity/Affirmative Action Employer. This literature is subject to all applicable copyright laws and is not for resale in any manner.

## PUBLICATION ORDERING INFORMATION

### LITERATURE FULFILLMENT:

Literature Distribution Center for ON Semiconductor  
19521 E. 32nd Pkwy, Aurora, Colorado 80011 USA  
**Phone:** 303-675-2175 or 800-344-3860 Toll Free USA/Canada  
**Fax:** 303-675-2176 or 800-344-3867 Toll Free USA/Canada  
**Email:** [orderlit@onsemi.com](mailto:orderlit@onsemi.com)

**N. American Technical Support:** 800-282-9855 Toll Free  
USA/Canada  
**Europe, Middle East and Africa Technical Support:**  
Phone: 421 33 790 2910

**ON Semiconductor Website:** [www.onsemi.com](http://www.onsemi.com)

**Order Literature:** <http://www.onsemi.com/orderlit>

For additional information, please contact your local Sales Representative