



Is Now Part of



ON Semiconductor®

To learn more about ON Semiconductor, please visit our website at
www.onsemi.com

Please note: As part of the Fairchild Semiconductor integration, some of the Fairchild orderable part numbers will need to change in order to meet ON Semiconductor's system requirements. Since the ON Semiconductor product management systems do not have the ability to manage part nomenclature that utilizes an underscore (_), the underscore (_) in the Fairchild part numbers will be changed to a dash (-). This document may contain device numbers with an underscore (_). Please check the ON Semiconductor website to verify the updated device numbers. The most current and up-to-date ordering information can be found at www.onsemi.com. Please email any questions regarding the system integration to Fairchild_questions@onsemi.com.

ON Semiconductor and the ON Semiconductor logo are trademarks of Semiconductor Components Industries, LLC dba ON Semiconductor or its subsidiaries in the United States and/or other countries. ON Semiconductor owns the rights to a number of patents, trademarks, copyrights, trade secrets, and other intellectual property. A listing of ON Semiconductor's product/patent coverage may be accessed at www.onsemi.com/site/pdf/Patent-Marking.pdf. ON Semiconductor reserves the right to make changes without further notice to any products herein. ON Semiconductor makes no warranty, representation or guarantee regarding the suitability of its products for any particular purpose, nor does ON Semiconductor assume any liability arising out of the application or use of any product or circuit, and specifically disclaims any and all liability, including without limitation special, consequential or incidental damages. Buyer is responsible for its products and applications using ON Semiconductor products, including compliance with all laws, regulations and safety requirements or standards, regardless of any support or applications information provided by ON Semiconductor. "Typical" parameters which may be provided in ON Semiconductor data sheets and/or specifications can and do vary in different applications and actual performance may vary over time. All operating parameters, including "Typicals" must be validated for each customer application by customer's technical experts. ON Semiconductor does not convey any license under its patent rights nor the rights of others. ON Semiconductor products are not designed, intended, or authorized for use as a critical component in life support systems or any FDA Class 3 medical devices or medical devices with a same or similar classification in a foreign jurisdiction or any devices intended for implantation in the human body. Should Buyer purchase or use ON Semiconductor products for any such unintended or unauthorized application, Buyer shall indemnify and hold ON Semiconductor and its officers, employees, subsidiaries, affiliates, and distributors harmless against all claims, costs, damages, and expenses, and reasonable attorney fees arising out of, directly or indirectly, any claim of personal injury or death associated with such unintended or unauthorized use, even if such claim alleges that ON Semiconductor was negligent regarding the design or manufacture of the part. ON Semiconductor is an Equal Opportunity/Affirmative Action Employer. This literature is subject to all applicable copyright laws and is not for resale in any manner.

FAN8412M/FAN8413M

2 Phase Half Wave BLDC Motor Predriver

Features

- A wide range of operation voltage: 4V to 28V
- Locked motor protection with open collector alarm out or speed out and auto retry
- Compact package: 8-SOP-225

Description

The FAN8412M/FAN8413M is a monolithic integrated circuit, and suitable for DC cooling fan motors predriver.

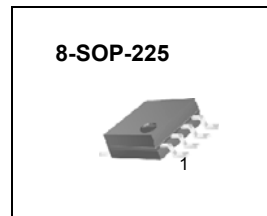

Typical Applications

- DC cooling fan motor

Ordering Information

Device	Package	Operating Temp.
FAN8412M	8-SOP-225	-40°C ~ 95°C
FAN8412MX	8-SOP-225	-40°C ~ 95°C
FAN8413M	8-SOP-225	-40°C ~ 95°C
FAN8413MX	8-SOP-225	-40°C ~ 95°C
FAN8412M_NL	8-SOP-225	-40°C ~ 95°C
FAN8412MX_NL	8-SOP-225	-40°C ~ 95°C
FAN8413M_NL	8-SOP-225	-40°C ~ 95°C
FAN8413MX_NL	8-SOP-225	-40°C ~ 95°C

Note

X : Tape & Reel

NL : Lead Free

Block Diagram

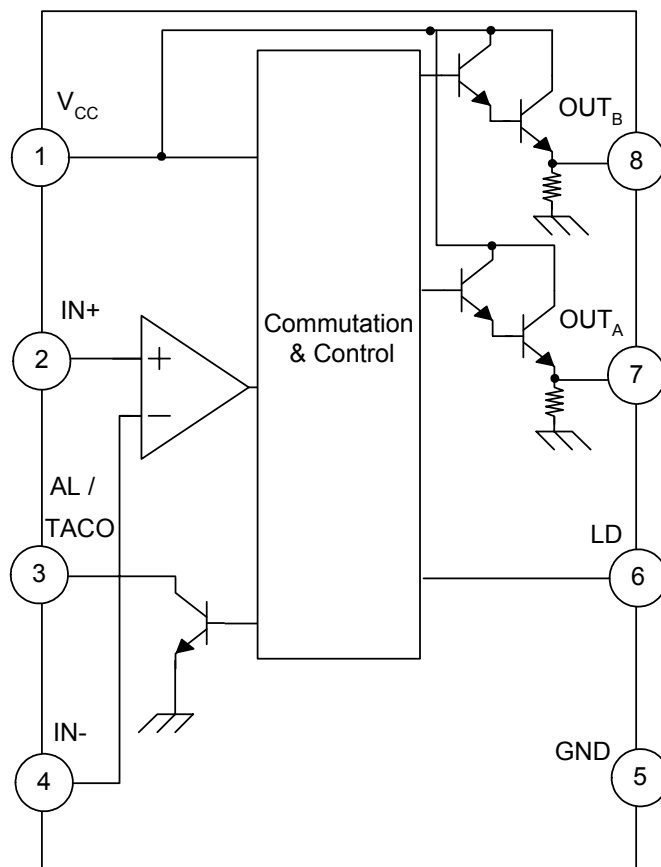

Pin Definitions

Pin Number	Pin Name	I/O	Pin Function Description	Remark
1	VCC	P	Supply voltage	-
2	IN+	A	Hall input +	-
3	AL	O	Alarm output (For FAN8412M)	Open Collector
	TACO	O	Speed output (For FAN8413M)	Open Collector
4	IN-	A	Hall input -	-
5	GND	P	Ground	-
6	LD	A	Triangle pulse generator for lock detector and automatic restart	-
7	OUTA	A	Motor output A	-
8	OUTB	A	Motor output B	-

Equivalent Circuits

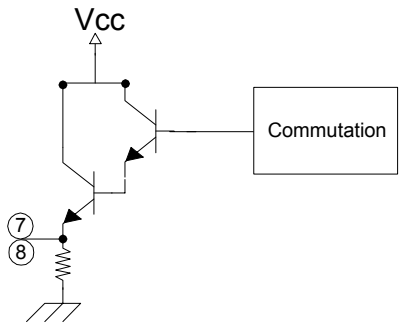
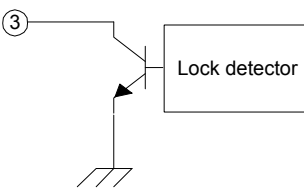
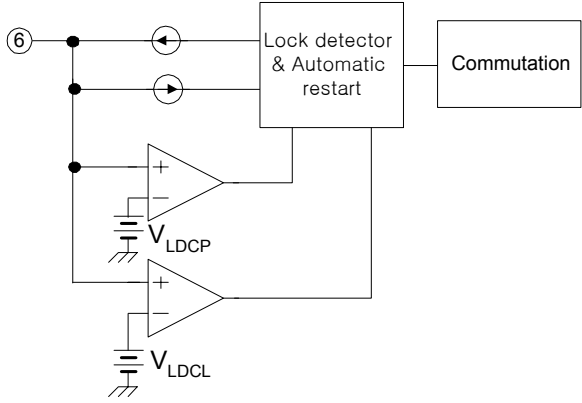
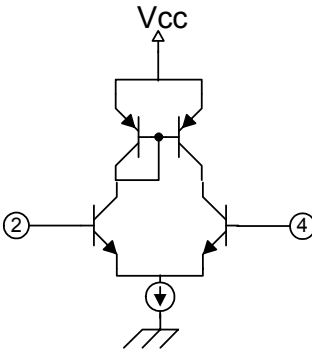
Description	Pin No.	Internal Circuit
OUT _A	7	
OUT _B	8	
AL / TACO	3	
LD	6	
IN ₊	2	
IN ₋	4	

Absolute Maximum Ratings (Ta = 25°C)

Parameter	Symbol	Value	Unit
Maximum Power Supply Voltage	VCCMAX	32	V
Maximum Power Dissipation ^{note1}	PDMAX	600	mW
Thermal Resistance ^{note1}	θJA	208	°C/W
Maximum Output Voltage	VOMAX	36	V
Maximum Output Current	IOMAX	0.07	A
Alarm Output Current	I _{AL}	10	mA
Alarm Output Withstanding Voltage	V _{AL}	36	V
TACO Output Current	I _{TACO}	10	mA
TACO Output Withstanding Voltage	V _{TACO}	36	V
Operating Temperature	T _{OPR}	-40 ~ 95	°C
Storage Temperature	T _{STG}	-55 ~ 150	°C

Note1:

PCB Condition: Thickness (1.6mm), Dimension (76.2mm * 114.3mm)

Refer: EIA/J SED 51-2 & EIA/J SED 51-3

Should not exceed PD or ASO value

Power Dissipation Curve (Air condition = 0m/s)

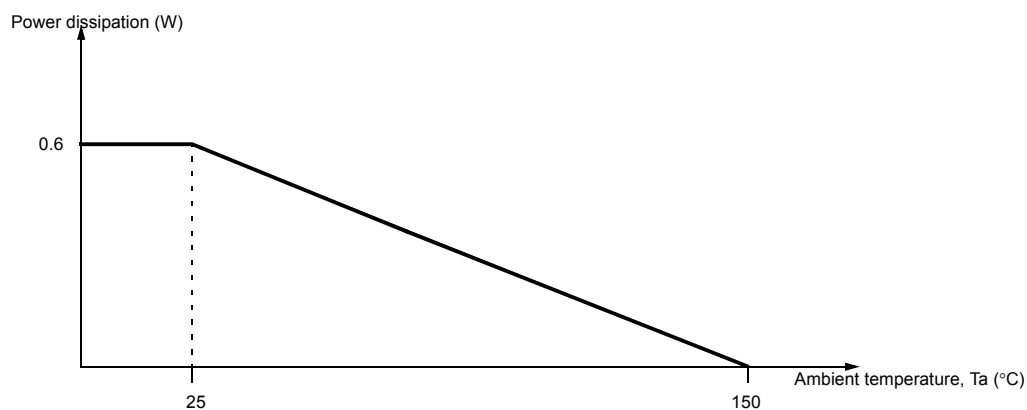

Recommended Operating Conditions (Ta = 25°C)

Parameter	Symbol	Min.	Typ.	Max.	Unit
Function Compensation Operating Voltage	VCC	4.0	–	28.0	V

Electrical Characteristics

(Ta=25°C, VCC=12V unless otherwise specified)

Parameter	Symbol	Conditions	Min.	Typ.	Max.	Unit
TOTAL						
Supply Current	ICC	When output is off.	-	3.2	5.0	mA
HALL AMPLIFIER INPUT RANGE						
Pin2,4 Hall Input Range	VHDC	-	1	-	Vcc-2	V
Pin2,4 Hall Input Offset	VHOF	-	15	-	-	mV
LOCK DETECTOR & AUTO RESTART						
Pin6 Lock Detector Charging Current	ILDC	VLD=1.5V	2.2	3.8	5.7	μA
Pin6 Lock Detector Discharging Current	ILDD	VLD=1.5V	0.4	0.88	1.6	μA
Pin6 Lock Detector Charging/Discharging Ratio	RCD	RCD=ILDC/ILDD	3	5	7	-
Pin6 Lock Detector Capacitor Clamp Voltage	VLDC	-	2.54	2.94	3.34	V
Pin6 Lock Detector Capacitor Comparator Voltage	VLDCP	-	0.54	0.74	0.94	V
OUTPUT STAGE						
Pin7, 8 Output High Level Voltage	VOH	IO=10mA	10	10.5	-	V
Pin7, 8 Output Low Level Voltage	VOL	IO=10mA	-	-	0.5	V
AL / TACO OUTPUT						
Pin3 Alarm Output Low Level Voltage	VALL	IO=10mA	-	0.2	0.5	V
Pin3 Alarm Output Current Capacity	I _{AL}	V _{AL} =2.0V	8	-	-	mA
Pin3 Taco Output Low Level Voltage	VTACOL	IO=10mA	-	0.2	0.5	V
Pin3 Taco Output Current Capacity	I _{TACOL}	V _{TACO} =2.0V	8	-	-	mA

Application Information

1. Lock Detection & Automatic Restart

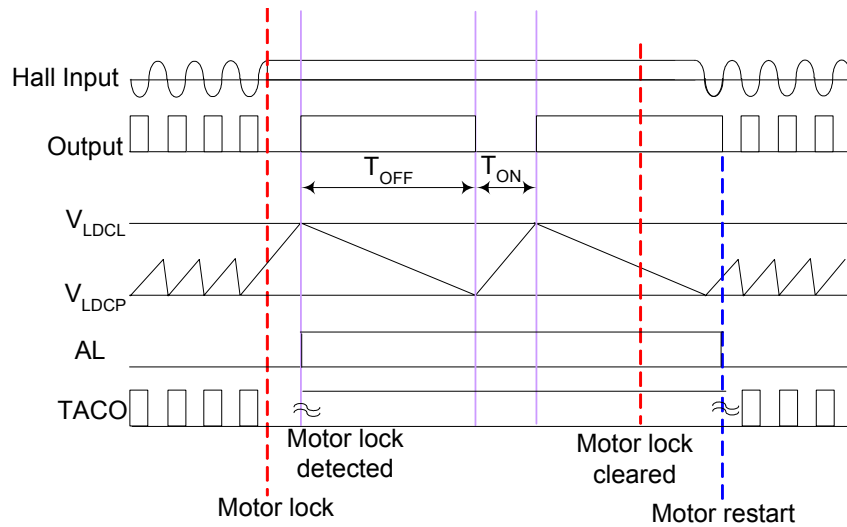

FAN8412M/FAN8413M features a lock detection and an automatic restart. The functions can be operated as follows.

When the rotor is locked, there is no change in input signal of hall amplifier.

A capacitor(C_{LD}) connected LD pin is continually charged by internal current source (I_{LDC}) to internal threshold(V_{LDCL}).

When the voltage, V_{CLD} on LD pin, reaches V_{LDCL} , output power TR is turned-off to protect motor during T_{OFF} and alarm output(AL) becomes floating high and taco output($TACO$) becomes remain high or low. When the V_{CLD} reaches upper threshold, V_{LDCL} , V_{CLD} starts to decrease with internal current sink (I_{LDD}) to the low threshold, V_{LDCLP} . At that time, the V_{CLD} charging repeat until locked condition is removed, or FAN8412M/FAN8413M is power down.

The auto-restart time (T_{ON}), the motor protection time(T_{OFF}) are proportional to external capacitor, C_{LD} and each value can be calculated as follow;

$$T_{ON} = \frac{C_{LD} \times (V_{LDCL} - V_{LDCLP})}{I_{LDC}}$$

$$T_{OFF} = \frac{C_{LD} \times (V_{LDCL} - V_{LDCLP})}{I_{LDD}}$$

For example, $C_{LD}=1\mu F$, then $T_{ON}=0.57\text{Sec}$, $T_{OFF}=2.2\text{Sec}$. This AL or $TACO$ output can be used to inform a locked rotor condition or speed information to super IO or system controller. Because the AL or $TACO$ output is open collector type, end user can pull up this pin with a external resistor to the supply voltage of their choice(that is 5 or 3.3V).

2. Hall Amplifier Input Block

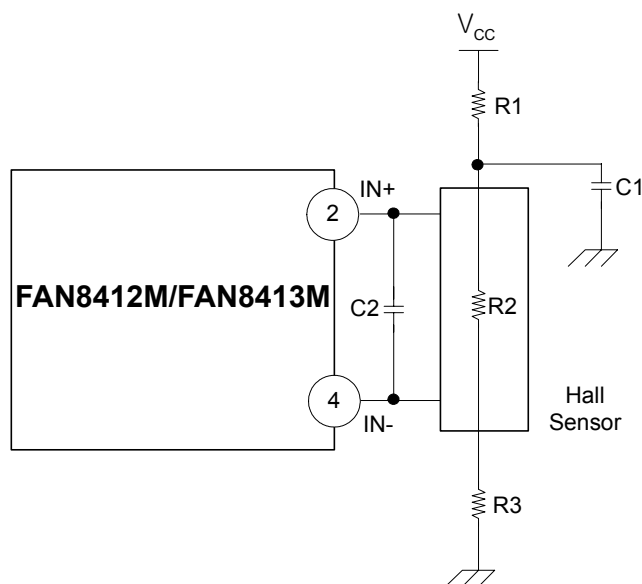

The hall current (I_H) is determined by R1, R2 and R3.

$$I_H = \frac{V_{CC}}{R1 + R2 + R3}$$

Where, the R2 is the impedance of hall sensor.

An external capacitor, C1, can be used to reduce a power supply noise. In addition, C2 is to remove a noise which is caused in case the line is long from the hall sensor output to the hall input (pin 2 / 4) of the device.

The input bias voltage of hall amplifier is between 1V and $V_{CC}-2V$ as following figure.

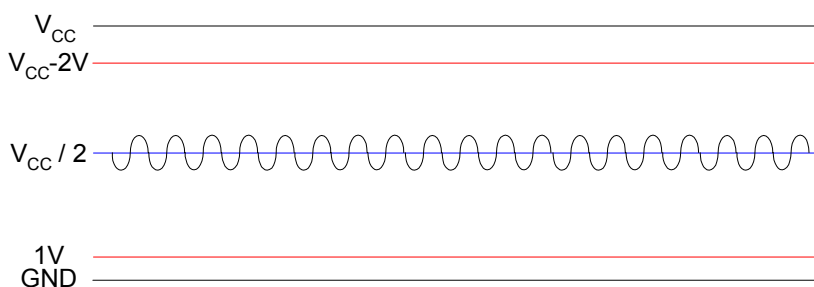

It is recommended that R1 and R3 should have the same value to make the output signal of hall sensor centered as $V_{CC}/2$.

Operation Truth Table

IN+	IN-	OUT _A	OUT _B	AL	TACO	Remark
High	Low	High	Low	Low	High	Rotating
Low	High	Low	High	Low	Low	
Low or High	Low or High	Low or High	Low or High	High	Low or High	Lock

Test Circuits

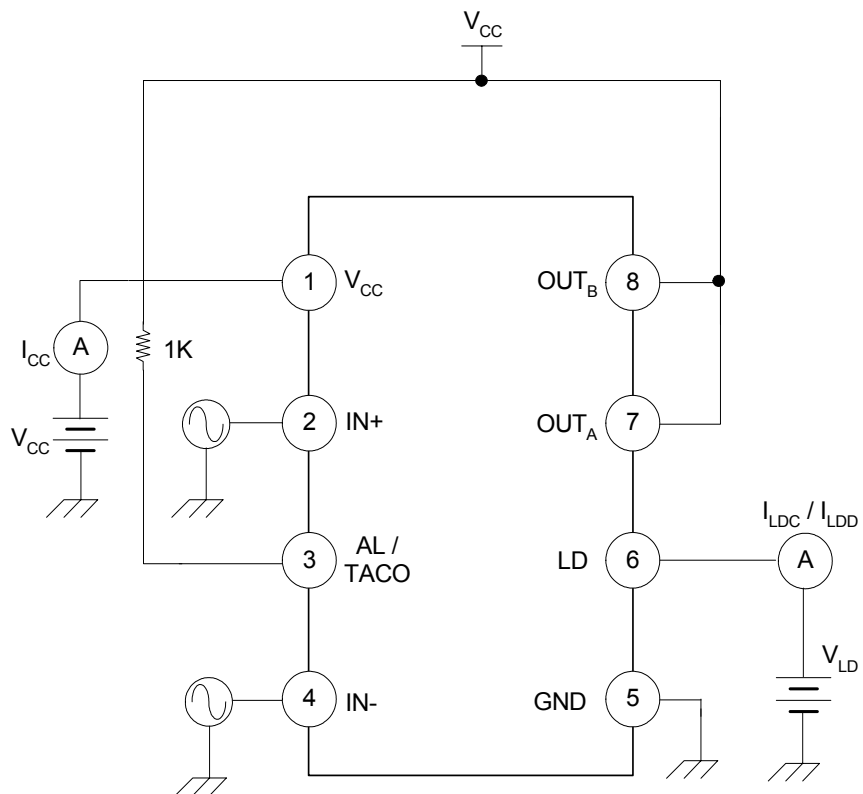

Typical Application Circuits1 (12V / 24V)

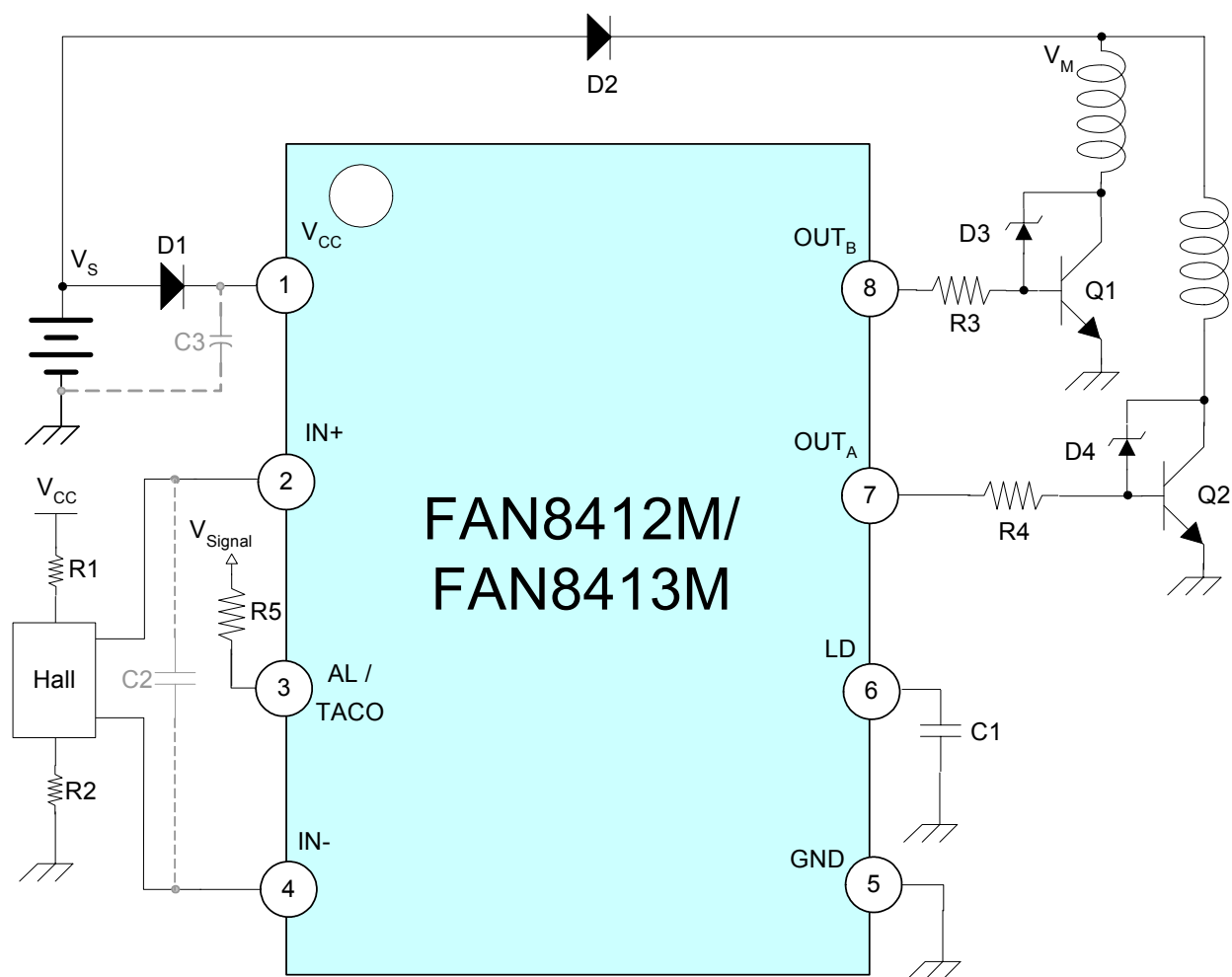

- 1.D1 : A reverse protection diode for IC.
 - 2.D2 : A reverse protection diode for motor coil.
 - 3.D3/D4 : Zener diode for freewheeling.
 - 4.R1/R2 : A resistor to set DC hall bias level.
 - 5.R3/R4 : A resistor to limit a base current of external power TR.
 6. R5 : A pull-up resistor for taco output signal when a fan motor is locked.
 7. C1 : A Capacitor for lock protection and detection of a fan motor.
- If lock protection and detection functions are not necessary , LD pin should be connect ground.
- 8.C2 : A capacitor to reduce a noise in hall input stage. This is not necessary in case of no noise.
 - 9.C3 : This is not necessary in case the stable input on VCC is provided.
 - 10.Q1/Q2 : An external power TR .

Typical Application Circuits2 (48V)

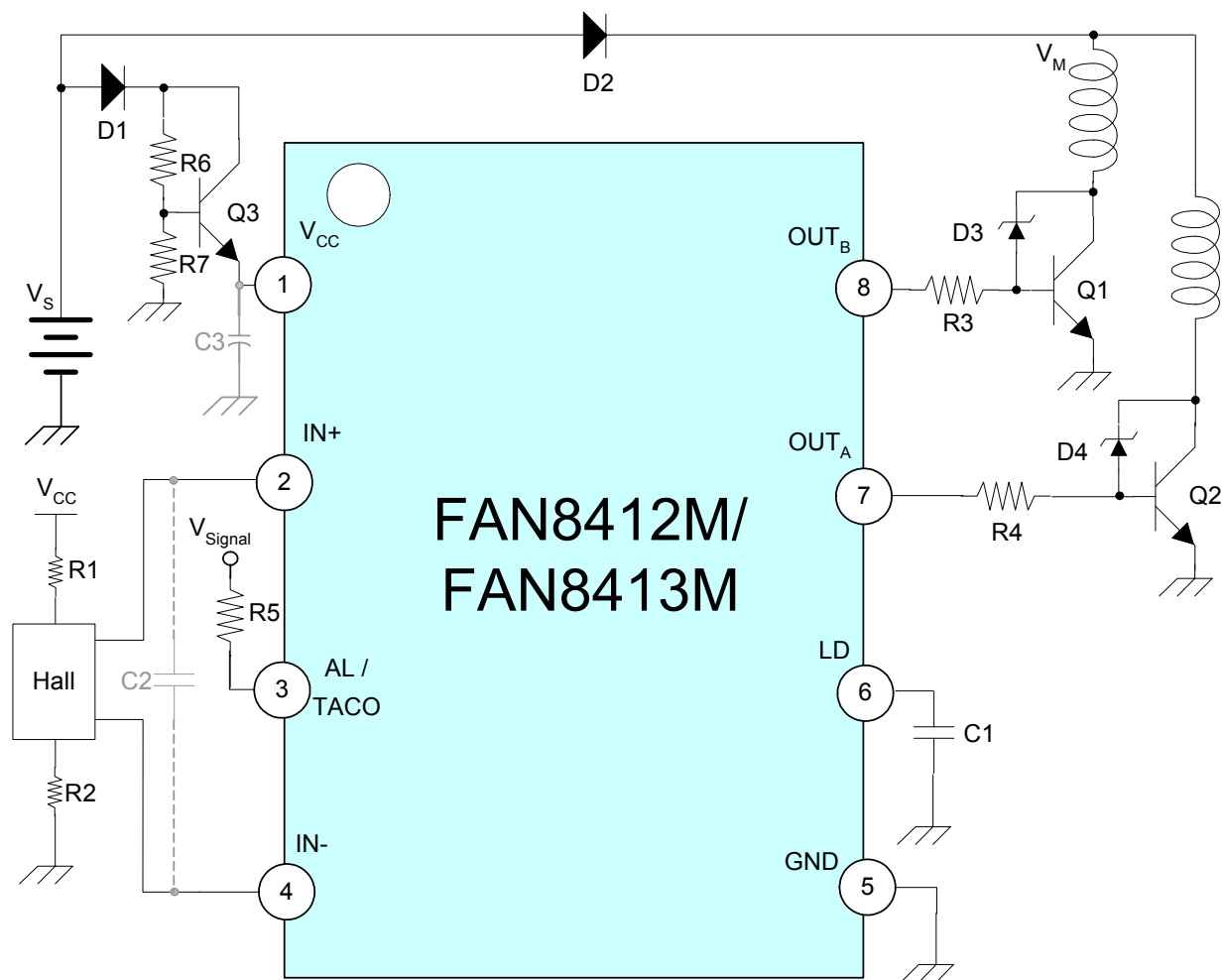

- 1.D1 : A reverse protection diode for IC.
 - 2.D2 : A reverse protection diode for motor coil.
 - 3.D3/D4 : Zener diode for freewheeling.
 - 4.R1/R2 : A resistor to set DC hall bias level.
 - 5.R3/R4 : A resistor to limit a base current of external power TR.
 - 6.R5 : A pull-up resistor for taco output signal when a fan motor is locked.
 - 7.R6/R7 : A resistor to set a output voltage of TR(Q3).
 - 8.C1 : A Capacitor for lock protection and detection of a fan motor.
- If lock protection and detection functions are not necessary , LD pin should be connect ground.
- 9.C2 : A capacitor to reduce a noise in hall input stage. This is not necessary in case of no noise.
 - 10.C3 : This is not necessary in case the stable input on V_{CC} is provided.
 - 11.Q1/Q2 : An external power TR .
 - 12.Q3 : An external power TR to control output voltage.

Package Dimensions (Unit: mm)

8-SOP-225

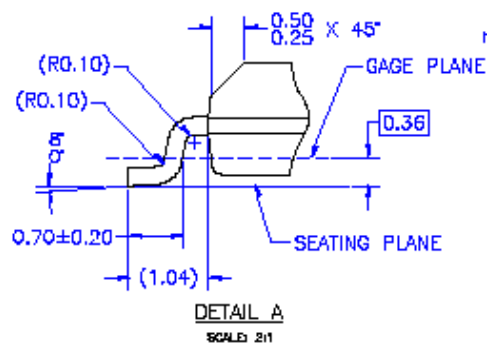
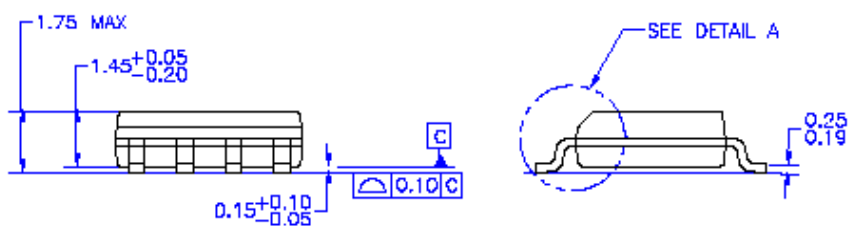
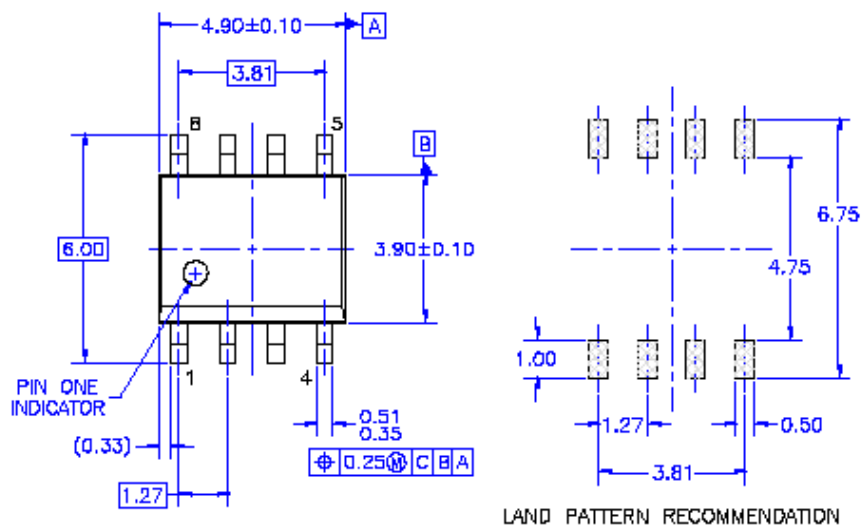

Package Dimensions (Unit: mm)

8-SOP Lead Free

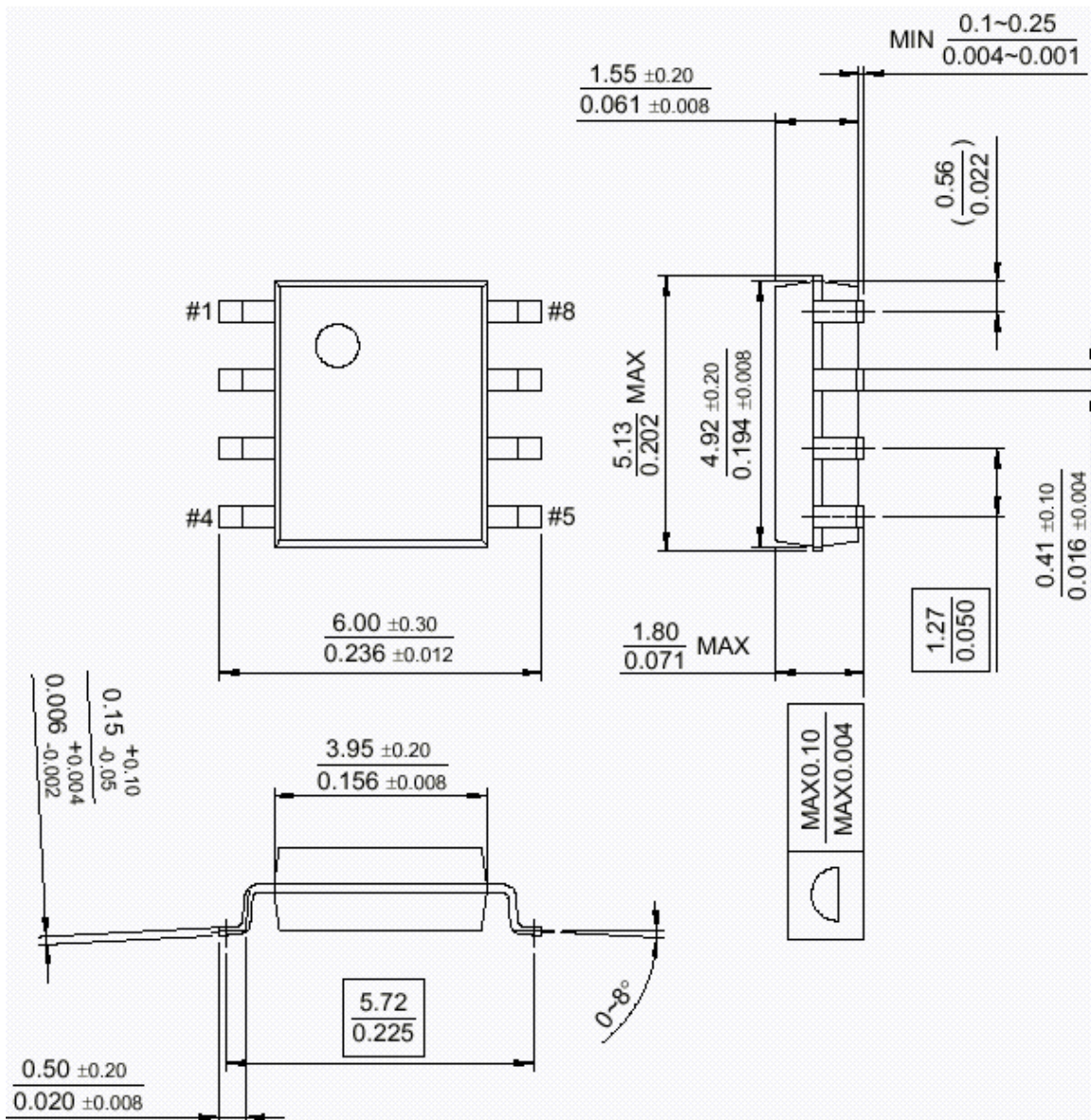

Typical Performance characteristics

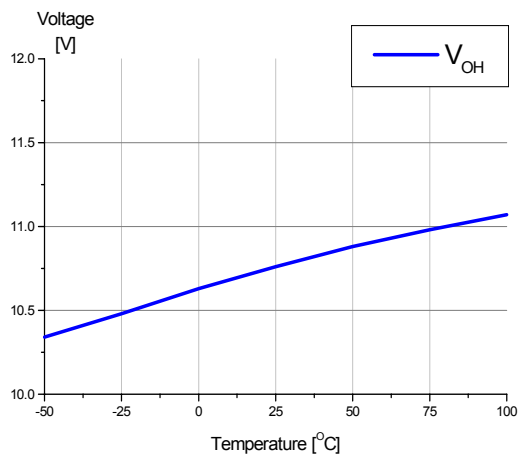
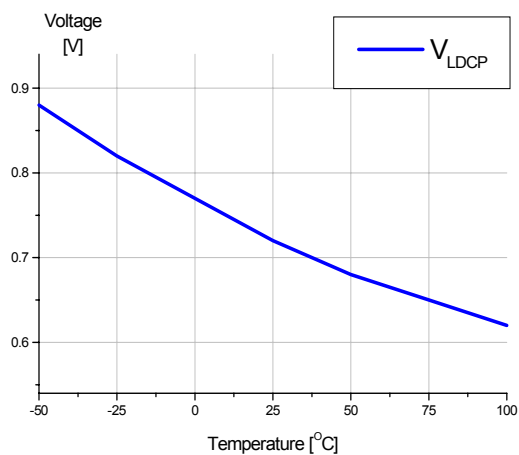
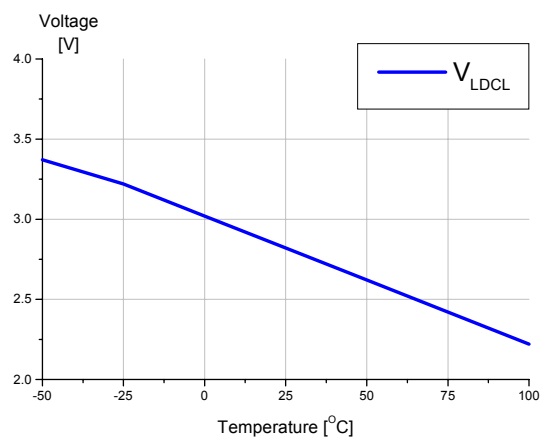
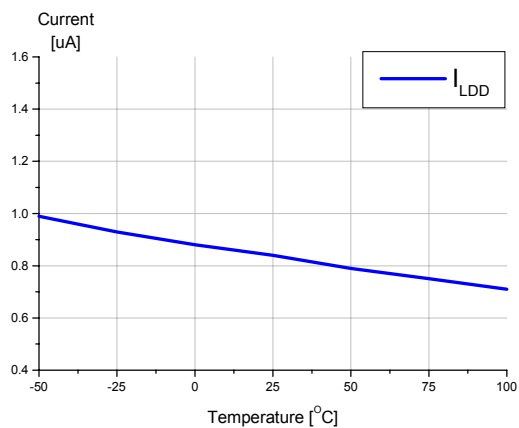
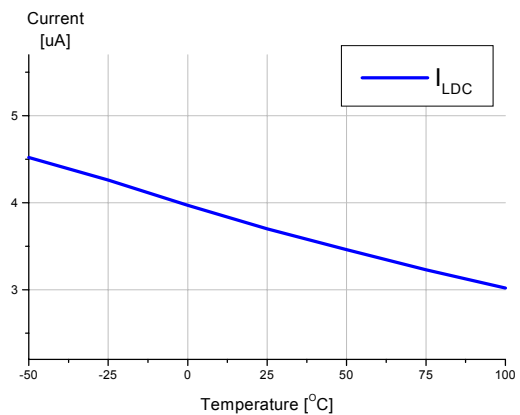
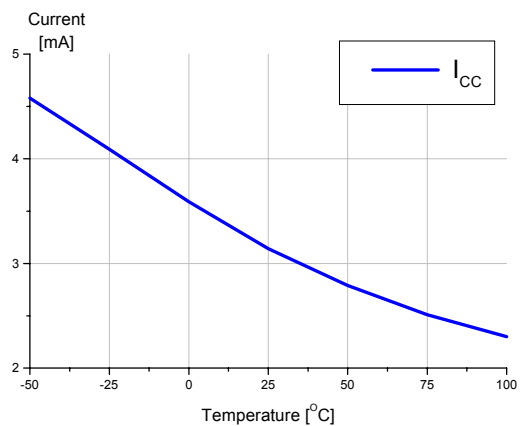

Typical Performance characteristics(Continued)

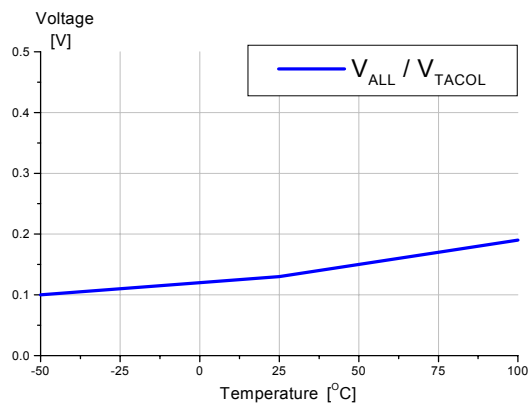

DISCLAIMER

FAIRCHILD SEMICONDUCTOR RESERVES THE RIGHT TO MAKE CHANGES WITHOUT FURTHER NOTICE TO ANY PRODUCTS HEREIN TO IMPROVE RELIABILITY, FUNCTION OR DESIGN. FAIRCHILD DOES NOT ASSUME ANY LIABILITY ARISING OUT OF THE APPLICATION OR USE OF ANY PRODUCT OR CIRCUIT DESCRIBED HEREIN; NEITHER DOES IT CONVEY ANY LICENSE UNDER ITS PATENT RIGHTS, NOR THE RIGHTS OF OTHERS.

LIFE SUPPORT POLICY

FAIRCHILD'S PRODUCTS ARE NOT AUTHORIZED FOR USE AS CRITICAL COMPONENTS IN LIFE SUPPORT DEVICES OR SYSTEMS WITHOUT THE EXPRESS WRITTEN APPROVAL OF THE PRESIDENT OF FAIRCHILD SEMICONDUCTOR CORPORATION. As used herein:

1. Life support devices or systems are devices or systems which, (a) are intended for surgical implant into the body, or (b) support or sustain life, and (c) whose failure to perform when properly used in accordance with instructions for use provided in the labeling, can be reasonably expected to result in a significant injury of the user.
2. A critical component in any component of a life support device or system whose failure to perform can be reasonably expected to cause the failure of the life support device or system, or to affect its safety or effectiveness.

ON Semiconductor and  are trademarks of Semiconductor Components Industries, LLC dba ON Semiconductor or its subsidiaries in the United States and/or other countries. ON Semiconductor owns the rights to a number of patents, trademarks, copyrights, trade secrets, and other intellectual property. A listing of ON Semiconductor's product/patent coverage may be accessed at www.onsemi.com/site/pdf/Patent-Marking.pdf. ON Semiconductor reserves the right to make changes without further notice to any products herein. ON Semiconductor makes no warranty, representation or guarantee regarding the suitability of its products for any particular purpose, nor does ON Semiconductor assume any liability arising out of the application or use of any product or circuit, and specifically disclaims any and all liability, including without limitation special, consequential or incidental damages. Buyer is responsible for its products and applications using ON Semiconductor products, including compliance with all laws, regulations and safety requirements or standards, regardless of any support or applications information provided by ON Semiconductor. "Typical" parameters which may be provided in ON Semiconductor data sheets and/or specifications can and do vary in different applications and actual performance may vary over time. All operating parameters, including "Typicals" must be validated for each customer application by customer's technical experts. ON Semiconductor does not convey any license under its patent rights nor the rights of others. ON Semiconductor products are not designed, intended, or authorized for use as a critical component in life support systems or any FDA Class 3 medical devices or medical devices with a same or similar classification in a foreign jurisdiction or any devices intended for implantation in the human body. Should Buyer purchase or use ON Semiconductor products for any such unintended or unauthorized application, Buyer shall indemnify and hold ON Semiconductor and its officers, employees, subsidiaries, affiliates, and distributors harmless against all claims, costs, damages, and expenses, and reasonable attorney fees arising out of, directly or indirectly, any claim of personal injury or death associated with such unintended or unauthorized use, even if such claim alleges that ON Semiconductor was negligent regarding the design or manufacture of the part. ON Semiconductor is an Equal Opportunity/Affirmative Action Employer. This literature is subject to all applicable copyright laws and is not for resale in any manner.

PUBLICATION ORDERING INFORMATION

LITERATURE FULFILLMENT:

Literature Distribution Center for ON Semiconductor
19521 E. 32nd Pkwy, Aurora, Colorado 80011 USA
Phone: 303-675-2175 or 800-344-3860 Toll Free USA/Canada
Fax: 303-675-2176 or 800-344-3867 Toll Free USA/Canada
Email: orderlit@onsemi.com

N. American Technical Support: 800-282-9855 Toll Free
USA/Canada
Europe, Middle East and Africa Technical Support:
Phone: 421 33 790 2910
Japan Customer Focus Center
Phone: 81-3-5817-1050

ON Semiconductor Website: www.onsemi.com
Order Literature: <http://www.onsemi.com/orderlit>
For additional information, please contact your local
Sales Representative