12 V – 150 W power supply based on STNRG011 digital combo and SRK2001 adaptive synchronous rectifier controller

Data brief

**Features**

- Digital controller: STNRG011
- TM PFC with resonant HB-LLC converter
- Input voltage range: 90 ÷ 264 V ac
- 12 V ± 5% CV output regulation
- Full-load power: 150 W continuous operation
- Peak power loading: 200 W
- Full-load and average efficiency: greater than 90% at 115/230 V ac
- Peak efficiency: greater than 93%
- No-load mains consumption: less than 75 mW
- Hold-up time: greater than 10 ms
- Full set of programmable parameters
- High flexibility thanks to the configurable NVM
- Black box functionality with the installed EEPROM

Description

The EVLSTNRG011-150 is a 12 V, 150 W power supply demonstration board for 90 V ac to 264 V ac mains, which is representative of an AC/DC converter for an all in one (AIO) computer or a general purpose high power adapter.

The design is based on the STNRG011 IC, a digital combo that controls a two-stage AC/DC SMPL. The front-end is a transition mode PFC pre-regulator and the second stage is an LLC HB resonant converter. The SRK2001 implements the synchronous rectification in order to obtain higher efficiency.

No auxiliary supply is needed due to the very low consumption at no load.

A full set of auxiliary functions and protection is also provided, this allows reduction of the overall BOM while maintaining a rugged design.

The performances of the EVLSTNRG011-150 can meet the requirements of major standards ENERGY STAR® for computers ver. 6.1, EuP Lot 6 Tier 2, European CoC ver. 5 Tier-2, in terms of efficiency, no-load input power and power factor and feature harmonics content well below the limits of European Standard EN61000-3-2 Class-D and Japanese standard JEITA-MITI Class-D regulations.

Figure 2. Feedback (control) board electrical diagram

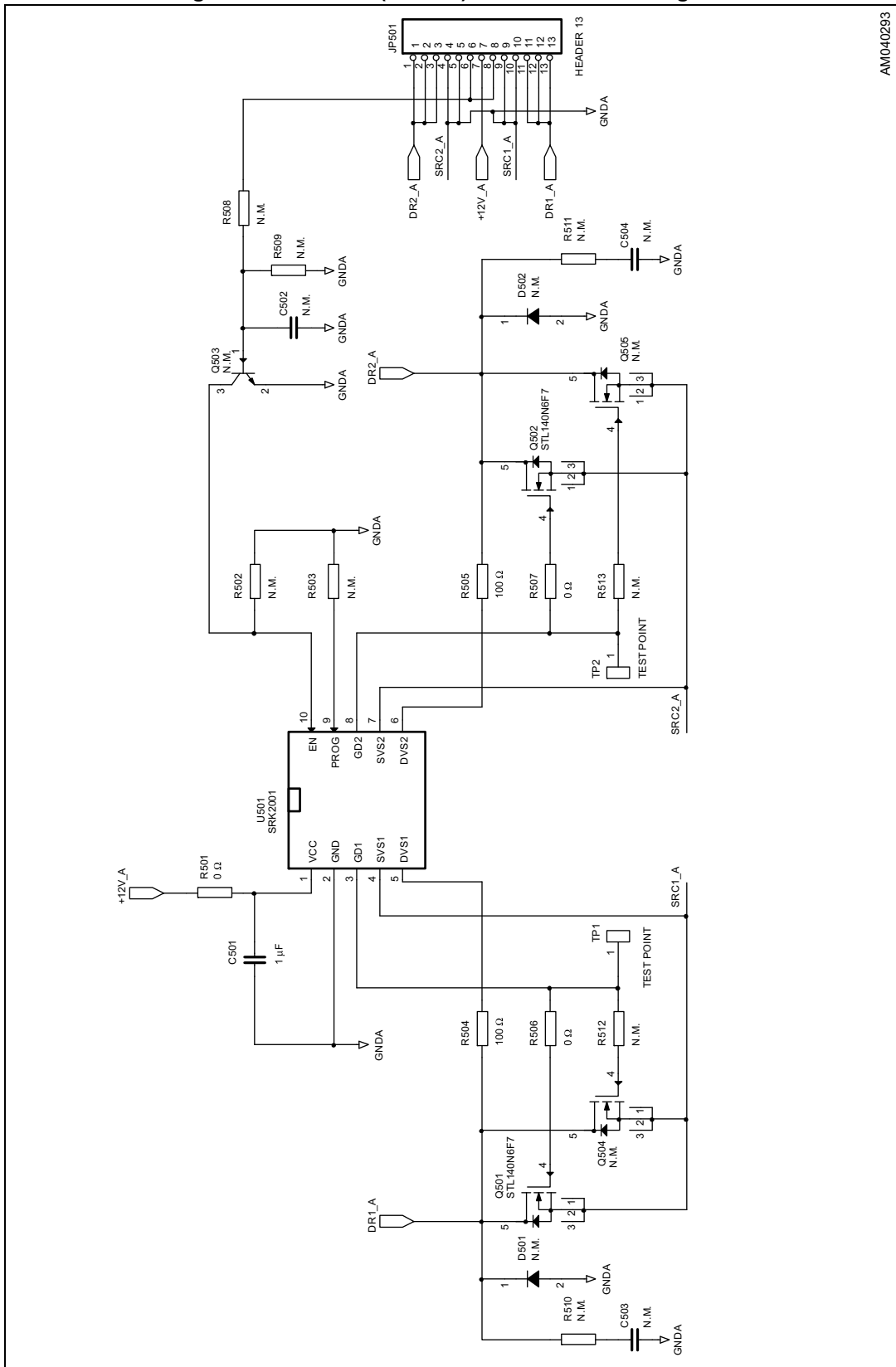

AM040293



Figure 3. Synchronous rectification (SRK) board electrical diagram

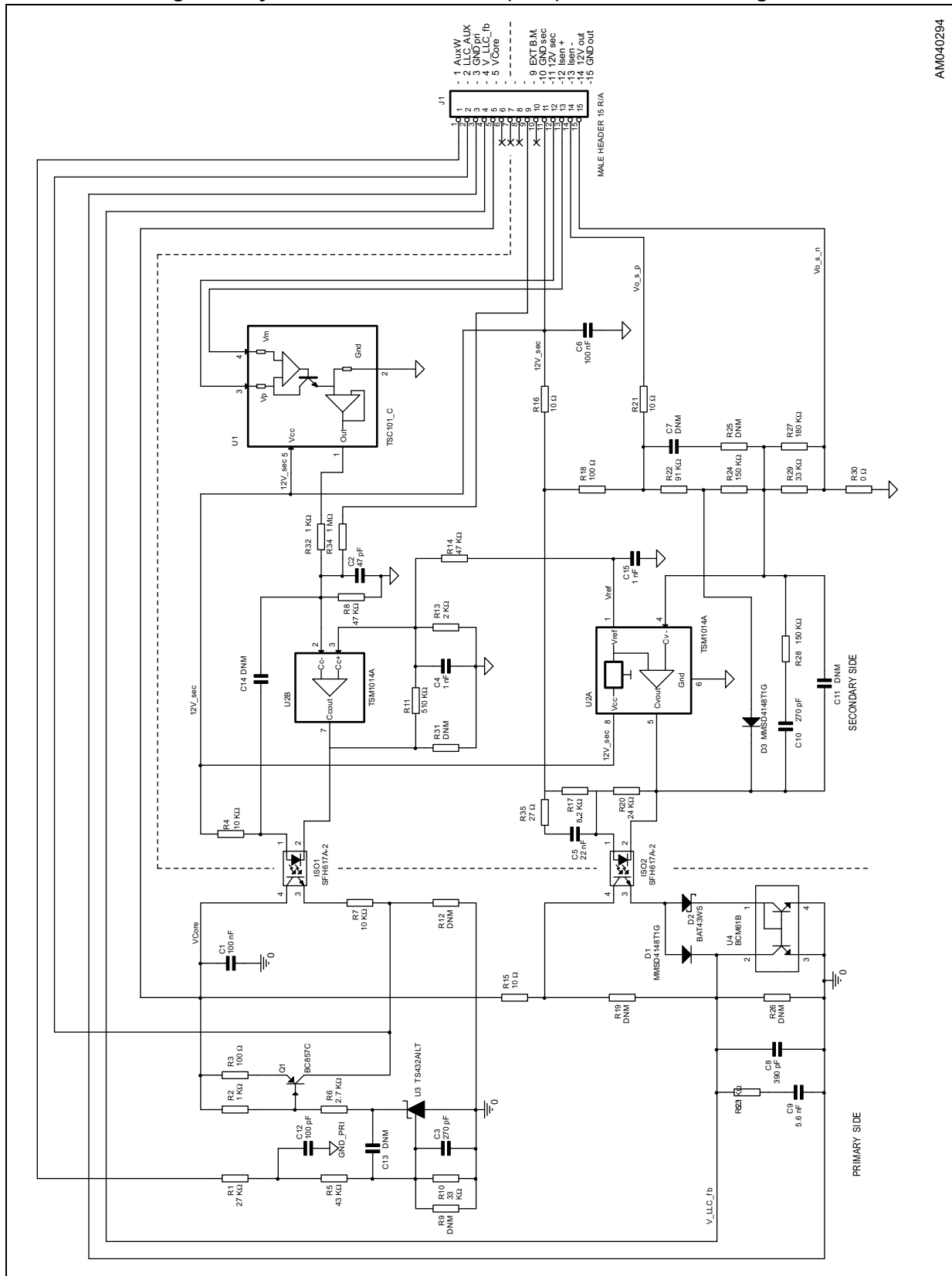

AM040294



Revision history

Table 1. Document revision history

Date	Revision	Changes
14-Feb-2018	1	Initial release.

IMPORTANT NOTICE – PLEASE READ CAREFULLY

STMicroelectronics NV and its subsidiaries ("ST") reserve the right to make changes, corrections, enhancements, modifications, and improvements to ST products and/or to this document at any time without notice. Purchasers should obtain the latest relevant information on ST products before placing orders. ST products are sold pursuant to ST's terms and conditions of sale in place at the time of order acknowledgement.

Purchasers are solely responsible for the choice, selection, and use of ST products and ST assumes no liability for application assistance or the design of Purchasers' products.

No license, express or implied, to any intellectual property right is granted by ST herein.

Resale of ST products with provisions different from the information set forth herein shall void any warranty granted by ST for such product.

ST and the ST logo are trademarks of ST. All other product or service names are the property of their respective owners.

Information in this document supersedes and replaces information previously supplied in any prior versions of this document.

© 2018 STMicroelectronics – All rights reserved