

IIS328DQ adapter board for a standard DIL 24 socket

Data brief

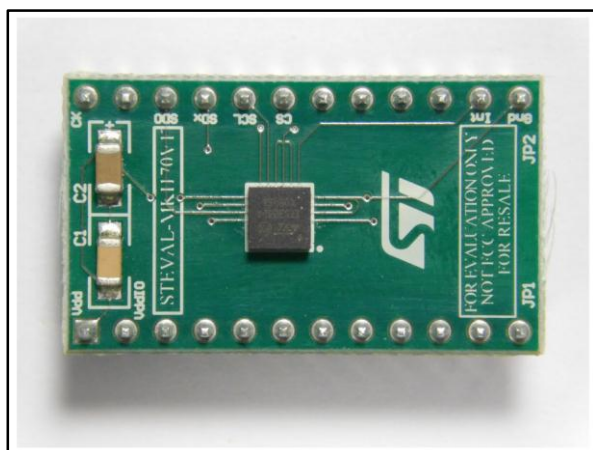

Features

- Complete IIS328DQ pinout for a standard DIL 24 socket
- Fully compatible with the STEVAL-MKI109V2 motherboard
- RoHS compliant

Description

The STEVAL-MKI170V1 adapter board is designed to facilitate the evaluation of MEMS devices in the IIS328DQ product family. The board offers an effective solution for fast system prototyping and device evaluation directly inside the user's application.

The STEVAL-MKI170V1 can be plugged into a standard DIL 24 socket. The adapter provides the complete IIS328DQ pin-out and comes ready-to-use with the required decoupling capacitors on the V_{DD} power supply line.

This adapter is supported by the STEVAL-MKI109V2 motherboard, which includes a high performance 32-bit microcontroller functioning as a bridge between the sensor and a PC, on which it is possible to use the downloadable graphical user interface (Unico GUI), or dedicated software routines for customized applications.

1 Schematic diagram

Figure 1: STEVAL-MKI170V1 circuit schematic

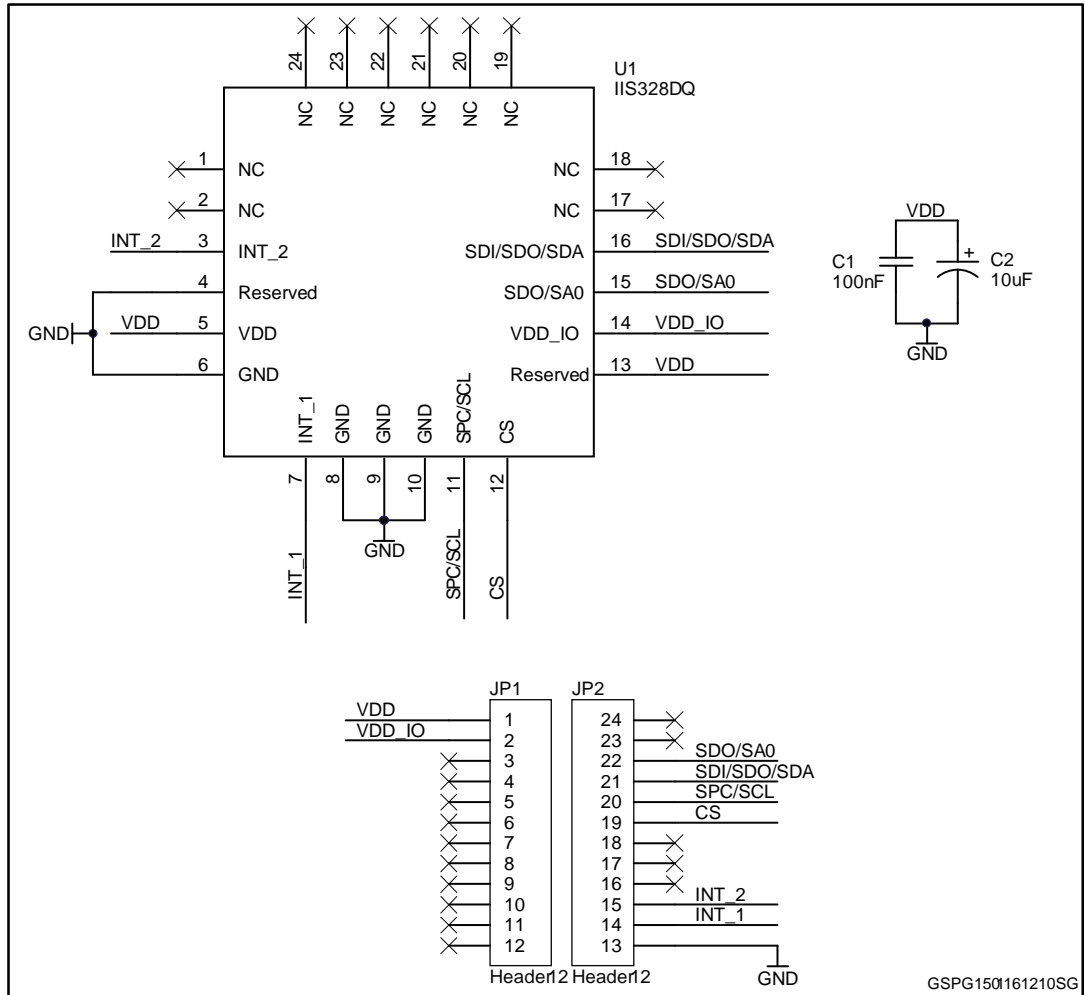

2 Revision history

Table 1: Document revision history

Date	Version	Changes
21-Jan-2016	1	Initial release.

IMPORTANT NOTICE – PLEASE READ CAREFULLY

STMicroelectronics NV and its subsidiaries ("ST") reserve the right to make changes, corrections, enhancements, modifications, and improvements to ST products and/or to this document at any time without notice. Purchasers should obtain the latest relevant information on ST products before placing orders. ST products are sold pursuant to ST's terms and conditions of sale in place at the time of order acknowledgement.

Purchasers are solely responsible for the choice, selection, and use of ST products and ST assumes no liability for application assistance or the design of Purchasers' products.

No license, express or implied, to any intellectual property right is granted by ST herein.

Resale of ST products with provisions different from the information set forth herein shall void any warranty granted by ST for such product.

ST and the ST logo are trademarks of ST. All other product or service names are the property of their respective owners.

Information in this document supersedes and replaces information previously supplied in any prior versions of this document.

© 2016 STMicroelectronics – All rights reserved