

P3P8220A/AH

General Purpose Peak EMI Reduction IC

Functional Description

P3P8220A/AH is a versatile, 1.8V/2.5V/3.3V Peak EMI reduction IC. P3P8220A accepts an input clock from an external reference and delivers a 1x modulated clock output.

P3P8220A is a Low drive part and P3P8220AH is a High drive part. Refer to *DC/AC Electrical characteristic* table.

P3P8220A/AH operates with 1.8V/2.5V/3.3V supply and is available in an 8 Pin, WDFN (2 mm x 2 mm) Package.

General Features

- 1x, LVCMOS Peak EMI Reduction
- Supports Non-continuous Input Clock Applications
- Input / Output Frequency Range: Up to 60 MHz
- Low and High Drive Part
- Supply Voltage: 1.8 V \pm 0.1 V
2.5 V \pm 0.2 V
3.3 V \pm 0.3 V
- 8-Pin, WDFN(2 mm x 2 mm) Package
- These Devices are Pb-Free, Halogen Free/BFR Free and are RoHS Compliant

Application

- P3P8220A is Targeted Towards Consumer Electronic Applications

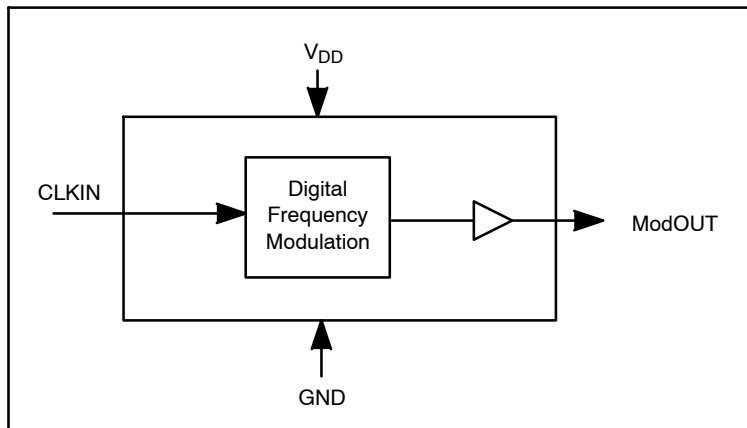

Figure 1. Block Diagram



ON Semiconductor®

<http://onsemi.com>

MARKING DIAGRAM

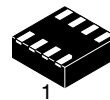

WDFN8
CASE 511AQ



GH = Specific Device Code
M = Date Code
▪ = Pb-Free Device

PIN CONFIGURATION

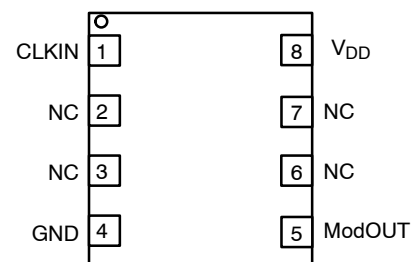

ORDERING INFORMATION

See detailed ordering and shipping information in the package dimensions section on page 6 of this data sheet.

P3P8220A/AH

Table 1. PIN DESCRIPTION

Pin #	Pin Name	Type	Description
1	CLKIN	I	External reference Clock Input
2	NC		No connection
3	NC		No connection
4	GND	P	Ground
5	ModOUT	O	Buffered Modulated Clock output.
6	NC		No connection
7	NC		No connection
8	V _{DD}	P	1.8V/2.5V/3.3V Supply Voltage

Table 2. OPERATING CONDITIONS

Symbol	Description	Min	Max	Unit
V _{DD}	Supply Voltage	1.8 V 2.5 V 3.3 V	1.7 2.7 3.6	V
T _A	Operating Temperature (Ambient Temperature)	0	70	°C
C _L	Load Capacitance		15	pF
C _{IN}	Input Capacitance		7	pF

Table 3. ABSOLUTE MAXIMUM RATING

Symbol	Description	Rating	Unit
V _{DD} , V _{IN}	Voltage on any input pin with respect to Ground	-0.5 to +4.6	V
T _{STG}	Storage temperature	-65 to +125	°C
T _s	Max. Soldering Temperature (10 sec)	260	°C
T _J	Junction Temperature	150	°C
T _{DV}	Static Discharge Voltage (As per JEDEC STD22- A114-B)	2	KV

Stresses exceeding Maximum Ratings may damage the device. Maximum Ratings are stress ratings only. Functional operation above the Recommended Operating Conditions is not implied. Extended exposure to stresses above the Recommended Operating Conditions may affect device reliability.

NOTE: These are stress ratings only and are not implied for functional use. Exposure to absolute maximum ratings for prolonged periods of time may affect device reliability.

P3P8220A/AH

Table 4. ELECTRICAL CHARACTERISTICS

Symbol	Parameter	Test Conditions		Min	Typ	Max	Unit
$V_{DD(1.8V)}$	Supply Voltage			1.7	1.8	1.9	V
$V_{DD(2.5V)}$				2.3	2.5	2.7	
$V_{DD(3.3V)}$				3	3.3	3.6	
V_{IL}	Input LOW Voltage					$0.35 \cdot V_{DD}$	V
V_{IH}	Input HIGH Voltage			$0.65 \cdot V_{DD}$		$V_{DD} + 0.3$	V
V_{OL}	Output LOW Voltage	P3P8220A	$V_{DD(1.8V)}$, $I_{OL} = 4mA$			$0.25 \cdot V_{DD}$	V
			$V_{DD(2.5V, 3.3V)}$, $I_{OL} = 8mA$				
		P3P8220AH	$V_{DD(1.8V)}$, $I_{OL} = 6mA$				
			$V_{DD(2.5V, 3.3V)}$, $I_{OL} = 12mA$				
V_{OH}	Output HIGH Voltage	P3P8220A	$V_{DD(1.8V)}$, $I_{OL} = -4mA$	$0.75 \cdot V_{DD}$			V
			$V_{DD(2.5V, 3.3V)}$, $I_{OL} = -8mA$				
		P3P8220AH	$V_{DD(1.8V)}$, $I_{OL} = -6mA$				
			$V_{DD(2.5V, 3.3V)}$, $I_{OL} = -12mA$				
I_{CC}	Static Supply Current	CLKIN pulled LOW	$V_{DD(1.8V)}$			1.3	mA
			$V_{DD(2.5V)}$			1.5	
			$V_{DD(3.3V)}$			1.7	
I_{DD}	Dynamic Supply Current	$V_{DD(1.8V)}$	15 MHz			2.3	mA
			60 MHz			6.0	
		$V_{DD(2.5V)}$	15 MHz			3.2	
			60 MHz			8.0	
		$V_{DD(3.3V)}$	15 MHz			4.5	
			60 MHz			12	
C_L	Load Capacitance					15	pF
Z_0	Output Impedance	$V_{DD(1.8V)}$	P3P8220A		50		Ω
			P3P8220AH		30		
		$V_{DD(2.5V)}$	P3P8220A		36		
			P3P8220AH		24		
		$V_{DD(3.3V)}$	P3P8220A		30		
			P3P8220AH		20		

P3P8220A/AH

Table 5. SWITCHING CHARACTERISTICS

Parameter	Test Conditions		Min	Typ	Max	Unit	
Input Frequency					60	MHz	
ModOUT					60		
Output Rise Time (Notes 1 & 2)	Measured between 20% to 80%	V _{DD} (1.8V)	P3P8220A		3.0	5.0	ns
			P3P8220AH		2.0	4.0	
		V _{DD} (2.5V)	P3P8220A		1.8	3.0	
			P3P8220AH		1.2	2.5	
		V _{DD} (3.3V)	P3P8220A		1.4	2.5	
			P3P8220AH		1.0	1.6	
Output Fall Time (Notes 1 & 2)	Measured between 20% to 80%	V _{DD} (1.8V)	P3P8220A		2.4	4.0	
			P3P8220AH		1.6	3.0	
		V _{DD} (2.5V)	P3P8220A		1.8	3.0	
			P3P8220AH		1.2	2.0	
		V _{DD} (3.3V)	P3P8220A		1.4	2.0	
			P3P8220AH		1.0	1.6	
Output Duty Cycle (Notes 1, 2 & 3)	Measured at VDD/2		45	50	55	%	
Cycle-to-Cycle Jitter (Note 1)	Unloaded spreaded output	V _{DD} (1.8V)	15 MHz		±350		ps
			60 MHz		±200		
		V _{DD} (2.5V)	15 MHz		±500		
			60 MHz		±150		
		V _{DD} (3.3V)	15 MHz		±750		
			60 MHz		±200		
Maximum Input-Output Delay (Notes 1 & 2)	Unloaded spreaded output	V _{DD} (1.8V)			7.5	ns	
		V _{DD} (2.5V)			7.5		
		V _{DD} (3.3V)			7.5		

1. Parameter is guaranteed by design and characterization. Not 100% tested in production.
2. All parameters are specified with 15 pF loaded outputs.
3. For an input Duty Cycle (typ) of 50%.

P3P8220A/AH

SWITCHING WAVEFORMS

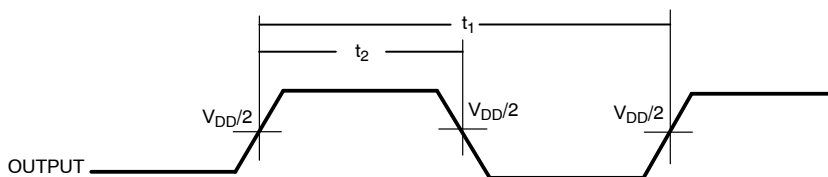

Figure 2. Duty Cycle Timing

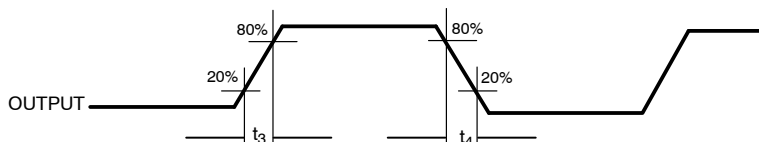

Figure 3. Output Rise/Fall Time

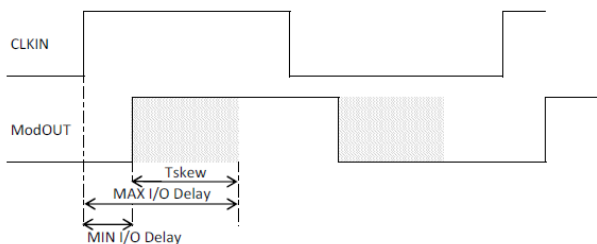
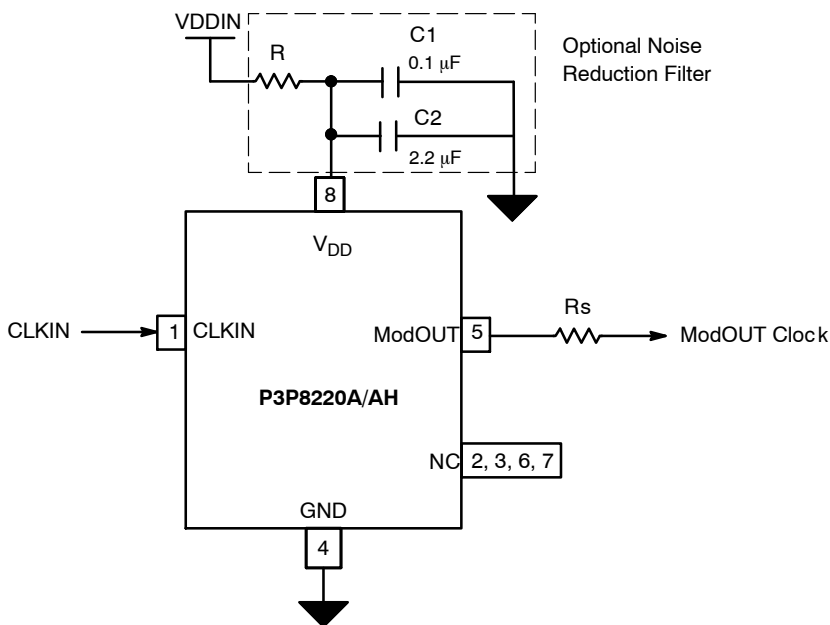

Figure 4. Input - Output Propagation Delay



NOTE: Refer Pin Description table for Functionality details.

Figure 5. Typical Application Circuit

NOTE: Device to Device variation of T_{skew} and I/O delay is $\pm 20\%$.

P3P8220A/AH

ORDERING INFORMATION

Ordering Code	Marking	Temperature	Package Type	Shipping [†]
P3P8220AG-08CR	GH	0°C to +70°C	8-pin (2 mm x 2 mm) WDFN (Pb-Free)	Tape & Reel

[†]For information on tape and reel specifications, including part orientation and tape sizes, please refer to our Tape and Reel Packaging Specifications Brochure, BRD8011/D.

*A "microdot" placed at the end of last row of marking or just below the last row toward the center of package indicates Pb-Free.

P3P8220A/AH

PACKAGE DIMENSIONS

WDFN8 2x2, 0.5P
CASE 511AQ-01
ISSUE A

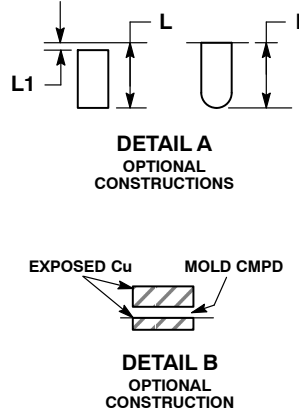
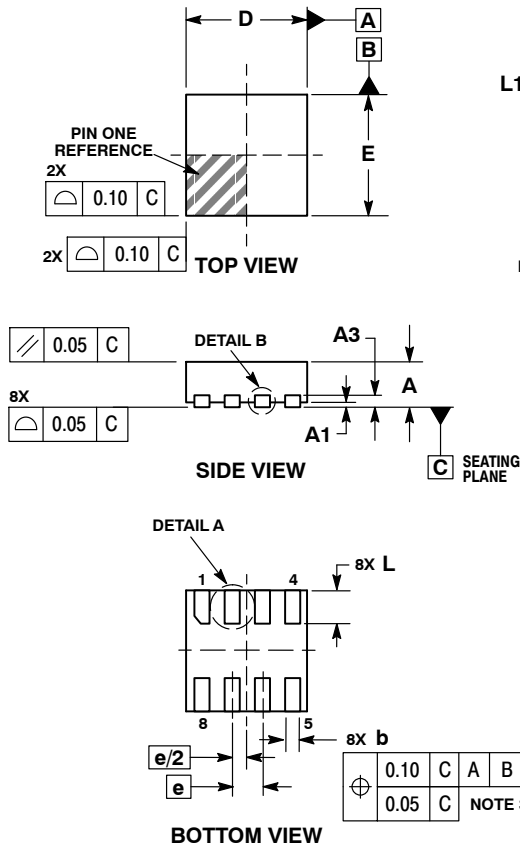

- NOTES:
1. DIMENSIONING AND TOLERANCING PER ASME Y14.5M, 1994.
 2. CONTROLLING DIMENSION: MILLIMETERS.
 3. DIMENSION b APPLIES TO PLATED TERMINAL AND IS MEASURED BETWEEN 0.15 AND 0.30mm FROM TERMINAL.

DIM	MILLIMETERS	
	MIN	MAX
A	0.70	0.80
A1	0.00	0.05
A3	0.20	REF
b	0.20	0.30
D	2.00	BSC
E	2.00	BSC
e	0.50	BSC
L	0.50	0.60
L1	---	0.15

RECOMMENDED SOLDERING FOOTPRINT*

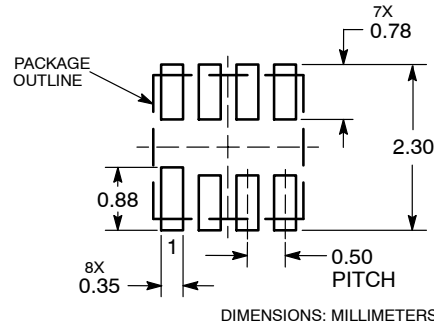

*For additional information on our Pb-Free strategy and soldering details, please download the ON Semiconductor Soldering and Mounting Techniques Reference Manual, SOLDERRM/D.

ON Semiconductor and are registered trademarks of Semiconductor Components Industries, LLC (SCILLC). SCILLC reserves the right to make changes without further notice to any products herein. SCILLC makes no warranty, representation or guarantee regarding the suitability of its products for any particular purpose, nor does SCILLC assume any liability arising out of the application or use of any product or circuit, and specifically disclaims any and all liability, including without limitation special, consequential or incidental damages. "Typical" parameters which may be provided in SCILLC data sheets and/or specifications can and do vary in different applications and actual performance may vary over time. All operating parameters, including "Typicals" must be validated for each customer application by customer's technical experts. SCILLC does not convey any license under its patent rights nor the rights of others. SCILLC products are not designed, intended, or authorized for use as components in systems intended for surgical implant into the body, or other applications intended to support or sustain life, or for any other application in which the failure of the SCILLC product could create a situation where personal injury or death may occur. Should Buyer purchase or use SCILLC products for any such unintended or unauthorized application, Buyer shall indemnify and hold SCILLC and its officers, employees, subsidiaries, affiliates, and distributors harmless against all claims, costs, damages, and expenses, and reasonable attorney fees arising out of, directly or indirectly, any claim of personal injury or death associated with such unintended or unauthorized use, even if such claim alleges that SCILLC was negligent regarding the design or manufacture of the part. SCILLC is an Equal Opportunity/Affirmative Action Employer. This literature is subject to all applicable copyright laws and is not for resale in any manner.

PUBLICATION ORDERING INFORMATION

LITERATURE FULFILLMENT:
Literature Distribution Center for ON Semiconductor
P.O. Box 5163, Denver, Colorado 80217 USA
Phone: 303-675-2175 or 800-344-3860 Toll Free USA/Canada
Fax: 303-675-2176 or 800-344-3867 Toll Free USA/Canada
Email: orderlit@onsemi.com

N. American Technical Support: 800-282-9855 Toll Free
USA/Canada
Europe, Middle East and Africa Technical Support:
Phone: 421 33 790 2910
Japan Customer Focus Center
Phone: 81-3-5773-3850

ON Semiconductor Website: www.onsemi.com
Order Literature: <http://www.onsemi.com/orderlit>
For additional information, please contact your local Sales Representative

P3P8220A/D