

NLAS4783B

Triple SPDT 1.0 Ω R_{ON} Switch

The NLAS4783B is a triple independent low R_{ON} SPDT analog switch with ENABLE. This device is designed for low operating voltage, high current switching of speaker output for cell phone applications. It can switch a balanced stereo output. The NLAS4783B can handle a balanced microphone/speaker/ring-tone generator in a monophone mode. The device contains a break-before-make feature.

Features

- Single Supply Operation
1.65 to 4.5 V V_{CC}
Function Directly from LiON Battery
- Tiny 3 x 3 mm 16-Pin QFN Package
Meets JEDEC MO-220 Specifications
- Low Static Power
- OVT on Logic Address and Enable Inputs
- This is a Pb-Free Device*

Typical Applications

- Cell Phone Speaker/Microphone Switching
- Ringtone-Chip/Amplifier Switching
- Three Unbalanced (Single-Ended) Switches
- Stereo Balanced (Push-Pull) Switching

Important Information

- ESD Protection:
Human Body Model (HBM) > 8000 V
Machine Model (MM) > 400 V
- Ringtone-Chip/Amplifier Switching
- Continuous Current Rating Through each Switch ± 300 mA
- Conforms to: JEDEC MO-220, Issue H, Variation VEED-6
- Pin-for-Pin Compatible with MAX4783



ON Semiconductor®

<http://onsemi.com>

MARKING DIAGRAM

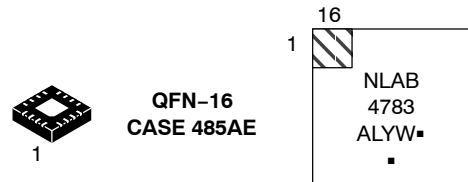

A = Assembly Location
L = Wafer Lot
Y = Year
W = Work Week
▪ = Pb-Free Package
(Note: Microdot may be in either location)

PIN CONNECTIONS

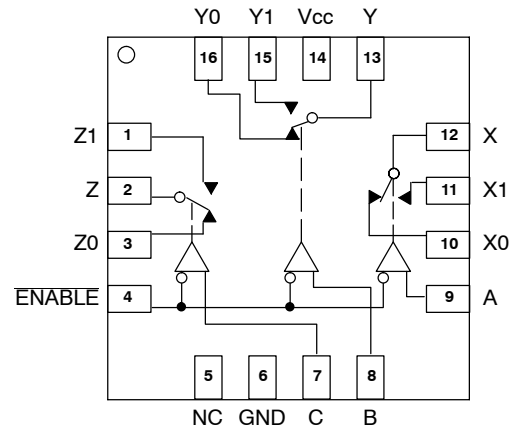

ORDERING INFORMATION

See detailed ordering and shipping information in the package dimensions section on page 10 of this data sheet.

*For additional information on our Pb-Free strategy and soldering details, please download the ON Semiconductor Soldering and Mounting Techniques Reference Manual, SOLDERRM/D.

NLAS4783B

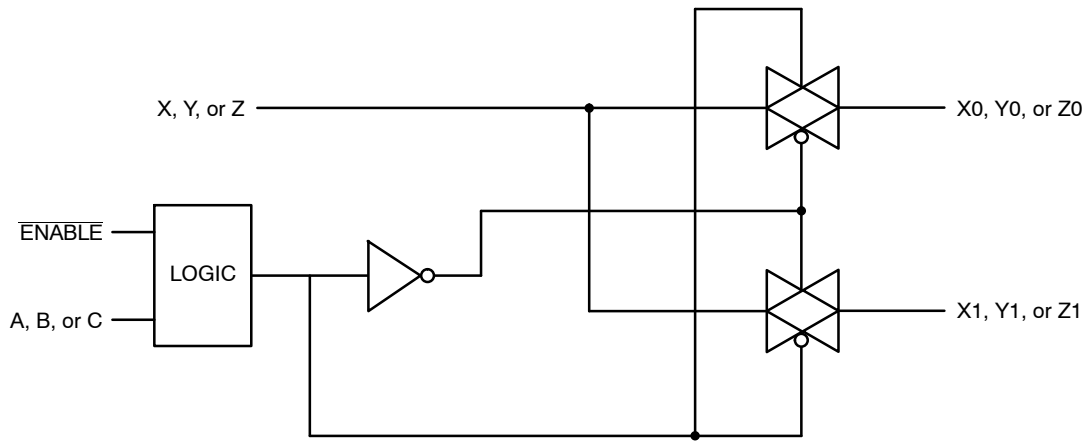

Figure 1. Input Equivalent Circuit

PIN FUNCTION DESCRIPTION

QFN PIN #	Symbol	Description
15	Y1	Analog Switch Y Normally Open Input
16	Y0	Analog Switch Y Normally Closed Input
1	Z1	Analog Switch Z Normally Open Input
2	Z	Analog Switch Z Output
3	Z0	Analog Switch Z Normally Closed Input
4	ENABLE	Digital Enable Input. Normally connect to GND. Drive to logic high to set all switches off.
5	NC	No Connection. Not internally connected.
6	GND	Ground
7	C	Digital Address C Input
8	B	Digital Address B Input
9	A	Digital Address A Input
10	X0	Analog Switch X Normally Closed Input
11	X1	Analog Switch X Normally Open Input
12	X	Analog Switch X Output
13	Y	Analog Switch Y Output
14	V _{CC}	Positive Analog and Digital Supply Voltage Input

NLAS4783B

TRUTH TABLE/SWITCH PROGRAMMING

Enable Input	Select Input			
	C	B	A	
H	X	X	X	All Switches Open
L	L	L	L	X-X0 Y-Y0 Z-Z0
L	L	L	H	X-X1 Y-Y0 Z-Z0
L	L	H	L	X-X0 Y-Y1 Z-Z0
L	L	H	H	X-X1 Y-Y1 Z-Z0
L	H	L	L	X-X0 Y-Y0 Z-Z1
L	H	L	H	X-X1 Y-Y0 Z-Z1
L	H	H	L	X-X0 Y-Y1 Z-Z1
L	H	H	H	X-X1 Y-Y1 Z-Z1

1. Input and output pins are identical and interchangeable. Both pins can be considered input or output. Bidirectional signal pass.

NLAS4783B

DC CHARACTERISTICS – Digital Section (Voltages Referenced to GND)

Symbol	Parameter	Condition	V _{CC}	Guaranteed Limit		Unit
				–40°C to 25°C	< 85°C	
V _{IH}	Minimum High-Level Input Voltage, Select Inputs		1.65	1.0	1.0	V
			2.7	1.4	1.4	
			3.6	1.8	1.8	
			4.3	2.2	2.2	
V _{IL}	Maximum Low-Level Input Voltage, Select Inputs		1.65	0.4	0.4	V
			2.7	0.5	0.5	
			3.6	0.6	0.6	
			4.3	0.8	0.8	
I _{IN}	Maximum Input Leakage Current, Select Inputs	V _{IN} = 4.5 V or GND	4.3	± 0.1	± 1.0	μA
I _{OFF}	Power Off Leakage Current	V _{IN} = 4.5 V or GND	0	± 0.5	± 2.0	μA
I _{CC}	Maximum Quiescent Supply Current (Note 3)	Select and V _{IS} = V _{CC} or GND	1.65 to 4.5	± 1.0	± 2.0	μA

DC ELECTRICAL CHARACTERISTICS – Analog Section

Symbol	Parameter	Condition	V _{CC}	Guaranteed Maximum Limit				Unit
				–40°C to 25°C		< 85°C		
				Min	Max	Min	Max	
R _{ON}	NC/NO On-Resistance (Note 3)	V _{IN} ≤ V _{IL} or V _{IN} ≥ V _{IH} V _{IS} = GND to V _{CC} I _{IN} ≤ 100 mA	2.7 – 4.3		1.0		1.2	Ω
R _{FLAT}	NC/NO On-Resistance Flatness (Notes 3, 5)	I _{COM} = 100 mA V _{IS} = 0 to V _{CC}	2.7 – 4.3		0.2		0.2	Ω
ΔR _{ON}	On-Resistance Match Between Channels (Notes 3 and 4)	V _{IS} = 0.5 V _{CC} ; I _{COM} = 100 mA	2.7 – 4.3		0.4		0.6	Ω
I _{NC(OFF)} I _{NO(OFF)}	NC or NO Off Leakage Current (Note 3)	V _{IN} = V _{IL} or V _{IH} V _{NO} or V _{NC} = 0.3 V V _{COM} = 4.0 V	4.3	–10	10	–100	100	nA
I _{COM(ON)}	COM ON Leakage Current (Note 3)	V _{IN} = V _{IL} or V _{IH} V _{NO} 0.3 V or 4.0 V with V _{NC} floating or V _{NC} 0.3 V or 4.0 V with V _{NO} floating V _{COM} = 0.3 V or 4.0 V	4.3	–10	10	–100	100	nA

3. Guaranteed by design. Resistance measurements do not include test circuit or package resistance.

4. $\Delta R_{ON} = R_{ON(MAX)} - R_{ON(MIN)}$ between NC1 and NC2 or between NO1 and NO2.

5. Flatness is defined as the difference between the maximum and minimum value of on-resistance as measured over the specified analog signal ranges.

NLAS4783B

AC ELECTRICAL CHARACTERISTICS (Input $t_r = t_f = 3.0$ ns)

Symbol	Parameter	Test Conditions	V_{CC} (V)	V_{IS} (V)	Guaranteed Maximum Limit					Unit
					-40°C to 25°C			< 85°C		
					Min	Typ*	Max	Min	Max	
t_{ON}	Turn-On Time	$R_L = 50 \Omega$, $C_L = 35$ pF (Figures 3 and 4)	2.3 – 4.5	1.5			25		27	ns
t_{OFF}	Turn-Off Time	$R_L = 50 \Omega$, $C_L = 35$ pF (Figures 3 and 4)	2.3 – 4.5	1.5			15		20	ns
t_{BBM}	Minimum Break-Before-Make Time	$V_{IS} = 3.0$ $R_L = 300 \Omega$, $C_L = 35$ pF (Figure 2)	3.0	1.5	2.0	8.0				ns

		Typical @ 25, $V_{CC} = 4.5$ V		
C_{IN}	Control Pin Input Capacitance	5.0		pF
C_{SN}	SN Port Capacitance	75		pF
C_D	D Port Capacitance When Switch is Enabled	240		pF

*Typical Characteristics are at 25°C.

ADDITIONAL APPLICATION CHARACTERISTICS (Voltages Referenced to GND Unless Noted)

Symbol	Parameter	Condition	V_{CC} (V)	25°C		Unit
				Typical		
BW	Maximum On-Channel -3dB Bandwidth or Minimum Frequency Response	V_{IN} centered between V_{CC} and GND (Figure 5)	1.65 – 4.5	17		MHz
V_{ONL}	Maximum Feed-through On Loss	$V_{IN} = 0$ dBm @ 100 kHz to 50 MHz V_{IN} centered between V_{CC} and GND (Figure 5)	1.65 – 4.5	-0.10		dB
V_{ISO}	Off-Channel Isolation	$f = 100$ kHz; $V_{IS} = 1$ V RMS; $C_L = 5$ nF V_{IN} centered between V_{CC} and GND (Figure 5) (Note 6)	1.65 – 4.5	-62		dB
Q	Charge Injection Select Input to Common I/O	$V_{IN} = V_{CC}$ to GND, $R_{IS} = 0 \Omega$, $C_L = 1$ nF $Q = C_L \times \Delta V_{OUT}$ (Figure 6)	1.65 – 4.5	50		pC
THD	Total Harmonic Distortion THD + Noise	$F_{IS} = 20$ Hz to 20 kHz, $R_L = R_{gen} = 600 \Omega$, $C_L = 50$ pF $V_{IS} = 2$ V RMS	4.5	0.008		%
VCT	Channel-to-Channel Crosstalk	$f = 100$ kHz; $V_{IS} = 1$ V RMS, $C_L = 5$ pF, $R_L = 50 \Omega$ V_{IN} centered between V_{CC} and GND (Figure 5)	1.65 – 4.5	-62		dB

6. Off-Channel Isolation = $20 \log_{10} (V_{com}/V_{no})$, V_{com} = output, V_{no} = input to off switch.

NLAS4783B

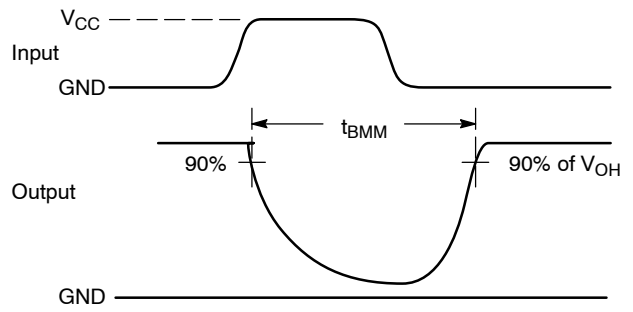
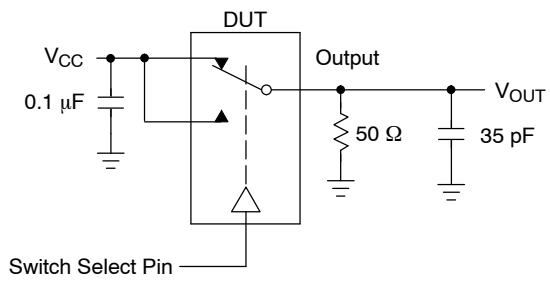

Figure 2. t_{BMM} (Time Break-Before-Make)

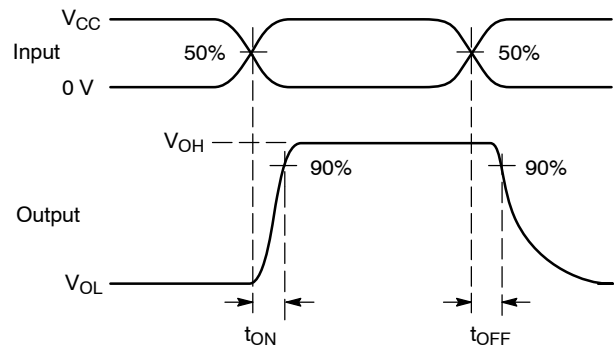
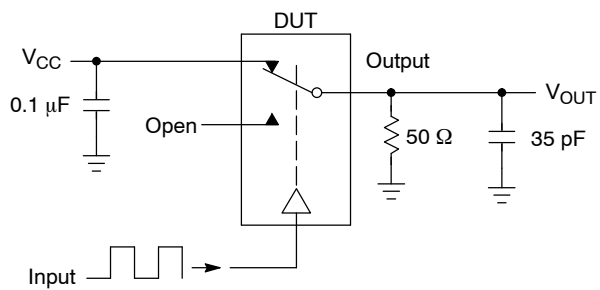

Figure 3. t_{ON}/t_{OFF}

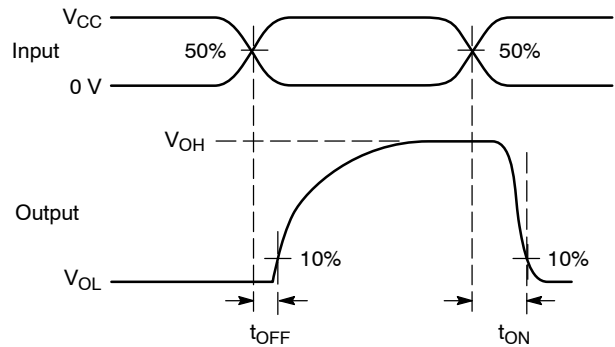
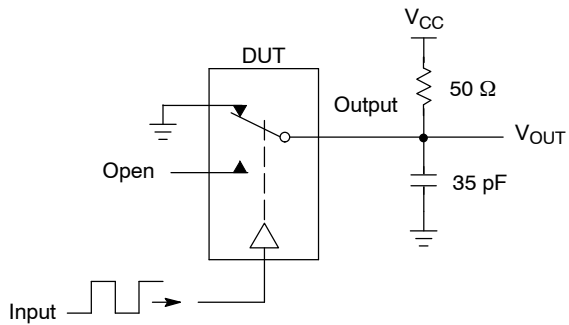
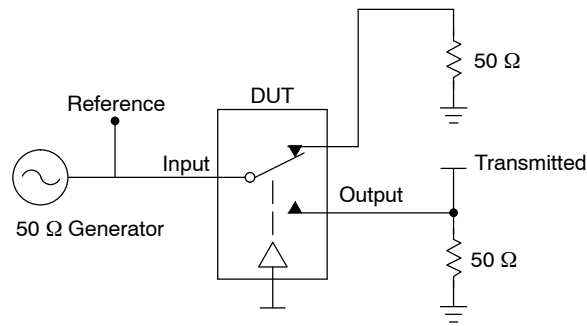

Figure 4. t_{ON}/t_{OFF}

NLAS4783B



Channel switch control/s test socket is normalized. Off isolation is measured across an off channel. On loss is the bandwidth of an On switch. V_{ISO} , Bandwidth and V_{ONL} are independent of the input signal direction.

$$V_{ISO} = \text{Off Channel Isolation} = 20 \text{ Log} \left(\frac{V_{OUT}}{V_{IN}} \right) \text{ for } V_{IN} \text{ at } 100 \text{ kHz}$$

$$V_{ONL} = \text{On Channel Loss} = 20 \text{ Log} \left(\frac{V_{OUT}}{V_{IN}} \right) \text{ for } V_{IN} \text{ at } 100 \text{ kHz to } 50 \text{ MHz}$$

Bandwidth (BW) = the frequency 3 dB below V_{ONL}

V_{CT} = Use V_{ISO} setup and test to all other switch analog input/outputs terminated with 50 Ω

Figure 5. Off Channel Isolation/On Channel Loss (BW)/Crosstalk (On Channel to Off Channel)/ V_{ONL}

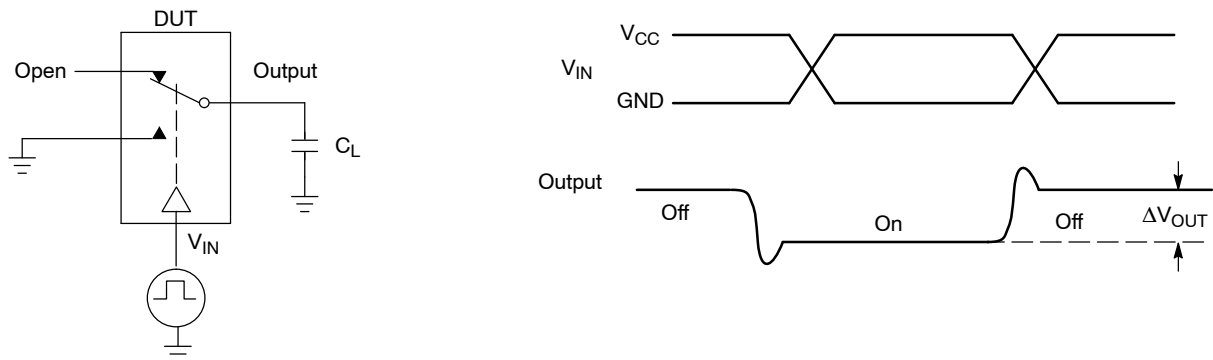

Figure 6. Charge Injection: (Q)

NLAS4783B

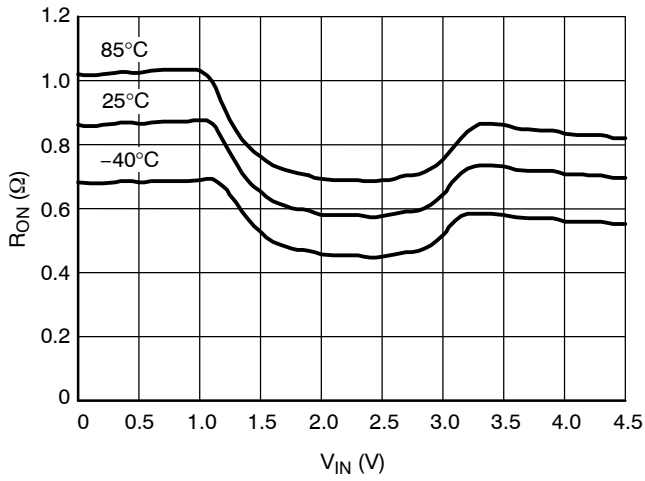

Figure 7. On-Resistance vs. Input Voltage @ $V_{CC} = 4.3\text{ V}$

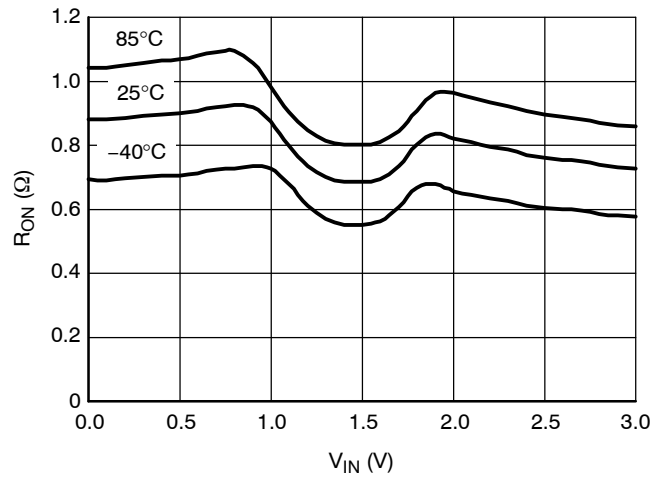

Figure 8. R_{ON} vs. V_{IN} vs. Temperature @ $V_{CC} = 3.0\text{ V}$

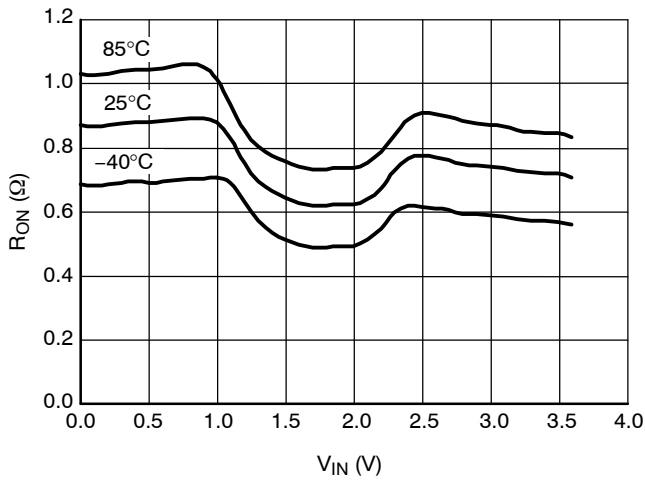

Figure 9. R_{ON} vs. V_{IN} vs. Temperature @ $V_{CC} = 3.6\text{ V}$

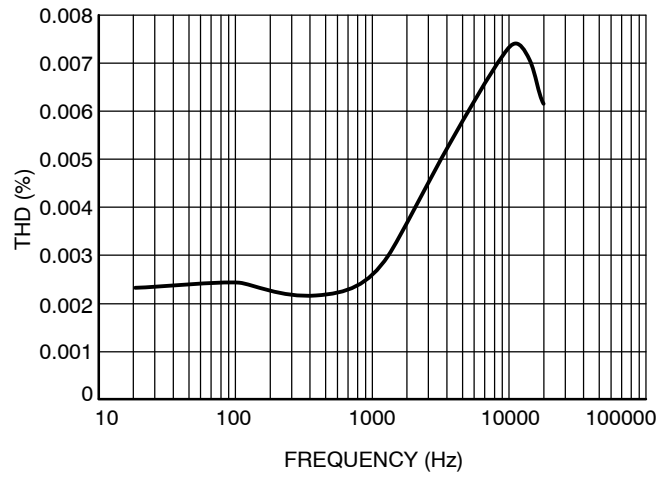

Figure 10. Total Harmonic Distortion vs. Frequency

NLAS4783B

ORDERING INFORMATION

Device Order Number	Device Nomenclature					Package Type	Tape & Reel Size [†]
	Circuit Indicator	Technology	Device Function	Package Suffix	Tape & Reel Suffix		
NLAS4783BMN1R2G	NL	AS	4783B	MN1	R2G	QFN (Pb-Free)	3000 Tape & Reel

[†]For information on tape and reel specifications, including part orientation and tape sizes, please refer to our Tape and Reel Packaging Specifications Brochure, BRD8011/D.

MECHANICAL CASE OUTLINE

PACKAGE DIMENSIONS

ON Semiconductor®



1
SCALE 2:1

QFN16 3x3, 0.5P
CASE 485AE
ISSUE C

DATE 24 JUN 2016

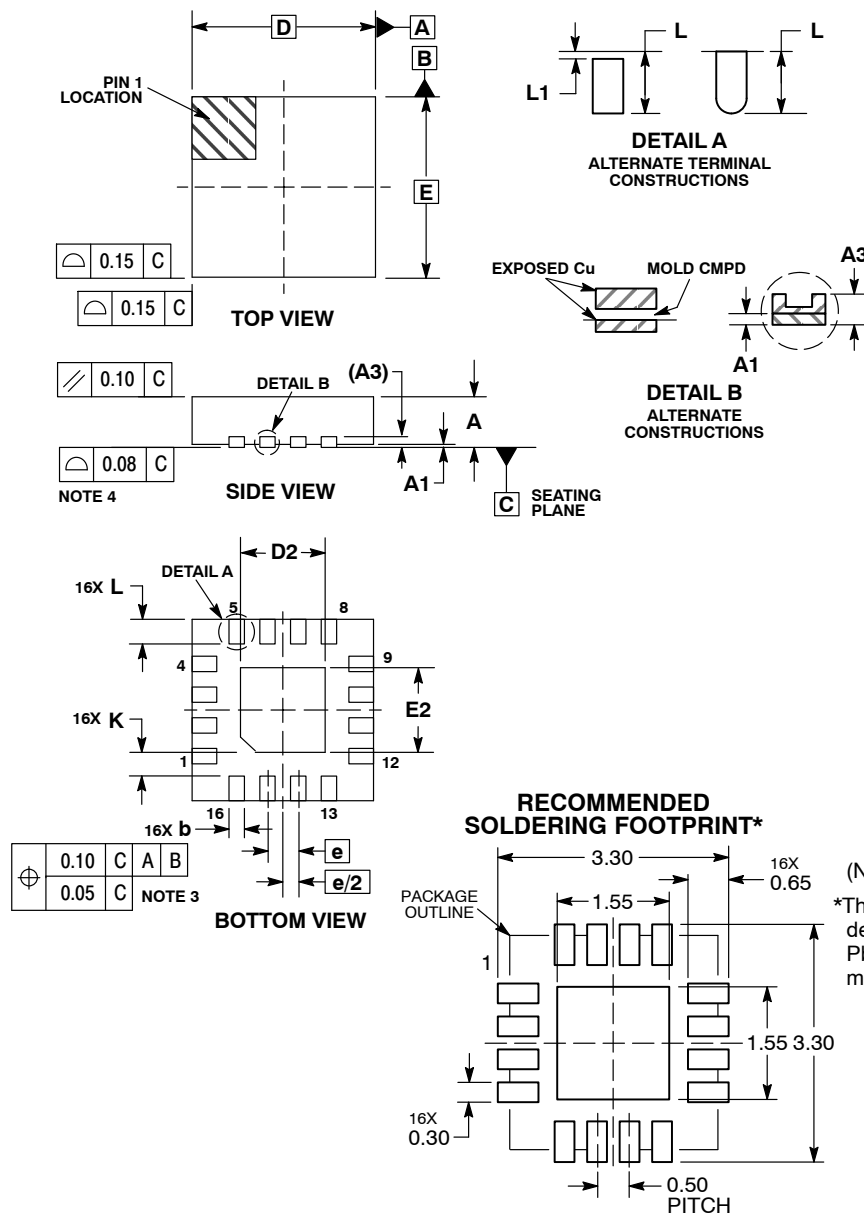

- NOTES:
1. DIMENSIONING AND TOLERANCING PER ASME Y14.5M, 1994.
 2. CONTROLLING DIMENSION: MILLIMETERS.
 3. DIMENSION b APPLIES TO PLATED TERMINAL AND IS MEASURED BETWEEN 0.25 AND 0.30 MM FROM TERMINAL.
 4. COPLANARITY APPLIES TO THE EXPOSED PAD AS WELL AS THE TERMINALS.
 5. OUTLINE MEETS JEDEC DIMENSIONS PER MO-220, VARIATION VEED-6.

DIM	MILLIMETERS	
	MIN	MAX
A	0.80	1.00
A1	0.00	0.05
A3	0.20	REF
b	0.18	0.30
D	3.00	BSC
D2	1.25	1.55
E	3.00	BSC
E2	1.25	1.55
e	0.50	BSC
K	0.20	---
L	0.30	0.50
L1	0.00	0.15

GENERIC MARKING DIAGRAM*

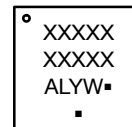

- A = Assembly Location
- L = Wafer Lot
- Y = Year
- W = Work Week
- = Pb-Free Package

(Note: Microdot may be in either location)

*This information is generic. Please refer to device data sheet for actual part marking. Pb-Free indicator, "G" or microdot "▪", may or may not be present.

*For additional information on our Pb-Free strategy and soldering details, please download the ON Semiconductor Soldering and Mounting Techniques Reference Manual, SOLDERRM/D.

DOCUMENT NUMBER:	98AON14949D	Electronic versions are uncontrolled except when accessed directly from the Document Repository. Printed versions are uncontrolled except when stamped "CONTROLLED COPY" in red.
DESCRIPTION:	QFN16 3X3, 0.5P	PAGE 1 OF 1

ON Semiconductor and ON are trademarks of Semiconductor Components Industries, LLC dba ON Semiconductor or its subsidiaries in the United States and/or other countries. ON Semiconductor reserves the right to make changes without further notice to any products herein. ON Semiconductor makes no warranty, representation or guarantee regarding the suitability of its products for any particular purpose, nor does ON Semiconductor assume any liability arising out of the application or use of any product or circuit, and specifically disclaims any and all liability, including without limitation special, consequential or incidental damages. ON Semiconductor does not convey any license under its patent rights nor the rights of others.

onsemi, **Onsemi**, and other names, marks, and brands are registered and/or common law trademarks of Semiconductor Components Industries, LLC dba "**onsemi**" or its affiliates and/or subsidiaries in the United States and/or other countries. **onsemi** owns the rights to a number of patents, trademarks, copyrights, trade secrets, and other intellectual property. A listing of **onsemi**'s product/patent coverage may be accessed at www.onsemi.com/site/pdf/Patent-Marking.pdf. **onsemi** reserves the right to make changes at any time to any products or information herein, without notice. The information herein is provided "as-is" and **onsemi** makes no warranty, representation or guarantee regarding the accuracy of the information, product features, availability, functionality, or suitability of its products for any particular purpose, nor does **onsemi** assume any liability arising out of the application or use of any product or circuit, and specifically disclaims any and all liability, including without limitation special, consequential or incidental damages. Buyer is responsible for its products and applications using **onsemi** products, including compliance with all laws, regulations and safety requirements or standards, regardless of any support or applications information provided by **onsemi**. "Typical" parameters which may be provided in **onsemi** data sheets and/or specifications can and do vary in different applications and actual performance may vary over time. All operating parameters, including "Typicals" must be validated for each customer application by customer's technical experts. **onsemi** does not convey any license under any of its intellectual property rights nor the rights of others. **onsemi** products are not designed, intended, or authorized for use as a critical component in life support systems or any FDA Class 3 medical devices or medical devices with a same or similar classification in a foreign jurisdiction or any devices intended for implantation in the human body. Should Buyer purchase or use **onsemi** products for any such unintended or unauthorized application, Buyer shall indemnify and hold **onsemi** and its officers, employees, subsidiaries, affiliates, and distributors harmless against all claims, costs, damages, and expenses, and reasonable attorney fees arising out of, directly or indirectly, any claim of personal injury or death associated with such unintended or unauthorized use, even if such claim alleges that **onsemi** was negligent regarding the design or manufacture of the part. **onsemi** is an Equal Opportunity/Affirmative Action Employer. This literature is subject to all applicable copyright laws and is not for resale in any manner.

PUBLICATION ORDERING INFORMATION

LITERATURE FULFILLMENT:

Email Requests to: orderlit@onsemi.com

onsemi Website: www.onsemi.com

TECHNICAL SUPPORT

North American Technical Support:

Voice Mail: 1 800-282-9855 Toll Free USA/Canada

Phone: 011 421 33 790 2910

Europe, Middle East and Africa Technical Support:

Phone: 00421 33 790 2910

For additional information, please contact your local Sales Representative

