

DDR3 SDRAM SODIMM

MT8JSF12864H – 1GB

MT8JSF25664H – 2GB

Features

- DDR3 functionality and operations supported as defined in the component data sheet
- 204-pin, small-outline dual in-line memory module (SODIMM)
- Fast data transfer rates: PC3-12800, PC3-10600, PC3-8500, or PC3-6400
- 1GB (128 Meg x 64) and 2GB (256 Meg x 64)
- $V_{DD} = 1.5V \pm 0.075V$
- $V_{DDSPD} = +3.0V$ to $+3.6V$
- Nominal and dynamic on-die termination (ODT) for data, strobe, and mask signals
- Single rank
- On-board I²C temperature sensor with integrated serial presence-detect (SPD) EEPROM
- 8 internal device banks
- Fixed burst chop (BC) of 4 and burst length (BL) of 8 via the mode register set (MRS)
- Selectable BC4 or BL8 on-the-fly (OTF)
- Gold edge contacts
- Lead-free
- Fly-by topology
- Terminated control, command, and address bus

Figure 1: 204-Pin SODIMM (MO-268 R/C B)

Module height: 30.0mm (1.18in)

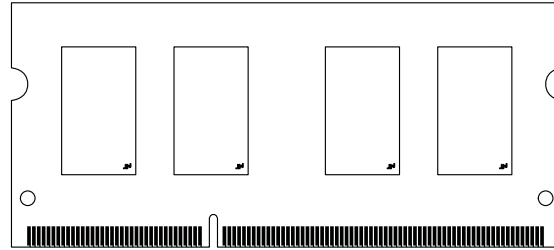

Options

- Operating temperature¹
 - Commercial ($0^{\circ}C \leq T_A \leq +70^{\circ}C$)
 - Industrial ($-40^{\circ}C \leq T_A \leq +85^{\circ}C$)
- Package
 - 204-pin lead-free DIMM
- Frequency/CAS latency
 - 1.25ns @ CL = 11 (DDR3-1600)
 - 1.5ns @ CL = 9 (DDR3-1333)
 - 1.87ns @ CL = 7 (DDR3-1066)

Marking

None
I
Y
-1G6
-1G4
-1G1

- Notes:
1. Contact Micron for industrial temperature module offerings.
 2. Not recommended for new designs.

Table 1: Key Timing Parameters

Speed Grade	Industry Nomenclature	Data Rate (MT/s)							t _{RCD} (ns)	t _{RP} (ns)	t _{RC} (ns)
		CL = 11	CL = 10	CL = 9	CL = 8	CL = 7	CL = 6	CL = 5			
-1G6	PC3-12800	1600	1333	1333	1066	1066	800	667	13.125	13.125	48.125
-1G4	PC3-10600	–	1333	1333	1066	1066	800	667	13.125	13.125	49.125
-1G1	PC3-8500	–	–	–	1066	1066	800	667	13.125	13.125	50.625
-1G0	PC3-8500	–	–	–	1066	–	800	667	15	15	52.5
-80B	PC3-6400	–	–	–	–	–	800	667	15	15	52.5



1GB, 2GB (x64, SR) 204-Pin DDR3 SDRAM SODIMM Features

Table 2: Addressing

Parameter	1GB	2GB
Refresh count	8K	8K
Row address	16K A[13:0]	32K A[14:0]
Device bank address	8 BA[2:0]	8 BA[2:0]
Device configuration	1Gb (128 Meg x 8)	2Gb (256 Meg x 8)
Column address	1K A[9:0]	1K A[9:0]
Module rank address	1 S0#	1 S0#

Table 3: Part Numbers and Timing Parameters – 1GB Modules

Base device: MT41J128M8,¹ 1Gb DDR3 SDRAM

Part Number ²	Module Density	Configuration	Module Bandwidth	Memory Clock/ Data Rate	Clock Cycles (CL- ^t RCD- ^t RP)
MT8JSF12864H(I)Y-1G6__	1GB	128 Meg x 64	12.8 GB/s	1.25ns/1600 MT/s	11-11-11
MT8JSF12864H(I)Y-1G4__	1GB	128 Meg x 64	10.6 GB/s	1.5ns/1333 MT/s	9-9-9
MT8JSF12864H(I)Y-1G1__	1GB	128 Meg x 64	8.5 GB/s	1.87ns/1066 MT/s	7-7-7

Table 4: Part Numbers and Timing Parameters – 2GB Modules

Base device: MT41J256M8,¹ 2Gb DDR3 SDRAM

Part Number ²	Module Density	Configuration	Module Bandwidth	Memory Clock/ Data Rate	Clock Cycles (CL- ^t RCD- ^t RP)
MT8JSF25664H(I)Y-1G6__	2GB	256 Meg x 64	12.8 GB/s	1.25ns/1600 MT/s	11-11-11
MT8JSF25664H(I)Y-1G4__	2GB	256 Meg x 64	10.6 GB/s	1.5ns/1333 MT/s	9-9-9
MT8JSF25664H(I)Y-1G1__	2GB	256 Meg x 64	8.5 GB/s	1.87ns/1066 MT/s	7-7-7

- Notes:
1. The data sheets for the base devices can be found on Micron's Web site.
 2. All part numbers end with a two-place code (not shown) that designates component and PCB revisions. Consult factory for current revision codes. Example: MT8JSF12864HY-1G1B1.



Pin Assignments

Table 5: Pin Assignments

204-Pin DDR3 SODIMM Front								204-Pin DDR3 SODIMM Back							
Pin	Symbol	Pin	Symbol	Pin	Symbol	Pin	Symbol	Pin	Symbol	Pin	Symbol	Pin	Symbol	Pin	Symbol
1	V _{REFDQ}	53	DQ19	105	V _{DD}	157	DQ42	2	V _{SS}	54	V _{SS}	106	V _{DD}	158	DQ46
3	V _{SS}	55	V _{SS}	107	A10	159	DQ43	4	DQ4	56	DQ28	108	BA1	160	DQ47
5	DQ0	57	DQ24	109	BA0	161	V _{SS}	6	DQ5	58	DQ29	110	RAS#	162	V _{SS}
7	DQ1	59	DQ25	111	V _{DD}	163	DQ48	8	V _{SS}	60	V _{SS}	112	V _{DD}	164	DQ52
9	V _{SS}	61	V _{SS}	113	WE#	165	DQ49	10	DQS0#	62	DQ3#	114	S0#	166	DQ53
11	DM0	63	DM3	115	CAS#	167	V _{SS}	12	DQS0	64	DQ3	116	ODT0	168	V _{SS}
13	V _{SS}	65	V _{SS}	117	V _{DD}	169	DQS6#	14	V _{SS}	66	V _{SS}	118	V _{DD}	170	DM6
15	DQ2	67	DQ26	119	A13	171	DQS6	16	DQ6	68	DQ30	120	NC	172	V _{SS}
17	DQ3	69	DQ27	121	NC	173	V _{SS}	18	DQ7	70	DQ31	122	NC	174	DQ54
19	V _{SS}	71	V _{SS}	123	V _{DD}	175	DQS0	20	V _{SS}	72	V _{SS}	124	V _{DD}	176	DQ55
21	DQ8	73	CKE0	125	NC	177	DQS1	22	DQ12	74	NC	126	V _{REFCA}	178	V _{SS}
23	DQ9	75	V _{DD}	127	V _{SS}	179	V _{SS}	24	DQ13	76	V _{DD}	128	V _{SS}	180	DQ60
25	V _{SS}	77	NC	129	DQ32	181	DQS6	26	V _{SS}	78	NC	130	DQ36	182	DQ61
27	DQS1#	79	BA2	131	DQ33	183	DQS7	28	DM1	80	NF/A14 ¹	132	DQ37	184	V _{SS}
29	DQS1	81	V _{DD}	133	V _{SS}	185	V _{SS}	30	RESET#	82	V _{DD}	134	V _{SS}	186	DQS7#
31	V _{SS}	83	A12	135	DQS4#	187	DM7	32	V _{SS}	84	A11	136	DM4	188	DQS7
33	DQ10	85	A9	137	DQS4	189	V _{SS}	34	DQ14	86	A7	138	V _{SS}	190	V _{SS}
35	DQ11	87	V _{DD}	139	V _{SS}	191	DQS8	36	DQ15	88	V _{DD}	140	DQ38	192	DQ62
37	V _{SS}	89	A8	141	DQ34	193	DQS9	38	V _{SS}	90	A6	142	DQ39	194	DQ63
39	DQ16	91	A5	143	DQ35	195	V _{SS}	40	DQ20	92	A4	144	V _{SS}	196	V _{SS}
41	DQ17	93	V _{DD}	145	V _{SS}	197	SA0	42	DQ21	94	V _{DD}	146	DQ44	198	EVENT#
43	V _{SS}	95	A3	147	DQ40	199	V _{DDSPD}	44	V _{SS}	96	A2	148	DQ45	200	SDA
45	DQS2#	97	A1	149	DQ41	201	SA1	46	DM2	98	A0	150	V _{SS}	202	SCL
47	DQS2	99	V _{DD}	151	V _{SS}	203	V _{TT}	48	V _{SS}	100	V _{DD}	152	DQS5#	204	V _{TT}
49	V _{SS}	101	CK0	153	DM5	-	-	50	DQ22	102	CK1	154	DQS5	-	-
51	DQ18	103	CK0#	155	V _{SS}	-	-	52	DQ23	104	CK1#	156	V _{SS}	-	-

Note: 1. Pin 80 is NF for 1GB and A14 for 2GB.

Pin Descriptions

The pin description table below is a comprehensive list of all possible pins for all DDR3 modules. All pins listed may not be supported on this module. See Pin Assignments for information specific to this module.

Table 6: Pin Descriptions

Symbol	Type	Description
Ax	Input	Address inputs: Provide the row address for ACTIVE commands, and the column address and auto precharge bit (A10) for READ/WRITE commands, to select one location out of the memory array in the respective bank. A10 sampled during a PRECHARGE command determines whether the PRECHARGE applies to one bank (A10 LOW, bank selected by BAx) or all banks (A10 HIGH). The address inputs also provide the op-code during a LOAD MODE command. See the Pin Assignments Table for density-specific addressing information.
BAx	Input	Bank address inputs: Define the device bank to which an ACTIVE, READ, WRITE, or PRECHARGE command is being applied. BA define which mode register (MR0, MR1, MR2, or MR3) is loaded during the LOAD MODE command.
CKx, CKx#	Input	Clock: Differential clock inputs. All control, command, and address input signals are sampled on the crossing of the positive edge of CK and the negative edge of CK#.
CKEx	Input	Clock enable: Enables (registered HIGH) and disables (registered LOW) internal circuitry and clocks on the DRAM.
DMx	Input	Data mask (x8 devices only): DM is an input mask signal for write data. Input data is masked when DM is sampled HIGH, along with that input data, during a write access. Although DM pins are input-only, DM loading is designed to match that of the DQ and DQS pins.
ODTx	Input	On-die termination: Enables (registered HIGH) and disables (registered LOW) termination resistance internal to the DDR3 SDRAM. When enabled in normal operation, ODT is only applied to the following pins: DQ, DQS, DQS#, DM, and CB. The ODT input will be ignored if disabled via the LOAD MODE command.
Par_In	Input	Parity input: Parity bit for Ax, RAS#, CAS#, and WE#.
RAS#, CAS#, WE#	Input	Command inputs: RAS#, CAS#, and WE# (along with S#) define the command being entered.
RESET#	Input (LVCMOS)	Reset: RESET# is an active LOW asynchronous input that is connected to each DRAM and the registering clock driver. After RESET# goes HIGH, the DRAM must be reinitialized as though a normal power-up was executed.
Sx#	Input	Chip select: Enables (registered LOW) and disables (registered HIGH) the command decoder.
SAx	Input	Serial address inputs: Used to configure the temperature sensor/SPD EEPROM address range on the I ² C bus.
SCL	Input	Serial clock for temperature sensor/SPD EEPROM: Used to synchronize communication to and from the temperature sensor/SPD EEPROM on the I ² C bus.
CBx	I/O	Check bits: Used for system error detection and correction.
DQx	I/O	Data input/output: Bidirectional data bus.
DQSx, DQSx#	I/O	Data strobe: Differential data strobes. Output with read data; edge-aligned with read data; input with write data; center-aligned with write data.

Table 6: Pin Descriptions (Continued)

Symbol	Type	Description
SDA	I/O	Serial data: Used to transfer addresses and data into and out of the temperature sensor/SPD EEPROM on the I ² C bus.
TDQSx, TDQSx#	Output	Redundant data strobe (x8 devices only): TDQS is enabled/disabled via the LOAD MODE command to the extended mode register (EMR). When TDQS is enabled, DM is disabled and TDQS and TDQS# provide termination resistance; otherwise, TDQS# are no function.
Err_Out#	Output (open drain)	Parity error output: Parity error found on the command and address bus.
EVENT#	Output (open drain)	Temperature event: The EVENT# pin is asserted by the temperature sensor when critical temperature thresholds have been exceeded.
V _{DD}	Supply	Power supply: 1.5V ±0.075V. The component V _{DD} and V _{DDQ} are connected to the module V _{DD} .
V _{DDSPD}	Supply	Temperature sensor/SPD EEPROM power supply: 3.0–3.6V.
V _{REFCA}	Supply	Reference voltage: Control, command, and address V _{DD} /2.
V _{REFDQ}	Supply	Reference voltage: DQ, DM V _{DD} /2.
V _{SS}	Supply	Ground.
V _{TT}	Supply	Termination voltage: Used for control, command, and address V _{DD} /2.
NC	–	No connect: These pins are not connected on the module.
NF	–	No function: These pins are connected within the module, but provide no functionality.

DQ Map

Table 7: Component-to-Module DQ Map

Component Reference Number	Component DQ	Module DQ	Module Pin Number	Component Reference Number	Component DQ	Module DQ	Module Pin Number
U1	0	2	15	U2	0	22	50
	1	1	7		1	17	41
	2	6	16		2	18	51
	3	5	6		3	21	42
	4	7	18		4	23	52
	5	0	5		5	16	39
	6	3	17		6	19	53
	7	4	4		7	20	40
U3	0	34	141	U4	0	50	175
	1	36	130		1	53	166
	2	38	140		2	54	174
	3	33	131		3	49	165
	4	35	143		4	55	176
	5	32	129		5	48	163
	6	39	142		6	51	177
	7	37	132		7	52	164
U6	0	61	182	U7	0	45	148
	1	62	192		1	42	157
	2	57	183		2	44	146
	3	58	191		3	46	158
	4	60	180		4	40	147
	5	59	193		5	47	160
	6	56	181		6	41	149
	7	63	194		7	43	159
U8	0	29	58	U9	0	9	23
	1	26	67		1	10	33
	2	25	59		2	13	24
	3	31	70		3	11	35
	4	24	57		4	12	22
	5	30	68		5	15	36
	6	28	56		6	8	21
	7	27	69		7	14	34

Functional Block Diagram

Figure 2: Functional Block Diagram

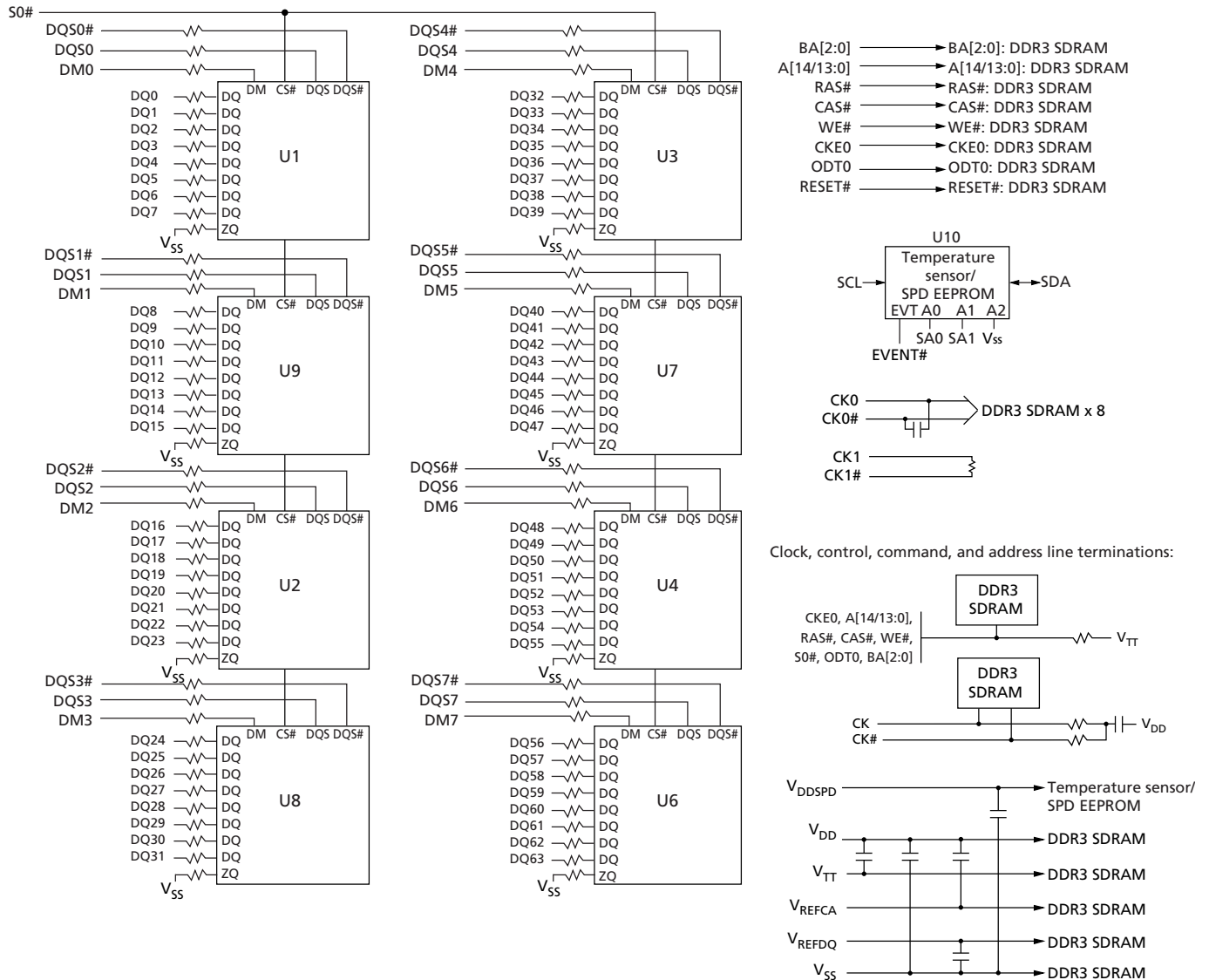

Note: 1. The ZQ ball on each DDR3 component is connected to an external 240Ω ±1% resistor that is tied to ground. It is used for the calibration of the component's ODT and output driver.

General Description

DDR3 SDRAM modules are high-speed, CMOS dynamic random access memory modules that use internally configured 8-bank DDR3 SDRAM devices. DDR3 SDRAM modules use DDR architecture to achieve high-speed operation. DDR3 architecture is essentially a $8n$ -prefetch architecture with an interface designed to transfer two data words per clock cycle at the I/O pins. A single read or write access for the DDR3 SDRAM module effectively consists of a single $8n$ -bit-wide, one-clock-cycle data transfer at the internal DRAM core and eight corresponding n -bit-wide, one-half-clock-cycle data transfers at the I/O pins.

DDR3 modules use two sets of differential signals: DQS, DQS# to capture data and CK and CK# to capture commands, addresses, and control signals. Differential clocks and data strobes ensure exceptional noise immunity for these signals and provide precise crossing points to capture input signals.

Fly-By Topology

DDR3 modules use faster clock speeds than earlier DDR technologies, making signal quality more important than ever. For improved signal quality, the clock, control, command, and address buses have been routed in a fly-by topology, where each clock, control, command, and address pin on each DRAM is connected to a single trace and terminated (rather than a tree structure, where the termination is off the module near the connector). Inherent to fly-by topology, the timing skew between the clock and DQS signals can be easily accounted for by using the write-leveling feature of DDR3.

Temperature Sensor with Serial Presence-Detect EEPROM

Thermal Sensor Operations

The temperature from the integrated thermal sensor is monitored and converts into a digital word via the I²C bus. System designers can use the user-programmable registers to create a custom temperature-sensing solution based on system requirements. Programming and configuration details comply with JEDEC standard No. 21-C page 4.7-1, "Definition of the TSE2002av, Serial Presence Detect with Temperature Sensor."

Serial Presence-Detect EEPROM Operation

DDR3 SDRAM modules incorporate serial presence-detect. The SPD data is stored in a 256-byte EEPROM. The first 128 bytes are programmed by Micron to comply with JEDEC standard JC-45, "Appendix X: Serial Presence Detect (SPD) for DDR3 SDRAM Modules." These bytes identify module-specific timing parameters, configuration information, and physical attributes. The remaining 128 bytes of storage are available for use by the customer. System READ/WRITE operations between the master (system logic) and the slave EEPROM device occur via a standard I²C bus using the DIMM's SCL (clock) SDA (data), and SA (address) pins. Write protect (WP) is connected to V_{SS}, permanently disabling hardware write protection. For further information refer to Micron technical note TN-04-42, "Memory Module Serial Presence-Detect."

Electrical Specifications

Stresses greater than those listed may cause permanent damage to the module. This is a stress rating only, and functional operation of the module at these or any other conditions outside those indicated in each device's data sheet is not implied. Exposure to absolute maximum rating conditions for extended periods may adversely affect reliability.

Table 8: Absolute Maximum Ratings

Symbol	Parameter	Min	Max	Units
V_{DD}	V_{DD} supply voltage relative to V_{SS}	-0.4	1.975	V
V_{IN}, V_{OUT}	Voltage on any pin relative to V_{SS}	-0.4	1.975	V

Table 9: Operating Conditions

Symbol	Parameter	Min	Nom	Max	Units	Notes	
V_{DD}	V_{DD} supply voltage	1.425	1.5	1.575	V		
$V_{REFCA(DC)}$	Input reference voltage command/address bus	$0.49 \times V_{DD}$	$0.5 \times V_{DD}$	$0.51 \times V_{DD}$	V		
$V_{REFDQ(DC)}$	I/O reference voltage DQ bus	$0.49 \times V_{DD}$	$0.5 \times V_{DD}$	$0.51 \times V_{DD}$	V		
I_{VTT}	Termination reference current from V_{TT}	-600	-	+600	mA		
V_{TT}	Termination reference voltage (DC) – command/address bus	$0.49 \times V_{DD} - 20\text{mV}$	$0.5 \times V_{DD}$	$0.51 \times V_{DD} + 20\text{mV}$	V	1	
I_I	Input leakage current; Any input $0V \leq V_{IN} \leq V_{DD}$; V_{REF} input $0V \leq V_{IN} \leq 0.95V$ (All other pins not under test = $0V$)	Address inputs, RAS#, CAS#, WE#, S#, CKE, ODT, BA, CK, CK#	-16	0	16	μA	
		DM	-2	0	2		
I_{OZ}	Output leakage current; $0V \leq V_{OUT} \leq V_{DD}$; DQ and ODT are disabled; ODT is HIGH	DQ, DQS, DQS#	-5	0	5	μA	
I_{VREF}	V_{REF} supply leakage current; $V_{REFDQ} = V_{DD}/2$ or $V_{REFCA} = V_{DD}/2$ (All other pins not under test = $0V$)		-8	0	8	μA	
T_A	Module ambient operating temperature	Commercial	0	-	70	$^{\circ}\text{C}$	2, 3
		Industrial	-40	-	85	$^{\circ}\text{C}$	
T_C	DDR3 SDRAM component case operating temperature	Commercial	0	-	85	$^{\circ}\text{C}$	2, 3, 4
		Industrial	-40	-	95	$^{\circ}\text{C}$	

- Notes:
- V_{TT} termination voltage in excess of the stated limit will adversely affect the command and address signals' voltage margin and will reduce timing margins.
 - T_A and T_C are simultaneous requirements.
 - For further information, refer to technical note TN-00-08: "Thermal Applications," available on Micron's Web site.
 - The refresh rate is required to double when $85^{\circ}\text{C} < T_C \leq 95^{\circ}\text{C}$.



DRAM Operating Conditions

Recommended AC operating conditions are given in the DDR3 component data sheets. Component specifications are available on Micron's Web site. Module speed grades correlate with component speed grades, as shown below.

Table 10: Module and Component Speed Grades

DDR3 components may exceed the listed module speed grades; module may not be available in all listed speed grades

Module Speed Grade	Component Speed Grade
-1G9	-107
-1G6	-125
-1G4	-15E
-1G1	-187E
-1G0	-187
-80C	-25E
-80B	-25

Design Considerations

Simulations

Micron memory modules are designed to optimize signal integrity through carefully designed terminations, controlled board impedances, routing topologies, trace length matching, and decoupling. However, good signal integrity starts at the system level. Micron encourages designers to simulate the signal characteristics of the system's memory bus to ensure adequate signal integrity of the entire memory system.

Power

Operating voltages are specified at the DRAM, not at the edge connector of the module. Designers must account for any system voltage drops at anticipated power levels to ensure the required supply voltage is maintained.



I_{DD} Specifications

Table 11: DDR3 I_{DD} Specifications and Conditions – 1GB

Values are for the MT41J128M8 DDR3 SDRAM only and are computed from values specified in the 1Gb (128 Meg x 8) component data sheet

Parameter	Symbol	1600	1333	1066	Units
Operating current 0: One bank ACTIVATE-to-PRECHARGE	I _{DD0}	960	880	800	mA
Operating current 1: One bank ACTIVATE-to-READ-to-PRECHARGE	I _{DD1}	1120	1040	960	mA
Precharge power-down current: Slow exit	I _{DD2P0}	96	96	96	mA
Precharge power-down current: Fast exit	I _{DD2P1}	360	320	280	mA
Precharge quiet standby current	I _{DD2Q}	536	480	424	mA
Precharge standby current	I _{DD2N}	560	520	440	mA
Precharge standby ODT current	I _{DD2NT}	760	680	600	mA
Active power-down current	I _{DD3P}	360	320	280	mA
Active standby current	I _{DD3N}	536	496	456	mA
Burst read operating current	I _{DD4R}	2000	1600	1280	mA
Burst write operating current	I _{DD4W}	2000	1760	1520	mA
Refresh current	I _{DD5}	2080	1920	1760	mA
Self refresh temperature current: MAX T _C = 85°C	I _{DD6}	48	48	48	mA
Self refresh temperature current (SRT-enabled): MAX T _C = 95°C	I _{DD6ET}	72	72	72	mA
All banks interleaved read current	I _{DD7}	4800	3920	3120	mA
Reset current	I _{DD8}	112	112	112	mA

Table 12: DDR3 I_{DD} Specifications and Conditions – 2GB

Values are for the MT41J256M8 DDR3 SDRAM only and are computed from values specified in the 2Gb (256 Meg x 8) component data sheet

Parameter	Symbol	1600	1333	1066	Units
Operating current 0: One bank ACTIVATE-to-PRECHARGE	I _{DD0}	560	720	640	mA
Operating current 1: One bank ACTIVATE-to-READ-to-PRECHARGE	I _{DD1}	680	920	800	mA
Precharge power-down current: Slow exit	I _{DD2P0}	96	96	96	mA
Precharge power-down current: Fast exit	I _{DD2P1}	240	280	240	mA
Precharge quiet standby current	I _{DD2Q}	360	520	440	mA
Precharge standby current	I _{DD2N}	360	520	440	mA
Precharge standby ODT current	I _{DD2NT}	480	680	600	mA
Active power-down current	I _{DD3P}	280	360	320	mA
Active standby current	I _{DD3N}	400	600	480	mA
Burst read operating current	I _{DD4R}	1000	1600	1280	mA
Burst write operating current	I _{DD4W}	1240	1920	1600	mA
Refresh current	I _{DD5}	1800	2040	1960	mA
Self refresh temperature current: MAX T _C = 85°C	I _{DD6}	72	72	72	mA
Self refresh temperature current (SRT-enabled): MAX T _C = 95°C	I _{DD6ET}	96	96	96	mA
All banks interleaved read current	I _{DD7}	2320	2920	2560	mA
Refresh current	I _{DD8}	112	112	112	mA



Temperature Sensor with Serial Presence-Detect EEPROM

The temperature sensor continuously monitors the module's temperature and can be read back at any time over the I²C bus shared with the SPD EEPROM.

Serial Presence-Detect

For the latest SPD data, refer to Micron's SPD page: www.micron.com/SPD.

Table 13: Temperature Sensor with SPD EEPROM Operating Conditions

Parameter/Condition	Symbol	Min	Max	Units
Supply voltage	V _{DDSPD}	3.0	3.6	V
Supply current: V _{DD} = 3.3V	I _{DD}	–	2.0	mA
Input high voltage: Logic 1; SCL, SDA	V _{IH}	1.45	V _{DDSPD} + 1	V
Input low voltage: Logic 0; SCL, SDA	V _{IL}	–	0.55	V
Output low voltage: I _{OUT} = 2.1mA	V _{OL}	–	0.4	V
Input current	I _{IN}	–5.0	5.0	μA
Temperature sensing range	–	–40	125	°C
Temperature sensor accuracy (class B)	–	–1.0	1.0	°C

Table 14: Temperature Sensor and EEPROM Serial Interface Timing

Parameter/Condition	Symbol	Min	Max	Units
Time bus must be free before a new transition can start	t _{BUF}	4.7	–	μs
SDA fall time	t _F	20	300	ns
SDA rise time	t _R	–	1000	ns
Data hold time	t _{HD:DAT}	200	900	ns
Start condition hold time	t _{H:STA}	4.0	–	μs
Clock HIGH period	t _{HIGH}	4.0	50	μs
Clock LOW period	t _{LOW}	4.7	–	μs
SCL clock frequency	t _{SCL}	10	100	kHz
Data setup time	t _{SU:DAT}	250	–	ns
Start condition setup time	t _{SU:STA}	4.7	–	μs
Stop condition setup time	t _{SU:STO}	4.0	–	μs

EVENT# Pin

The temperature sensor also adds the EVENT# pin (open-drain). Not used by the SPD EEPROM, EVENT# is a temperature sensor output used to flag critical events that can be set up in the sensor's configuration register.

EVENT# has three defined modes of operation: interrupt mode, compare mode, and critical temperature mode. Event thresholds are programmed in the 0x01 register using a hysteresis. The alarm window provides a comparison window, with upper and lower limits set in the alarm upper boundary register and the alarm lower boundary register, respectively. When the alarm window is enabled, EVENT# will trigger whenever the temperature is outside the MIN or MAX values set by the user.

The interrupt mode enables software to reset EVENT# after a critical temperature threshold has been detected. Threshold points are set in the configuration register by the user. This mode triggers the critical temperature limit and both the MIN and MAX of the temperature window.

The compare mode is similar to the interrupt mode, except EVENT# cannot be reset by the user and returns to the logic HIGH state only when the temperature falls below the programmed thresholds.

Critical temperature mode triggers EVENT# only when the temperature has exceeded the programmed critical trip point. When the critical trip point has been reached, the temperature sensor goes into comparator mode, and the critical EVENT# cannot be cleared through software.

Module Dimensions

Figure 3: 204-Pin DDR3 SODIMM

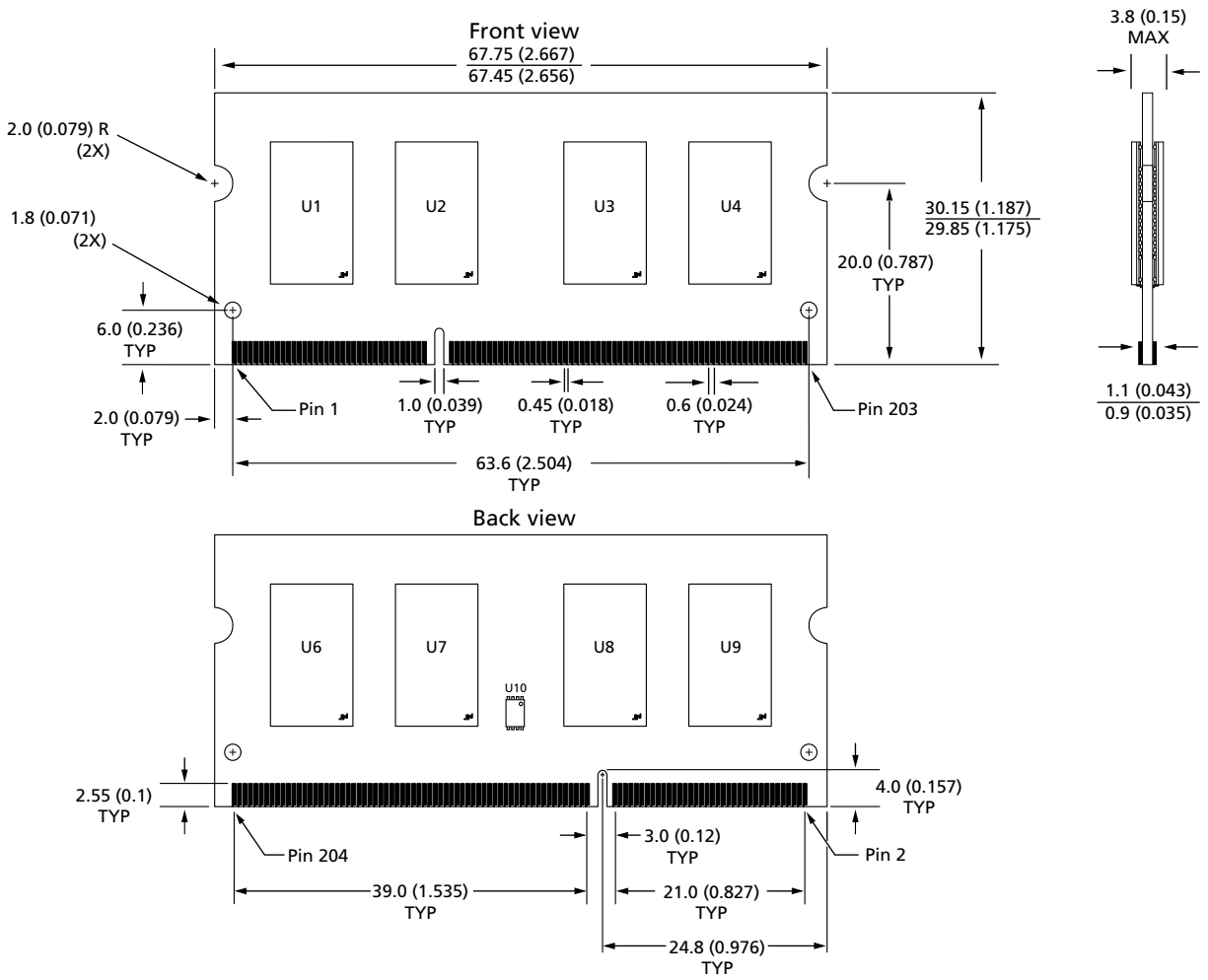

- Notes: 1. All dimensions are in millimeters (inches); MAX/MIN or typical (TYP) where noted.
 2. The dimensional diagram is for reference only.

8000 S. Federal Way, P.O. Box 6, Boise, ID 83707-0006, Tel: 208-368-3900
 www.micron.com/productsupport Customer Comment Line: 800-932-4992
 Micron and the Micron logo are trademarks of Micron Technology, Inc.
 All other trademarks are the property of their respective owners.

This data sheet contains minimum and maximum limits specified over the power supply and temperature range set forth herein. Although considered final, these specifications are subject to change, as further product development and data characterization sometimes occur.