

Phase Locked Loop

MC14046B

The MC14046B phase locked loop contains two phase comparators, a voltage-controlled oscillator (VCO), source follower, and zener diode. The comparators have two common signal inputs, PCA_{in} and PCB_{in}. Input PCA_{in} can be used directly coupled to large voltage signals, or indirectly coupled (with a series capacitor) to small voltage signals. The self-bias circuit adjusts small voltage signals in the linear region of the amplifier. Phase comparator 1 (an exclusive OR gate) provides a digital error signal PC1_{out}, and maintains 90° phase shift at the center frequency between PCA_{in} and PCB_{in} signals (both at 50% duty cycle). Phase comparator 2 (with leading edge sensing logic) provides digital error signals, PC2_{out} and LD, and maintains a 0° phase shift between PCA_{in} and PCB_{in} signals (duty cycle is immaterial). The linear VCO produces an output signal VCO_{out} whose frequency is determined by the voltage of input VCO_{in} and the capacitor and resistors connected to pins C1_A, C1_B, R1, and R2. The source-follower output SF_{out} with an external resistor is used where the VCO_{in} signal is needed but no loading can be tolerated. The inhibit input Inh, when high, disables the VCO and source follower to minimize standby power consumption. The zener diode can be used to assist in power supply regulation.

Applications include FM and FSK modulation and demodulation, frequency synthesis and multiplication, frequency discrimination, tone decoding, data synchronization and conditioning, voltage-to-frequency conversion and motor speed control.

Features

- Buffered Outputs Compatible with Low-Power TTL
- Diode Protection on All Inputs
- Supply Voltage Range = 3.0 to 18 V
- Pin-for-Pin Replacement for CD4046B
- Phase Comparator 1 is an Exclusive OR Gate and is Duty Cycle Limited
- Phase Comparator 2 Switches on Rising Edges and is not Duty Cycle Limited
- NLV Prefix for Automotive and Other Applications Requiring Unique Site and Control Change Requirements; AEC-Q100 Qualified and PPAP Capable
- These Devices are Pb-Free and are RoHS Compliant

MAXIMUM RATINGS (Voltages Referenced to V_{SS})

Symbol	Parameter	Value	Unit
V _{DD}	DC Supply Voltage Range	-0.5 to +18.0	V
V _{in}	Input Voltage Range (All Inputs)	-0.5 to V _{DD} + 0.5	V
I _{in}	DC Input Current, per Pin	±10	mA
P _D	Power Dissipation, per Package (Note 1)	500	mW
T _A	Operating Temperature Range	-55 to +125	°C
T _{stg}	Storage Temperature Range	-65 to +150	°C

Stresses exceeding those listed in the Maximum Ratings table may damage the device. If any of these limits are exceeded, device functionality should not be assumed, damage may occur and reliability may be affected.

1. Temperature Derating: "D/DW" Packages: -7.0 mW/°C From 65°C To 125°C

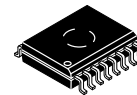

SOIC-16 WB
DW SUFFIX
CASE 751G

MARKING DIAGRAM

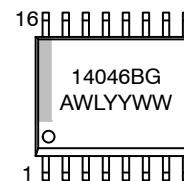

SOIC-16 WB

- A = Assembly Location
- WL, L = Wafer Lot
- YY, Y = Year
- WW, W = Work Week
- G = Pb-Free Indicator

ORDERING INFORMATION

See detailed ordering and shipping information in the package dimensions section on page 6 of this data sheet.

This device contains protection circuitry to guard against damage due to high static voltages or electric fields. However, precautions must be taken to avoid applications of any voltage higher than maximum rated voltages to this high-impedance circuit. For proper operation, V_{in} and V_{out} should be constrained to the range V_{SS} ≤ (V_{in} or V_{out}) ≤ V_{DD}.

Unused inputs must always be tied to an appropriate logic voltage level (e.g., either V_{SS} or V_{DD}). Unused outputs must be left open.

MC14046B

BLOCK DIAGRAM

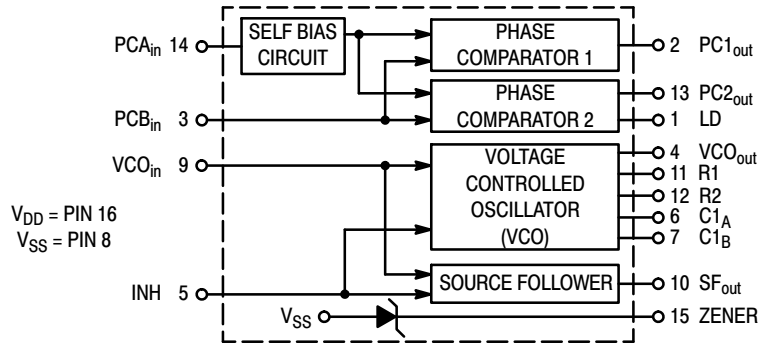

PIN ASSIGNMENT

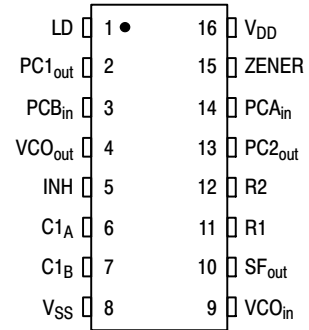

ELECTRICAL CHARACTERISTICS (Voltages Referenced to V_{SS})

Characteristic	Symbol	V _{DD} Vdc	- 55 °C		25 °C			125 °C		Unit		
			Min	Max	Min	Typ	Max	Min	Max			
Output Voltage V _{in} = V _{DD} or 0	"0" Level	V _{OL}	5.0	-	0.05	-	0	0.05	-	0.05	Vdc	
			10	-	0.05	-	0	0.05	-	0.05		
			15	-	0.05	-	0	0.05	-	0.05		
	V _{in} = 0 or V _{DD}	"1" Level	V _{OH}	5.0	4.95	-	4.95	5.0	-	4.95	-	Vdc
				10	9.95	-	9.95	10	-	9.95	-	
				15	14.95	-	14.95	15	-	14.95	-	
Input Voltage (Note 2) (V _O = 4.5 or 0.5 Vdc) (V _O = 9.0 or 1.0 Vdc) (V _O = 13.5 or 1.5 Vdc)	"0" Level	V _{IL}	5.0	-	1.5	-	2.25	1.5	-	1.5	Vdc	
			10	-	3.0	-	4.50	3.0	-	3.0		
			15	-	4.0	-	6.75	4.0	-	4.0		
	(V _O = 0.5 or 4.5 Vdc) (V _O = 1.0 or 9.0 Vdc) (V _O = 1.5 or 13.5 Vdc)	"1" Level	V _{IH}	5.0	3.5	-	3.5	2.75	-	3.5	-	Vdc
				10	7.0	-	7.0	5.50	-	7.0	-	
				15	11	-	11	8.25	-	11	-	
Output Drive Current (V _{OH} = 2.5 Vdc) (V _{OH} = 4.6 Vdc) (V _{OH} = 9.5 Vdc) (V _{OH} = 13.5 Vdc)	Source	I _{OH}	5.0	-1.2	-	-1.0	-1.7	-	-0.7	-	mAdc	
			10	-0.25	-	-0.2	-0.36	-	-0.14	-		
			15	-0.62	-	-0.5	-0.9	-	-0.35	-		
	(V _{OL} = 0.4 Vdc) (V _{OL} = 0.5 Vdc) (V _{OL} = 1.5 Vdc)	Sink	I _{OL}	5.0	0.64	-	0.51	0.88	-	0.36	-	mAdc
				10	1.6	-	1.3	2.25	-	0.9	-	
				15	4.2	-	3.4	8.8	-	2.4	-	
Input Current	I _{in}	15	-	±0.1	-	±0.00001	±0.1	-	±1.0	μAdc		
Input Capacitance	C _{in}	-	-	-	-	5.0	7.5	-	-	pF		
Quiescent Current (Per Package) Inh = PCA _{in} = V _{DD} , Zener = VCO _{in} = 0 V, PCB _{in} = V _{DD} or 0 V, I _{out} = 0 μA	I _{DD}	5.0	-	5.0	-	0.005	5.0	-	150	μAdc		
		10	-	10	-	0.010	10	-	300			
		15	-	20	-	0.015	20	-	600			
Total Supply Current (Note 3) (Inh = "0", f _o = 10 kHz, C _L = 50 pF, R1 = 1.0 MΩ, R2 = ∞, R _{SF} = ∞, and 50% Duty Cycle)	I _T	5.0	I _T = (1.46 μA/kHz) f + I _{DD}							mAdc		
		10	I _T = (2.91 μA/kHz) f + I _{DD}									
		15	I _T = (4.37 μA/kHz) f + I _{DD}									

Product parametric performance is indicated in the Electrical Characteristics for the listed test conditions, unless otherwise noted. Product performance may not be indicated by the Electrical Characteristics if operated under different conditions.

2. Noise immunity specified for worst-case input combination.

Noise Margin for both "1" and "0" level =
 1.0 Vdc min @ V_{DD} = 5.0 Vdc
 2.0 Vdc min @ V_{DD} = 10 Vdc
 2.5 Vdc min @ V_{DD} = 15 Vdc

3. To Calculate Total Current in General:

$$I_T \approx 2.2 \times V_{DD} \left(\frac{V_{CO_{in}} - 1.65}{R1} + \frac{V_{DD} - 1.35}{R2} \right)^{3/4} + 1.6 \times \left(\frac{V_{CO_{in}} - 1.65}{R_{SF}} \right)^{3/4} + 1 \times 10^{-3} (C_L + 9) V_{DD} f +$$

$$1 \times 10^{-1} V_{DD}^2 \left(\frac{100\% \text{ Duty Cycle of PCA}_{in}}{100} \right) + I_Q \quad \text{where: } I_T \text{ in } \mu\text{A}, C_L \text{ in pF, } V_{CO_{in}}, V_{DD} \text{ in Vdc, } f \text{ in kHz, and } R1, R2, R_{SF} \text{ in M}\Omega, C_L \text{ on VCO}_{out}$$

MC14046B

ELECTRICAL CHARACTERISTICS (Note 4) ($C_L = 50$ pF, $T_A = 25^\circ\text{C}$)

Characteristic	Symbol	V_{DD} Vdc	Minimum	Typical	Maximum	Units
			Device		Device	
Output Rise Time $t_{TLH} = (3.0 \text{ ns/pF}) C_L + 30 \text{ ns}$ $t_{TLH} = (1.5 \text{ ns/pF}) C_L + 15 \text{ ns}$ $t_{TLH} = (1.1 \text{ ns/pF}) C_L + 10 \text{ ns}$	t_{TLH}	5.0 10 15	– – –	180 90 65	350 150 110	ns
Output Fall Time $t_{THL} = (1.5 \text{ ns/pF}) C_L + 25 \text{ ns}$ $t_{THL} = (0.75 \text{ ns/pF}) C_L + 12.5 \text{ ns}$ $t_{THL} = (0.55 \text{ ns/pF}) C_L + 9.5 \text{ ns}$	t_{THL}	5.0 10 15	– – –	100 50 37	175 75 55	ns

PHASE COMPARATORS 1 and 2

Input Resistance – PCA_{in}	R_{in}	5.0	1.0	2.0	–	$M\Omega$
		10	0.2	0.4	–	
		15	0.1	0.2	–	
– PCB_{in}	R_{in}	15	150	1500	–	$M\Omega$
Minimum Input Se–sitivity AC Coupled — PCA_{in} C series = 1000 pF, $f = 50$ kHz	V_{in}	5.0	–	200	300	mV p–p
		10	–	400	600	
		15	–	700	1050	
DC Coupled – PCA_{in} , PCB_{in}	–	5 to 15	See Noise Immunity			

VOLTAGE CONTROLLED OSCILLATOR (VCO)

Maximum Frequency ($VCO_{in} = V_{DD}$, $C1 = 50$ pF $R1 = 5.0$ k Ω , and $R2 = \infty$)	f_{max}	5.0	0.5	0.7	–	MHz
		10	1.0	1.4	–	
		15	1.4	1.9	–	
Temperature – Frequency Stability ($R2 = \infty$)	–	5.0	–	0.12	–	%/ $^\circ\text{C}$
		10	–	0.04	–	
		15	–	0.015	–	
Linearity ($R2 = \infty$) ($VCO_{in} = 2.5 \text{ V} \pm 0.3 \text{ V}$, $R1 > 10$ k Ω) ($VCO_{in} = 5.0 \text{ V} \pm 2.5 \text{ V}$, $R1 > 400$ k Ω) ($VCO_{in} = 7.5 \text{ V} \pm 5.0 \text{ V}$, $R1 \geq 1000$ k Ω)	–	5.0	–	1.0	–	%
		10	–	1.0	–	
		15	–	1.0	–	
Output Duty Cycle	–	5 to 15	–	50	–	%
Input Resistance – VCO_{in}	R_{in}	15	150	1500	–	$M\Omega$

SOURCE–FOLLOWER

Offset Voltage (VCO_{in} minus SF_{out} , $RSF > 500$ k Ω)	–	5.0	–	1.65	2.2	V
		10	–	1.65	2.2	
		15	–	1.65	2.2	
Linearity ($VCO_{in} = 2.5 \text{ V} \pm 0.3 \text{ V}$, $RSF > 50$ k Ω) ($VCO_{in} = 5.0 \text{ V} \pm 2.5 \text{ V}$, $RSF > 50$ k Ω) ($VCO_{in} = 7.5 \text{ V} \pm 5.0 \text{ V}$, $RSF > 50$ k Ω)	–	5.0	–	0.1	–	%
		10	–	0.6	–	
		15	–	0.8	–	

ZENER DIODE

Zener Voltage ($I_z = 50$ μA)	V_Z	–	6.7	7.0	7.3	V
Dynamic Resistance ($I_z = 1.0$ mA)	R_Z	–	–	100	–	Ω

4. The formula given is for the typical characteristics only.

MC14046B

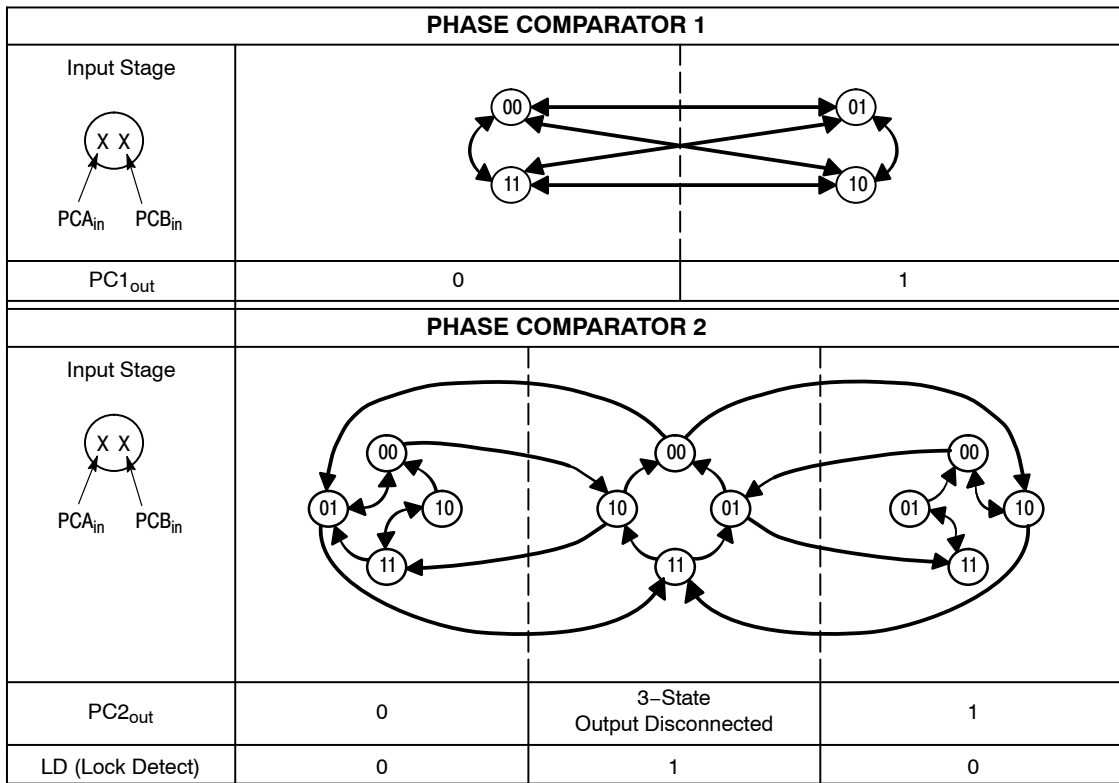

Refer to Waveforms in Figure 3.

Figure 1. Phase Comparators State Diagrams

Characteristic	Using Phase Comparator 1	Using Phase Comparator 2
No signal on input PCA _{in} .	VCO in PLL system adjusts to center frequency (f ₀).	VCO in PLL system adjusts to minimum frequency (f _{min}).
Phase angle between PCA _{in} and PCB _{in} .	90° at center frequency (f ₀), approaching 0° and 180° at ends of lock range (2f _L)	Always 0° in lock (positive rising edges).
Locks on harmonics of center frequency.	Yes	No
Signal input noise rejection.	High	Low
Lock frequency range (2f _L).	The frequency range of the input signal on which the loop will stay locked if it was initially in lock; 2f _L = full VCO frequency range = f _{max} - f _{min} .	
Capture frequency range (2f _C).	The frequency range of the input signal on which the loop will lock if it was initially out of lock.	
	Depends on low-pass filter characteristics (see Figure 3). f _C ≤ f _L	f _C = f _L
Center frequency (f ₀).	The frequency of VCO _{out} , when VCO _{in} = 1/2 V _{DD}	
VCO output frequency (f).	$f_{min} = \frac{1}{R_2(C_1 + 32 \text{ pF})} \quad (V_{CO} \text{ input} = V_{SS})$ $f_{max} = \frac{1}{R_1(C_1 + 32 \text{ pF})} + f_{min} \quad (V_{CO} \text{ input} = V_{DD})$ <p>Where: 10K ≤ R₁ ≤ 1 M 10K ≤ R₂ ≤ 1 M 100pF ≤ C₁ ≤ .01 μF</p>	
Note: These equations are intended to be a design guide. Since calculated component values may be in error by as much as a factor of 4, laboratory experimentation may be required for fixed designs. Part to part frequency variation with identical passive components is typically less than ± 20%.		

Figure 2. Design Information

MC14046B

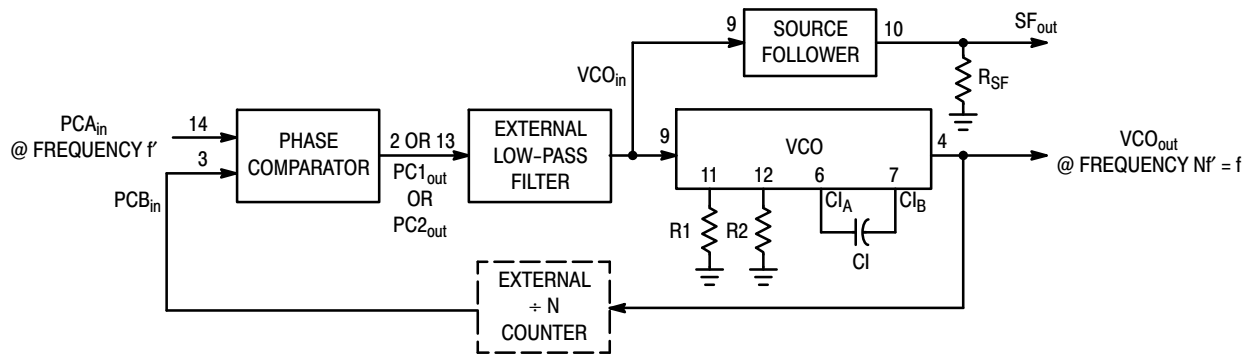

Typical Low-Pass Filters

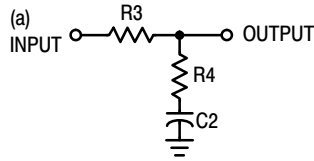
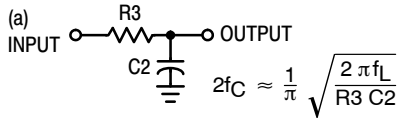

Typically:

$$R_4 C_2 = \frac{6N}{f_{\max}} - \frac{N}{2\pi \Delta f}$$

$$(R_3 + 3,000\Omega) C_2 = \frac{100N\Delta f}{f_{\max}^2} - R_4 C_2$$

$$\Delta f = f_{\max} - f_{\min}$$

NOTE: Sometimes R3 is split into two series resistors each R3 ÷ 2. A capacitor C_C is then placed from the midpoint to ground. The value for C_C should be such that the corner frequency of this network does not significantly affect Ω_n. In Figure B, the ratio of R3 to R4 sets the damping, R4 ≅ (0.1)(R3) for optimum results.

LOW-PASS FILTER

Definitions: N = Total division ratio in feedback loop
 $K\phi = V_{DD}/\pi$ for Phase Comparator 1
 $K\phi = V_{DD}/4\pi$ for Phase Comparator 2
 $KVCO = \frac{2\pi \Delta f VCO}{V_{DD} - 2V}$
 for a typical design $\Omega_n \cong \frac{2\pi f_r}{10}$ (at phase detector input)
 $\zeta \cong 0.707$

Filter A	Filter B
$\omega_n = \sqrt{\frac{K\phi KVCO}{NR_3 C_2}}$	$\omega_n = \sqrt{\frac{K\phi KVCO}{NC_2(R_3 + R_4)}}$
$\zeta = \frac{N\omega_n}{2K\phi KVCO}$	$\zeta = 0.5 \omega_n (R_3 C_2 + \frac{N}{K\phi KVCO})$
$F(s) = \frac{1}{R_3 C_2 S + 1}$	$F(s) = \frac{R_3 C_2 S + 1}{S(R_3 C_2 + R_4 C_2) + 1}$

Waveforms

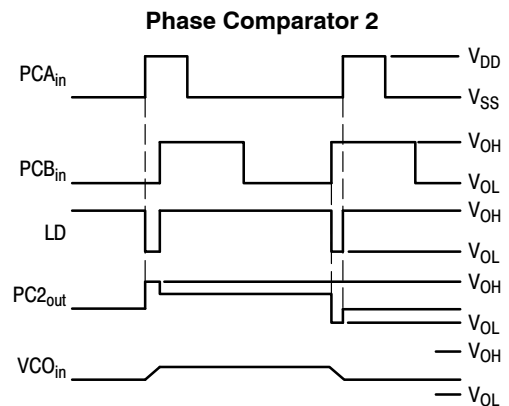
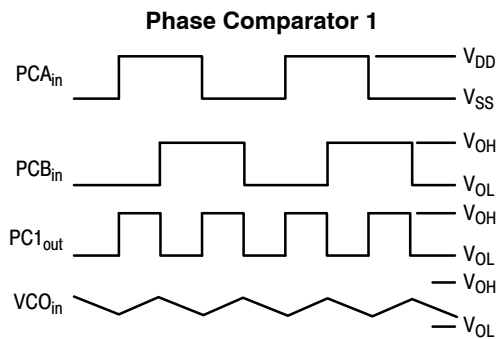

Note: for further information, see:

- (1) F. Gardner, "Phase-Lock Techniques", John Wiley and Son, New York, 1966.
- (2) G. S. Moschytz, "Miniature RC Filters Using Phase-Locked Loop", BSTJ, May, 1965.
- (3) Garth Nash, "Phase-Lock Loop Design Fundamentals", AN-535, Motorola Inc.
- (4) A. B. Przedpelski, "Phase-Locked Loop Design Articles", AR254, reprinted by Motorola Inc.

Figure 3. General Phase-Locked Loop Connections and Waveforms

MC14046B

ORDERING INFORMATION

Device	Package	Shipping†
MC14046BDWG	SOIC-16 WB (Pb-Free)	47 Units / Tube
MC14046BDWR2G	SOIC-16 WB (Pb-Free)	1000 Units / Tape & Reel

†For information on tape and reel specifications, including part orientation and tape sizes, please refer to our Tape and Reel Packaging Specifications Brochure, BRD8011/D.

*NLV Prefix for Automotive and Other Applications Requiring Unique Site and Control Change Requirements; AEC-Q100 Qualified and PPAP Capable.

MECHANICAL CASE OUTLINE PACKAGE DIMENSIONS

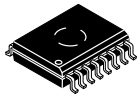

1
SCALE 1:1

SOIC-16 WB
CASE 751G
ISSUE E

DATE 08 OCT 2021

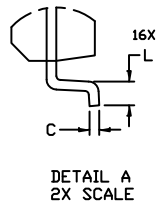
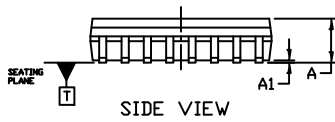
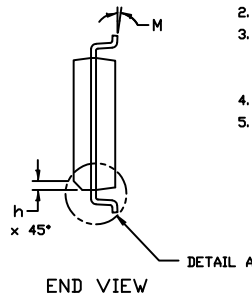
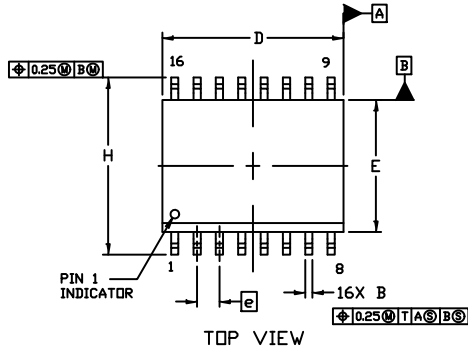

- NOTES:
- DIMENSIONING AND TOLERANCING PER ASME Y14.5M, 1994.
 - CONTROLLING DIMENSION: MILLIMETERS
 - DIMENSION *b* DOES NOT INCLUDE DAMBAR PROTRUSION. ALLOWABLE PROTRUSION SHALL BE 0.13 TOTAL IN EXCESS OF *B* DIMENSION AT MAXIMUM MATERIAL CONDITION.
 - DIMENSIONS *D* AND *E* DO NOT INCLUDE MOLD PROTRUSIONS.
 - MAXIMUM MOLD PROTRUSION OR FLASH TO BE 0.15 PER SIDE.

DIM	MILLIMETERS	
	MIN.	MAX.
A	2.35	2.65
A1	0.10	0.25
B	0.35	0.49
C	0.23	0.32
D	10.15	10.45
E	7.40	7.60
e	1.27 BSC	
H	10.05	10.55
h	0.53 REF	
L	0.50	0.90
M	0°	7°

GENERIC MARKING DIAGRAM*

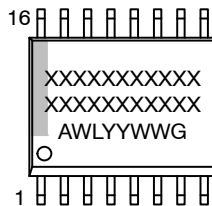

- XXXXX = Specific Device Code
- A = Assembly Location
- WL = Wafer Lot
- YY = Year
- WW = Work Week
- G = Pb-Free Package

*This information is generic. Please refer to device data sheet for actual part marking. Pb-Free indicator, "G" or microdot "▪", may or may not be present. Some products may not follow the Generic Marking.

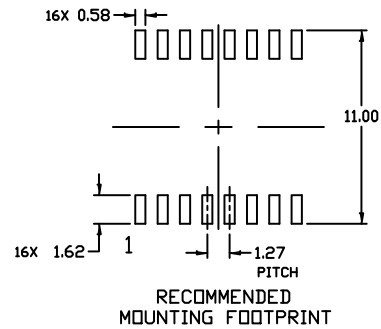

DOCUMENT NUMBER:	98ASB42567B	Electronic versions are uncontrolled except when accessed directly from the Document Repository. Printed versions are uncontrolled except when stamped "CONTROLLED COPY" in red.
DESCRIPTION:	SOIC-16 WB	PAGE 1 OF 1

onsemi and ONSEMI are trademarks of Semiconductor Components Industries, LLC dba onsemi or its subsidiaries in the United States and/or other countries. onsemi reserves the right to make changes without further notice to any products herein. onsemi makes no warranty, representation or guarantee regarding the suitability of its products for any particular purpose, nor does onsemi assume any liability arising out of the application or use of any product or circuit, and specifically disclaims any and all liability, including without limitation special, consequential or incidental damages. onsemi does not convey any license under its patent rights nor the rights of others.

onsemi, **Onsemi**, and other names, marks, and brands are registered and/or common law trademarks of Semiconductor Components Industries, LLC dba "**onsemi**" or its affiliates and/or subsidiaries in the United States and/or other countries. **onsemi** owns the rights to a number of patents, trademarks, copyrights, trade secrets, and other intellectual property. A listing of **onsemi**'s product/patent coverage may be accessed at www.onsemi.com/site/pdf/Patent-Marking.pdf. **onsemi** reserves the right to make changes at any time to any products or information herein, without notice. The information herein is provided "as-is" and **onsemi** makes no warranty, representation or guarantee regarding the accuracy of the information, product features, availability, functionality, or suitability of its products for any particular purpose, nor does **onsemi** assume any liability arising out of the application or use of any product or circuit, and specifically disclaims any and all liability, including without limitation special, consequential or incidental damages. Buyer is responsible for its products and applications using **onsemi** products, including compliance with all laws, regulations and safety requirements or standards, regardless of any support or applications information provided by **onsemi**. "Typical" parameters which may be provided in **onsemi** data sheets and/or specifications can and do vary in different applications and actual performance may vary over time. All operating parameters, including "Typicals" must be validated for each customer application by customer's technical experts. **onsemi** does not convey any license under any of its intellectual property rights nor the rights of others. **onsemi** products are not designed, intended, or authorized for use as a critical component in life support systems or any FDA Class 3 medical devices or medical devices with a same or similar classification in a foreign jurisdiction or any devices intended for implantation in the human body. Should Buyer purchase or use **onsemi** products for any such unintended or unauthorized application, Buyer shall indemnify and hold **onsemi** and its officers, employees, subsidiaries, affiliates, and distributors harmless against all claims, costs, damages, and expenses, and reasonable attorney fees arising out of, directly or indirectly, any claim of personal injury or death associated with such unintended or unauthorized use, even if such claim alleges that **onsemi** was negligent regarding the design or manufacture of the part. **onsemi** is an Equal Opportunity/Affirmative Action Employer. This literature is subject to all applicable copyright laws and is not for resale in any manner.

PUBLICATION ORDERING INFORMATION

LITERATURE FULFILLMENT:

Email Requests to: orderlit@onsemi.com

onsemi Website: www.onsemi.com

TECHNICAL SUPPORT

North American Technical Support:

Voice Mail: 1 800-282-9855 Toll Free USA/Canada

Phone: 011 421 33 790 2910

Europe, Middle East and Africa Technical Support:

Phone: 00421 33 790 2910

For additional information, please contact your local Sales Representative

