

ON Semiconductor

Is Now

onsemi™

To learn more about onsemi™, please visit our website at
www.onsemi.com

onsemi and **onsemi** and other names, marks, and brands are registered and/or common law trademarks of Semiconductor Components Industries, LLC dba "**onsemi**" or its affiliates and/or subsidiaries in the United States and/or other countries. **onsemi** owns the rights to a number of patents, trademarks, copyrights, trade secrets, and other intellectual property. A listing of **onsemi** product/patent coverage may be accessed at www.onsemi.com/site/pdf/Patent-Marking.pdf. **onsemi** reserves the right to make changes at any time to any products or information herein, without notice. The information herein is provided "as-is" and **onsemi** makes no warranty, representation or guarantee regarding the accuracy of the information, product features, availability, functionality, or suitability of its products for any particular purpose, nor does **onsemi** assume any liability arising out of the application or use of any product or circuit, and specifically disclaims any and all liability, including without limitation special, consequential or incidental damages. Buyer is responsible for its products and applications using **onsemi** products, including compliance with all laws, regulations and safety requirements or standards, regardless of any support or applications information provided by **onsemi**. "Typical" parameters which may be provided in **onsemi** data sheets and/or specifications can and do vary in different applications and actual performance may vary over time. All operating parameters, including "Typicals" must be validated for each customer application by customer's technical experts. **onsemi** does not convey any license under any of its intellectual property rights nor the rights of others. **onsemi** products are not designed, intended, or authorized for use as a critical component in life support systems or any FDA Class 3 medical devices or medical devices with a same or similar classification in a foreign jurisdiction or any devices intended for implantation in the human body. Should Buyer purchase or use **onsemi** products for any such unintended or unauthorized application, Buyer shall indemnify and hold **onsemi** and its officers, employees, subsidiaries, affiliates, and distributors harmless against all claims, costs, damages, and expenses, and reasonable attorney fees arising out of, directly or indirectly, any claim of personal injury or death associated with such unintended or unauthorized use, even if such claim alleges that **onsemi** was negligent regarding the design or manufacture of the part. **onsemi** is an Equal Opportunity/Affirmative Action Employer. This literature is subject to all applicable copyright laws and is not for resale in any manner. Other names and brands may be claimed as the property of others.

LE2416DXA

16 kb I²C CMOS Serial EEPROM



ON Semiconductor®

www.onsemi.com

Overview

The LE2416DXA is two-wire serial interface EEPROM (Electrically Erasable and Programmable ROM). This device realizes high speed and a high level reliability by high performance CMOS EEPROM technology. This device is compatible with I²C memory protocol, therefore it is best suited for application that requires re-writable nonvolatile parameter memory.

Function

- Capacity : 16k bits (2k × 8 bits)
- Single supply voltage : 1.7 V to 3.6 V
- Operating temperature : -40°C to +85°C
- Interface : Two wire serial interface (I²C Bus*)
- Operating clock frequency : 400 kHz (Fast), 1000 kHz (Fast-Plus)
- Low Power consumption
 - : Standby : 2 μA (max.)
 - : Active (Read, 400 kHz) : 0.5 mA (max.)
 - : Active (Read, 1000 kHz) : 2.0 mA (max.)
- Automatic page write mode : 16 Bytes
- Read mode : Sequential Read and random read
- Slave Address : Slave address in 7 bit format is 0x50 or 0x54 depending of polarity of pin B3 (TEST)
- Erase/Write cycles : 10⁶ cycles (Page Write)
- Data Retention : 20 years
- High reliability : Adopts proprietary symmetric memory array configuration (USP6947325)
 - Hardware write protect feature
 - Noise filters connected to SCL and SDA pins
 - Incorporates a feature to prohibit write operations under low voltage conditions.
- Package : LE2416DXA WLP6(0.80×1.20) 0.33 mm height

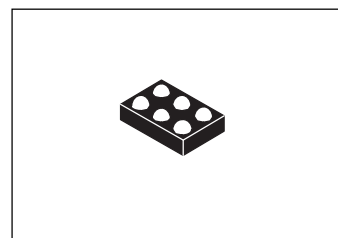

WLCSP6, 0.80x1.20

Specifications

Absolute Maximum Ratings at Ta = 25°C

Parameter	Symbol	Conditions	Ratings	Unit
Supply voltage			-0.5 to +4.6	V
DC input voltage			-0.5 to V _{CC} +0.5	V
Over-shoot voltage			-1.0 to V _{CC} +1.0	V
Storage temperature	Tstg		-65 to +150	°C

Stresses exceeding those listed in the Maximum Ratings table may damage the device. If any of these limits are exceeded, device functionality should not be assumed, damage may occur and reliability may be affected.

* This product is licensed from Silicon Storage Technology, Inc. (USA).

ORDERING INFORMATION

See detailed ordering and shipping information on page 17 of this data sheet.

Recommended Operating Conditions

Parameter	Symbol	Conditions	Ratings			Unit
			min	typ	max	
Operating supply voltage			1.7		3.6	V
Operating temperature			-40		+85	°C

Functional operation above the stresses listed in the Recommended Operating Ranges is not implied. Extended exposure to stresses beyond the Recommended Operating Ranges limits may affect device reliability.

DC Electrical Characteristics

Parameter	Symbol	Conditions	Spec.			Unit
			min	typ	max	
Supply current at reading	I _{CC1}	f = 400 kHz, V _{CC} = V _{CC} Max			0.5	mA
		f = 1000 kHz, V _{CC} = V _{CC} Max			2.0	
Supply current at writing	I _{CC2}	f = 1000 kHz / 400 kHz, t _{WC} = 5 ms, V _{CC} = V _{CC} Max			3.0	mA
Standby current	I _{SB}	WP = V _{CC} ² = V _{CC} V _{IN} = V _{CC} or V _{SS}			2	μA
Input leakage current	I _{LI}	V _{IN} = V _{SS} to V _{CC} , V _{CC} = V _{CC} Max	-2.0		+2.0	μA
Output leakage current	I _{LO}	V _{IN} = V _{SS} to V _{CC} , V _{CC} = V _{CC} Max	-2.0		+2.0	μA
Input Low voltage	V _{IL}				V _{CC} × 0.3	V
Input High voltage	V _{IH}		V _{CC} × 0.7			V
Output Low voltage	V _{OL2}	I _{OL} = 1.0 mA, V _{CC} = 1.7 V			0.2	V
		I _{OL} = 1.2 mA, V _{CC} = 2.0 V				
	V _{OL1}	I _{OL} = 2.1 mA, V _{CC} = 2.0 V			0.4	V
		I _{OL} = 3.0 mA, V _{CC} = 2.5 V				

Capacitance at Ta = 25°C, f = 1 MHz

Parameter	Symbol	Conditions	max	Unit
In/Output pin capacitance	C _{I/O}	V _{I/O} = 0 V (SDA)	10	pF
Input pin capacitance	C _I	V _{IN} = 0 V	10	pF

Product parametric performance is indicated in the Electrical Characteristics for the listed test conditions, unless otherwise noted. Product performance may not be indicated by the Electrical Characteristics if operated under different conditions.

Fast-Plus (1000 kHz)

Parameter	Symbol	Spec.			Unit
		min	typ	max	
Slave mode SCL clock frequency	f_{SCLS}	0		1000	kHz
SCL clock low time	t_{LOW}	500			ns
SCL clock high time	t_{HIGH}	300			ns
SDA output delay time	t_{AA}	50		450	ns
SDA data output hold time	t_{DH}	50			ns
Start condition setup time	$t_{SU,STA}$	250			ns
Start condition hold time	$t_{HD,STA}$	250			ns
Data in setup time	$t_{SU,DAT}$	50			ns
Data in hold time	$t_{HD,DAT}$	0			ns
Stop condition setup time	$t_{SU,STO}$	250			ns
SCL SDA rise time	t_R			120	ns
SCL SDA fall time	t_F			120	ns
Bus release time	t_{BUF}	500			ns
Noise suppression time	t_{SP}			50	ns
Write time	t_{WC}			5	ms

Fast (400 kHz)

Parameter	Symbol	Spec.			Unit
		min	typ	max	
Slave mode SCL clock frequency	f_{SCLS}	0		400	kHz
SCL clock low time	t_{LOW}	1200			ns
SCL clock high time	t_{HIGH}	600			ns
SDA output delay time	t_{AA}	100		900	ns
SDA data output hold time	t_{DH}	100			ns
Start condition setup time	$t_{SU,STA}$	600			ns
Start condition hold time	$t_{HD,STA}$	600			ns
Data in setup time	$t_{SU,DAT}$	100			ns
Data in hold time	$t_{HD,DAT}$	0			ns
Stop condition setup time	$t_{SU,STO}$	600			ns
SCL SDA rise time	t_R			300	ns
SCL SDA fall time	t_F			300	ns
Bus release time	t_{BUF}	1200			ns
Noise suppression time	t_{SP}			50	ns
Write time	t_{WC}			5	ms

Standard (100 kHz)

Parameter	Symbol	Spec.			Unit
		min	typ	max	
Slave mode SCL clock frequency	f_{SCLS}	0		100	kHz
SCL clock low time	t_{LOW}	4700			ns
SCL clock high time	t_{HIGH}	4000			ns
SDA output delay time	t_{AA}	100		3500	ns
SDA data output hold time	t_{DH}	100			ns
Start condition setup time	$t_{SU,STA}$	4700			ns
Start condition hold time	$t_{HD,STA}$	4000			ns
Data in setup time	$t_{SU,DAT}$	250			ns
Data in hold time	$t_{HD,DAT}$	0			ns
Stop condition setup time	$t_{SU,STO}$	4000			ns
SCL SDA rise time	t_R			1000	ns
SCL SDA fall time	t_F			300	ns
Bus release time	t_{BUF}	4700			ns
Noise suppression time	t_{SP}			50	ns
Write time	t_{WC}			5	ms

AC measurement condition

Input pulse level	$0.2 \times V_{CC}$ to $0.8 \times V_{CC}$
Input pulse rise / fall time	20 ns
Output timing reference level	$0.5 \times V_{CC}$
Output load	100 pF

Package Dimensions

unit : mm

WLCSP6, 0.80x1.20

CASE 567HM

ISSUE O

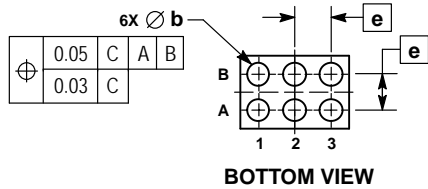
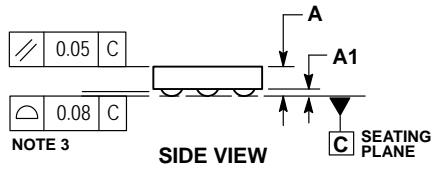
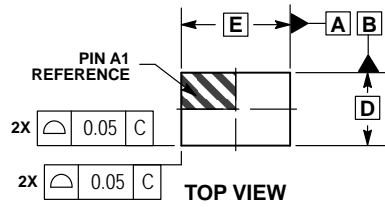

NOTES:

1. DIMENSIONING AND TOLERANCING PER ASME Y14.5M, 1994.
2. CONTROLLING DIMENSION: MILLIMETERS.
3. COPLANARITY APPLIES TO SPHERICAL CROWNS OF SOLDER BALLS.

DIM	MILLIMETERS	
	MIN	MAX
A	---	0.33
A1	0.03	0.13
b	0.15	0.25
D	0.80 BSC	
E	1.20 BSC	
e	0.40 BSC	

RECOMMENDED SOLDERING FOOTPRINT*

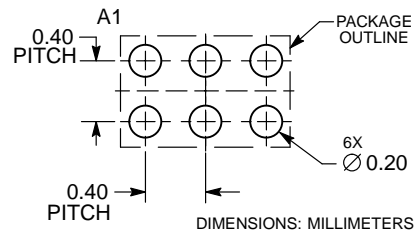

*For additional information on our Pb-Free strategy and soldering details, please download the ON Semiconductor Soldering and Mounting Techniques Reference Manual, SOLDERRM/D.

Pin Assignment

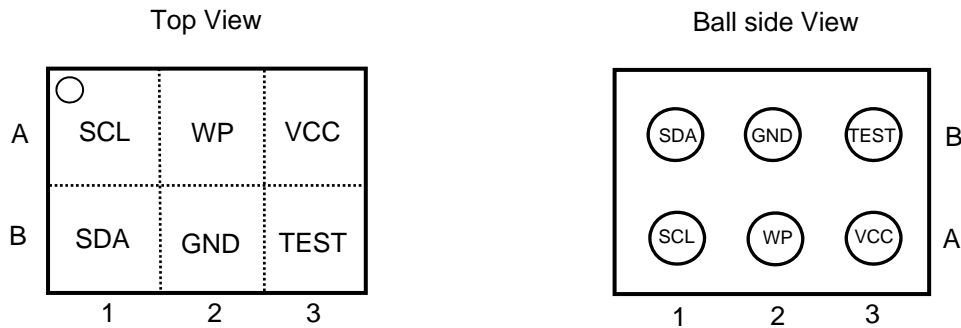

Pin Descriptions

A1	SCL	Serial clock input
A2	WP	Write protect
A3	VCC	Power supply
B1	SDA	Serial data in/output
B2	GND	Ground
B3	TEST	Slave Device Address 2

Block Diagram

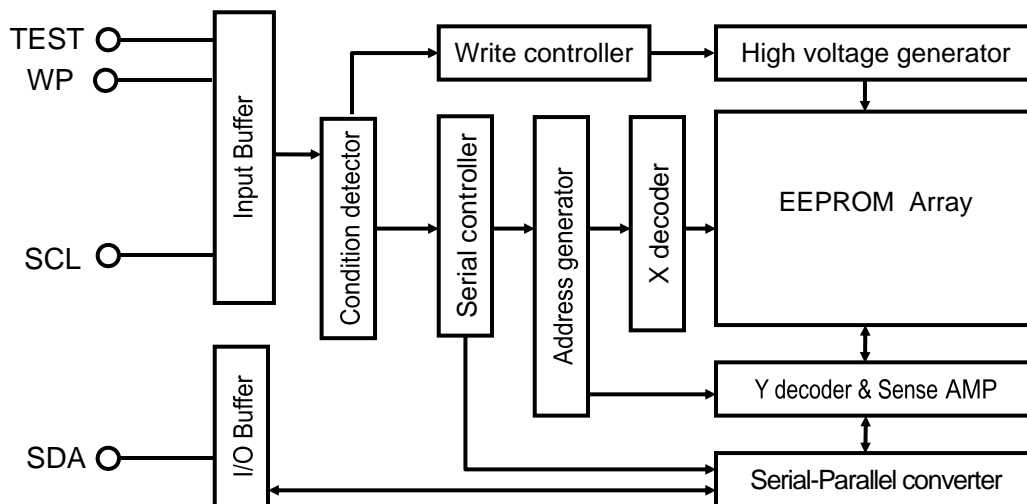

Bus timing

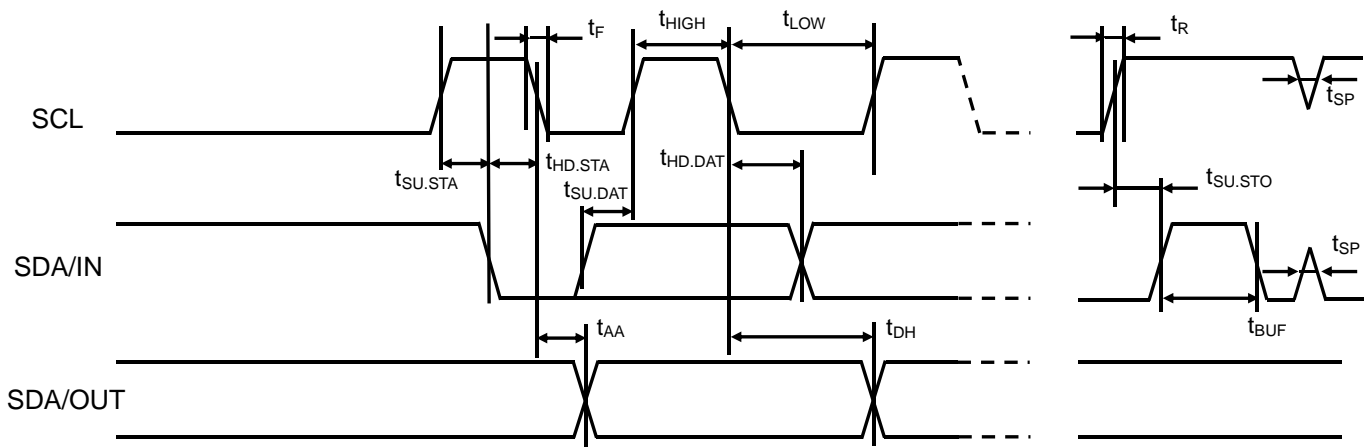

Write timing

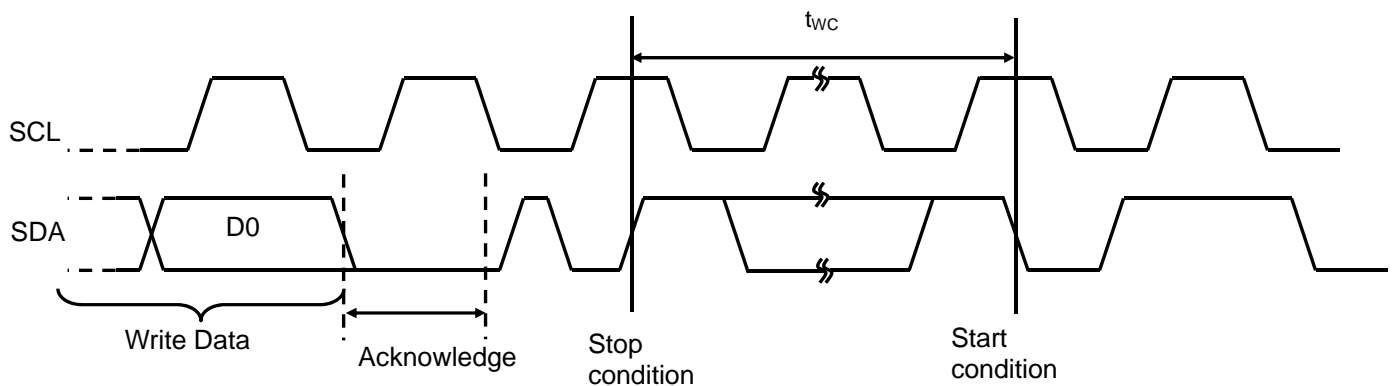

Pin Function

SCL (Serial clock)

The SCL signal is used to control serial input data timing. The SCL is used to latch input data synchronously at the rising edge and read output data synchronously at the falling edge.

SDA (Serial input / output data)

The SDA pin is bidirectional for serial data transfer. It is an open-drain structure that needs to be pulled up by resistor.

TEST (Slave address)

TEST pin represents S2. TEST pulled high (1.8 V) results in 7bit device address of 0x54. TEST pulled low results in 7 bit device address of 0x50.

The TEST must be tied to V_{CC} or GND.

WP (Write protect)

When the WP input is high, write protection is enabled. When WP input is either low or floating, write protection is disabled. The read operation is always activated irrespective of the WP pin status.

Functional Description

The device supports the I²C protocol. Any device that sends data on to the bus is defined to be a transmitter, and any device that reads the data to a receiver. The device that controls the data transfer is known as the bus master, and the other as the slave device.

1) Start Condition

A Start condition needs to start the EEPROM operation, it is to set falling edge of the SDA while the SCL is stable in the high status.

2) Stop Condition

A Stop condition is identified by rising edge of the SDA signal while the SCL is stable in the high status. The device becomes the standby mode from a Read operation by a Stop condition. In a write sequence, a stop condition is trigger to terminate the write data inputs and it is trigger to start the internal write cycle. After the internally write cycle time which is specified as t_{WC} , the device enters a standby mode.

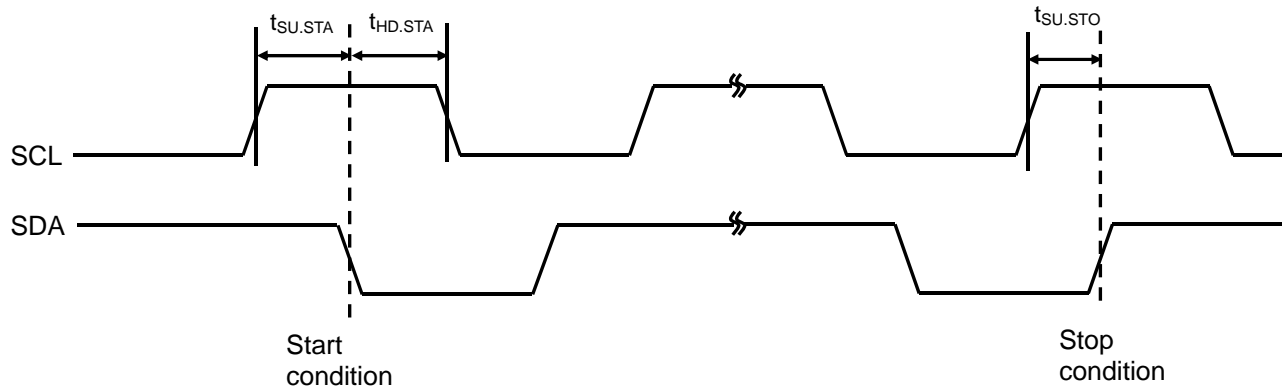

3) Data Input

During data input, the device latches the SDA on the rising edge of the SCL. For correct the operation, The SDA must be stable during the rising edge of the SCL.

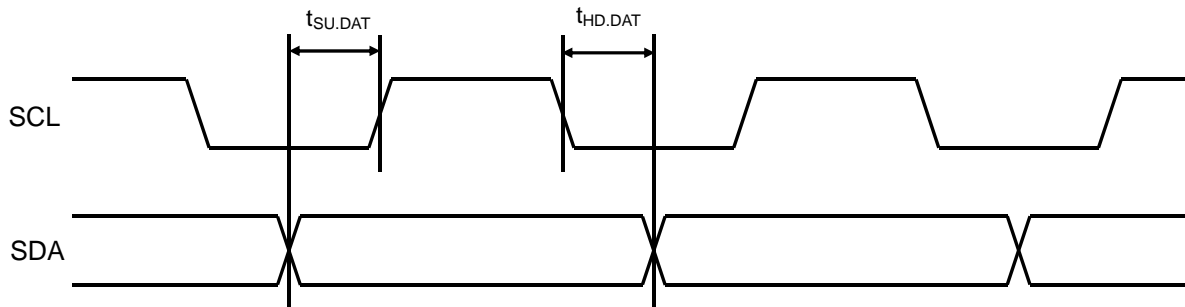

4) Acknowledge Bit (ACK)

The Acknowledge Bit is used to indicate a successful byte data transfer. The receiver sends a zero to acknowledge that it has received each word (Device Code, Slave Address etc) from the transmitter.

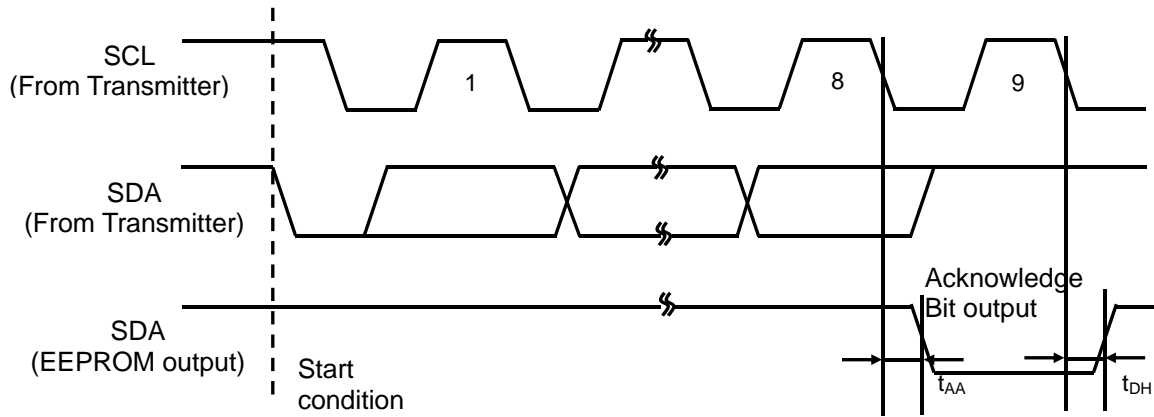

5) Device addressing

To transmit between the bus master and slave device (EEPROM), the master must send a Start condition to the EEPROM. The device address word of the EEPROM consists of 4-bit Device Code, 3-bit Memory address and 1-bit read/write code. By sending these, it becomes possible to communicate between the bus master and the EEPROM.

The upper 4-bit of the device address word are called the Device Code, the Device Code of the EEPROM uses 1010b fixed code. This device does not have the Slave address.

When the Device Code and Memory address (A10, A9, A8) are received on the SDA, the device only responds. The 8th bit is the read/write bit. The bit is set to 1 for Read operation and 0 for Write operation. If a match occurs on the Device Code, the corresponding device gives an acknowledgement on SDA during the 9th bit time. If device does not match the Device Code, it deselects itself from the bus, and goes into the Standby mode.

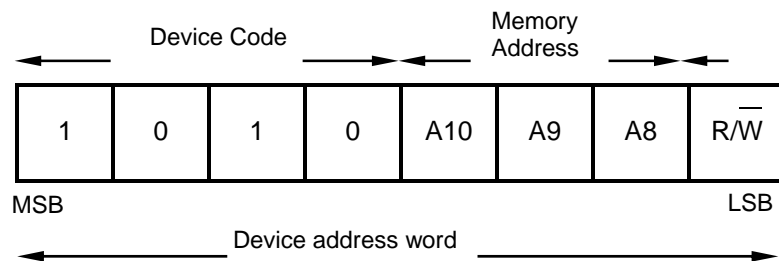

6) EEPROM Write Operation

6)-1. Byte Write

The write operation requires a 7-bit device address (Device code + A10 + A9 + A8) with the 8th bit = 0 (write). Then the EEPROM sends acknowledgement 0 at the 9th clock cycle. After these, the EEPROM receives word address (A7 to A0), and the EEPROM outputs acknowledgement 0. Then the EEPROM receives 8-bit write data, the EEPROM outputs acknowledgement 0 after receipt of write data. If the EEPROM receives a stop condition, the EEPROM enters an internally timed (t_{WC}) write cycle and terminates receipt of inputs until completion of the write cycle.

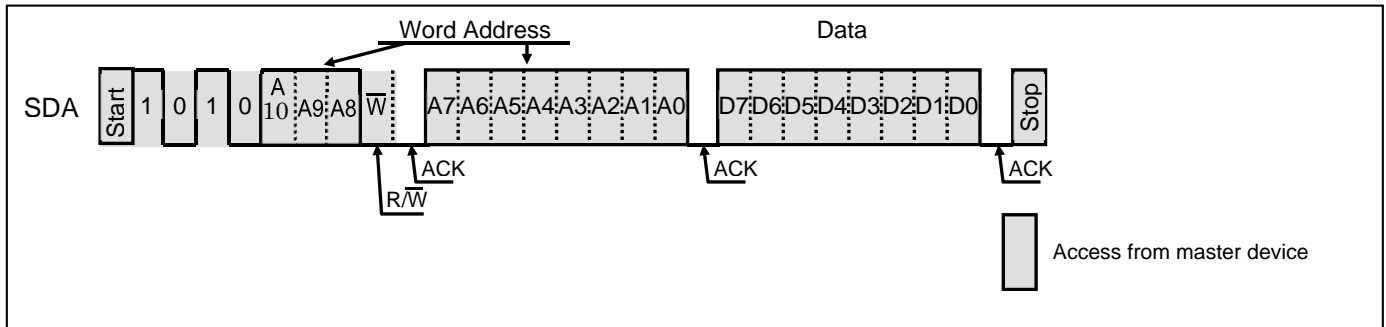

6)-2. Page Write

The Page write allows up to 16 bytes to be written in a single write cycle. The page write is the same sequence as the byte write except for inputting the more write data. The page write is initiated by a start condition, device code, memory address and write data(n) with every 9th bit acknowledgement. The device enters the page write operation if this device receives more write data(n+1) instead of receiving a stop condition. The page address (A0 to A3) bits are automatically incremented on receiving write data(n+1). The device can continue to receive write data up to 16 bytes. If the page address bits reaches the last address of the page, the page address bits will roll over to the first address of the same page and previous write data will be overwritten. After these, if the device receives a stop condition, the device enters an internally timed (t_{WC} × (n+x)) write cycle and terminates receipt of inputs until completion of the write cycle.

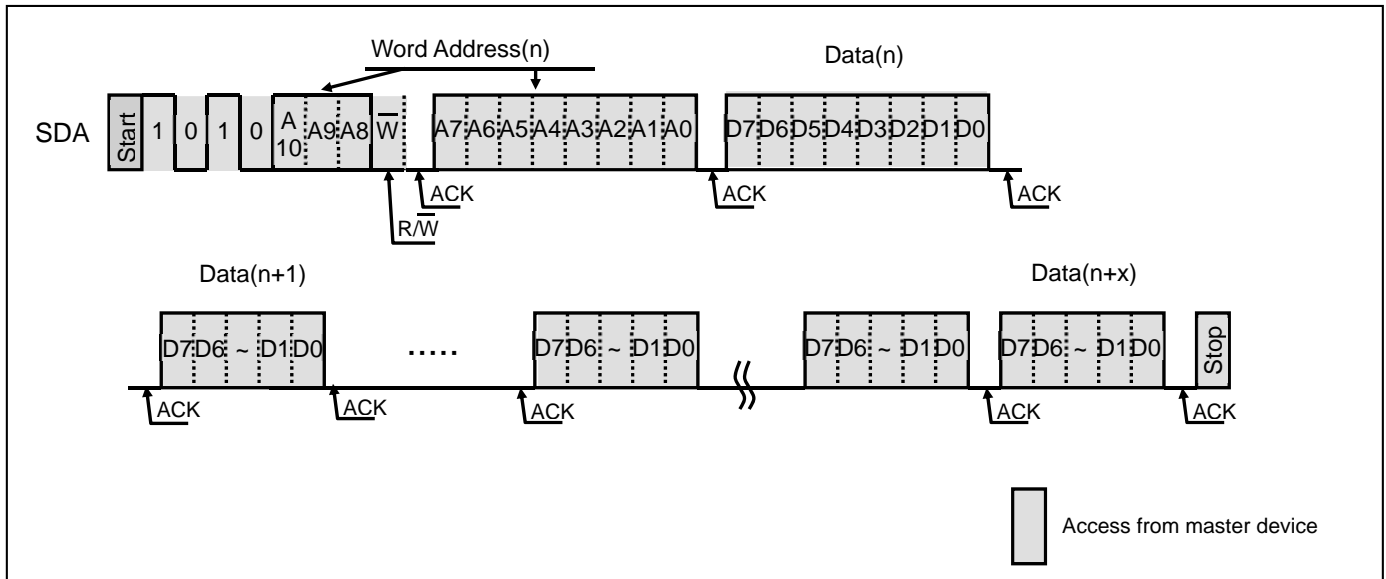

6)-3. Acknowledge Polling

The Acknowledge Polling operation is used to show if the EEPROM is in an internally timed write cycle or not. This operation is initiated by the stop condition after inputting write data. This requires the 8-bit device address word with the 8th bit = 0 (write) following the start condition during an internally timed write cycle. If the EEPROM is busy with the internal write cycle, no acknowledge will be returned. If the EEPROM has terminated the internal write cycle, it responds with an acknowledge. The terminated write cycle of the EEPROM can be known by this operation.

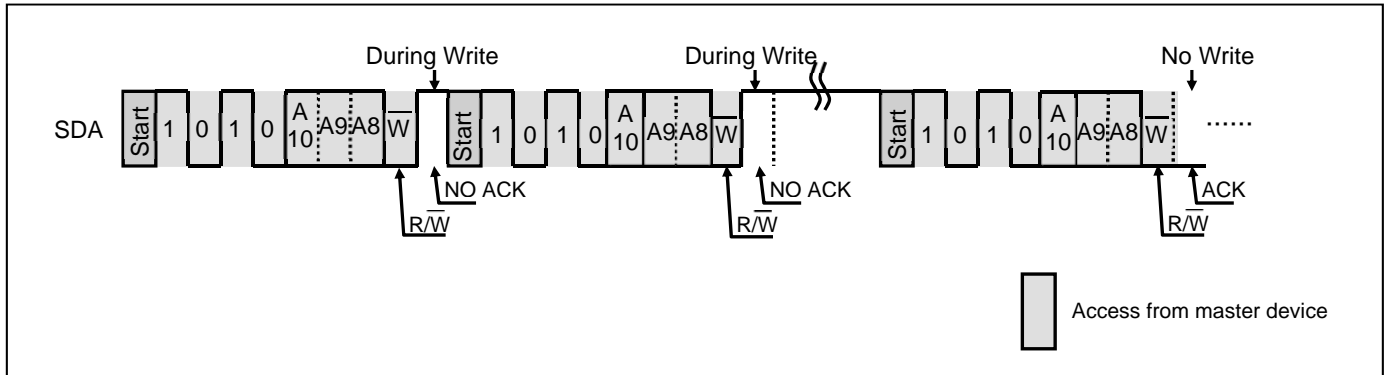

7) EEPROM Read Operation

7)-1. Current Address Read

The device has an internal address counter. It maintains that last address during the last read or write operation, with incremented by one. The current address read accesses the address kept by the internal address counter. After receiving a start condition and the device address word with the 8th bit = 1 (Read), the EEPROM outputs the 8-bit current address data from following acknowledgement 0. If the EEPROM receives acknowledgement 1 and a following stop condition, the EEPROM stops the read operation and is returned to a standby mode. In case the EEPROM has accessed the last address of the last page at previous read operation, the current address will roll over and returns to zero address. In case EEPROM has accessed the last address of the last page at previous write operation, the current address roll over within page addressing and returns to the first address in the same page.

The current address is valid while power is on. After power on, the current address will be reset (all 0).

Note: After the page write operation, the current address is the specified memory address in the last page write, if the write data is more than 16-bytes.

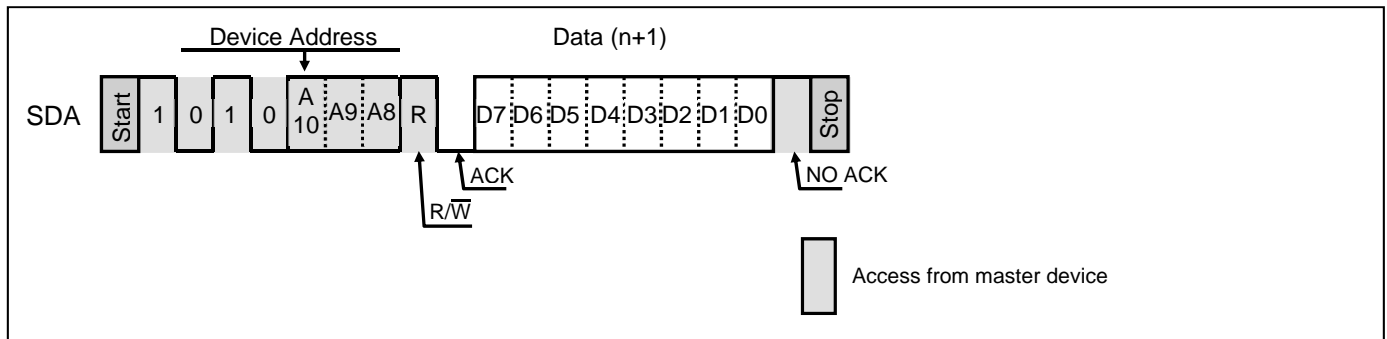

7)-2. Random Read

The random read requires a dummy write to set read address. The EEPROM receives a start condition and the device address (Device code + A10 + A9 + A8) with the 8th bit = 0 (write), the memory address. The EEPROM outputs acknowledgement 0 after receiving memory address then enters a current address read with receiving a start condition. The EEPROM outputs the read data of the address which was defined in the dummy write operation. After receiving no acknowledgement and a following stop condition, the EEPROM stops the random read operation and returns to a standby mode.

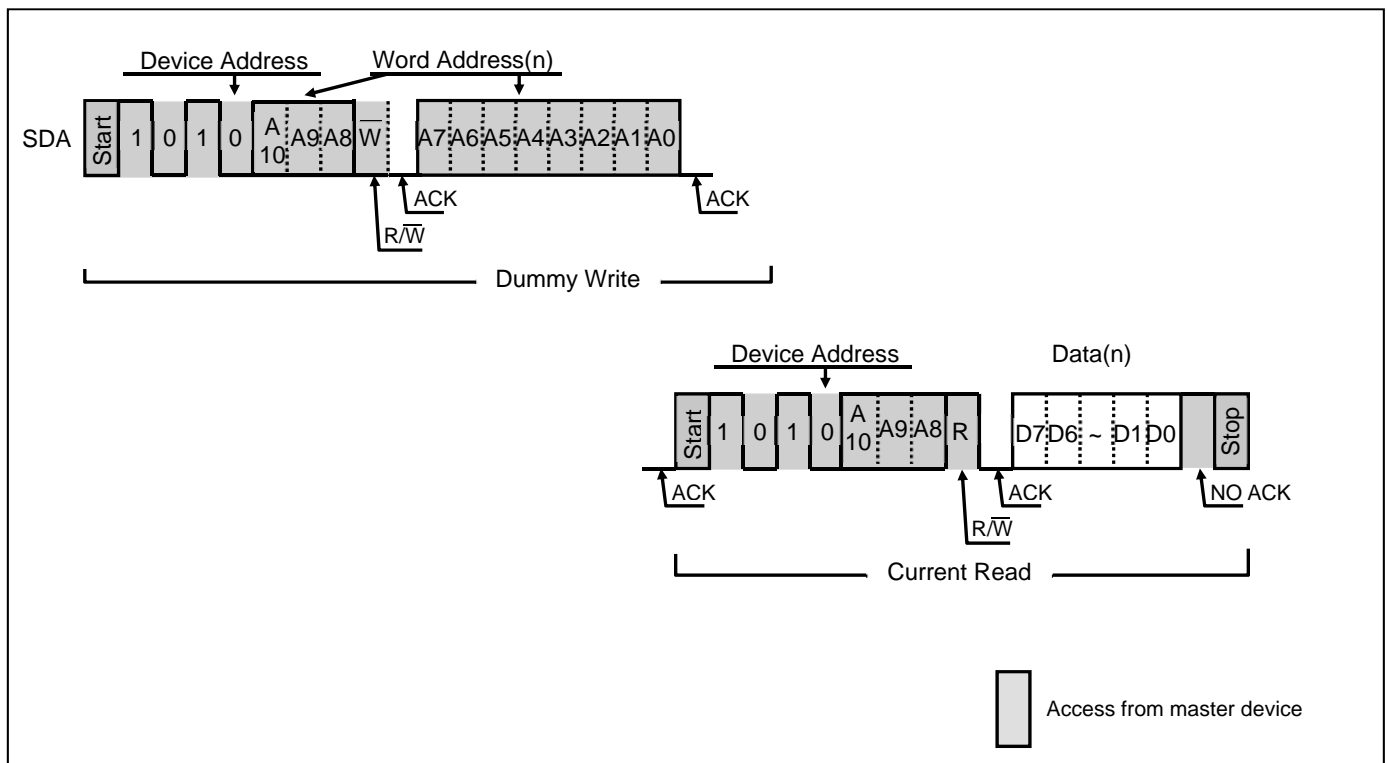

7)-3. Sequential Read

The sequential read operation is initiated by either a current address read or random read. If the EEPROM receives acknowledgement 0 after 8-bit read data, the read address is incremented and the next 8-bit read data outputs. The current address will roll over and returns address zero if it reaches the last address of the last page. The sequential read can be continued after roll over. The sequential read is terminated if the EEPROM receives no acknowledgement and a following stop condition.

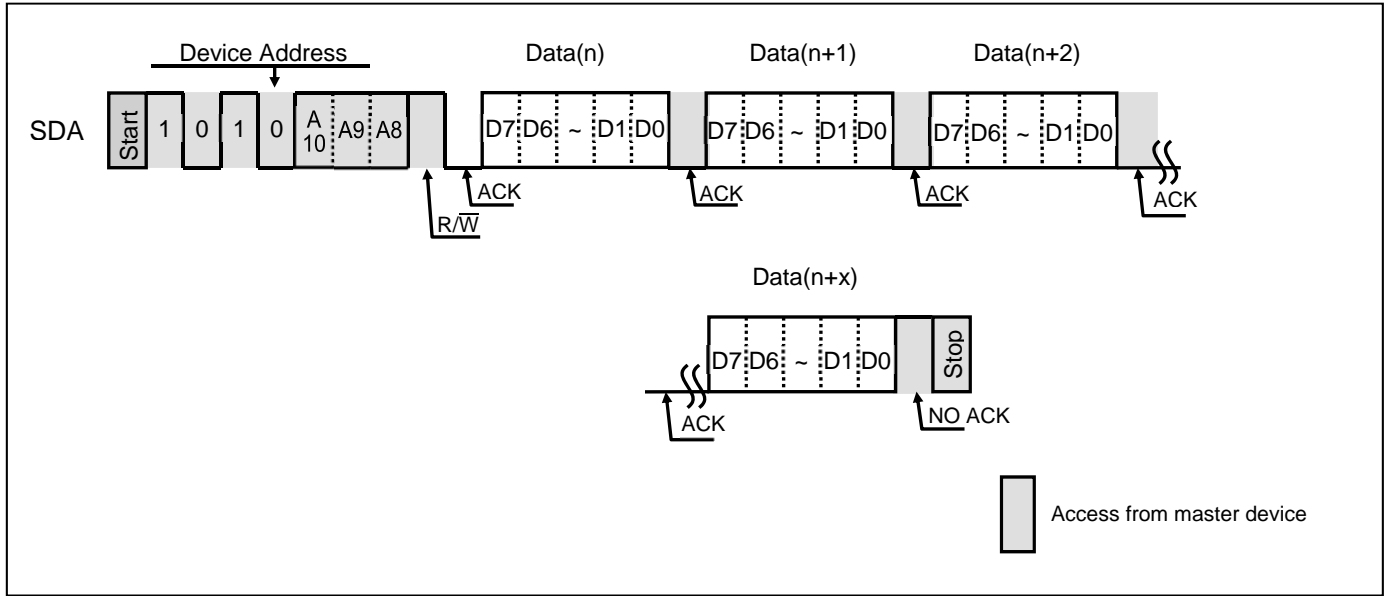

1) Software reset function

Software reset (start condition + 9 dummy clock cycles + start condition), shown in the figure below, is executed in order to avoid erroneous operation after power-on and to reset while the command input sequence. During the dummy clock input period, the SDA bus must be opened (set to high by a pull-up resistor). Since it is possible for the ACK output and read data to be output from the EEPROM during the dummy clock period, forcibly entering H will result in an overcurrent flow.

Note that this software reset function does not work during the internal write cycle.

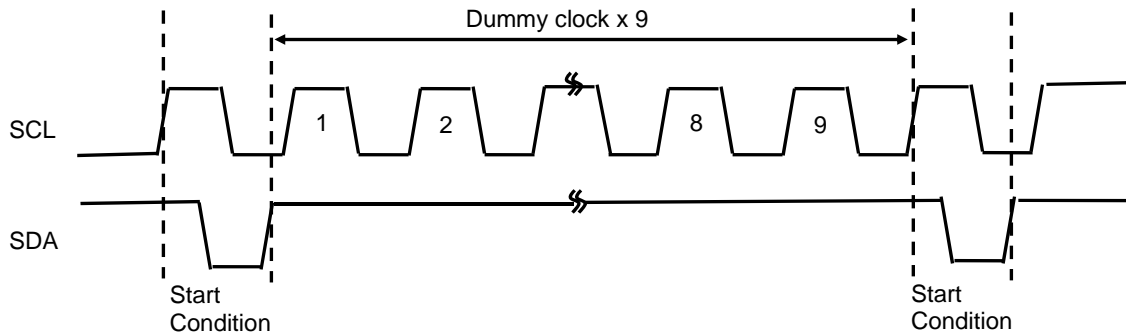

2) Pull-up resistor of SDA pin

Due to the demands of the I²C bus protocol function, the SDA pin must be connected to a pull-up resistor (with a resistance from several kΩ to several tens of kΩ) without fail. The appropriate value must be selected for this resistance (R_{PU}) on the basis of the V_{IL} and I_{IL} of the microcontroller and other devices controlling this product as well as the $V_{OL} - I_{OL}$ characteristics of the product. Generally, when the resistance is too high, the operating frequency will be restricted; conversely, when it is too low, the operating current consumption will increase.

R_{PU} maximum value

The maximum resistance must be set in such a way that the bus potential, which is determined by the sum total (I_L) of the input leaks of the devices connected to the SDA bus and by R_{PU} , can completely satisfy the input high level (V_{IH} min) of the microcontroller and EEPROM. However, a resistance value that satisfies SDA rise time tR and fall time tF must be set.

$$R_{PU} \text{ maximum value} = (V_{CC} - V_{IH}) / I_L$$

Example: When $V_{CC} = 3.0 \text{ V}$ and $I_L = 2 \mu\text{A}$

$$R_{PU} \text{ maximum value} = (3.0 \text{ V} - 3.0 \text{ V} \times 0.8) / 2 \mu\text{A} = 300 \text{ k}\Omega$$

R_{PU} minimum value

A resistance corresponding to the low-level output voltage (V_{OL} max) of EEPROM must be set.

$$R_{PU} \text{ minimum value} = (V_{CC} - V_{OL}) / I_{OL}$$

Example: When $V_{CC} = 3.0 \text{ V}$, $V_{OL} = 0.4 \text{ V}$ and $I_{OL} = 1 \text{ mA}$

$$R_{PU} \text{ minimum value} = (3.0 \text{ V} - 0.4) / 1 \text{ mA} = 2.6 \text{ k}\Omega$$

Recommended R_{PU} setting

R_{PU} is set to strike a good balance between the operating frequency requirements and power consumption. If it is assumed that the SDA load capacitance is 50 pF and the SDA output data strobe time is 500 ns, R_{PU} will be about $R_{PU} = 500 \text{ ns} / 50 \text{ pF} = 10 \text{ k}\Omega$.

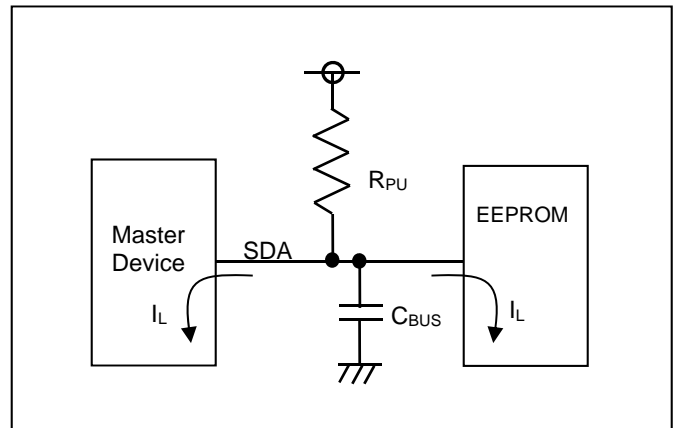

3) Precautions when turning on the power

This product contains a power-on reset circuit for preventing the inadvertent writing of data when the power is turned on. The following conditions must be met in order to ensure stable operation of this circuit. No data guarantees are given in the event of an instantaneous power failure during the internal write operation.

symbol	Parameter	Spec.			Unit
		Min.	Typ.	Max.	
t_{RISE}	Power rise time	–	–	100	ms
t_{OFF}	Power off time	10	–	–	ms
V_{bot}	Power bottom voltage	–	–	0.2	V

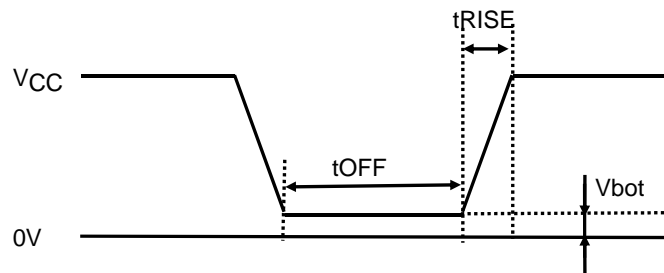

Notes:

- 1) The SDA pin must be set to high and the SCL pin to low or high.
- 2) Steps must be taken to ensure that the SDA and SCL pins are not placed in a high-impedance state.

A. If it is not possible to satisfy the instruction 1 in Note above, and SDA is set to low during power rise

After the power has stabilized, the SCL and SDA pins must be controlled as shown below, with both pins set to high.

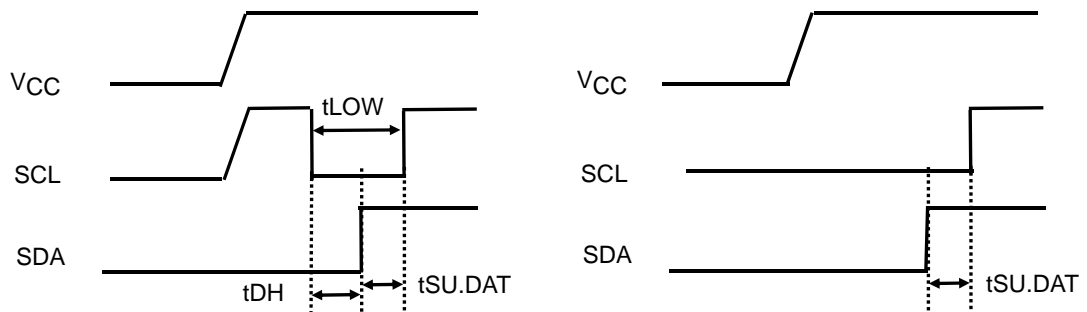

B. If it is not possible to satisfy the instruction 2 in Note above

After the power has stabilized, software reset must be executed.

C. If it is not possible to satisfy the instructions both 1 and 2 in Note above

After the power has stabilized, the steps in A must be executed, then software reset must be executed.

4) Noise filter for the SCL and SDA pins

This product contains a filter circuit for eliminating noise at the SCL and SDA pins. Pulses of 100 ns or less are not recognized because of this function.

5) Function to inhibit writing when supply voltage is low

This product contains a supply voltage monitoring circuit that inhibits inadvertent writing below the guaranteed operating supply voltage range. The data is protected by ensuring that write operations are not started at voltages (typ.) of 1.3 V and below.

6) Notes on write protect operation

This product prohibits all memory array writing when the WP pin is high. To ensure full write protection, the WP is set high for all periods from the start condition to the stop condition, and the conditions below must be satisfied.

symbol	Parameter	Spec.			Unit
		Min.	Typ.	Max.	
$t_{SU.WP}$	WP Setup time	600	–	–	ns
$t_{HD.WP}$	WP Hold time	600	–	–	ns

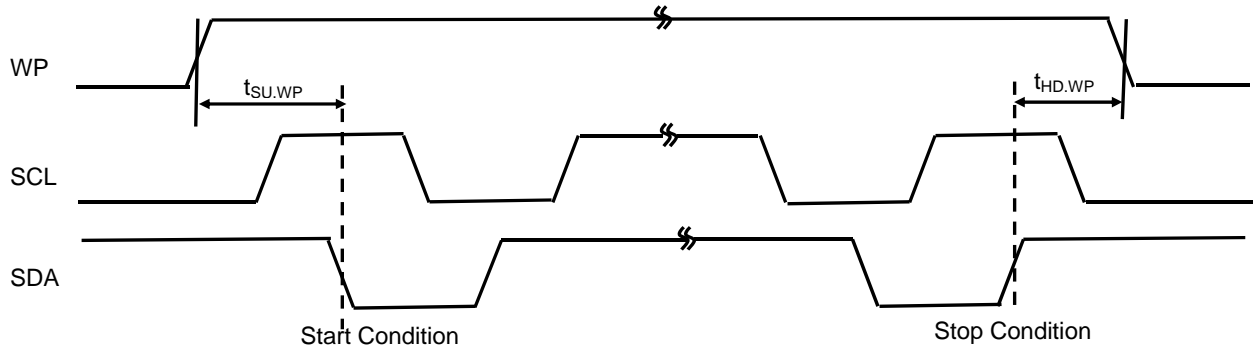

MARKING INFORMATION

LE2416DXA WLP6(0.80x1.20)

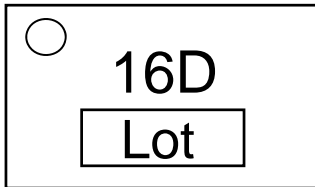

Part ID : 16D
Lot Number : 3digits

ORDERING INFORMATION

Device	Package	Shipping (Qty / Packing)
LE2416DXATBG	WLCSP6, 0.80x1.20 (Pb-Free / Halogen Free)	5000 / Tape & Reel

† For information on tape and reel specifications, including part orientation and tape sizes, please refer to our Tape and Reel Packaging Specifications Brochure, BRD8011/D. http://www.onsemi.com/pub_link/Collateral/BRD8011-D.PDF

* I²C Bus is a trademark of Philips Corporation.

ON Semiconductor and the ON Semiconductor logo are trademarks of Semiconductor Components Industries, LLC dba ON Semiconductor or its subsidiaries in the United States and/or other countries. ON Semiconductor owns the rights to a number of patents, trademarks, copyrights, trade secrets, and other intellectual property. A listing of ON Semiconductor's product/patent coverage may be accessed at www.onsemi.com/site/pdf/Patent-Marking.pdf. ON Semiconductor reserves the right to make changes without further notice to any products herein. ON Semiconductor makes no warranty, representation or guarantee regarding the suitability of its products for any particular purpose, nor does ON Semiconductor assume any liability arising out of the application or use of any product or circuit, and specifically disclaims any and all liability, including without limitation special, consequential or incidental damages. Buyer is responsible for its products and applications using ON Semiconductor products, including compliance with all laws, regulations and safety requirements or standards, regardless of any support or applications information provided by ON Semiconductor. "Typical" parameters which may be provided in ON Semiconductor data sheets and/or specifications can and do vary in different applications and actual performance may vary over time. All operating parameters, including "Typicals" must be validated for each customer application by customer's technical experts. ON Semiconductor does not convey any license under its patent rights nor the rights of others. ON Semiconductor products are not designed, intended, or authorized for use as a critical component in life support systems or any FDA Class 3 medical devices or medical devices with a same or similar classification in a foreign jurisdiction or any devices intended for implantation in the human body. Should Buyer purchase or use ON Semiconductor products for any such unintended or unauthorized application, Buyer shall indemnify and hold ON Semiconductor and its officers, employees, subsidiaries, affiliates, and distributors harmless against all claims, costs, damages, and expenses, and reasonable attorney fees arising out of, directly or indirectly, any claim of personal injury or death associated with such unintended or unauthorized use, even if such claim alleges that ON Semiconductor was negligent regarding the design or manufacture of the part. ON Semiconductor is an Equal Opportunity/Affirmative Action Employer. This literature is subject to all applicable copyright laws and is not for resale in any manner.