

VENTURE GA3219

Pre-configured DSP System for Hearing Aids

Description

VENTURE GA3219 combines the power capabilities of an advanced platform with advanced research, delivering cutting-edge features and high performance.

This hardware platform is ON Semiconductor's industry-leading programmable digital signal processing platform. Adaptive Algorithms is a methodology developed by ON Semiconductor that couples state-of-the-art acoustic algorithms to ensure high-fidelity digital sound quality.

Venture GA3219's adaptive noise reduction preserves perceived speech levels without causing distortion. It monitors noise levels independently in 128 individual bands. This strategy also employs advanced psychoacoustic models to eliminate audible noise and reduce the amount of perceptible artifacts introduced by the noise reduction process.

Based on a phase cancellation method, Venture GA3219's adaptive feedback reduction algorithm provides increased maximum stable gain unlike other feedback strategies. Additionally, it features rapid adjustment for dynamic feedback situations and resistance to tonal inputs.

In addition to these adaptive algorithms, Venture GA3219 also supports the following features: Frontwave[®] directional processing, cross fading between audio paths for click-free memory changes, 8-band graphic equalizer, 8 generic biquad filters (configurable as parametric or other filter types), programming speed enhancements, optional peak clipping, flexible compression adjustments, programmable tones for memory change and low battery indicators, wideband gain, volume control and industry-leading security features to avoid cloning and software piracy.

Features

- Adaptive Algorithms:
 - ◆ 128-band Adaptive Noise Reduction
 - ◆ Adaptive Feedback Cancellation
- 128-bit Fingerprint Security System and Other Security Features to Protect Against Device Cloning and Software Piracy
- Soft Acoustic Fade Between Memory Changes
- FrontWave Directional Processing
- High Fidelity Audio CODEC
- 20-bit Audio Precision
- 95 dB Input Dynamic Range with HRX™ Headroom Extension
- 1, 2 or 4 Channel WDRG Compression
- 8-Band Graphic EQ
- Eight Biquadratic Filters
- Drives Zero-Bias 2-Terminal Receivers
- Four Analog Inputs
- Two Memory Select Pads



ON Semiconductor[®]

www.onsemi.com

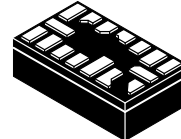

16 PAD
HYBRID
CASE TBD

PAD CONNECTION

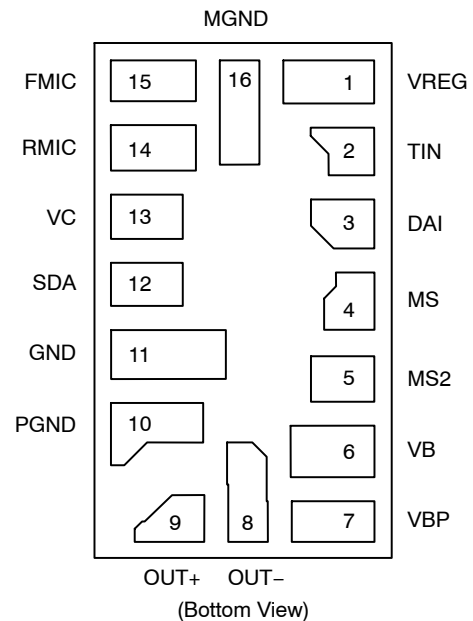

MARKING DIAGRAM

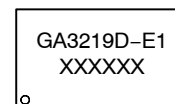

GA3219D = Specific Device Code
E1 = RoHS Compliant Hybrid
XXXXXX = Work Order Number

ORDERING INFORMATION

See detailed ordering and shipping information on page 12 of this data sheet.

VENTURE GA3219

Features

- Four Fully Configurable Memories with Audible Memory Change Indicator
- Internal or External Volume Control with Programmable Range
- AGC-O with Variable Threshold, Time Constants, and Optional Adaptive Release
- 16 kHz or 8 kHz Bandwidth

- Optimized Programming Speed
- thinSTAX® Packaging
- E1 RoHS Compliant Hybrid

thinSTAX Packaging

- Hybrid Typical Dimensions:
0.215 x 0.124 x 0.065 in.
(5.46 x 3.15 x 1.65 mm)

BLOCK DIAGRAM

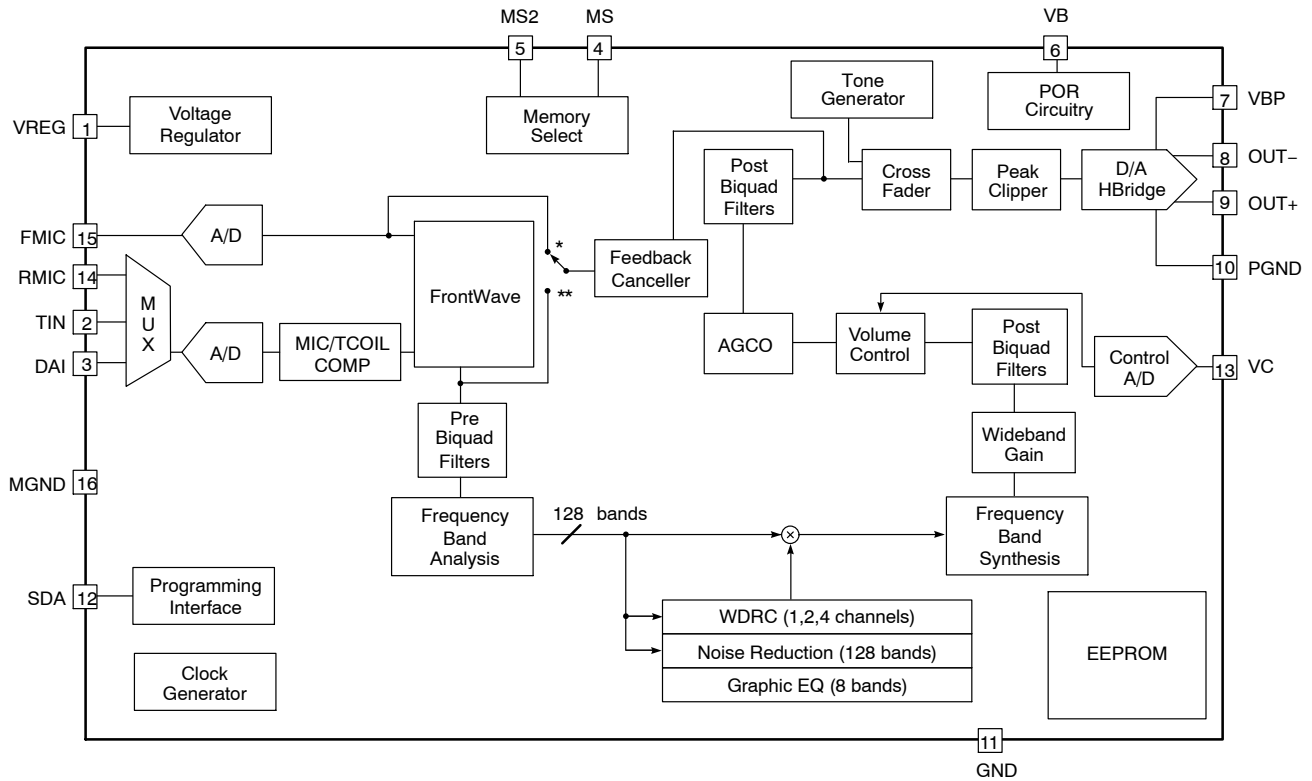

* If Input Mode = 1 mic omni, Mic + Telecoil or Mic + DAI

** If Input Mode = rear only, 2 mic omni, FrontWave or ADM

Figure 1. Hybrid Block Diagram

VENTURE GA3219

Table 1. ABSOLUTE MAXIMUM RATINGS

Parameter	Value	Units
Operating Temperature Range	0 to +40	°C
Storage Temperature Range	-20 to +70	°C
Absolute Maximum Power Dissipation	25	mW
Maximum Operating Supply Voltage	1.5	VDC
Absolute Maximum Supply Voltage	2	VDC

Stresses exceeding those listed in the Maximum Ratings table may damage the device. If any of these limits are exceeded, device functionality should not be assumed, damage may occur and reliability may be affected.

WARNING: Electrostatic Sensitive Device – Do not open packages or handle except at a static-free workstation.

WARNING: Moisture Sensitive Device – Non-RoHS Compliant – Level 3 MSL; RoHS Compliant – Level 4 MSL. Do not open packages except under controlled conditions.

Table 2. ELECTRICAL CHARACTERISTICS ($V_{BAT} = 1.25\text{ V}$; Temperature = 25°C)

Parameter	Symbol	Conditions	Min	Typ	Max	Units
Hybrid Current	I_{AMP}	With adaptive features 8 kHz bandwidth	-	770	-	μA
		With adaptive features 16 kHz bandwidth	-	990	-	
		No adaptive feature 8 kHz bandwidth	-	720	-	
		No adaptive feature 16 kHz bandwidth	695	835	975	
Minimum Operating Supply Voltage	V_{BOFF}	Ramp down	0.93	0.95	0.97	V
Supply Voltage Turn On Threshold	V_{BON}	Ramp up	1.06	1.1	1.16	V
EEPROM Burn Cycles	-	-	100 k	-	-	cycles
Low Frequency System Bandwidth	-	-	-	125	-	Hz
High Frequency System Bandwidth	-	32 kHz sampling rate	-	16	-	kHz
Total Maximum System Gain	A_V	$V_{IN} = -95\text{ dBV}$ at 1 kHz (Note 1)	83	84	85	dB
Converter Gain	A_{Conv}	A / D + D / A gain	29	30	31	dB
Total Harmonic Distortion	THD	$V_{IN} = -40\text{ dBV}$	-	-	1	%
THD at Maximum Input	THD _M	$V_{IN} = -15\text{ dBV}$, HRX – ON	-	-	3	%
Clock Frequency	f_{clk}	-	1.945	2.048	2.151	MHz

REGULATOR

Regulator Voltage	V_{REG}	-	0.87	0.90	0.93	V
-------------------	-----------	---	------	------	------	---

INPUT

Input Referred Noise	IRN	Bandwidth 100 Hz – 8 kHz	-	-108	-106	dBV
Input Impedance	Z_{IN}	-	-	16	-	k Ω
Anti-aliasing Filter Rejection	-	$f = f_{CLK} - 8\text{ kHz}$, $V_{IN} = -40\text{ dBV}$	-	80	-	dB
Maximum Input Level	-	-	-	-15	-	dBV
Input Dynamic Range	-	HRX – ON Bandwidth 100 Hz – 8 kHz	-	93	-	dB

Product parametric performance is indicated in the Electrical Characteristics for the listed test conditions, unless otherwise noted. Product performance may not be indicated by the Electrical Characteristics if operated under different conditions.

1. Total system gain consists of: wideband system gain + channel gain + converter gain. Total system gain is calibrated during Cal/Config process.

VENTURE GA3219

Table 2. ELECTRICAL CHARACTERISTICS ($V_{BAT} = 1.25\text{ V}$; Temperature = 25°C)

Parameter	Symbol	Conditions	Min	Typ	Max	Units
OUTPUT						
D/A Dynamic Range	-	-	-	88	-	dB
Output Impedance	Z_{OUT}	-	-	-	15	Ω
VOLUME CONTROL						
Volume Control Resistance	R_{VC}	Two-terminal connection	160	200	240	k Ω
		Three-terminal connection	100	-	1000	
Volume Control Range	ΔA	-	1	-	42	dB
SDA INPUT						
Logic 0 Voltage	-	-	0	-	0.3	V
Logic 1 Voltage	-	-	1	-	1.3	V
SDA OUTPUT						
Standby Pull Up Current	-	-	1.4	5	6.5	μA
Sync Pull Up Current	-	-	775	900	1100	μA
Logic 0 Current (Pull Down)	-	-	-	450	-	μA
Logic 1 Current (Pull Up)	-	-	-	450	-	μA
Synchronization Time (Synchronization Pulse Width)	T_{SYNC}	Baud = 0	237	250	263	μs
		Baud = 1	118	125	132	
		Baud = 2	59	62.5	66	
		Baud = 3	29.76	31.25	32.81	
		Baud = 4	14.88	15.63	16.41	
		Baud = 5	7.44	7.81	8.20	
		Baud = 6	3.72	3.91	4.10	
		Baud = 7	1.86	1.95	2.05	
MS AND MS2 INPUTS						
Pull Down / Up Resistance	-	-	-	1	-	M Ω
Logic 1 Voltage	-	-	V_{REG}	-	V_B	V
Rising Edge Threshold	-	-	0.5	0.69	0.9	V
Falling Edge Threshold	-	-	0.25	0.45	0.5	V
Hysteresis	-	-	0.1	0.24	0.4	V

Product parametric performance is indicated in the Electrical Characteristics for the listed test conditions, unless otherwise noted. Product performance may not be indicated by the Electrical Characteristics if operated under different conditions.

1. Total system gain consists of: wideband system gain + channel gain + converter gain. Total system gain is calibrated during Cal/Config process.

VENTURE GA3219

TYPICAL APPLICATIONS

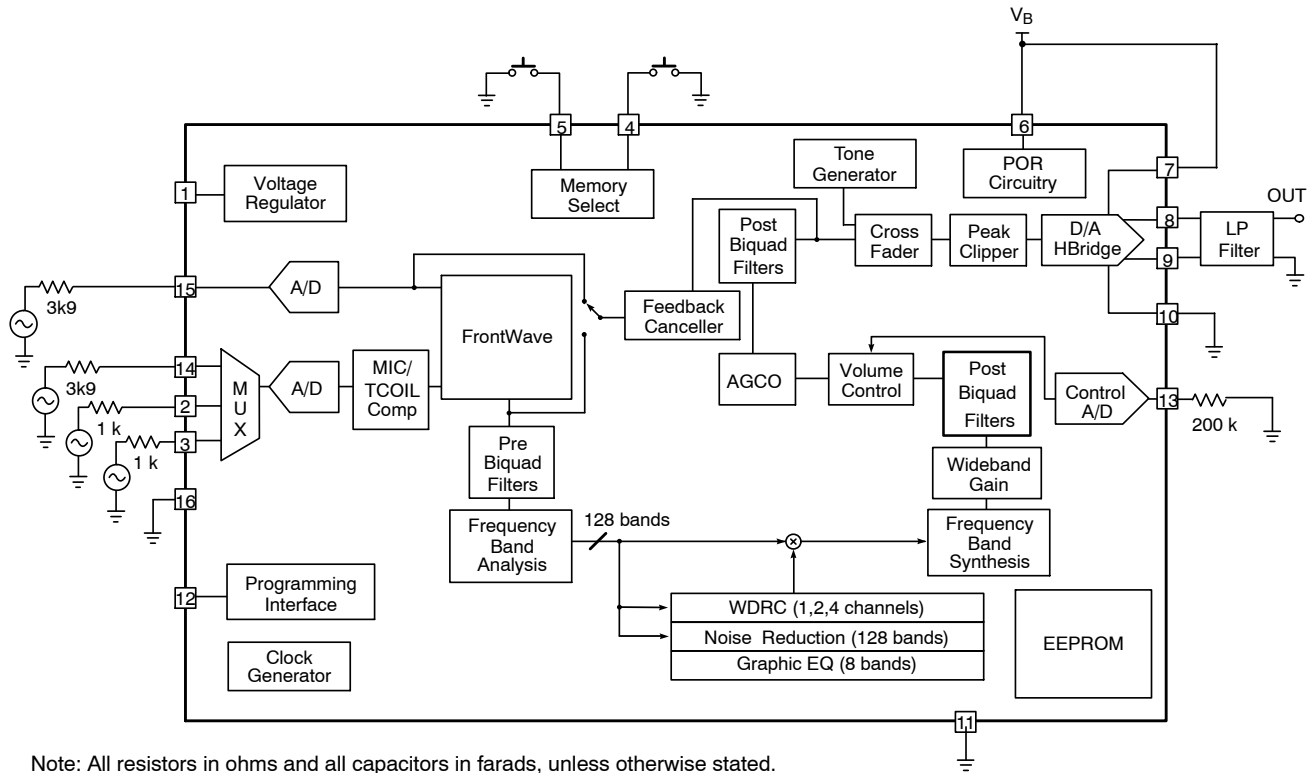

Figure 2. Test Circuit

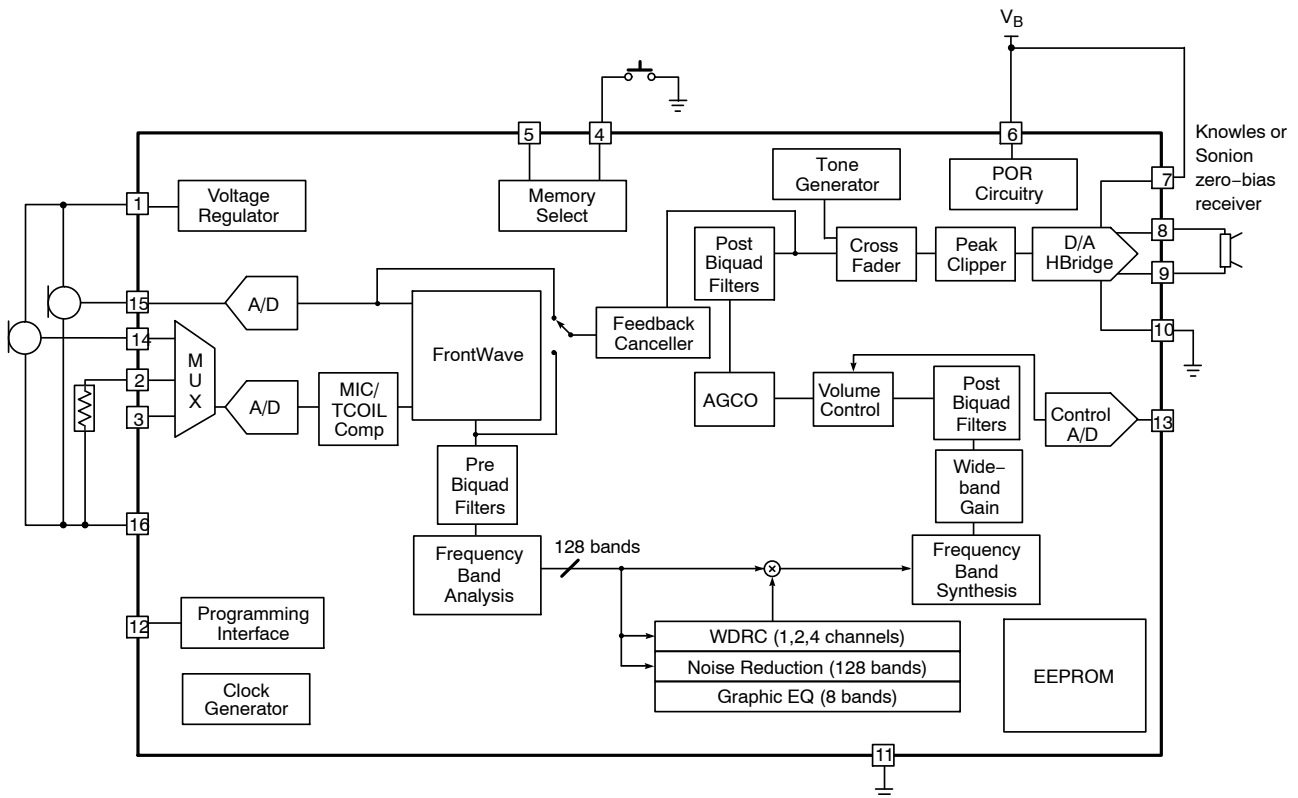

Figure 3. Typical Application Circuit

VENTURE GA3219

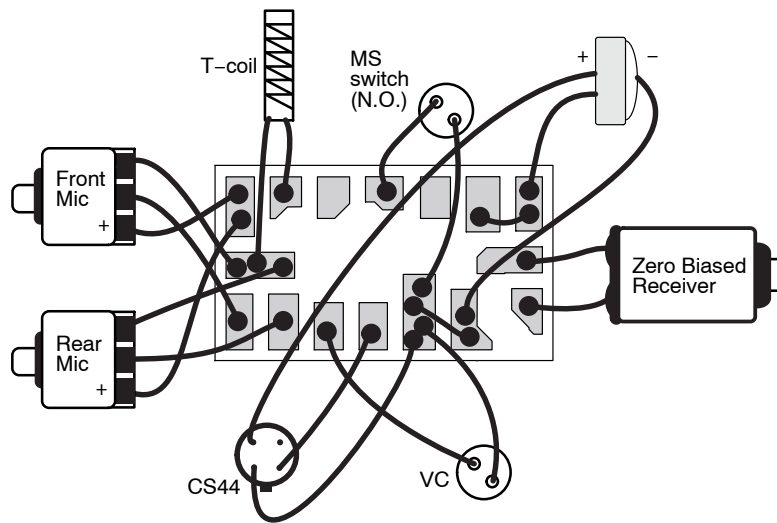

Figure 4. Typical Hearing Instrument Assembly Diagram

VENTURE GA3219 OVERVIEW

Venture GA3219 is a DSP system with adaptive algorithms that run on an advanced hardware platform. This hardware platform is a combination of a DSP core and a high fidelity audio CODEC. As well, thinSTAX packaging provides easy integration into a wide range of applications from CIC to BTE.

The audio functions implemented on the CODEC include tone generation, peak clipping and cross fading between audio paths. The DSP core implements Frontwave directional processing, programmable filters, adaptive algorithms, compression, wideband gain, and volume control. The adaptive algorithms include Adaptive Noise Reduction and Adaptive Feedback Cancellation.

The Adaptive Noise Reduction reduces audible noise in a low distortion manner while preserving perceived speech levels. The Adaptive Feedback Canceller reduces acoustic feedback while offering robust performance against pure tones. As well, Venture GA3219 contains security features to protect clients' Intellectual Property against device cloning and software piracy.

Venture GA3219 utilizes the power and capabilities of the hardware platform to deliver advanced features and enhanced performance previously unavailable to a product in its class.

This data sheet is part of a documentation set available for this product.

SIGNAL PATH

There are two main audio input signal paths. The first path contains the front microphone and the second path contains the rear microphone, telecoil or direct audio input as selected by a programmable MUX. The front microphone input is intended as the main microphone audio input for single microphone applications. In FrontWave operation, a multi-microphone signal is used to produce a directional hearing instrument response. The two audio inputs are buffered, sampled and converted into digital form using dual A/D converters. The digital outputs are converted into a 32 kHz or 16 kHz, 20-bit digital audio signal.

Further IIR filter blocks process the front microphone and rear microphone signals. One biquad filter is used to match the rear microphone's gain to that of the front microphone. After that, other filtering is used to provide an adjustable group delay to create the desired polar response pattern during the calibration process.

In the Telecoil mode gains are trimmed during Cal/Config process to compensate for microphone/telecoil mismatches.

The FrontWave block is followed by four cascaded biquad filters: *pre1*, *pre2*, *pre3* and *pre4*. These filters can be used for frequency response shaping before the signal goes through channel and adaptive processing.

The channel and adaptive processing consists of the following:

- Frequency band analysis
- 1, 2 or 4 channel WDRC
- Eight logarithmically spaced band frequency shaping (graphic EQ)
- 128 frequency band adaptive noise reduction
- Frequency band synthesis
- Phase cancellation adaptive feedback reduction

After the processing the signal goes through two more biquad filters, *post1* and *post2*, the Wideband Gain and Volume Control.

These biquad filters are followed by the AGC-O block, two more biquad filters, *post3* and *post4*, and the Peak Clipper. The last stage in the signal path is the D/A H-bridge.

FUNCTIONAL BLOCK DESCRIPTION

Adaptive Feedback Canceller

The Adaptive Feedback Canceller (AFC) reduces acoustic feedback by forming an estimate of the hearing aid feedback signal and then subtracting this estimate from the hearing aid input. Therefore, the forward path of the hearing aid is not affected. Unlike adaptive notch filter approaches, the Venture GA3219’s AFC does not reduce the hearing aid’s gain. The AFC is based on a time-domain model of the feedback path.

The third-generation AFC (see Figure 5) allows for an increase in the stable gain1 of the hearing instrument while minimizing artefacts for music and tonal input signals. As with previous products, the feedback canceller provides completely automatic operation.

(Added stable gain will vary based on hearing aid style and acoustic setup. Please refer to the Adaptive Feedback Cancellation Information note for more details.)

When the AFC is enabled, it is highly recommended that you either have all channels with Squelch ON or all channels with Squelch OFF. If you choose to have all channels with Squelch ON, then there is an additional requirement to have all Squelch thresholds above the microphone noise floor. If you require any assistance in determining what threshold levels to set, please contact the applications department at ON Semiconductor. Squelch ON/OFF does not incur any current penalty. When Squelch and AFC are both ON, the Squelch is limited to 1:2 expansion.

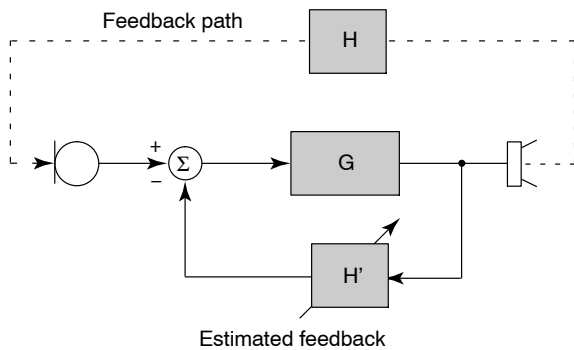

Figure 5. Adaptive Feedback Canceller (AFC) Block Diagram

Adaptive Noise Reduction

The noise reduction algorithm is built upon a high resolution 128-band filter bank enabling precise removal of noise. The algorithm monitors the signal and noise activities in these bands, and imposes a carefully calculated attenuation gain independently in each of the 128 bands.

The noise reduction gain applied to a given band is determined by a combination of three factors:

- Signal-to-Noise Ratio (SNR)
- Masking threshold
- Dynamics of the SNR per band

The SNR in each band determines the maximum amount of attenuation to be applied to the band – the poorer the SNR, the greater the amount of attenuation. Simultaneously, in each band, the masking threshold variations resulting from the energy in other adjacent bands is taken into account. Finally, the noise reduction gain is also adjusted to take advantage of the natural masking of ‘noisy’ bands by speech bands over time.

Based on this approach, only enough attenuation is applied to bring the energy in each ‘noisy’ band to just below the masking threshold. This prevents excessive amounts of attenuation from being applied and thereby reduces unwanted artifacts and audio distortion. The Noise Reduction algorithm efficiently removes a wide variety of types of noise, while retaining natural speech quality and level.

A/D and D/A Converters

The system’s two A/D converters are second order sigma-delta modulators operating at a 2.048 MHz sample rate. The system’s two audio inputs are pre-conditioned with antialias filtering and programmable gain pre-amplifiers. These analog outputs are over-sampled and modulated to produce two, 1-bit Pulse Density Modulated (PDM) data streams. The digital PDM data is then decimated down to Pulse-Code Modulated (PCM) digital words at the system sampling rate of 32 kHz.

The D/A is comprised of a digital, third order sigma-delta modulator and an H-bridge. The modulator accepts PCM audio data from the DSP path and converts it into a 32-times over-sampled, 1-bit PDM data stream, which is then supplied to the H-bridge. The H-bridge is a specialized CMOS output driver used to convert the 1-bit data stream into a low-impedance, differential output voltage waveform suitable for driving zero-biased hearing aid receivers.

HRX Head Room Expander

The Venture GA3219 has an enhanced Head Room Expander (HRX) circuit that increases the input dynamic range of Venture GA3219 without any audible artifacts. This is accomplished by dynamically adjusting the pre-amplifier’s gain and the post-A/D attenuation depending on the input level.

FrontWave Directionality

The FrontWave block provides the resources necessary to implement directional microphone processing. The block accepts inputs from front and rear microphones and provides a synthesized directional microphone signal as its output. The directional microphone output is obtained by delaying the rear microphone signal and subtracting it from the front microphone signal. Various microphone response patterns can be obtained by adjusting the time delay.

The FrontWave circuit also provides a fixed filter for compensating the sensitivity and frequency response differences between microphones. The filter parameters are adjusted during product calibration.

A dedicated biquad filter following the FrontWave block has been allocated for low frequency equalization to compensate for the 6 dB/octave roll-off in frequency response that occurs in directional mode. The amount of low frequency equalization that is applied can be determined during product calibration.

ON Semiconductor recommends using matched microphones with FrontWave.

Channel Processing

Figure 6 represents the I/O characteristic of independent AGC channel processing. The I/O curve can be divided into the following main regions:

- Low input level expansion (squelch) region
- Low input level linear region
- Compression region
- High input level linear region (return to linear)

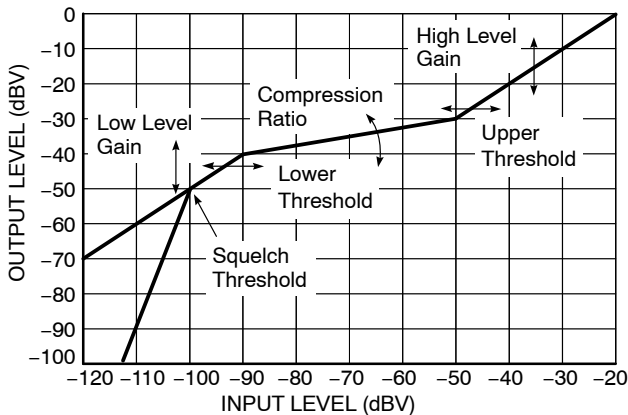

Figure 6. Independent Channel I/O Curve Flexibility

The I/O characteristic of the channel processing can be adjusted in the following ways:

- Squelch threshold (SQUELCHTH)
- Low level gain (LLGAIN)
- Lower threshold (LTH)
- High level gain (HLGAIN)
- Upper threshold (UTH)
- Compression ratio (CR)

To ensure that the I/O characteristics are continuous, it is necessary to limit adjustment to a maximum of four of the available five parameters. During Parameter Map creation, it is necessary to select four parameters as user adjustable, or fixed, and to allow one parameter to be calculated.

The squelch region within each channel implements a low level noise reduction scheme (1:2 or 1:3 expansion ratio) for listener comfort. This scheme operates in quiet listening environments (programmable threshold) to reduce the gain at very low levels. When the Squelch and AFC are both enabled, it is highly recommended that the Squelch be turned ON in all channels and that the Squelch thresholds be set above the microphone noise floor. For details, refer to the AFC description.

The number of compression channels is programmable in ARKonline® and can be 1, 2 or 4.

Telecoil Path

The telecoil input is calibrated during the Cal/Config process. To compensate for the telecoil/microphone frequency response mismatch, a first order filter with 500 Hz corner frequency is implemented. Through ARKonline, it is possible to implement a telecoil compensation filter with an adjustable corner frequency. To accommodate for the gain mismatch, the telecoil gain is adjusted to match the microphone gain at 500 Hz or 1 kHz (default) and is selectable in ARKonline.

There is also a telecoil gain adjustment parameter that can be enabled in ARKonline and set in IDS, enabling manual adjustment of the telecoil gain compensation.

Graphic Equalizer

Venture GA3219 has an 8 band graphic equalizer. The bands are spaced logarithmically, and each one provides up to 24 dB of gain adjustment in 1 dB increments.

Biquad Filters

Additional frequency shaping can be achieved by configuring generic biquad filters. The transfer function for each of the biquad filters is as follows:

$$H(z) = \frac{b_0 + b_1 \times z^{-1} + b_2 \times z^{-2}}{1 + a_1 \times z^{-1} + a_2 \times z^{-2}}$$

Note that the a0 coefficient is hard-wired to always be '1'. The coefficients are each 16 bits in length and include one sign bit, one bit to the left of the decimal point, and 14 bits to the right of the decimal point. Thus, before quantization, the floating-point coefficients must be in the range $-2.0 \leq x < 2.0$ and quantized with the function:

$$\text{round}(x \times 2^{14})$$

After designing a filter, the quantized coefficients can be entered into the PreBiquads or PostBiquads tab in the Interactive Data Sheet. The coefficients b0, b1, b2, a1, and a2 are as defined in the transfer function above. The parameters meta0 and meta1 do not have any effect on the

signal processing, but can be used to store additional information related to the associated biquad.

The underlying code in the product components automatically checks all of the filters in the system for stability (i.e., the poles have to be within the unit circle) before updating the graphs on the screen or programming the coefficients into the hybrid. If the Interactive Data Sheet receives an exception from the underlying stability checking code, it automatically disables the biquad being modified and display a warning message. When the filter is made stable again, it can be re-enabled.

Also note that in some configurations, some of these filters may be used by the product component for microphone/telecoil compensation, low-frequency EQ, etc. If this is the case, the coefficients entered by the user into IDS are ignored and the filter designed by the software is programmed instead. For more information on filter design refer to the Biquad Filters In PARAGON® Digital Hybrid information note.

Volume Control

The Volume Control (VC) can be either external or programmable. If VC is programmed for external operation, a variable resistor should be connected to the 9 bit A/D converter.

The external VC can be configured to work with either a two-terminal 200 k Ω variable resistor or a three-terminal 0.1 M Ω – 1 M Ω variable resistor. In two-terminal configuration, the VC is connected between GND, Vreg and the VC input.

If using a two-terminal VC, it must be calibrated before use. Calibration is not necessary with a three-terminal connection. Hysteresis is built into the VC circuitry to prevent unintentional volume level toggling. A log taper potentiometer is recommended so that gain in dB would be linear with potentiometer rotation. The range of VC is adjustable and can be set between 1 dB (min) and 42 dB (max).

AGC-O and Peak Clipper

The output compression-limiting block (AGC-O) is an output limiting circuit whose compression ratio is fixed at $\infty:1$. The threshold level is programmable. The AGC-O module has programmable attack and release time constants.

The AGC-O on Venture GA3219 has optional adaptive release functionality. When this function is enabled, the release time varies depending on the environment. In general terms, the release time becomes faster in environments where the average level is well below the threshold and only brief intermittent transients exceed the threshold.

Conversely, in environments where the average level is close to the AGC-O threshold, the release time applied to portions of the signal exceeding the threshold is longer. The result is an effective low distortion output limiter that clamps

down very quickly on momentary transients but reacts more smoothly in loud environments to minimize compression pumping artifacts. The programmed release time is the longest release time applied, while the fastest release time is 16 times faster. For example, if a release time of 128 ms is selected, the fastest release time applied by the AGC-O block is 8 ms.

Venture GA3219 also includes the Peak Clipper block for added flexibility.

Memory Select Switches

One or two, two-pole Memory Select (MS) switches can be used with Venture GA3219. This enables users tremendous flexibility in switching between configurations. These switches may be either momentary or static and are configurable to be either pull-up or pull-down through the settings tab in IDS.

Up to four memories can be configured on Venture GA3219. Memory A must always be valid. All memory select options are selectable via the settings tab in IDS.

Momentary Switch on MS

This mode uses a single momentary switch on MS (Pin4) to change memories. Using this mode causes the part to start in memory A, and whenever the button is pressed, the next valid memory is loaded. When the user is in the last valid memory, a button press causes memory A to be loaded.

This mode is set by programming the 'MSSMode' parameter to 'Momentary' and 'Only' to 'disabled'.

Example:

- If 4 valid memories: ABCDABCD...A...
- If 3 valid memories: ABCABCA...A...
- If 2 valid memories: ABABA...A...
- If 1 valid memories: AAA...A...

Momentary Switch on MS, Static Switch on MS2 (Jump to Last Memory)

This mode uses a static switch on MS2 (Pin5) and a momentary switch on MS (Pin4) to change memories. If the static switch is OPEN, the part starts in memory A and behaves like momentary, with the exception that memory D is not used. If the static switch on MS2 is set to HIGH, the part automatically jumps to memory D (occurs on start-up or during normal operation). In this setup, the momentary switch's state is ignored, preventing memory select beeps from occurring. When MS2 is set to OPEN, the part loads in the last select memory.

This mode is set by programming the 'MSSMode' parameter to 'Momentary' and 'Only' to 'enabled'.

Example:

- If MS2 = OPEN and there are 4 valid memories: ABCABCA...A...
- If MS2 = OPEN and there are 3 valid memories: ABABA...A...
- If MS2 = HIGH: D...A...

VENTURE GA3219

Table 3. DYNAMIC EXAMPLE WITH FOUR VALID MEMORIES (T = momentary switch is toggled; 0 = OPEN; 1 = HIGH)

MS2	0	0	0	1	1	1	0	0	0	1	0	0	0	0	0	0
MS	0	T	T	0	T	T	0	T	T	0	0	T	T	T	T	T
Memory	A	B	C	D	D	D	C	A	B	D	B	C	A	B	C	A

Static Switch on MS and MS2

This mode uses two static switches to change memories. Table 4 describes which memory is selected depending on the state of the switches.

In this mode, it is possible to jump from any memory to any other memory simply by changing the state of both switches. If both switches are changed simultaneously, then the transition is smooth. Otherwise, if one switch is changed and then the other, the part transitions to an intermediate memory before reaching the final memory. The part starts in whatever memory the switches are selecting. If a memory is invalid, the part defaults to memory A.

This mode is set by programming the 'MSSMode' parameter to 'static' and 'Only' to 'disabled'.

Table 4. MEMORY SELECTED IN STATIC SWITCH ON MS and MS2 MODE; Internal Resistors Set to Pull Down

MS	MS2	Memory
OPEN	OPEN	A
HIGH	OPEN	B (if valid, otherwise A)
OPEN	HIGH	C (if valid, otherwise A)
HIGH	HIGH	D (if valid, otherwise A)

Static Switch on MS, Static Switch on MS2 (Jump to Last Memory)

This mode uses two static switches to change memories. Unlike in the previous example, this mode will switch to the last valid memory when the static switch on MS2 is HIGH. This means that this mode will only use a maximum of three memories (even if four valid memories are programmed). Table 5 describes which memory is selected depending on the state of the switches.

This mode is set by programming the 'MSSMode' parameter to 'static' and 'Only' to 'enabled'.

Table 5. MEMORY SELECTED IN STATIC SWITCH ON MS, Static Switch on MS2 (Jump to Last Memory) Mode; Internal Resistors Set to Pull Down

MS	MS2	Memory
OPEN	OPEN	A
HIGH	OPEN	B (if valid, otherwise A)
OPEN	HIGH	D
HIGH	HIGH	D

In this mode, it is possible to jump from any memory to any other memory simply by changing the state of both

switches. If both switches are changed simultaneously, then the transition is smooth. Otherwise, if one switch is changed and then the other, the part transitions to an intermediate memory before reaching the final memory.

When MS2 is set HIGH, the state of the switch on MS is ignored. This prevents memory select beeps from occurring if switching MS when MS2 is HIGH.

The part starts in whatever memory the switches are selecting. If a memory is invalid, the part defaults to memory A.

Audible Memory Change Indicator

Venture GA3219 can be programmed to produce tones to indicate a memory change. Using the Interactive Data Sheet, Venture GA3219 can be configured to either enable or disable the Memory Change Indicator.

When the Memory Change Indicator is enabled, there is an option to have a single beep for each memory change or to have multiple beeps.

The amplitude and frequency of the memory change tone can be selected independently from the Tone Generator settings and can be individually selected for each memory. When the memory change multiple beep is enabled, and the memory change tone is enabled, then during a memory change operation the selected tone beeps a code to indicate which memory was selected. The beep sequence is 160 ms ON, followed by 160 ms OFF, between the beeps. The memory change beeping code is deciphered in Table 6.

Table 6. MEMORY CHANGE BEEPING CODE

Selected Memory	# Beeps
A	1
B	2
C	3
D	4

Tone Generator

The programmable tone generator is capable of tones of various amplitudes and frequencies. Upon reception of the tone enable instruction, Venture GA3219 connects the output of the tone generator to the input of the D/A converter. The programmed tone is then output until a tone disable instruction is issued. When disabled, the normal audio signal is again connected.

Memory Switch Fader

To minimize potential loud transients when switching between memories, Venture GA3219 uses a memory switch fader block. When the memory is changed, the audio signal is faded out, followed by the memory select indicator beeps

(if enabled), and after switching to the next memory, the audio signal is faded back in. The memory switch fader is also used when turning the Tone Generator on or off, and during SDA programming.

Power-On/Power-Off Behaviour and Low Battery Indicator

During power-on, the Venture GA3219 hybrid is held in a reset state until the supply voltage (V_b) reaches a turn-ON threshold. A small portion of the hybrid's internal control logic turns on and monitors the voltage to determine if the supply is stable. Once the supply is stable, the entire hybrid is activated and loads its configuration. Finally, the audio output turns on by smoothly transitioning to the expected output level.

During normal operation, when a low battery condition is detected, the Venture GA3219 hybrid sends out a series of one to seven beeps (each beep is 512 ms ON and 512 ms OFF) to indicate the battery is low. This is repeated every five minutes until the device reaches the turn-OFF threshold. The low battery threshold is programmable in IDS between 1.0 V and 1.2 V in 10 mV increments.

If V_b drops below the turn-OFF threshold, then the Venture GA3219 hybrid is returned to its reset state and the audio output is muted. After a reset due to a low battery or a sudden supply transient, the recovery behaviour of the Venture GA3219 is determined by the selectable reset mode through ARKonline.

There are four selectable reset modes as follows:

- **Shallow-reset mode** – After a low battery shutdown or transient shutdown, it allows the Venture GA3219 hybrid to immediately restart when the supply voltage rises above the turn-ON threshold. The device restarts in the memory that was last active when the shut down occurred. In summary, the device functions until the supply voltage drops below the turn-OFF threshold, and recovers when the device rises above the turn-ON threshold again.
- **Deep-reset mode** – After a low battery shutdown or transient shutdown, it does not allow the Venture GA3219 hybrid to restart. When a shutdown occurs (i.e., the supply voltage drops below the turn-OFF threshold), the device remains off until the supply voltage drops below approximately 0.3 V and subsequently rises above the turn-ON threshold. For the supply to drop below 0.3 V, the battery should be disconnected. Upon reconnecting the battery (preferably a new battery) the supply voltage rises above the turn-ON threshold, and depending if the supply is stable, the device restarts.
- **Mixed mode** – A combination of the first two modes. The device starts up in shallow-reset mode initially, then transitions to deep reset mode after five minutes.
- **Advanced reset mode** (recommended) – A more advanced combination of the first two modes, plus some additional intelligence. The device starts up in

shallow-reset mode initially, so that after a low battery shutdown or a transient shutdown, the device immediately restarts when the supply voltage rises above the turn-ON threshold. When the device restarts, deep-reset mode is applied and the device operates in the memory that was last active when the shut down occurred. Additionally, the maximum output level is reduced through a 2 dB reduction of the AGC-O and peak clipper. This operating condition is defined as transient reboot mode. The device operates in transient reboot mode (i.e., deep-reset mode and maximum output reduction are applied) while monitoring the supply voltage. If the supply voltage remains above the turn-ON threshold for at least 30 secs, the device is allowed to exit transient reboot mode. The device returns to shallow-reset mode and the maximum output is restored.

Generally, any low battery shutdown or transient shutdown that occurs while in shallow-reset mode (or while in the shallow-reset mode component of mixed mode or advanced reset mode) results in the Venture GA3219 hybrid restarting into the memory that was last active when the shut down occurred. The Venture GA3219 hybrid has this memory restart capability for up to three memories. A restart in any memory beyond the first three memories causes the device to restart in the initial memory, similar to the behaviour when a battery is first connected. The transient reboot mode described above also applies to up to three memories. Any additional memories would use the shallow-reset mode behaviour, and would restart in the initial memory after a shutdown.

In any of the above reset modes, the Venture GA3219 hybrid can be configured through ARKonline to reduce the gain as the battery voltage drops. When the supply voltage falls below the low battery threshold, low battery tones are emitted and the wideband gain is reduced by 3 dB. As the battery voltage continues to drop, the low battery tones continue and the wideband gain continues to be reduced. Once the turn-OFF threshold is reached, the device shuts down.

Software and Security

Venture GA3219 incorporates the following security features to protect the device from cloning and against software piracy:

- DLL protection by password – prevents a third party from using IDS to reconfigure parts.
- Hybrid authentication by 128-bit fingerprint to identify parts in application software – prevents a third party from cloning a device's EEPROM because the fingerprint cannot be overwritten. Special functions can be used in fitting software to reject parts that do not match the expected fingerprint. This would prevent the piracy of fitting software.
- DLL to hybrid pairing by using a software key in ARK to match product libraries with client software – a part

VENTURE GA3219

can be ‘locked’ at manufacturing time so that it only communicates with the library it was programmed with. This prevents a third party from potentially upgrading a device with a different library in IDS or other application software.

Full software support is provided for every stage of development from design to manufacturing to fitting. For details, refer to the Getting Started with the ARK Software information note.

SDA Communication

Venture GA3219 is programmed via the SDA pin using industry standard programming boxes. During parameter changes, the main audio signal path of the hybrid is temporarily muted using the memory switch fader to avoid the generation of disturbing audio transients. Once the changes are complete, the main audio path is reactivated. Any changes made during programming are lost at power-off unless they are explicitly burned to EEPROM memory.

Improvements have been made to the ARK software for Venture GA3219 resulting in increased communication speed. Certain parameters in ARKonline can be selected to reduce the number of pages that need to be read out.

Power Management

Venture GA3219 was designed to accommodate high power applications. AC ripple on the supply can cause instantaneous reduction of the battery’s voltage, potentially disrupting the circuit’s function. Venture GA3219 hybrids have a separate power supply and ground connections for the output stage. This enables hearing instrument designers to accommodate external RC filters to minimize any AC ripple from the supply line. Reducing this AC ripple greatly improves the stability of the circuit and prevents unwanted reset of the circuit caused by spikes on the supply line.

For more information on properly designing a filter to reduce supply ripple, refer to the Using DSP Hybrids in High Power Applications Initial Design Tips information note.

ORDERING INFORMATION

Device	Package	Shipping†
GA3219D-E1	16 Pad Hybrid	25 Units / Bubble Pack
GA3219D-E1-T	16 Pad Hybrid	500 Units / Tape & Reel

†For information on tape and reel specifications, including part orientation and tape sizes, please refer to our Tape and Reel Packaging Specifications Brochure, BRD8011/D.

Hybrid Jig Ordering Information

To order a Hybrid Jig Evaluation Board for Venture GA3219 contact your Sales Account Manager or FAE and use part number GA3280GEVB.

VENTURE GA3219

PAD LOCATION

Table 7. PAD POSITION AND DIMENSIONS

Pad No.	Pad Position		Pad Dimensions	
	X	Y	Xdim (mil)	Ydim (mil)
1	0	0	18	38
2	29	5.75	20	26.5
3	59.25	5.75	20.5	26.5
4	91.5	8.5	24	21
5	124	5.75	19	26.5
6	154.25	1.75	21.5	34.5
7	183.5	1.75	17	34.5
8	171.25	-33.75	41.5	16.5
9	182.25	-66.5	19.5	29
10	147	-71.5	26	39
11	113.75	-66.5	20.5	49
12	84.5	-76	18	30
13	56.25	-76	18.5	30
14	27.25	-73.25	18.5	35.5
15	-0.5	-73.25	17	35.5
16	12.75	-37.25	43.5	16.5
Pad No.	X	Y	Xdim (mm)	Ydim (mm)
1	0	0	0.457	0.965
2	0.737	0.146	0.508	0.673
3	1.505	0.146	0.521	0.673
4	2.324	0.216	0.610	0.533
5	3.150	0.146	0.483	0.673
6	3.918	0.044	0.546	0.876
7	4.661	0.044	0.432	0.876
8	4.350	-0.857	1.054	0.419
9	4.629	-1.689	0.495	0.737
10	3.734	-1.816	0.660	0.991
11	2.889	-1.689	0.521	1.245
12	2.146	-1.930	0.457	0.762
13	1.429	-1.930	0.470	0.762
14	0.692	-1.861	0.470	0.902
15	-0.013	-2.007	0.432	0.902
16	0.324	-0.946	1.105	0.419

VENTURE GA3219

PACKAGE DIMENSIONS

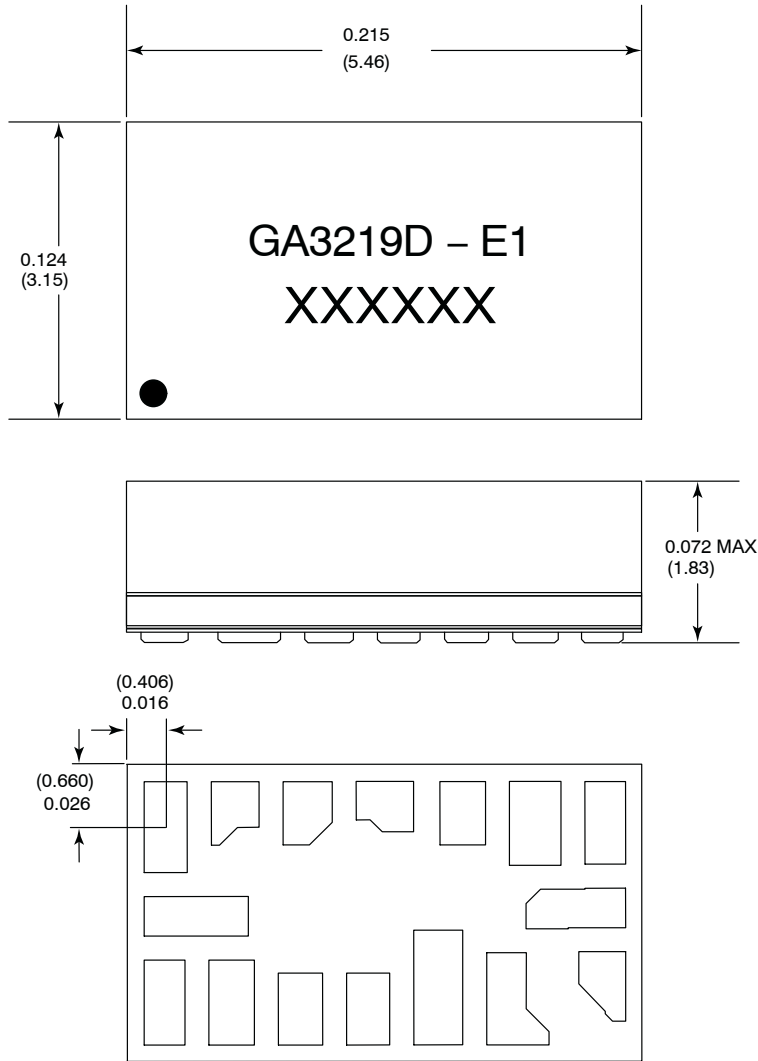

Dimension units are in inches.

Dimensions in parentheses are in millimeters, converted from inches and include minor rounding errors.

1.000 inches = 25.4 mm

Dimension tolerances: ± 0.005 (± 0.13) unless otherwise stated.

• = location of Pin 1

RoHS compliant hybrid, MSL#4, 240°C peak reflow, SAC305

This Hybrid is designed for either point-to-point manual soldering or for reflow according to ON Semiconductor's reflow process.

HRX is a trademark of Semiconductor Components Industries, LLC.

thinSTAX, FRONTWAVE and ARKonline are registered trademarks of Semiconductor Components Industries, LLC.

ON Semiconductor and the  are registered trademarks of Semiconductor Components Industries, LLC (SCILLC) or its subsidiaries in the United States and/or other countries. SCILLC owns the rights to a number of patents, trademarks, copyrights, trade secrets, and other intellectual property. A listing of SCILLC's product/patent coverage may be accessed at www.onsemi.com/site/pdf/Patent-Marking.pdf. SCILLC reserves the right to make changes without further notice to any products herein. SCILLC makes no warranty, representation or guarantee regarding the suitability of its products for any particular purpose, nor does SCILLC assume any liability arising out of the application or use of any product or circuit, and specifically disclaims any and all liability, including without limitation special, consequential or incidental damages. "Typical" parameters which may be provided in SCILLC data sheets and/or specifications can and do vary in different applications and actual performance may vary over time. All operating parameters, including "Typicals" must be validated for each customer application by customer's technical experts. SCILLC does not convey any license under its patent rights nor the rights of others. SCILLC products are not designed, intended, or authorized for use as components in systems intended for surgical implant into the body, or other applications intended to support or sustain life, or for any other application in which the failure of the SCILLC product could create a situation where personal injury or death may occur. Should Buyer purchase or use SCILLC products for any such unintended or unauthorized application, Buyer shall indemnify and hold SCILLC and its officers, employees, subsidiaries, affiliates, and distributors harmless against all claims, costs, damages, and expenses, and reasonable attorney fees arising out of, directly or indirectly, any claim of personal injury or death associated with such unintended or unauthorized use, even if such claim alleges that SCILLC was negligent regarding the design or manufacture of the part. SCILLC is an Equal Opportunity/Affirmative Action Employer. This literature is subject to all applicable copyright laws and is not for resale in any manner.

PUBLICATION ORDERING INFORMATION

LITERATURE FULFILLMENT:

Literature Distribution Center for ON Semiconductor
19521 E. 32nd Pkwy, Aurora, Colorado 80011 USA
Phone: 303-675-2175 or 800-344-3860 Toll Free USA/Canada
Fax: 303-675-2176 or 800-344-3867 Toll Free USA/Canada
Email: orderlit@onsemi.com

N. American Technical Support: 800-282-9855 Toll Free
USA/Canada
Europe, Middle East and Africa Technical Support:
Phone: 421 33 790 2910
Japan Customer Focus Center
Phone: 81-3-5817-1050

ON Semiconductor Website: www.onsemi.com
Order Literature: <http://www.onsemi.com/orderlit>

For additional information, please contact your local Sales Representative

GA3219/D