

NB6VQ572M

1.8V / 2.5V Differential 4:1 Mux w/Input Equalizer to 1:2 CML Clock/Data Fanout / Translator

Multi-Level Inputs w/ Internal Termination

Description

The NB6VQ572M is a high performance differential 4:1 Clock / Data input multiplexer and a 1:2 CML Clock / Data fanout buffer that operates up to 5 GHz / 6.5 Gbps respectively with a 1.8 V or 2.5 V power supply.

Each IN_x / \overline{IN}_x input pair incorporates a fixed Equalizer Receiver, which when placed in series with a Clock / Data path, will enhance the degraded signal transmitted across an FR4 backplane or cable interconnect. For applications that do not require Equalization, consider the NB7V572M, which is pin-compatible to the NB6VQ572M.

The differential Clock / Data inputs have internal 50 Ω termination resistors and will accept differential LVPECL, CML, or LVDS logic levels. The NB6VQ572M incorporates a pair of Select pins that will choose one of four differential inputs and will produce two identical CML output copies of Clock or Data.

As such, the NB6VQ572M is ideal for SONET, GigE, Fiber Channel, Backplane and other Clock/Data distribution applications. The two differential CML outputs will swing 400 mV when externally loaded and terminated with a 50 Ω resistor to V_{CC} and are optimized for low skew and minimal jitter.

The NB6VQ572M is offered in a low profile 5x5 mm 32-pin QFN Pb-Free package. Application notes, models, and support documentation are available at www.onsemi.com. The NB6VQ572M is a member of the ECLinPS MAX™ family of high performance clock products.

Features

- Input Data Rate > 6.5 Gb/s Typical
- Data Dependent Jitter < 10 ps
- Maximum Input Clock Frequency > 5 GHz Typical
- Random Clock Jitter < 0.8 ps RMS
- Low Skew 1:2 CML Outputs, < 15 ps max
- 4:1 Multi-Level Mux Inputs, accepts LVPECL, CML, LVDS
- 175 ps Typical Propagation Delay
- 45 ps Typical Rise and Fall Times
- Differential CML Outputs, 400 mV Peak-to-Peak, Typical
- Operating Range: $V_{CC} = 1.71 \text{ V to } 2.625 \text{ V}$ with GND = 0 V
- Internal 50 Ω Input Termination Resistors
- VREFAC Reference Output
- QFN-32 Package, 5mm x 5mm, Pb-Free
- -40°C to +85°C Ambient Operating Temperature
- These are Pb-Free Devices



ON Semiconductor®

<http://onsemi.com>

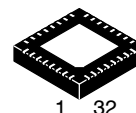

QFN32
MN SUFFIX
CASE 488AM

MARKING DIAGRAM

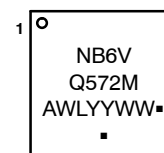

A = Assembly Location
WL = Wafer Lot
YY = Year
WW = Work Week
▪ = Pb-Free Package

(Note: Microdot may be in either location)

ORDERING INFORMATION

See detailed ordering and shipping information on page 10 of this data sheet.

NB6VQ572M

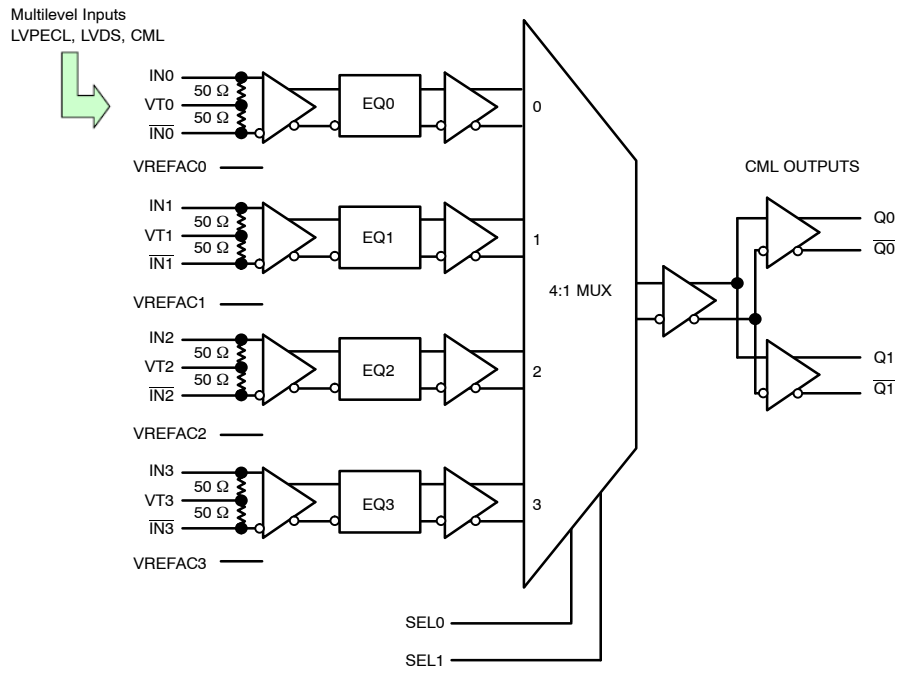

Figure 1. Simplified Block Diagram

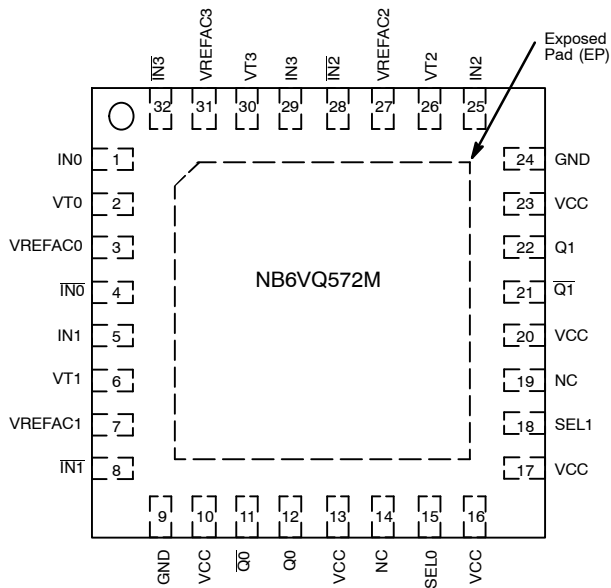

Figure 2. Pinout: QFN-32 (Top View)

Table 1. INPUT SELECT FUNCTION TABLE

SEL1*	SEL0*	Clock / Data Input Selected
0	0	IN0 Input Selected
0	1	IN1 Input Selected
1	0	IN2 Input Selected
1	1	IN3 Input Selected

*Defaults HIGH when left open.

NB6VQ572M

Table 2. PIN DESCRIPTION

Pin Number	Pin Name	I/O	Pin Description
1, 4 5, 8 25, 28 29, 32	IN0, $\overline{IN0}$ IN1, $\overline{IN1}$ IN2, $\overline{IN2}$ IN3, $\overline{IN3}$	LVPECL, CML, LVDS Input	Noninverted, Inverted, Differential Clock or Data Inputs
2, 6 26, 30	VT0, VT1 VT2, VT3		Internal 100 Ω Center-tapped Termination Pin for INx / \overline{INx}
15 18	SEL0 SEL1	LVTTTL/LVCMOS Input	Input Select pins, default HIGH when left open through a 94 k Ω pullup resistor. Input logic threshold is $V_{CC}/2$. See Select Function, Table 1.
14, 19	NC	–	No Connect
10, 13, 16 17, 20, 23	V _{CC}	–	Positive Supply Voltage.
11, 12 21, 22	$\overline{Q0}$, Q0 $\overline{Q1}$, Q1	CML Output	Inverted, Non-inverted Differential Outputs.
9, 24	GND		Negative Supply Voltage
3 7 27 31	VREFAC0 VREFAC1 VREFAC2 VREFAC3	–	Output Voltage Reference for Capacitor-Coupled Inputs
–	EP	–	The Exposed Pad (EP) on the QFN-32 package bottom is thermally connected to the die for improved heat transfer out of package. The exposed pad must be attached to a heat-sinking conduit. The pad is electrically connected to the die, and must be electrically connected to GND.

1. In the differential configuration when the input termination pins (VT0, VT1, VT2, VT3) are connected to a common termination voltage or left open, and if no signal is applied on INx/ \overline{INx} input, then the device will be susceptible to self-oscillation.
2. All V_{CC}, and GND pins must be externally connected to a power supply for proper operation.

NB6VQ572M

Table 3. ATTRIBUTES

Characteristics		Value
ESD Protection	Human Body Model Machine Model	> 2 kV > 200 V
R _{PU} – SELx Input Pullup Resistor		94kΩ
Moisture Sensitivity (Note 3)	QFN–32	Level 1
Flammability Rating	Oxygen Index: 28 to 34	UL 94 V–0 @ 0.125 in
Transistor Count		221
Meets or exceeds JEDEC Spec EIA/JESD78 IC Latchup Test		

3. For additional information, see Application Note AND8003/D.

Table 4. MAXIMUM RATINGS

Symbol	Parameter	Condition 1	Condition 2	Rating	Unit
V _{CC}	Positive Power Supply	GND = 0 V		3.0	V
V _{IN}	Positive Input Voltage	GND = 0 V		–0.5 to V _{CC} +0.5	V
V _{INPP}	Differential Input Voltage I _N – I _N			1.89	V
I _{out}	Output Current Through R _T (50 Ω Resistor)			± 40	mA
I _{IN}	Input current Through RT (50 Ω Resistor)			± 40	mA
I _{VREFAC}	V _{REFAC} Sink or Source Current			± 1.5	mA
T _A	Operating Temperature Range			–40 to +85	°C
T _{stg}	Storage Temperature Range			–65 to +150	°C
θ _{JA}	Thermal Resistance (Junction–to–Ambient) (Note 4)	0 lfpm 500 lfpm	QFN–32 QFN–32	31 27	°C/W °C/W
θ _{JC}	Thermal Resistance (Junction–to–Case) (Note 4)		QFN–32	12	°C/W
T _{sol}	Wave Solder	≤ 20 sec		265	°C

Stresses exceeding Maximum Ratings may damage the device. Maximum Ratings are stress ratings only. Functional operation above the Recommended Operating Conditions is not implied. Extended exposure to stresses above the Recommended Operating Conditions may affect device reliability.

4. JEDEC standard multilayer board – 2S2P (2 signal, 2 power) with 8 filled thermal vias under exposed pad.

NB6VQ572M

Table 5. DC CHARACTERISTICS CML OUTPUT $V_{CC} = 1.71\text{ V to }2.625\text{ V}$, $GND = 0\text{ V}$, $T_A = -40^\circ\text{C to }+85^\circ\text{C}$ (Note 5)

Symbol	Characteristic	Min	Typ	Max	Unit
--------	----------------	-----	-----	-----	------

POWER SUPPLY

V_{CC}	Power Supply Voltage	$V_{CC} = 2.5\text{ V}$ $V_{CC} = 1.8\text{ V}$	2.375 1.71	2.5 1.8	2.625 1.89	V
I_{CC}	Power Supply Current for V_{CC} (Inputs and Outputs Open)	$V_{CC} = 2.5\text{ V}$ $V_{CC} = 1.8\text{ V}$	70 60	105 85	140 120	mA

CML OUTPUTS (Note 6)

V_{OH}	Output HIGH Voltage	$V_{CC} = 2.5\text{ V}$ $V_{CC} = 1.8\text{ V}$	$V_{CC} - 30$ 2470 1770	$V_{CC} - 10$ 2490 1790	V_{CC} 2500 1800	mV
V_{OL}	Output LOW Voltage	$V_{CC} = 2.5\text{ V}$ $V_{CC} = 1.8\text{ V}$	$V_{CC} - 550$ 1950 1250	$V_{CC} - 450$ 2050 1350	$V_{CC} - 350$ 2150 1450	mV

DIFFERENTIAL CLOCK INPUTS DRIVEN SINGLE-ENDED (Figures 7 and 8) (Note 7)

V_{IH}	Single-ended Input HIGH Voltage		$V_{th} + 100$		V_{CC}	mV
V_{IL}	Single-ended Input LOW Voltage		GND		$V_{th} - 100$	mV
V_{th}	Input Threshold Reference Voltage Range (Note 8)		1100		$V_{CC} - 100$	mV
V_{ISE}	Single-ended Input Voltage ($V_{IH} - V_{IL}$)		200		1200	mV

VREFAC

V_{REFAC}	Output Reference Voltage (100 μA Load)		$V_{CC} - 700$	$V_{CC} - 550$	$V_{CC} - 450$	mV
-------------	---	--	----------------	----------------	----------------	----

DIFFERENTIAL INPUTS DRIVEN DIFFERENTIALLY (Figures 9 and 10) (Note 9)

V_{IHD}	Differential Input HIGH Voltage (I_N, \bar{I}_N)		1200		V_{CC}	mV
V_{ILD}	Differential Input LOW Voltage (I_N, \bar{I}_N)		0		$V_{IHD} - 100$	mV
V_{ID}	Differential Input Voltage (I_N, \bar{I}_N) ($V_{IHD} - V_{ILD}$)		100		1200	mV
V_{CMR}	Input Common Mode Range (Differential Configuration, Note 10) (Figure 11)		1150		$V_{CC} - 50$	mV
I_{IH}	Input HIGH Current I_N / \bar{I}_N (V_{TIN}/\bar{V}_{TIN} Open)		-150		150	μA
I_{IL}	Input LOW Current I_N / \bar{I}_N (V_{TIN}/\bar{V}_{TIN} Open)		-150		150	μA

CONTROL INPUT (SELx Pin)

V_{IH}	Input HIGH Voltage for Control Pin		$V_{CC} \times 0.65$		V_{CC}	V
V_{IL}	Input LOW Voltage for Control Pin		GND		$V_{CC} \times 0.35$	V
I_{IH}	Input HIGH Current		-150		150	μA
I_{IL}	Input LOW Current		-150		150	μA

TERMINATION RESISTORS

R_{TIN}	Internal Input Termination Resistor (Measured from I_N to V_{TX})		45	50	55	Ω
R_{TOUT}	Internal Output Termination Resistor		45	50	55	Ω

NOTE: Device will meet the specifications after thermal equilibrium has been established when mounted in a test socket or printed circuit board with maintained transverse airflow greater than 500 lfm. Electrical parameters are guaranteed only over the declared operating temperature range. Functional operation of the device exceeding these conditions is not implied. Device specification limit values are applied individually under normal operating conditions and not valid simultaneously.

- Input and Output parameters vary 1:1 with V_{CC} .
- CML outputs loaded with 50 Ω to V_{CC} for proper operation.
- V_{th} , V_{IH} , V_{IL} , and V_{ISE} parameters must be complied with simultaneously.
- V_{th} is applied to the complementary input when operating in single-ended mode.
- V_{IHD} , V_{ILD} , V_{ID} and V_{CMR} parameters must be complied with simultaneously.
- V_{CMR} min varies 1:1 with GND, V_{CMR} max varies 1:1 with V_{CC} . The V_{CMR} range is referenced to the most positive side of the differential input signal.

NB6VQ572M

Table 6. AC CHARACTERISTICS $V_{CC} = 1.71\text{ V to }2.625\text{ V}$, $GND = 0\text{ V}$, $T_A = -40^\circ\text{C to }+85^\circ\text{C}$ (Note 11)

Symbol	Characteristic	Min	Typ	Max	Unit
f_{MAX}	Maximum Input Clock Frequency $V_{OUT} \geq 250\text{ mV}$	5	6		GHz
$f_{DATAMAX}$	Maximum Operating Data Rate NRZ, (PRBS23)	6.5	8		Gbps
f_{SEL}	Maximum Toggle Frequency, SELx	4	10		MHz
V_{OUTPP}	Output Voltage Amplitude (@ $V_{INPPmin}$) (Note 12) (Figure 12) $f_{in} \leq 5\text{ GHz}$	250	400		mV
t_{PLH} , t_{PHL}	Propagation Delay to Differential Outputs Measured at Differential Crosspoint @ 1 GHz INx/INx to Qx/Qx @ 50 MHz SELx to Qx	100	175 7	250 20	ps ns
$t_{PD\ Tempco}$	Differential Propagation Delay Temperature Coefficient		50		$\Delta fs/^\circ C$
t_{skew}	Output – Output skew (within device) (Note 13) Device – Device skew ($t_{pdmax} - t_{pdmin}$)		0 30	15 100	ps
t_{DC}	Output Clock Duty Cycle (Reference Duty Cycle = 50%) $f_{in} \leq 5\text{ GHz}$	45	50	55	%
Φ_N	Phase Noise, $f_{in} = 1\text{ GHz}$ 10 kHz 100 kHz 1 MHz 10 MHz 20 MHz 40 MHz		-135 -136 -149 -150 -150 -151		dBc
$t_{J\Phi N}$	Integrated Phase Jitter (Figure TBD) $f_{in} = 1\text{ GHz}$, 12 kHz – 20 MHz Offset (RMS)		35		fs
t_{JITTER}	Random Clock Jitter, RJ (Note 14) Deterministic Jitter, DJ (Note 15) $f_{in} \leq 5\text{ GHz}$		0.2	0.8	ps RMS
	Crosstalk Induced Jitter (Adjacent Channel) (Note 17) $f_{in} \leq 6.5\text{ Gbps}$ (12" FR4)			10	ps pk-pk
V_{INPP}	Input Voltage Swing (Differential Configuration) (Note 16)	100		1200	mV
t_r , t_f	Output Rise/Falltimes @ 1 GHz; (20% – 80%), $V_{IN} = 400\text{ mV}$ Qx, Qx	25	45	65	ps

NOTE: Device will meet the specifications after thermal equilibrium has been established when mounted in a test socket or printed circuit board with maintained transverse airflow greater than 500 lfm. Electrical parameters are guaranteed only over the declared operating temperature range. Functional operation of the device exceeding these conditions is not implied. Device specification limit values are applied individually under normal operating conditions and not valid simultaneously.

11. Measured using a 100 mVpk-pk source, 50% duty cycle clock source. All output loading with external 50 Ω to V_{CC} . Input edge rates 40 ps (20% – 80%).
12. Output voltage swing is a single-ended measurement operating in differential mode.
13. Skew is measured between outputs under identical transitions and conditions. Duty cycle skew is defined only for differential operation when the delays are measured from crosspoint of the inputs to the crosspoint of the outputs.
14. Additive RMS jitter with 50% duty cycle clock signal.
15. Additive Peak-to-Peak data dependent jitter with input NRZ data at PRBS23.
16. Input voltage swing is a single-ended measurement operating in differential mode.
17. Crosstalk is measured at the output while applying two similar clock frequencies that are asynchronous with respect to each other at the inputs.

NB6VQ572M

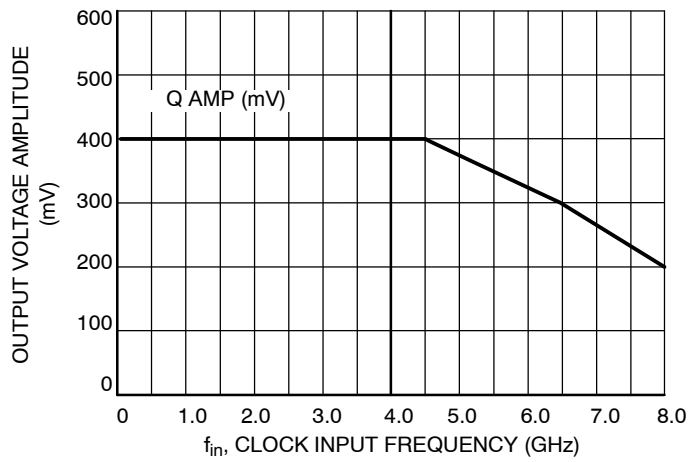

Figure 3. Clock Output Voltage Amplitude (V_{OUTPP}) vs. Input Frequency (f_{in}) at Ambient Temperature (Typical)

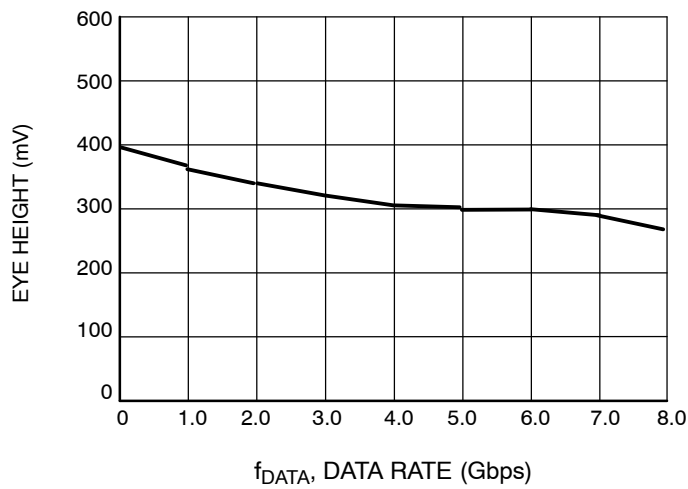

Figure 4. Inside Eye Height vs. Input Data Rate (Gbps) at Ambient Temperature (typical), FR4 = 12"

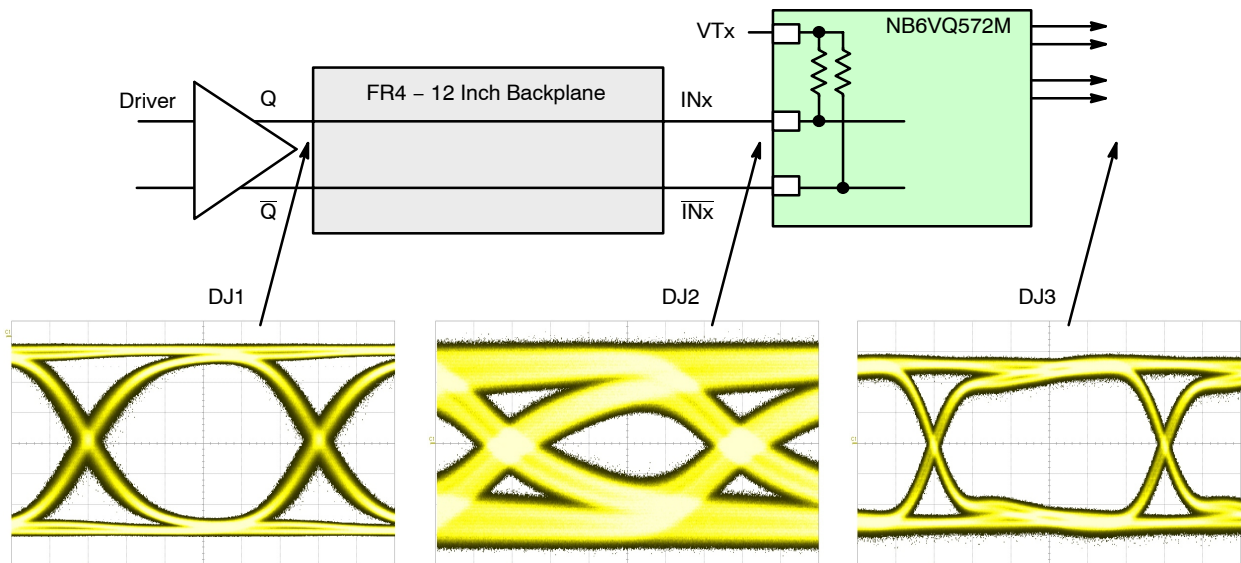

Figure 5. Typical NB6VQ572M Equalizer Application and Interconnect with PRBS23 Pattern at 6.5 Gbps

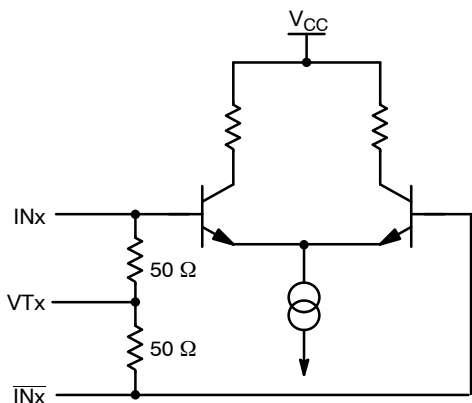

Figure 6. Input Structure

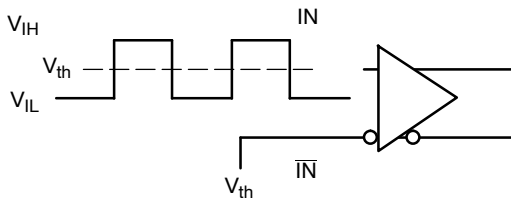

Figure 7. Differential Input Driven Single-Ended

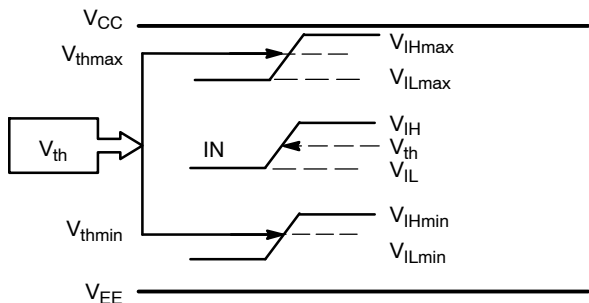

Figure 8. V_{th} Diagram

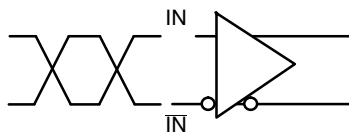

Figure 9. Differential Inputs Driven Differentially

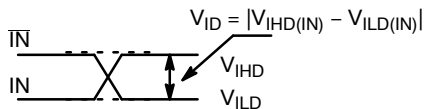

Figure 10. Differential Inputs Driven Differentially

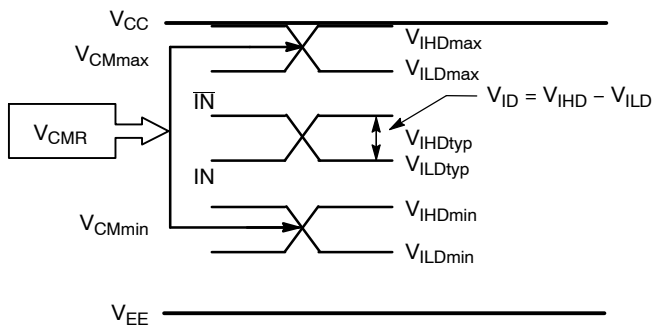

Figure 11. V_{CMR} Diagram

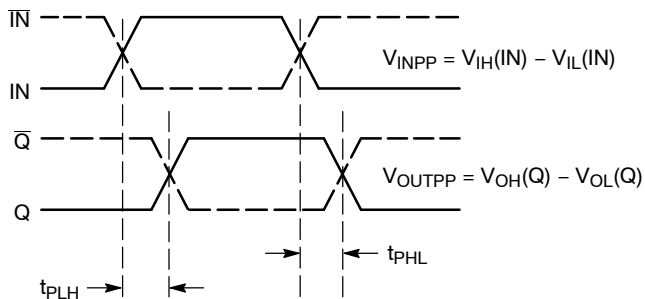

Figure 12. AC Reference Measurement

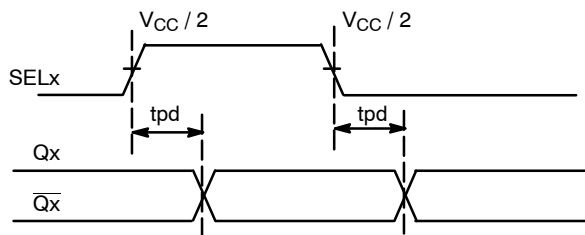

Figure 13. SEL_x to Q_x Timing Diagram

NB6VQ572M

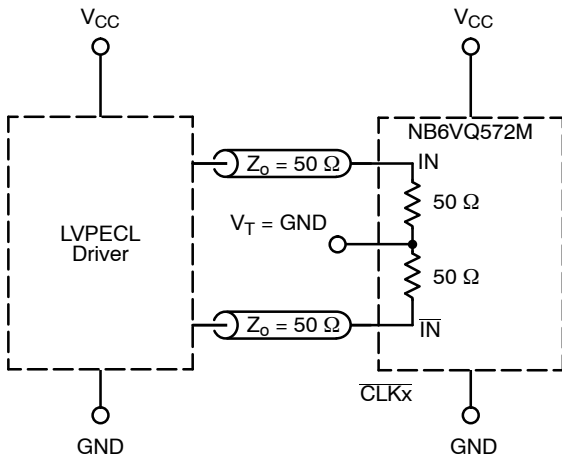

Figure 14. LVPECL Interface

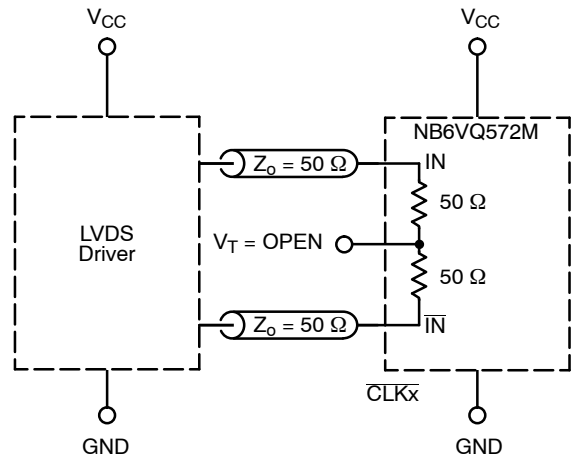

Figure 15. LVDS Interface

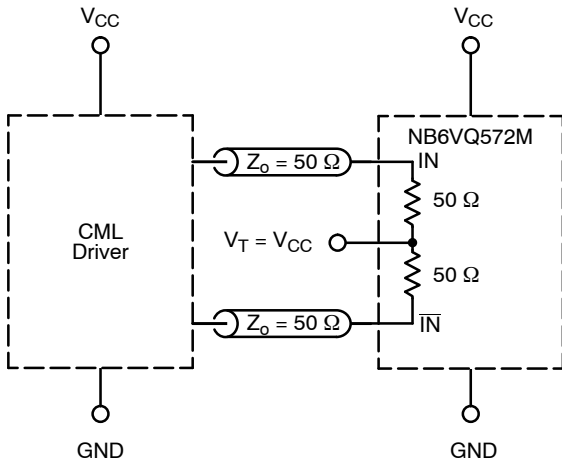

Figure 16. Standard 50 Ω Load CML Interface

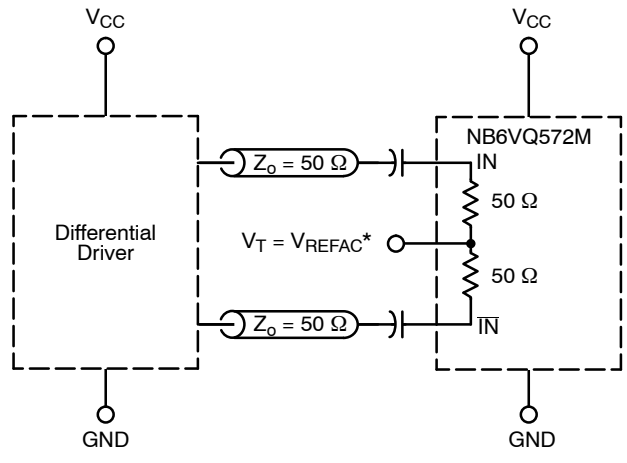

Figure 17. Capacitor-Coupled Differential Interface (V_T Connected to V_{REFAC})

* V_{REFAC} bypassed to ground with a 0.01 μ F capacitor.

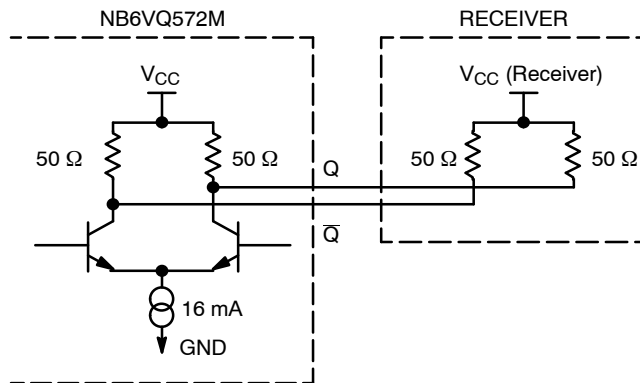

Figure 18. Typical CML Output Structure and Termination

NB6VQ572M

DEVICE ORDERING INFORMATION

Device	Package	Shipping†
NB6VQ572MMNG	QFN-32 (Pb-free)	74 Units / Rail
NB6VQ572MMNR4G	QFN-32 (Pb-free)	1000 / Tape & Reel

†For information on tape and reel specifications, including part orientation and tape sizes, please refer to our Tape and Reel Packaging Specifications Brochure, BRD8011/D.

NB6VQ572M

PACKAGE DIMENSIONS

QFN32 5*5*1 0.5 P
CASE 488AM-01
ISSUE O

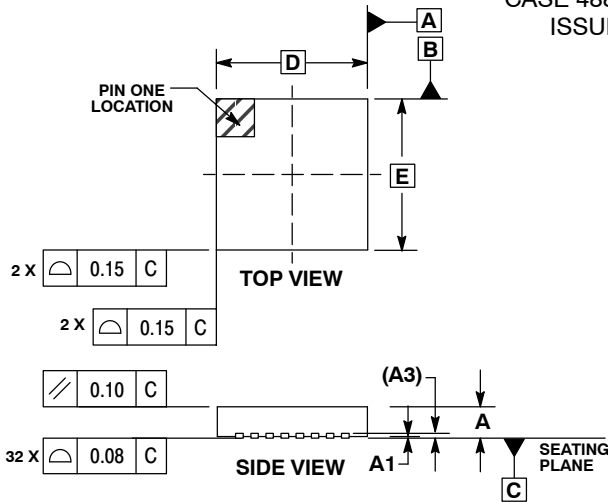

NOTES:

1. DIMENSIONS AND TOLERANCING PER ASME Y14.5M, 1994.
2. CONTROLLING DIMENSION: MILLIMETERS.
3. DIMENSION b APPLIES TO PLATED TERMINAL AND IS MEASURED BETWEEN 0.25 AND 0.30 MM TERMINAL.
4. COPLANARITY APPLIES TO THE EXPOSED PAD AS WELL AS THE TERMINALS.

DIM	MILLIMETERS		
	MIN	NOM	MAX
A	0.800	0.900	1.000
A1	0.000	0.025	0.050
A3	0.200 REF		
b	0.180	0.250	0.300
D	5.00 BSC		
D2	2.950	3.100	3.250
E	5.00 BSC		
E2	2.950	3.100	3.250
e	0.500 BSC		
K	0.200	---	---
L	0.300	0.400	0.500

SOLDERING FOOTPRINT*

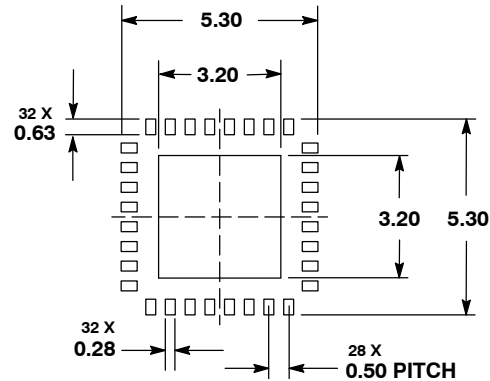

*For additional information on our Pb-Free strategy and soldering details, please download the ON Semiconductor Soldering and Mounting Techniques Reference Manual, SOLDERRM/D.

ECLinPS MAX is a trademark of Semiconductor Components Industries, LLC (SCILLC).

ON Semiconductor and are registered trademarks of Semiconductor Components Industries, LLC (SCILLC). SCILLC reserves the right to make changes without further notice to any products herein. SCILLC makes no warranty, representation or guarantee regarding the suitability of its products for any particular purpose, nor does SCILLC assume any liability arising out of the application or use of any product or circuit, and specifically disclaims any and all liability, including without limitation special, consequential or incidental damages. "Typical" parameters which may be provided in SCILLC data sheets and/or specifications can and do vary in different applications and actual performance may vary over time. All operating parameters, including "Typicals" must be validated for each customer application by customer's technical experts. SCILLC does not convey any license under its patent rights nor the rights of others. SCILLC products are not designed, intended, or authorized for use as components in systems intended for surgical implant into the body, or other applications intended to support or sustain life, or for any other application in which the failure of the SCILLC product could create a situation where personal injury or death may occur. Should Buyer purchase or use SCILLC products for any such unintended or unauthorized application, Buyer shall indemnify and hold SCILLC and its officers, employees, subsidiaries, affiliates, and distributors harmless against all claims, costs, damages, and expenses, and reasonable attorney fees arising out of, directly or indirectly, any claim of personal injury or death associated with such unintended or unauthorized use, even if such claim alleges that SCILLC was negligent regarding the design or manufacture of the part. SCILLC is an Equal Opportunity/Affirmative Action Employer. This literature is subject to all applicable copyright laws and is not for resale in any manner.

PUBLICATION ORDERING INFORMATION

LITERATURE FULFILLMENT:
Literature Distribution Center for ON Semiconductor
P.O. Box 5163, Denver, Colorado 80217 USA
Phone: 303-675-2175 or 800-344-3860 Toll Free USA/Canada
Fax: 303-675-2176 or 800-344-3867 Toll Free USA/Canada
Email: orderlit@onsemi.com

N. American Technical Support: 800-282-9855 Toll Free
USA/Canada
Europe, Middle East and Africa Technical Support:
Phone: 421 33 790 2910
Japan Customer Focus Center
Phone: 81-3-5773-3850

ON Semiconductor Website: www.onsemi.com
Order Literature: <http://www.onsemi.com/orderlit>

For additional information, please contact your local Sales Representative

NB6VQ572M/D