

NB3N1200K, NB3W1200L

3.3 V 100/133 MHz Differential 1:12 HCSL or Push-Pull Clock ZDB/Fanout Buffer for PCIe

Description

The NB3N1200K and NB3W1200L differential clock buffers are DB1200Z and DB1200ZL compliant and are designed to work in conjunction with a PCIe compliant source clock synthesizer to provide point-to-point clocks to multiple agents. The device is capable of distributing the reference clocks for Intel® QuickPath Interconnect (Intel QPI & UPI), PCIe Gen1/Gen2/Gen3/Gen4, SAS, SATA, and Intel Scalable Memory Interconnect (Intel SMI) applications. The VCO of the device is optimized to support 100 MHz and 133 MHz frequency operation. The NB3N1200K and NB3W1200L utilize pseudo-external feedback topology to achieve low input-to output delay variation. The NB3N1200K is configured with the HCSL buffer type, while the NB3W1200L is configured with the low-power NMOS Push-Pull buffer type.

Features

- 12 Differential Clock Output Pairs @ 0.7 V
- HCSL Compatible Outputs for NB3N1200K
- Low-Power NMOS Push-Pull Compatible Outputs for NB3W1200L
- Optimized 100 MHz and 133 MHz Operating Frequencies to Meet The Next Generation PCIe Gen2/Gen3/Gen4 and Intel QPI & UPI Phase Jitter
- DB1200Z and DB1200ZL Compliant
- 3.3 V $\pm 5\%$ Supply Voltage Operation
- Fixed-Feedback for Lowest Input-To-Output Delay Variation
- SMBus Programmable Configurations to Allow Multiple Buffers in a Single Control Network
- PLL Bypass Configurable for PLL or Fanout Operation
- Programmable PLL Bandwidth
- 2 Tri-level Addresses Selection (9 SMBUS Addresses)
- Individual OE Control Pin for Each of 12 Outputs
- 50 ps Max Output-to-Output Skew Performance
- 50 ps Max Cycle-to-Cycle Jitter (PLL mode)
- 100 ps Input to Output Delay Variation Performance
- QFN 64-pin Package, 9 mm x 9 mm
- Spread Spectrum Compatible: Tracks Input Clock Spreading for Low EMI
- 0°C to +70°C Ambient Operating Temperature
- These Devices are Pb-Free and are RoHS Compliant



ON Semiconductor®

www.onsemi.com

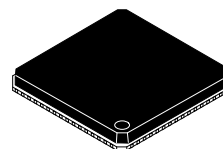

64 1

QFN64
MN SUFFIX
CASE 485DH

MARKING DIAGRAMS

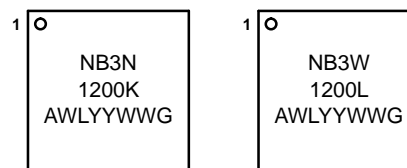

NB3x1200x= Specific Device Code
A = Assembly Location
WL = Wafer Lot
YY = Year
WW = Work Week
G = Pb-Free Package

ORDERING INFORMATION

Device	Package	Shipping†
NB3N1200KMNG	QFN-64 (Pb-Free)	260 Units / Tray
NB3N1200KMNTXG	QFN-64 (Pb-Free)	1000 / Tape & Reel
NB3W1200LMNG	QFN-64 (Pb-Free)	260 Units / Tray
NB3W1200LMNTXG	QFN-64 (Pb-Free)	1000 / Tape & Reel

†For information on tape and reel specifications, including part orientation and tape sizes, please refer to our Tape and Reel Packaging Specification Brochure, BRD8011/D.

NB3N1200K, NB3W1200L

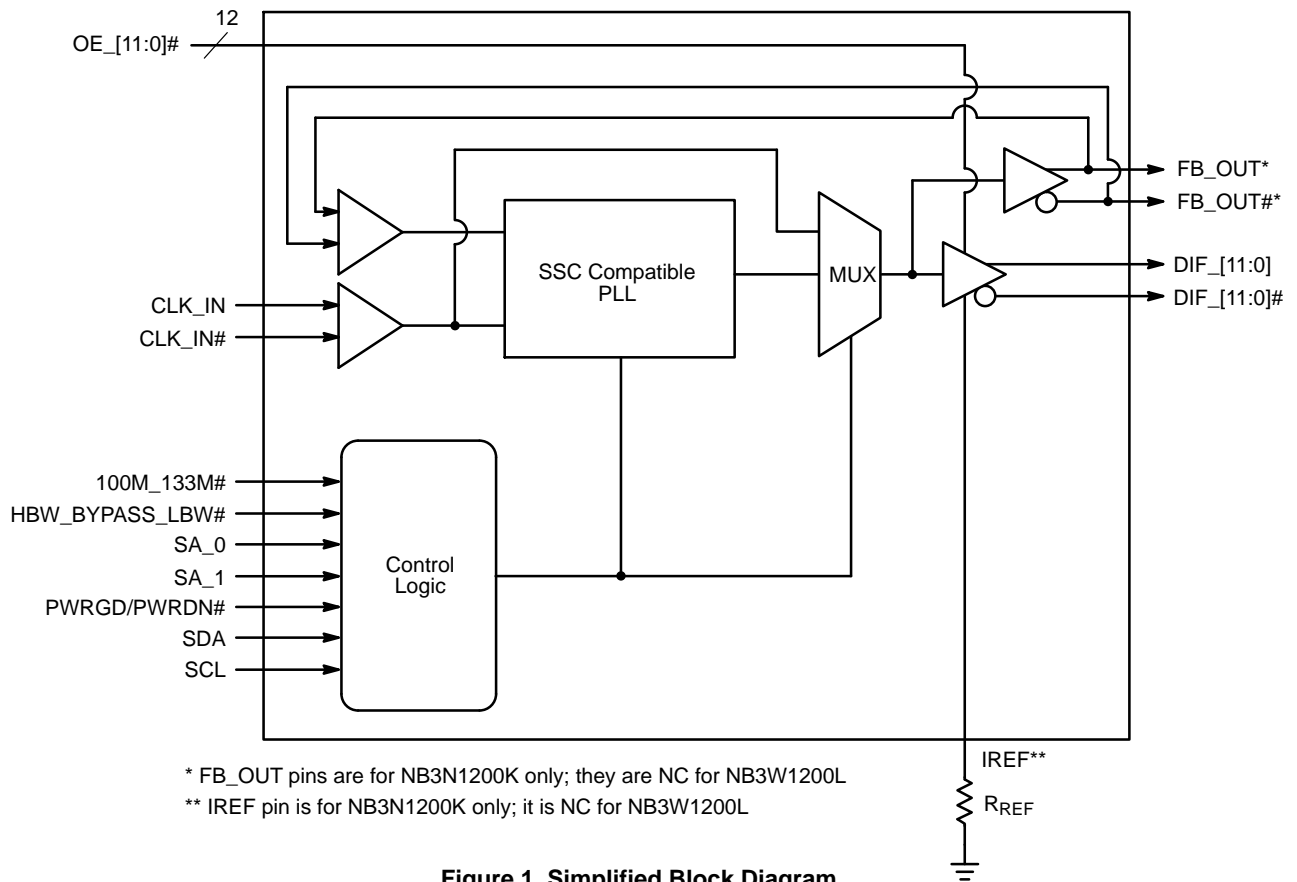

Figure 1. Simplified Block Diagram

NB3N1200K, NB3W1200L

PIN CONNECTIONS

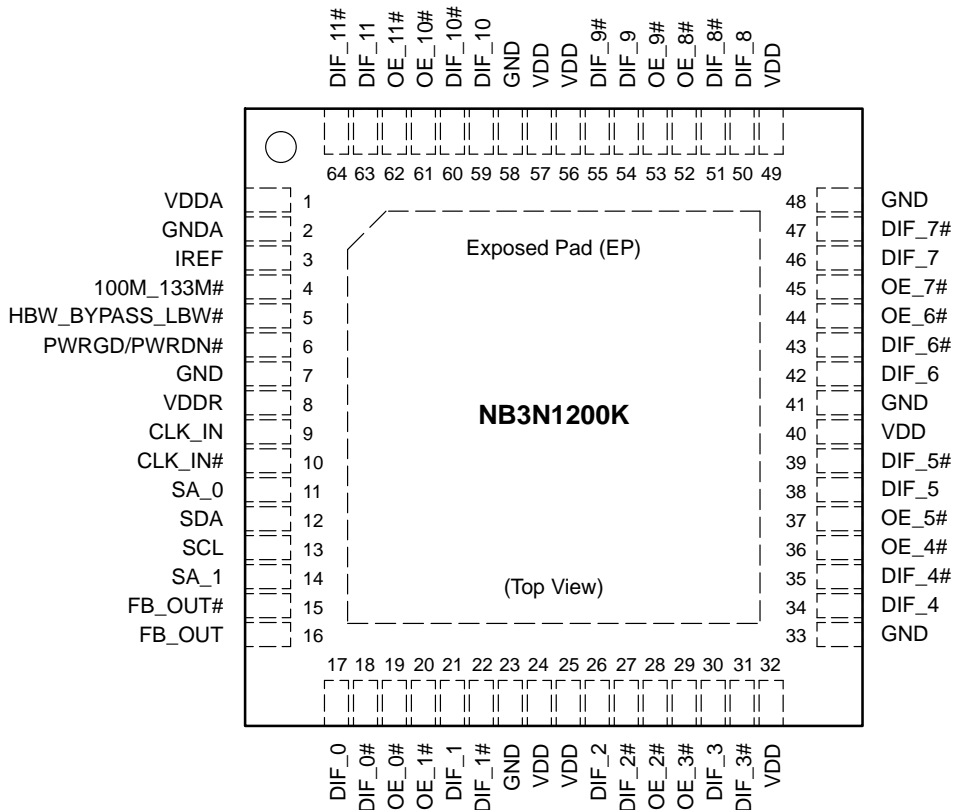

Figure 2. NB3N1200K Pinout: QFN-64 (Top View)

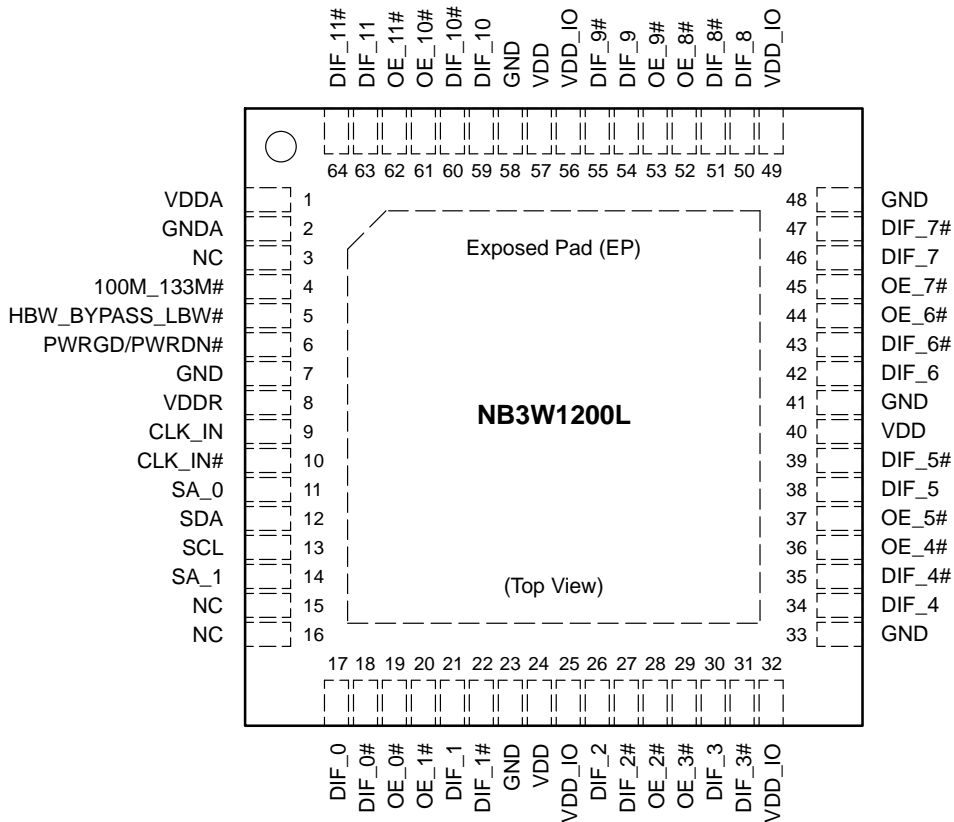

Figure 3. NB3W1200L Pinout: QFN-64 (Top View)

NB3N1200K, NB3W1200L

Table 1. NB3N1200K PIN DESCRIPTIONS

Pin Number	Pin Name	Type	Description
1	VDDA	3.3 V	3.3 V Power Supply for PLL.
2	GND A	GND	Ground for PLL.
3	IREF	I	A precision resistor is attached to this pin to set the differential output current. Use $R_{REF} = 475 \Omega$, 1% for 100 Ohms trace. Use $R_{REF} = 412 \Omega$, 1% for 85 Ohms trace.
4	100M_133M#	I, SE	Input/output Frequency Selection (FS). An external pull-up or pull-down resistor is attached to this pin to select the input/output frequency. High = 100 MHz Output Low = 133 MHz Output
5	HBW_BYPASS_LBW#	I, SE	Tri-Level input for selecting the PLL bandwidth or bypass mode (refer to tri-level threshold in Table 4). High = High BW mode Med = Bypass mode Low = Low BW mode
6	PWRGD / PWRDN#	I, SE	3.3 V LVTTTL input to power up or power down the device.
7	GND	GND	Ground for outputs.
8	VDDR	VDD	3.3 V power supply for receiver.
9	CLK_IN	I, DIF	0.7 V Differential True input
10	CLK_IN#	I, DIF	0.7 V Differential Complementary input
11	SA_0	I, SE	3.3 V LVTTTL input selecting the address. Tri-level input (refer to tri-level threshold in Table 4.)
12	SDA	I/O	Open collector SMBus data.
13	SCL	I/O	SMBus slave clock input.
14	SA_1	I, SE	3.3 V LVTTTL input selecting the address. Tri-level input (refer to tri-level threshold in Table 4.)
15	FB_OUT#	O, DIF	Complementary Feedback out pin, termination required. See External Feedback Termination section.
16	FB_OUT	O, DIF	True Feedback out pin, termination required. See External Feedback Termination section.
17	DIF_0	O, DIF	0.7 V Differential True clock output
18	DIF_0#	O, DIF	0.7 V Differential Complementary clock output
19	OE_0#	I, SE	3.3 V LVTTTL active low input for enabling DIF output pair 0. 0 enables outputs, 1 disables outputs. Internal pull down.
20	OE_1#	I, SE	3.3 V LVTTTL active low input for enabling DIF output pair 1. 0 enables outputs, 1 disables outputs. Internal pull down.
21	DIF_1	O, DIF	0.7 V Differential True clock output
22	DIF_1#	O, DIF	0.7 V Differential Complementary clock output
23	GND	GND	Ground for outputs.
24	VDD	3.3 V	3.3 V power supply for outputs.
25	VDD	3.3 V	3.3 V power supply for outputs.
26	DIF_2	O, DIF	0.7 V Differential True clock output
27	DIF_2#	O, DIF	0.7 V Differential Complementary clock output
28	OE_2#	I, SE	3.3 V LVTTTL active low input for enabling DIF output pair 2. 0 enables outputs, 1 disables outputs. Internal pull down.
29	OE_3#	I, SE	3.3 V LVTTTL active low input for enabling DIF output pair 3. 0 enables outputs, 1 disables outputs. Internal pull down.
30	DIF_3	O, DIF	0.7 V Differential True clock output
31	DIF_3#	O, DIF	0.7 V Differential Complementary clock output
32	VDD	3.3 V	3.3 V power supply for outputs.
33	GND	GND	Ground for outputs.

NB3N1200K, NB3W1200L

Table 1. NB3N1200K PIN DESCRIPTIONS

Pin Number	Pin Name	Type	Description
34	DIF_4	O, DIF	0.7 V Differential True clock output
35	DIF_4#	O, DIF	0.7 V Differential Complementary clock output
36	OE_4#	I, SE	3.3 V LVTTTL active low input for enabling DIF output pair 4. 0 enables outputs, 1 disables outputs. Internal pull down.
37	OE_5#	I, SE	3.3 V LVTTTL active low input for enabling DIF output pair 5. 0 enables outputs, 1 disables outputs. Internal pull down.
38	DIF_5	O, DIF	0.7 V Differential True clock output
39	DIF_5#	O, DIF	0.7 V Differential Complementary clock output
40	VDD	3.3 V	3.3 V power supply for outputs.
41	GND	GND	Ground for outputs.
42	DIF_6	O, DIF	0.7 V Differential True clock output
43	DIF_6#	O, DIF	0.7 V Differential Complementary clock output
44	OE_6#	I, SE	3.3 V LVTTTL active low input for enabling DIF output pair 6. 0 enables outputs, 1 disables outputs. Internal pull down.
45	OE_7#	I, SE	3.3 V LVTTTL active low input for enabling DIF output pair 7. 0 enables outputs, 1 disables outputs. Internal pull down.
46	DIF_7	O, DIF	0.7 V Differential True clock output
47	DIF_7#	O, DIF	0.7 V Differential Complementary clock output
48	GND	GND	Ground for outputs.
49	VDD	3.3 V	3.3 V power supply for outputs.
50	DIF_8	O, DIF	0.7 V Differential True clock output
51	DIF_8#	O, DIF	0.7 V Differential Complementary clock output
52	OE_8#	I, SE	3.3 V LVTTTL active low input for enabling DIF output pair 8. 0 enables outputs, 1 disables outputs. Internal pull down.
53	OE_9#	I, SE	3.3 V LVTTTL active low input for enabling DIF output pair 9. 0 enables outputs, 1 disables outputs. Internal pull down.
54	DIF_9	O, DIF	0.7 V Differential True clock output
55	DIF_9#	O, DIF	0.7 V Differential Complementary clock output
56	VDD	3.3 V	3.3 V power supply for outputs.
57	VDD	3.3 V	3.3 V power supply for outputs.
58	GND	GND	Ground for outputs.
59	DIF_10	O, DIF	0.7 V Differential True clock output
60	DIF_10#	O, DIF	0.7 V Differential Complementary clock output
61	OE_10#	I, SE	3.3 V LVTTTL active low input for enabling DIF output pair 10. 0 enables outputs, 1 disables outputs. Internal pull down.
62	OE_11#	I, SE	3.3 V LVTTTL active low input for enabling DIF output pair 11. 0 enables outputs, 1 disables outputs. Internal pull down.
63	DIF_11	O, DIF	0.7 V Differential True clock output
64	DIF_11#	O, DIF	0.7 V Differential Complementary clock output
EP	Exposed Pad	Thermal	The Exposed Pad (EP) on the QFN–64 package bottom is thermally connected to the die for improved heat transfer out of package. The exposed pad must be attached to a heat–sinking conduit. The pad is electrically connected to the die, and must be electrically and thermally connected to GND on the PC board.

NB3N1200K, NB3W1200L

Table 2. NB3W1200L PIN DESCRIPTIONS

Pin Number	Pin Name	Type	Description
1	VDDA	3.3 V	3.3 V Power Supply for PLL.
2	GNDA	GND	Ground for PLL.
3	NC	I/O	No Connect
4	100M_133M#	I, SE	3.3 V tolerant inputs for input/output Frequency Selection (FS). An external pull-up or pull-down resistor is attached to this pin to select the input/output frequency. High = 100 MHz Output Low = 133 MHz Output
5	HBW_BYPASS_LBW#	I, SE	Tri-Level input for selecting the PLL bandwidth or bypass mode (refer to tri-level threshold in Table 4). High = High BW mode, Med = Bypass mode, Low = Low BW mode
6	PWRGD / PWRDN#	I	3.3 V LVTTTL input to power up or power down the device.
7	GND	GND	Ground for outputs.
8	VDDR	VDD	3.3 V power supply for receiver.
9	CLK_IN	I, DIF	0.7 V Differential True input
10	CLK_IN#	I, DIF	0.7 V Differential Complementary input
11	SA_0	I	3.3 V LVTTTL input selecting the address. Tri-level input (refer to tri-level threshold in Table 4.)
12	SDA	I/O	Open collector SMBus data.
13	SCL	I/O	SMBus slave clock input.
14	SA_1	I	3.3 V LVTTTL input selecting the address. Tri-level input (refer to tri-level threshold in Table 4.)
15	NC	I/O	No Connect. There are active signals on pin 15; do not connect anything to this pin.
16	NC	I/O	No Connect. There are active signals on pin 16; do not connect anything to this pin.
17	DIF_0	O, DIF	0.7 V Differential True clock output
18	DIF_0#	O, DIF	0.7 V Differential Complementary clock output
19	OE_0#	I, SE	3.3 V LVTTTL active low input for enabling DIF output pair 0. 0 enables outputs, 1 disables outputs. Internal pull down.
20	OE_1#	I, SE	3.3 V LVTTTL active low input for enabling DIF output pair 1. 0 enables outputs, 1 disables outputs. Internal pull down.
21	DIF_1	O, DIF	0.7 V Differential True clock output
22	DIF_1#	O, DIF	0.7 V Differential Complementary clock output
23	GND	GND	Ground for outputs.
24	VDD	3.3 V	3.3 V power supply for core.
25	VDD_IO	VDD	Power supply for differential outputs.
26	DIF_2	O, DIF	0.7 V Differential True clock output
27	DIF_2#	O, DIF	0.7 V Differential Complementary clock output
28	OE_2#	I, SE	3.3 V LVTTTL active low input for enabling DIF output pair 2. 0 enables outputs, 1 disables outputs. Internal pull down.
29	OE_3#	I, SE	3.3 V LVTTTL active low input for enabling DIF output pair 3. 0 enables outputs, 1 disables outputs. Internal pull down.
30	DIF_3	O, DIF	0.7 V Differential True clock output
31	DIF_3#	O, DIF	0.7 V Differential Complementary clock output
32	VDD_IO	VDD	Power supply for differential outputs.
33	GND	GND	Ground for outputs.

NB3N1200K, NB3W1200L

Table 2. NB3W1200L PIN DESCRIPTIONS

Pin Number	Pin Name	Type	Description
34	DIF_4	O, DIF	0.7 V Differential True clock output
35	DIF_4#	O, DIF	0.7 V Differential Complementary clock output
36	OE_4#	I, SE	3.3 V LVTTTL active low input for enabling DIF output pair 4. 0 enables outputs, 1 disables outputs. Internal pull down.
37	OE_5#	I, SE	3.3 V LVTTTL active low input for enabling DIF output pair 5. 0 enables outputs, 1 disables outputs. Internal pull down.
38	DIF_5	O, DIF	0.7 V Differential True clock output
39	DIF_5#	O, DIF	0.7 V Differential Complementary clock output
40	VDD	3.3 V	3.3 V power supply for core.
41	GND	GND	Ground for outputs.
42	DIF_6	O, DIF	0.7 V Differential True clock output
43	DIF_6#	O, DIF	0.7 V Differential Complementary clock output
44	OE_6#	I, SE	3.3 V LVTTTL active low input for enabling DIF output pair 6. 0 enables outputs, 1 disables outputs. Internal pull down.
45	OE_7#	I, SE	3.3 V LVTTTL active low input for enabling DIF output pair 7. 0 enables outputs, 1 disables outputs. Internal pull down.
46	DIF_7	O, DIF	0.7 V Differential True clock output
47	DIF_7#	O, DIF	0.7 V Differential Complementary clock output
48	GND	GND	Ground for outputs.
49	VDD_IO	VDD	Power supply for differential outputs.
50	DIF_8	O, DIF	0.7 V Differential True clock output
51	DIF_8#	O, DIF	0.7 V Differential Complementary clock output
52	OE_8#	I, SE	3.3 V LVTTTL active low input for enabling DIF output pair 8. 0 enables outputs, 1 disables outputs. Internal pull down.
53	OE_9#	I, SE	3.3 V LVTTTL active low input for enabling DIF output pair 9. 0 enables outputs, 1 disables outputs. Internal pull down.
54	DIF_9	O, DIF	0.7 V Differential True clock output
55	DIF_9#	O, DIF	0.7 V Differential Complementary clock output
56	VDD_IO	VDD	Power supply for differential outputs.
57	VDD	3.3 V	3.3 V power supply for core.
58	GND	GND	Ground for outputs.
59	DIF_10	O, DIF	0.7 V Differential True clock output
60	DIF_10#	O, DIF	0.7 V Differential Complementary clock output
61	OE_10#	I, SE	3.3 V LVTTTL active low input for enabling DIF output pair 10. 0 enables outputs, 1 disables outputs. Internal pull down.
62	OE_11#	I, SE	3.3 V LVTTTL active low input for enabling DIF output pair 11. 0 enables outputs, 1 disables outputs. Internal pull down.
63	DIF_11	O, DIF	0.7 V Differential True clock output
64	DIF_11#	O, DIF	0.7 V Differential Complementary clock output
EP	Exposed Pad	Thermal	The Exposed Pad (EP) on the QFN–64 package bottom is thermally connected to the die for improved heat transfer out of package. The exposed pad must be attached to a heat–sinking conduit. The pad is electrically connected to the die, and must be electrically and thermally connected to GND on the PC board.

NB3N1200K, NB3W1200L

Table 3. MAXIMUM RATINGS

Symbol	Parameter	Condition	Min	Max	Units
$V_{DD}/V_{DDA}/V_{DDR}$	Core Supply Voltage			4.6	V
V_{DD_IO}	I/O Supply Voltage			4.6	V
V_{IH} (Note 1)	Input High Voltage			4.6	V
V_{IHSMB}	SMB Input High Voltage	SDA, SCL Pins		5.5	V
V_{IL}	3.3 V Input Low Voltage		-0.5		V
t_s	Storage Temperature		-65	150	°C
ESD prot.	Input ESD protection	Human Body Model	2000		V
θ_{JA}	Thermal Resistance (Junction-to-Ambient)	0 lfpm 500 lfpm		22 15	°C/W
I_{OUTmax}	Maximum Output Current	Powerdown Mode (PWRGD/PWRDN# = 0) NB3N1200K All Pairs Tri-stated NB3W1200L All Pairs Tri-state Low/Low		24 12	mA

Stresses exceeding those listed in the Maximum Ratings table may damage the device. If any of these limits are exceeded, device functionality should not be assumed, damage may occur and reliability may be affected.

1. Maximum V_{IH} is not to exceed maximum V_{DD} .

Table 4. DC OPERATING CHARACTERISTICS ($V_{DD} = V_{DDA} = V_{DDR} = 3.3\text{ V} \pm 5\%$, $T_A = 0^\circ\text{C} - 70^\circ\text{C}$)

Symbol	Parameter	Condition	Min	Max	Units
$V_{DD}/V_{DDA}/V_{DDR}$	3.3 V Core Supply Voltage	3.3 V $\pm 5\%$	3.135	3.465	V
V_{DD_IO} (Note 2)	I/O Supply Voltage	1.05 V to 3.3 V $\pm 5\%$	0.975	3.465	V
I_{DD}	Power Supply Current NB3N1200K NB3W1200L	At 133 MHz, $C_L = 2\text{ pF}$		330 180	mA
I_{DDPD}	Power Down Current NB3N1200K NB3W1200L			6 6	mA
V_{IH} (Note 3)	Input High Voltage, Single-Ended Inputs		2.0	5.5	V
V_{IL} (Note 3)	Input Low Voltage, Single-Ended Inputs		GND-0.3	0.8	V
V_{IHCLK_IN}	CLK_IN/CLK_IN# High		600	1150	mV
V_{ILCLK_IN}	CLK_IN/CLK_IN# Low		-300	300	mV
I_{IL} (Note 4)	Input Leakage Current	$0 < V_{IN} < V_{DD}$	-5	+5	μA
V_{IH_FS} (Note 5)	Input High Voltage		0.7	$V_{DD}+0.3$	V
V_{IL_FS} (Note 5)	Input Low Voltage		GND-0.3	0.35	V
V_{IL_Tri} (Note 6)	Tri-Level Input Low Voltage		0	0.8	V
V_{IM_Tri} (Note 6)	Tri-Level Input Med Voltage		1.2	1.8	V
V_{IH_Tri} (Note 6)	Tri-Level Input High Voltage		2.2	V_{DD}	V
V_{OH} (Note 7)	Output High Voltage SCL, SDA	$I_{OH} = -1\text{ mA}$	2.4		V
V_{OL} (Note 7)	Output Low Voltage SCL, SDA	$I_{OL} = 1\text{ mA}$		0.4	V
C_{in} (Note 8)	Input Capacitance		2.5	4.5	pF
C_{out} (Note 8)	Output Capacitance		2.5	4.5	pF
L_{pin}	Pin Inductance			7	nH
t_a	Ambient Temperature	No Airflow	0	70	°C

2. V_{DD_IO} applies to the low power NMOS push-pull NB3W1200L only.

3. SDA, SCL, OEn#, PWRGD/PWRDN#.

4. Input Leakage Current does not include inputs with pull-up or pull-down resistors.

5. 100M_133M# Frequency Select (FS).

6. SA_0, SA_1, HBW_BYPASS_LBW#.

7. Signal edge is required to be monotonic when transitioning through this region.

8. Ccomp capacitance based on pad metallization and silicon device capacitance. Not including package pin capacitance.

NB3N1200K, NB3W1200L

NB3N1200K / NB3W1200L Output Relational Timing Parameters

Table 5. ELECTRICAL CHARACTERISTICS – Skew and Differential Jitter Parameters

($V_{DD} = V_{DDA} = V_{DDR} = 3.3\text{ V} \pm 5\%$, $T_A = 0 - 70^\circ\text{C}$)

Group	Description	Min	Typ	Max	Units
CLK_IN, DIF[x:0] (Notes 9, 10, 12, 13)	Input-to-Output Delay in PLL mode, nominal value	-100		100	ps
CLK_IN, DIF[x:0] (Notes 10, 11, 13)	Input-to-Output Delay in Bypass mode, nominal value	2.5		4.5	ns
CLK_IN, DIF[x:0] (Notes 10, 11, 13)	Input-to-Output Delay variation in PLL mode (over voltage and temperature), nominal value			100	ps
CLK_IN, DIF[x:0] (Notes 10, 11, 13)	Input-to-Output Delay variation in Bypass mode (over voltage and temperature), nominal value			250	ps
DIF[11:0] (Notes 9, 10, 11, 13)	Output-to-Output Skew across all 12 outputs (Common to Bypass and PLL mode)	0		50	ps

9. Measured into fixed 2 pF load capacitance. Input to output skew is measured at the first output edge following the corresponding input.
 10. Measured from differential cross-point to differential cross-point.
 11. All Bypass Mode Input-to-Output specs refer to the timing between an input edge and the specific output edge created by it.
 12. This parameter is deterministic for a given device.
 13. Measured with scope averaging on to find mean value.

NB3N1200K, NB3W1200L

Table 6. LOW BAND PHASE JITTER – PLL MODE

Group	Parameter	Min	Typ	Max	Units
DIF (Notes 14, 16, 17)	Output PCIe Gen1		13	86	ps (p-p)
DIF (Notes 14, 15, 17, 19)	Output PCIe Gen2 Low Band, 10 kHz < f < 1.5 MHz		0.1	3.0	ps RMS
DIF (Notes 14, 15, 17, 19)	Output PCIe Gen2 High Band, 1.5 MHz < f < 50 MHz		0.8	3.1	ps RMS

HIGH BAND, 1.5 MHz < F < Nyquist

DIF (Notes 14, 15, 17, 19)	Output phase jitter impact – PCIe* Gen3 (including PLL BW 2 – 4 MHz, CDR = 10 MHz)		0.18	1.0	ps RMS
DIF (Notes 14, 15, 17, 19)	Output phase jitter impact – PCIe* Gen4 (including PLL BW 2 – 4 MHz, CDR = 10 MHz)		0.18	0.5	ps RMS
DIF (Notes 14, 18)	Output Intel UPI intermediate frequency accumulated jitter (9.6 Gb/s, 10.4 Gb/s or 11.2 Gb/s, 100 MHz, 12 UI)		0.5	1.0	ps RMS
DIF (Notes 14, 18, 20)	Output Intel QPI & Intel SMI REFCLK accumulated jitter (4.8 Gb/s or 6.4 Gb/s, 100 MHz or 133 MHz, 12 UI)		0.14	0.5	ps RMS
DIF (Notes 14, 18)	Output Intel QPI & Intel SMI REFCLK accumulated jitter (8 Gb/s, 100 MHz, 12 UI)		0.07	0.3	ps RMS
DIF (Notes 14, 18)	Output Intel QPI & Intel SMI REFCLK accumulated jitter (9.6 Gb/s, 100 MHz, 12 UI)		0.06	0.2	ps RMS

Table 7. ADDITIVE PHASE JITTER – BYPASS MODE

Group	Parameter	Min	Typ	Max	Units
DIF (Notes 14, 16, 17)	Output PCIe Gen1		0.04	10	ps (p-p)
DIF (Notes 14, 15, 17, 19)	Output PCIe Gen2 Low Band, 10 kHz < f < 1.5 MHz		0.001	0.3	ps RMS
DIF (Notes 14, 15, 17, 19)	Output PCIe Gen2 High Band, 1.5 MHz < f < 50 MHz		0.002	0.7	ps RMS
DIF (Notes 14, 15, 17, 19)	Output phase jitter impact – PCIe* Gen3		0.001	0.3	ps RMS
DIF (Notes 14, 15, 17, 19)	Output phase jitter impact – PCIe* Gen4		0.001	0.3	ps RMS
DIF (Notes 14, 18, 20)	Output Intel QPI & Intel SMI REFCLK accumulated jitter (4.8 Gb/s or 6.4 Gb/s, 100 MHz or 133 MHz, 12 UI)		0.001	0.3	ps RMS
DIF (Notes 14, 18)	Output Intel QPI & Intel SMI REFCLK accumulated jitter (8 Gb/s, 100 MHz, 12 UI)		0.001	0.1	ps RMS
DIF (Notes 14, 18)	Output Intel QPI & Intel SMI REFCLK accumulated jitter (9.6 Gb/s, 100 MHz, 12 UI)		0.001	0.1	ps RMS

14. Post processed evaluation through Intel supplied Matlab scripts. Tested with NB3N1200K/NB3W1200L driven by a CK420BQ or equivalent.

15. PCIe Gen4 filter characteristics are subject to final ratification by PCISIG. Please check the PCI SIG for the latest specification.

16. These jitter numbers are defined for a BER of 1E-12. Measured numbers at a smaller sample size have to be extrapolated to this BER target.

17. $\gamma = 0.54$ is implying a jitter peaking of 3 dB.

18. Measuring on 100 MHz output using Intel supplied clock template jitter tool.

19. Measuring on 100 MHz PCIe SRC output using Intel supplied clock jitter tool.

20. Measuring on 100 MHz, 133 MHz output using Intel supplied clock jitter tool.

Table 8. PLL BANDWIDTH AND PEAKING

Group	Parameter	Min	Typ	Max	Units
DIF (Note 21)	PLL Jitter Peaking (HBW_BYPASS_LBW# = 0)	–	0.7	2.0	dB
DIF (Note 21)	PLL Jitter Peaking (HBW_BYPASS_LBW# = 1)	–	0.4	2.5	dB
DIF (Note 22)	PLL Bandwidth (HBW_BYPASS_LBW# = 1)	2.0	2.7	4.0	MHz
DIF (Note 22)	PLL Bandwidth (HBW_BYPASS_LBW# = 0)	0.7	0.9	1.4	MHz

21. Measured as maximum pass band gain. At frequencies within the loop BW, highest point of magnification is called PLL jitter peaking.

22. Measured at 3 db down or half power point.

NB3N1200K, NB3W1200L

Table 9. DIF 0.7 V AC TIMING CHARACTERISTICS (Non-Spread or -0.5% Spread Spectrum Mode)

($V_{DD} = V_{DDA} = V_{DDR} = 3.3 \text{ V} \pm 5\%$)

Symbol	Parameter	CLK = 100 MHz, 133.33 MHz		Unit	
		Min	Max		
Tstab (Note 44)	Clock Stabilization Time		1.8	ms	
Laccuracy (Notes 26, 30, 38, 45)	Long Accuracy		100	ppm	
Tabs (Notes 26, 27, 30)	Absolute Min/Max Host CLK Period	No Spread	9.94900 for 100 MHz	10.05100 for 100 MHz	ns
			7.44925 for 133 MHz	7.55075 for 133 MHz	
		-0.5% Spread	9.49900 for 100 MHz	10.10126 for 100 MHz	
			7.44925 for 133 MHz	7.58845 for 133 MHz	
Slew_rate (Notes 24, 26, 30)	DIFF OUT Slew_rate (see Figure 4)	1.0	4.0	V/ns	
Δ Trise / Δ Tfall (Notes 26, 29, 40)	Rise and Fall Time Variation		125	ps	
Rise/Fall Matching (Notes 26, 30, 41, 43)			20	%	
VHigh (Notes 26, 29, 32)	Voltage High (typ 0.70 Volts)	660	850	mV	
VLow (Notes 26, 29, 33)	Voltage Low (typ 0.0 Volts)	-150	150	mV	
Vmax (Note 29)	Maximum Voltage		1150	mV	
Vcross absolute (Notes 23, 25, 26, 29, 36)	Absolute Crossing Point Voltages	250	550	mV	
Vcross relative (Notes 26, 28, 29, 36)	Relative Crossing Point Voltages	Calc	Calc		
Total Δ Vcross (Notes 26, 29, 37)	Total Variation of Vcross Over All Edges		140	mV	
Tccjitter (Notes 26, 30, 42)	Cycle-to-Cycle Jitter		50	ps	
Duty Cycle (Notes 26, 30)	PLL and Bypass Modes	45	55	%	
tOE# Latency	OE# Latency – DIFF start after OE# Assertion – DIFF stop after OE# Deassertion	4	12	Clocks	
Vovs (Notes 26, 29, 34)	Maximum Voltage (Overshoot)		Vhigh + 0.3	V	
Vuds (Notes 26, 29, 35)	Maximum Voltage (Undershoot)		Vlow - 0.3	V	
Vrb (Notes 26, 29)	Ringback Voltage	0.2	N/A	V	

23. Measured at crossing point where the instantaneous voltage value of the rising edge of CLK equals the falling edge of CLK#.
24. Measurement taken from differential waveform on a component test board. The slew rate is measured from -150 mV to +150 mV on the differential waveform. Scope is set to average because the scope sample clock is making most of the dynamic wiggles along the clock edge. Only valid for Rising CLK_IN and Falling CLK_IN#. Signal must be monotonic through the Vol to Voh region for Trise and Tfall.
25. This measurement refers to the total variation from the lowest crossing point to the highest, regardless of which edge is crossing.
26. Test configuration is $R_s = 33.2 \Omega$, $R_p = 49.9$, 2 pF for 100Ω transmission line; $R_s = 27 \Omega$, $R_p = 42.2$, 2 pF for 85Ω transmission line.
27. The average period over any $1 \mu\text{s}$ period of time must be greater than the minimum and less than the maximum specified period.
28. Vcross(rel) Min and Max are derived using the following, Vcross(rel) Min = $0.250 + 0.5 (V_{\text{havg}} - 0.700)$, Vcross(rel) Max = $0.550 - 0.5 (0.700 - V_{\text{havg}})$, (see Figure 7).
29. Measurement taken from Single Ended waveform.
30. Measurement taken from differential waveform. Bypass mode, input duty cycle = 50%.
31. Unless otherwise noted, all specifications in this table apply to all processor frequencies.
32. VHigh is defined as the statistical average High value as obtained by using the Oscilloscope VHigh Math function.
33. VLow is defined as the statistical average Low value as obtained by using the Oscilloscope VLow Math function.
34. Overshoot is defined as the absolute value of the maximum voltage.
35. Undershoot is defined as the absolute value of the minimum voltage.
36. The crossing point must meet the absolute and relative crossing point specifications simultaneously.
37. Δ Vcross is defined as the total variation of all crossing voltages of Rising DIFF and Falling DIFF#. This is the maximum allowed variance in Vcross for any particular system.
38. Using frequency counter with the measurement interval equal or greater than 0.15 s, target frequencies are 100,000,000 Hz, 133,333,333 Hz.
39. Using frequency counter with the measurement interval equal or greater than 0.15 s, target frequencies are 99,750,00 Hz, 133,000,000 Hz.
40. Measured with oscilloscope, averaging off, using min max statistics. Variation is the delta between min and max.
41. Measured with oscilloscope, averaging on, The difference between the rising edge rate (average) of DIFF versus the falling edge rate (average) of DIFF#. Measured in a $\pm 75 \text{ mV}$ window around the crosspoint of DIFF and DIFF#.
42. Measured with device in PLL mode, in BYPASS mode jitter is additive.
43. Rise/Fall matching is derived using the following, $2^*(\text{Trise} - \text{Tfall}) / (\text{Trise} + \text{Tfall})$.
44. This is the time from the valid CLK_IN input clocks and the assertion of the PWRGD signal level at 1.8 V - 2.0 V to the time that stable clocks are output from the buffer chip (PLL locked).
45. All Long Term Accuracy specifications are guaranteed with the assumption that the input clock complies with CK410B+/CK420BQ accuracy requirements. The NB3N1200K and NB3W1200L itself do not contribute to ppm error.

NB3N1200K, NB3W1200L

Table 10. CLOCK PERIOD SSC DISABLED

SSC OFF Center Freq. MHz	Measurement Window							Units
	1 Clock	1 μ s	0.1 s	0.1 s	0.1 s	1 μ s	1 Clock	
	- Jitter c-c Abs Per Min	- SSC Short Avg Min	- ppm Long Avg Min	0 ppm Period	+ ppm Long Avg Max	+ SSC Short Avg Max	+ Jitter c-c Abs Per Max	
100.00	9.94900		9.99900	10.00000	10.00100		10.05100	ns
133.33	7.44925		7.49925	7.50000	7.50075		7.55075	ns

Table 11. CLOCK PERIOD SSC ENABLED

SSC ON Center Freq. MHz	Measurement Window							Units
	1 Clock	1 μ s	0.1 s	0.1 s	0.1 s	1 μ s	1 Clock	
	- Jitter c-c Abs Per Min	- SSC Short Avg Min	- ppm Long Avg Min	0 ppm Period	+ ppm Long Avg Max	+ SSC Short Avg Max	+ Jitter c-c Abs Per Max	
99.75	9.94900	9.99900	10.02406	10.02506	10.02607	10.05126	10.10126	ns
133.00	7.44925	7.49925	7.51805	7.51880	7.51955	7.53845	7.58845	ns

Table 12. INPUT EDGE RATE (Note 46)

Frequency Select (FS)	Min	Max	Unit
100 MHz	0.35	N/A	V/ns
133 MHz	0.35	N/A	V/ns

46. Input edge rate is based on single ended measurement. This is the minimum input edge rate at which the NB3N1200K / NB3W1200L devices are guaranteed to meet all performance specifications.

NB3N1200K, NB3W1200L

Measurement Points for Differential

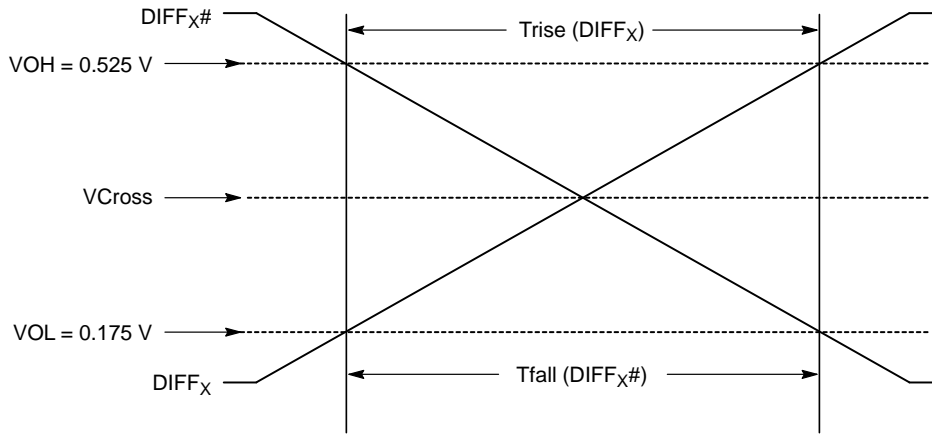

Figure 4. Single-Ended Measurement Points for Trise, Tfall

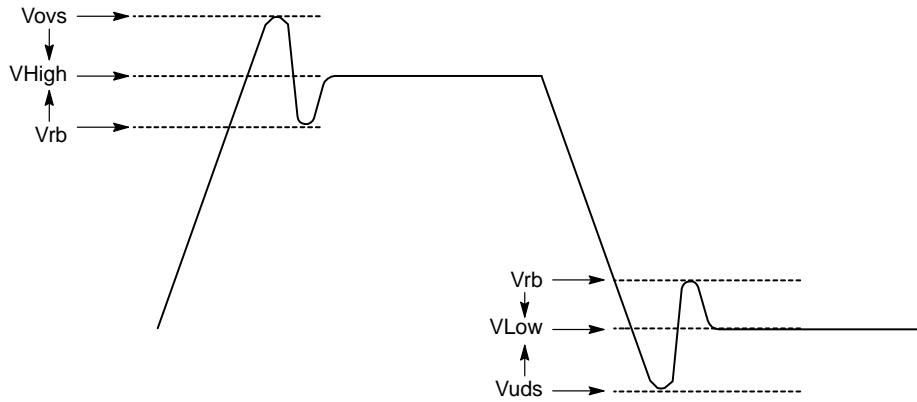

Figure 5. Single-Ended Measurement Points for Vovs, Vuds, Vrb

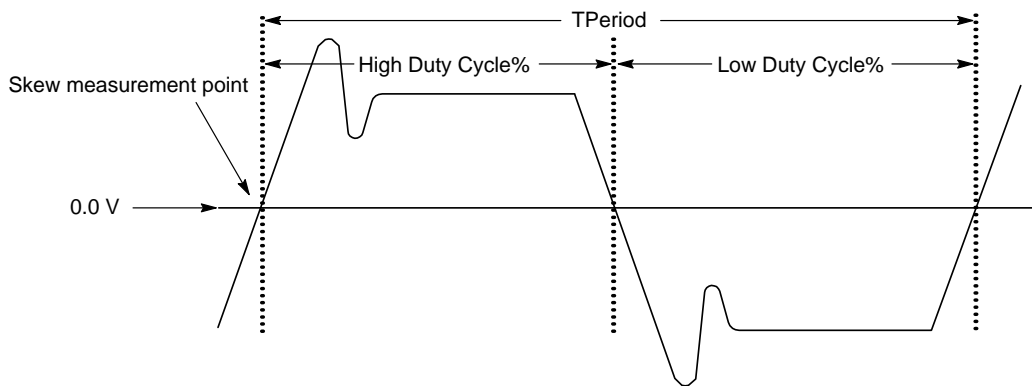
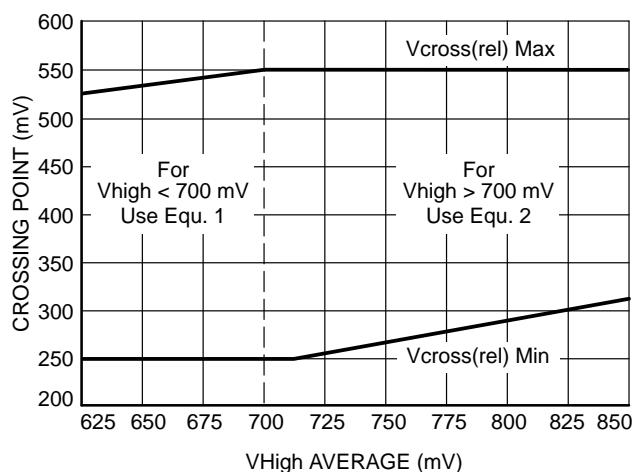

Figure 6. Differential ($DIFF_x - DIFF_{x\#}$) Measurement Points (Tperiod, Duty Cycle, Jitter)

NB3N1200K, NB3W1200L



Equ 1: $V_{cross(rel) Max} = 0.550 - 0.5(0.7 - V_{havg})$

Equ 2: $V_{cross(rel) Min} = 0.250 + 0.5(V_{havg} - 0.7)$

Figure 7. Vcross Range Clarification

The picture above illustrates the effect of V_{high} above and below 700 mV on the V_{cross} range. The purpose of this is to prevent a 250 mV V_{cross} with an 850 mV V_{high} . In addition, this prevents the case of a 550 mV V_{cross} with a 660 mV V_{high} . The actual specification for V_{cross} is dependent upon the measured amplitude of V_{high} .

CLK_IN, CLK_IN#

The differential input clock is expected to be sourced from a clock synthesizer.

OE# and Output Enables (Control Registers)

Each output can be individually enabled or disabled by SMBus control register bits. Additionally, each output of the DIF[11:0] has a dedicated OE# pin. The OE# pins are asynchronous asserted-low signals. The Output Enable bits in the SMBus registers are active high and are set to enable by default.

The disabled state for the NB3N1200K HCSL outputs is Hi-Z, with the termination network pulling the outputs Low/Low. The disabled state for the NB3W1200L low power NMOS Push-Pull outputs is Low/Low. In the following text, if the NB3N1200K HCSL output is referred to as Hi-Z or Tri- state, the equivalent state of the NB3W1200L NMOS Push-pull output is Low/Low.

Please note that the logic level for assertion or deassertion is different in software than it is on hardware. This follows hardware default nomenclature for communication channels (e.g., output is enabled if OE# pin is pulled low) and still maintains software programming logic (e.g., output is enabled if OE register is true).

Please refer to Table 13 for the truth table for enabling and disabling outputs via hardware and software. Note that both the control register bit must be a '1' AND the OE# pin must be a '0' for the output to be active.

NOTE: The assertion and de-assertion of this signal is absolutely asynchronous.

Table 13. NB3N1200K OE AND POWER MANAGEMENT

Inputs		OE# Hardware Pins & Control Register Bits			Outputs	PLL State
PWRGD/ PWRDN#	CLK_IN/ CLK_IN#	SMBUS Enable Bit	OE# Pin	DIF/DIF# [11:0]	FB_OUT/ FB_OUT#	
0	X	X	X	Hi-Z	Hi-Z	OFF
1	Running	0	X	Hi-Z	Running	ON
		1	0	Running	Running	ON
		1	1	Hi-Z	Running	ON

Table 14. NB3W1200L POWER MANAGEMENT

Inputs		OE# Hardware Pins & Control Register Bits			Outputs	PLL State
PWRGD/ PWRDN#	CLK_IN/ CLK_IN#	SMBUS Enable Bit	OE# Pin	DIF/DIF# [11:0]	NC pins (Pins 15, 16)	
0	X	X	X	Low/Low	Low/Low	OFF
1	Running	0	X	Low/Low	Running	ON
		1	0	Running	Running	ON
		1	1	Low/Low	Running	ON

NB3N1200K, NB3W1200L

OE# Assertion (Transition from '1' to '0')

All differential outputs that were tri-stated are to resume normal operation in a glitch free manner. The latency from the assertion to active outputs is 4 – 12 DIF clock periods.

OE# De-Assertion (Transition from '0' to '1')

The impact of de-asserting OE# is each corresponding output will transition from normal operation to tri-state in a glitch free manner. A minimum of 4 valid clocks will be provided after the de-assertion of OE#. The maximum latency from the de-assertion to tri-stated outputs is 12 DIF clock periods.

100M_133M# – Frequency Selection (FS)

The NB3N1200K / NB3W1200L is optimized for lowest phase jitter performance at 100 MHz and 133 MHz operating frequencies. The 100M_133M# is a hardware pin, which programs the appropriate output frequency of the DIF pairs. Note that the CLK_IN frequency is equal to CLK_OUT frequency; this means that the NB3N1200K / NB3W1200L is operated in the 1:1 mode only. The Frequency Selection can be enabled by the 100M_133M# hardware pin. An external pull-up or pull-down resistor is attached to this pin to select the input/output frequency. The functionality is summarized in Table 15.

Table 15. FREQUENCY SELECT (FS) PROGRAM

100M_133M#	Optimized Frequency (CLK_IN = CLK_OUT)
0	133.33 MHz
1	100.00 MHz

NOTE: All differential outputs transition from 100 MHz to 133 MHz or from 133 MHz to 100 MHz in a glitch free manner.

SA_0, SA_1 – Address Selection

SA_0 and SA_1 are tri-level hardware pins, which program the appropriate address for the NB3N1200K / NB3W1200L. The two tri-level input pins that can configure the NB3N1200K / NB3W1200L to nine different addresses (refer to Table 4 for VIL_Tri, VIM_Tri, VIH_Tri signal level).

Table 16. SMBUS ADDRESS TABLE

SA_1	SA_0	SMBUS Address
L	L	D8
L	M	DA
L	H	DE
M	L	C2
M	M	C4
M	H	C6
H	L	CA
H	M	CC
H	H	CE

PWRGD/PWRDN#

PWRGD/PWRDN# is a dual function pin. PWRGD is asserted high and de-asserted low. De-assertion of PWRGD (pulling the signal low) is equivalent to indicating a powerdown condition. PWRGD (assertion) is used by the NB3N1200K / NB3W1200L to sample initial configurations such as frequency select condition and SA selections.

After PWRGD has been asserted high for the first time, the pin becomes a PWRDN# (Power Down) pin that can be used to shut off all clocks cleanly and instruct the device to invoke power savings mode. PWRDN# is a completely asynchronous active low input. When entering power savings mode, PWRDN# should be asserted low **prior to shutting off the input clock or power** to ensure all clocks shut down in a glitch free manner. When PWRDN# is asserted low by two consecutive rising edges of DIF#, all differential outputs are held tri-stated on the next DIF# high to low transition. The assertion and de-assertion of PWRDN# is absolutely asynchronous.

WARNING: Disabling of the CLK_IN input clock prior to assertion of PWRDN# is an undefined mode and not recommended. Operation in this mode may result in glitches, excessive frequency shifting, etc.

Table 17. PWRGD/PWRDN# FUNCTIONALITY

PWRGD/PWRDN#	DIF	DIF#
0	Tri-state	Tri-state
1	Running	Running

Buffer Power-Up State Machine

Table 18. BUFFER POWER-UP STATE MACHINE

State	Description
0	3.3 V Buffer power off
1	After 3.3 V supply is detected to rise above 3.135 V, the buffer enters State 1 and initiates a 0.1 ms–0.3 ms delay.
2	Buffer waits for a valid clock on the CLK input and PWRDN# de-assertion (or PWRGD assertion low to high)
3	Once the PLL is locked to the CLK_IN input clock, the buffer enters state 3 and enables outputs for normal operation. (Notes 47, 48)

47. The total power up latency from power on to all outputs active must be less than 1.8 ms (assuming a valid clock is present on CLK_IN input).
 48. If power is valid and powerdown is de-asserted (PWRGD asserted) but no input clocks are present on the CLK_IN input, DIF clocks must remain disabled. Only after valid input clocks are detected, valid power, PWRDN# de-asserted (PWRGD asserted) with the PLL locked/stable and the DIF outputs enabled.

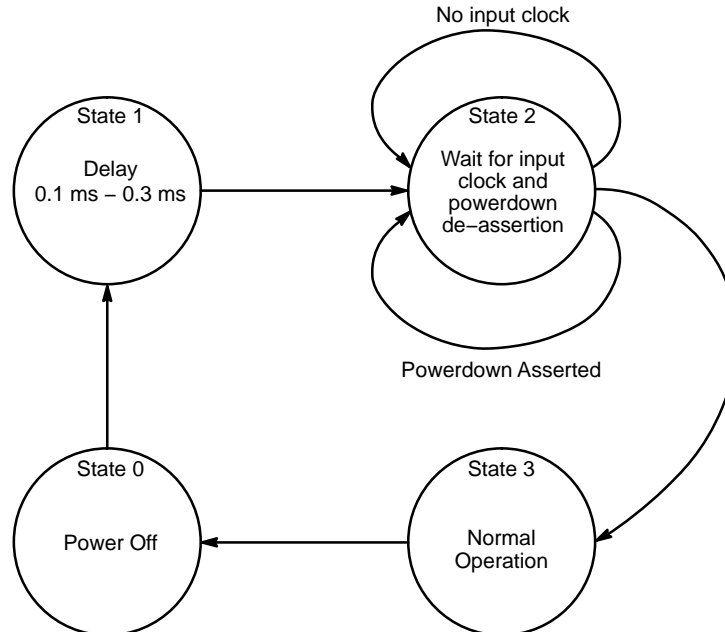

Figure 8. Buffer Power-Up State Diagram

Device Power-Up Sequence

Follow the power-up sequence below for proper device functionality:

1. PWRGD/PWRDN# pin must be Low.
2. Assign remaining control pins to their required state (100M_133M#, HBW_BYPASS_LBW#, SDA, SCL)

3. Apply power to the device.
4. Once the VDD pin has reached a valid VDDmin level (3.3V -5%), the PWRGD/PWRDN# pin must be asserted High. See Figure 9.

Note: If no clock is present on the CLK_IN/CLK_IN# pins when device is powered up, there will be no clock on DIF/DIF# outputs.

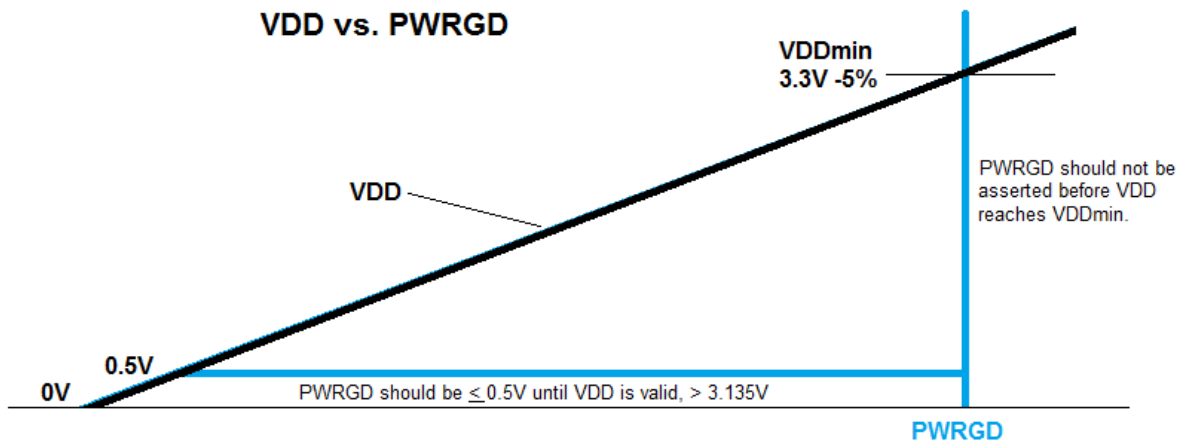

Figure 9. PWRGD and VDD Relationship Diagram

NB3N1200K, NB3W1200L

PWRDN# Assertion

When PWRDN# is sampled low by two consecutive rising edges of DIF#, all differential outputs must held tri-stated on the next DIF# high to low transition.

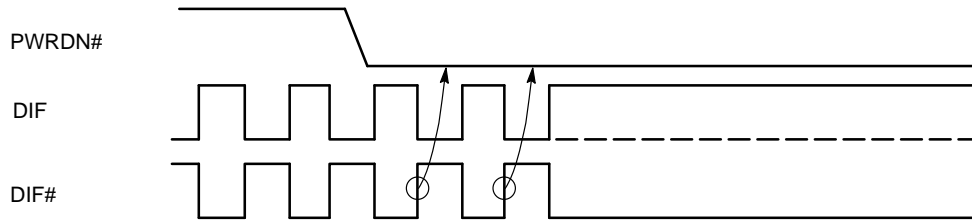

Figure 10. PWRDN#—Assertion

PWRGD Assertion

The power-up latency is to be less than 1.8 ms. This is the time from the valid CLK_IN input clocks and the assertion of the PWRGD signal to the time that stable clocks are output from the buffer chip (PLL locked). All differential

outputs stopped in a tri-state condition resulting from power down must be driven high in less than 300 μs of PWRDN# de-assertion to a voltage greater than 200 mV.

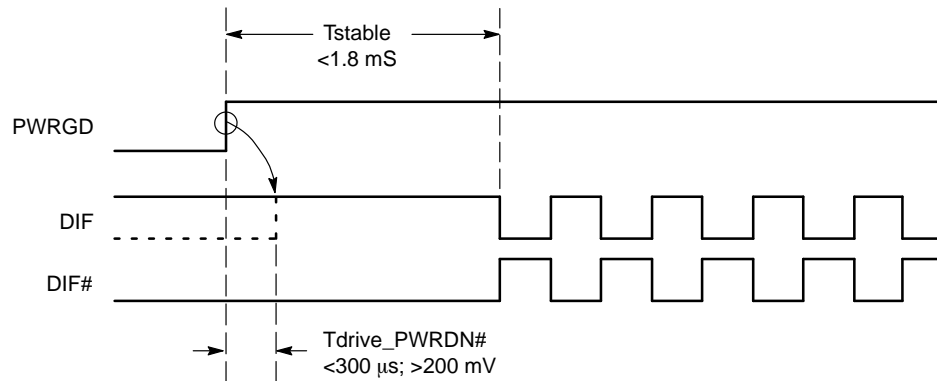

Figure 11. PWRGD Assertion (Pwrdown - De-assertion)

HBW_BYPASS_LBW#

The HBW_BYPASS_LBW# is a tri level function input pin (refer to Table 13 for VIL_Tri, VIM_Tri, VIH_Tri—signal level). It is used to select between PLL high bandwidth, bypass mode and PLL low bandwidth mode. In the bypass mode, the input clock is passed directly to the output stage which may result in up to 50 ps of additive

cycle-to-cycle jitter (50 ps + input jitter) on DIF outputs. In the case of PLL mode, the input clock is passed through a PLL to reduce high frequency jitter. The PLL HBW, BYPASS, and PLL LBW mode may be selected by asserting the HBW_BYPASS_LBW# input pin to the appropriate level per the following table:

Table 19. PLL BANDWIDTH AND READBACK TABLE

HBW_BYPASS_LBW# Pin	Mode	Byte 0, Bit 7	Byte 0, Bit 6
L	LBW	0	0
M	BYPASS	0	1
H	HBW	1	1

Additionally, the NB3N1200K/NB3W1200L has the ability to override the Latch value of the PLL operating mode from hardware strap pin 5 via use of Byte 0, bits 2 and 1. Byte 0 Bit 3 must be set to 1 to allow user to change Bits

2 and 1 to affect the PLL. Bits 7 and 6 will always read back the original latched value. A warm reset of the system will have to be accomplished if the user changes these bits.

NB3N1200K, NB3W1200L

External Feedback Termination

NB3N1200K External Feedback Termination

The NB3N1200K utilizes fixed external feedback topology to achieve low input-to-output delay variation. A normal HCSL termination will be needed on the FB_OUT/FB_OUT# pin 15 and pin 16. A combined shunt and series resistors value can be used to form a single termination resistor for the R_{FB_term} .

The termination resistor value is the sum of the R_s and R_p values.

For 100 Ω trace impedance line:

$$R_s = 33 \Omega; R_p = 49.9 \Omega$$

$$\text{Therefore, } R_{FB_term} = 82.9 \Omega$$

NOTE: Use the standard 82.5 Ω , 1% resistor value.

For 85 Ω trace impedance line:

$$R_s = 27 \Omega; R_p = 43.2 \Omega$$

$$\text{Therefore, } R_{FB_term} = 70.2 \Omega$$

NOTE: Use the standard 69.8 Ω , 1% resistor value.

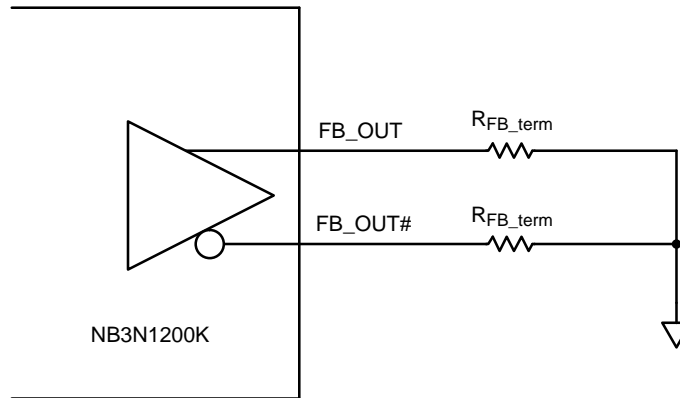

Figure 12. External Feedback Example Schematic

Table 20. FEEDBACK TERMINATION RESISTORS

Board Trace Impedance	R_{FB_term}	Units
100	82.5 1%	Ω
85	69.8 1%	Ω

NB3W1200L Feedback Termination

There is no termination resistor needed at pin 15 and pin 16 of the NB3W1200L NMOS push-pull low power buffer. Pin 15 and pin 16 of the NB3W1200L are no connect (NC) pins. These pins have an active signal on them, so they MUST be left unconnected.

NB3N1200K, NB3W1200L

Byte Read/Write

Reading or writing a register in a SMBus slave device in byte mode always involves specifying the register number.

Read. The standard byte read is as shown in the following figure. It is an extension of the byte write. The write start condition is repeated then the slave device starts sending

data and the master acknowledges it until the last byte is sent. The master terminates the transfer with a NAK, then a stop condition. For byte operation, the 2*7th bit of the command byte must be set. For block operations, the 2*7th bit must be reset. If the bit is not set, the next byte must be the byte transfer count.

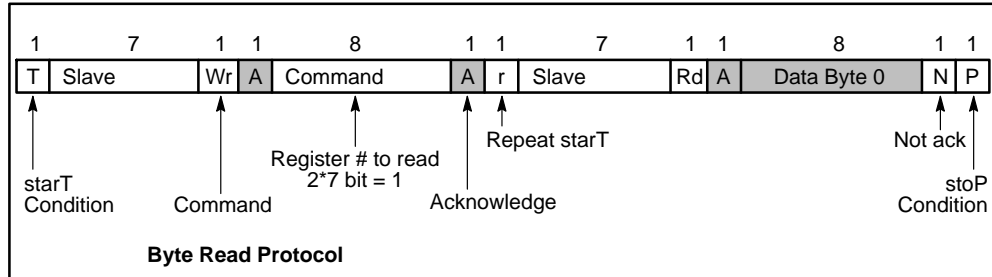

Figure 13. Byte Read Protocol

Write. The following figure illustrates a simple typical byte write. For byte operation the 2*7th bit of the command byte must be set. For block operations, the 2*7th bit must be reset.

If the bit is not set, the next byte must be the byte transfer count. The count can be between 1 and 32. It is not allowed to be zero or exceed 32.

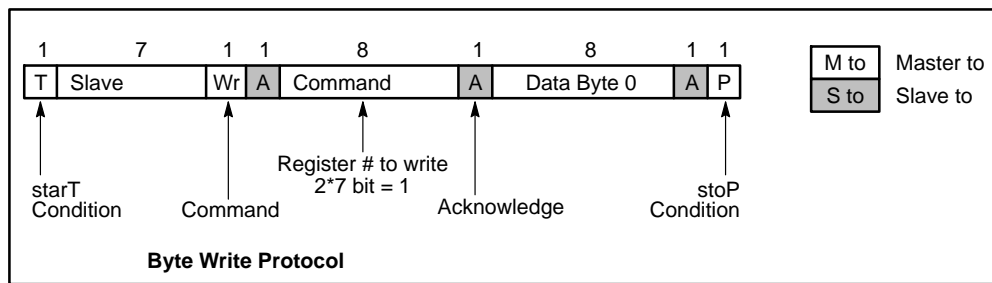

Figure 14. Byte Write Protocol

Block Read/Write

Read. After the slave address is sent with the r/w condition bit set, the command byte is sent with the MSB = 0. The slave Ack's the register index in the command byte. The master sends a repeat start function. After the slave Ack's this, the

slave sends the number of bytes it wants to transfer (>0 and <33). The master Ack's each byte except the last and sends a stop function.

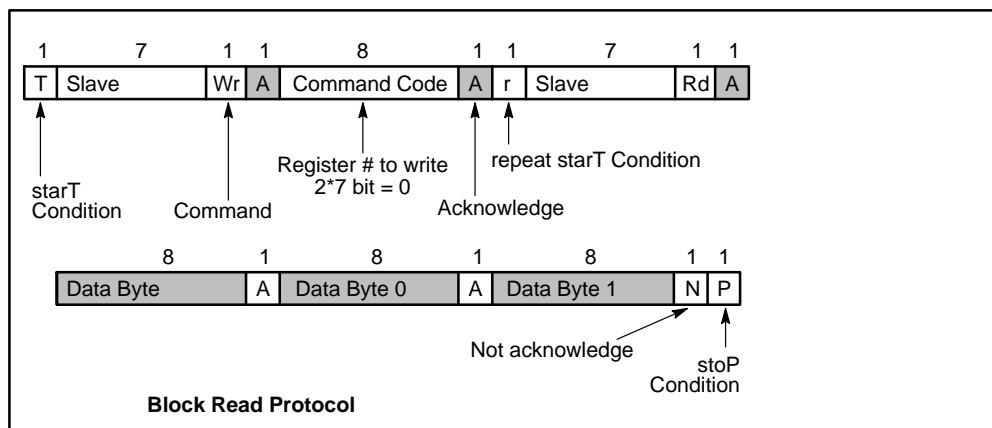

Figure 15. Block Read Protocol

NB3N1200K, NB3W1200L

Write. After the slave address is sent with the r/w condition bit not set, the command byte is sent with the MSB = 0. The lower seven bits indicate what register to start the transfer at. If the command byte is 00h, the slave device will be compatible with existing block mode slave devices. The next byte of a write must be the count of bytes that the master

will transfer to the slave device. The byte count must be greater than zero and less than 33. Following this byte are the data bytes to be transferred to the slave device. The slave device always acknowledges each byte received. The transfer is terminated after the slave sends the Ack and the master sends a stop function.

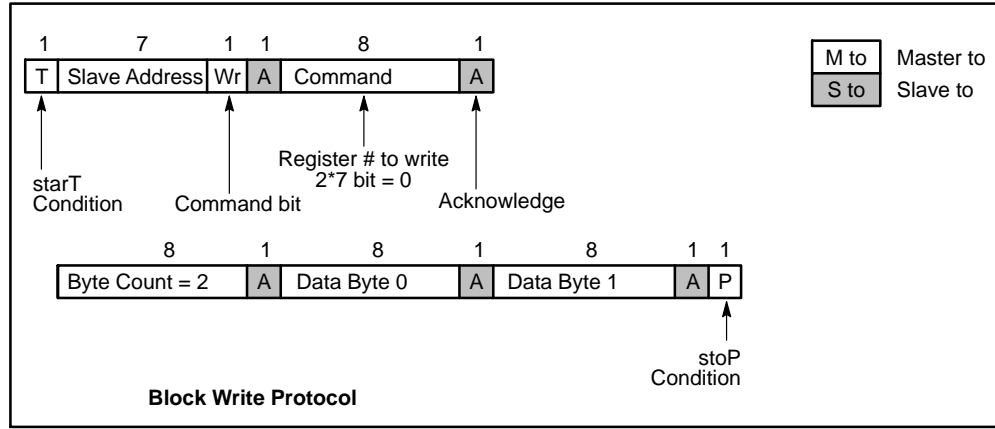

Figure 16. Block Write Protocol

NB3N1200K/NB3W1200L Control Register

Table 21. BYTE 0: FREQUENCY SELECT, OUTPUT ENABLE, PLL MODE CONTROL REGISTER

Bit	Description	If Bit = 0	If Bit = 1	Type	Default	Output(s) Affected
0	100M_133M# Frequency Select (FS)	133 MHz	100 MHz	R	Latched at power up	DIF[11:0]
1	PLL Mode 0	See PLL Operating Mode Readback Table		RW	1	
2	PLL Mode 1			RW	1	
3	PLL Software Enable	HW Latch	SMBUS Control	RW	0	
4	Reserved				0	
5	Reserved				0	
6	PLL Mode 0	See PLL Operating Mode Readback Table		R	Latched at power up	
7	PLL Mode 1	See PLL Operating Mode Readback Table		R	Latched at power up	

NOTE: Byte 0, bit_[3:1] are BW PLL SW enable for the NB3W1200L and NB3N1200K. Setting bit 3 to '1' allows the user to override the Latch value from pin 5 via use of bits 2 and 1. Use the values from the PLL Operating Mode Readback Table. Note that Bits 7 and 6 will keep the value originally latched on pin 5. A warm reset of the system will have to be accomplished if the user changes these bits.

NB3N1200K, NB3W1200L

Table 22. BYTE 1: OUTPUT ENABLE CONTROL REGISTER

Bit	Description	If Bit = 0	If Bit = 1	Type	Default	Output(s) Affected
0	Output Enable DIF 0	Hi-Z for NB3N1200K	Enabled	RW	1	DIF_0, DIF_0#
		Low/Low for NB3W1200L				
1	Output Enable DIF 1	Hi-Z for NB3N1200K	Enabled	RW	1	DIF_1, DIF_1#
		Low/Low for NB3W1200L				
2	Output Enable DIF 2	Hi-Z for NB3N1200K	Enabled	RW	1	DIF_2, DIF_2#
		Low/Low for NB3W1200L				
3	Output Enable DIF 3	Hi-Z for NB3N1200K	Enabled	RW	1	DIF_3, DIF_3#
		Low/Low for NB3W1200L				
4	Output Enable DIF 4	Hi-Z for NB3N1200K	Enabled	RW	1	DIF_4, DIF_4#
		Low/Low for NB3W1200L				
5	Output Enable DIF 5	Hi-Z for NB3N1200K	Enabled	RW	1	DIF_5, DIF_5#
		Low/Low for NB3W1200L				
6	Output Enable DIF 6	Hi-Z for NB3N1200K	Enabled	RW	1	DIF_6, DIF_6#
		Low/Low for NB3W1200L				
7	Output Enable DIF 7	Hi-Z for NB3N1200K	Enabled	RW	1	DIF_7, DIF_7#
		Low/Low for NB3W1200L				

Table 23. BYTE 2: OUTPUT ENABLE CONTROL REGISTER

Bit	Description	If Bit = 0	If Bit = 1	Type	Default	Output(s) Affected
0	Output Enable DIF 8	Hi-Z for NB3N1200K	Enabled	RW	1	DIF_8, DIF_8#
		Low/Low for NB3W1200L				
1	Output Enable DIF 9	Hi-Z for NB3N1200K	Enabled	RW	1	DIF_9, DIF_9#
		Low/Low for NB3W1200L				
2	Output Enable DIF 10	Hi-Z for NB3N1200K	Enabled	RW	1	DIF_10, DIF_10#
		Low/Low for NB3W1200L				
3	Output Enable DIF 11	Hi-Z for NB3N1200K	Enabled	RW	1	DIF_11, DIF_11#
		Low/Low for NB3W1200L				
4	Reserved					
5	Reserved					
6	Reserved					
7	Reserved					

NB3N1200K, NB3W1200L

Table 24. BYTE 3: OE_[7:0]# PINS REALTIME READBACK CONTROL REGISTER

Bit	Description	If Bit = 0	If Bit = 1	Type	Default	Output(s) Affected
0	Reserved				0	
1	Reserved				0	
2	Reserved				0	
3	Reserved				0	
4	Reserved				0	
5	Reserved				0	
6	Reserved				0	
7	Reserved				0	

Table 25. BYTE 4: OE_[11:8]# PINS REALTIME READBACK CONTROL REGISTER

Bit	Description	If Bit = 0	If Bit = 1	Type	Default	Output(s) Affected
0	Reserved				0	
1	Reserved				0	
2	Reserved				0	
3	Reserved				0	
4	Reserved				0	
5	Reserved				0	
6	Reserved				0	
7	Reserved				0	

Table 26. BYTE 5: VENDOR/REVISION IDENTIFICATION CONTROL REGISTER

Bit	Description	If Bit = 0	If Bit = 1	Type	Default	
0	Vendor ID Bit 0	1111 = ON Semiconductor		R	1	Vendor ID
1	Vendor ID Bit 1			R	1	
2	Vendor ID Bit 2			R	1	
3	Vendor ID Bit 3			R	1	
4	Revision Code Bit 0	0011		R	X	Revision Code
5	Revision Code Bit 1			R	X	
6	Revision Code Bit 2			R	X	
7	Revision Code Bit 3			R	X	

NB3N1200K, NB3W1200L

Table 27. BYTE 6: DEVICE ID CONTROL REGISTER

Bit	Description	If Bit = 0	If Bit = 1	Type	1200K	1200L
0	Device ID 0	1200K = 120d = 78hex 1200L = 130d = 82hex		R	0	0
1	Device ID 1			R	0	1
2	Device ID 2			R	0	0
3	Device ID 3			R	1	0
4	Device ID 4			R	1	0
5	Device ID 5			R	1	0
6	Device ID 6			R	1	0
7	Device ID 7 (MSB)			R	0	1

Table 28. BYTE 7: BYTE COUNT REGISTER

Bit	Description	If Bit = 0	If Bit = 1	Type	Default	
0	BC0 – Writing to this register configures how many bytes will be read back			RW	0	
1	BC1 – Writing to this register configures how many bytes will be read back			RW	0	
2	BC2 – Writing to this register configures how many bytes will be read back			RW	0	
3	BC3 – Writing to this register configures how many bytes will be read back			RW	1	
4	BC4 – Writing to this register configures how many bytes will be read back			RW	0	
5	Reserved					0
6	Reserved					0
7	Reserved					0

Table 29. BYTE 8 AND BEYOND: VENDOR SPECIFIC

Bit	Description	If Bit = 0	If Bit = 1	Type	Default	
0	Reserved					0
1	Reserved					0
2	Reserved					0
3	Reserved					0
4	Reserved					0
5	Reserved					0
6	Reserved					0
7	Reserved					0

NB3N1200K, NB3W1200L

Table 30. DIF CLOCK OUTPUT CURRENT

Board Target Trace/Term Z	Reference R, $I_{ref} = V_{DD}/(3 \cdot R_r)$	Output Current	$V_{OH} @ Z$
100 Ω	$R_{REF} = 475 \Omega$ 1%, $I_{ref} = 2.32 \text{ mA}$	$I_{OH} = 6 \cdot I_{ref}$	0.7 V @ 50 Ω
85 Ω	$R_{REF} = 412 \Omega$, 1%, $I_{ref} = 2.67 \text{ mA}$	$I_{OH} = 6 \cdot I_{ref}$	0.7 V @ 43.2 Ω

NMOS Push-Pull Buffer Specifications for NB3W1200L

Low Power NMOS Push-Pull Differential Buffer

The NB3W1200L utilizes the low-power output buffer for all differential clocks. This buffer uses efficient NMOS

push-pull drivers powered off a low voltage rail, offering a reduction in power consumption, improved edge rate performance, and cross point voltage control.

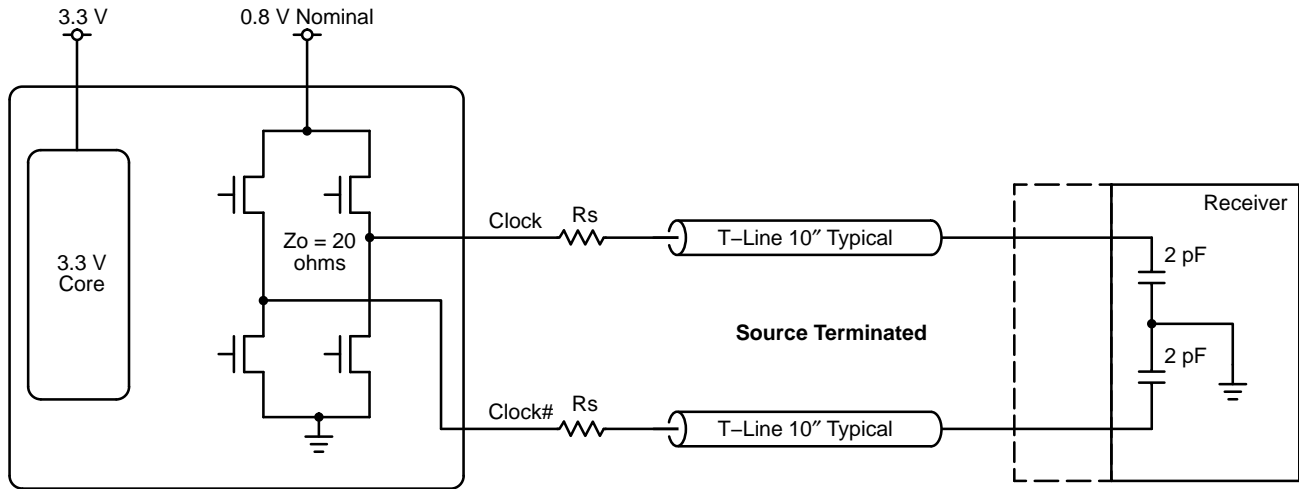

Figure 17. NMOS Push-Pull Buffer Diagram

Power Filtering Example

Ferrite Bead Power Filtering

Recommended ferrite bead filtering equivalent to the following:

600 Ω impedance at 100 MHz, $\leq 0.1 \Omega$ DCR max., $\geq 400 \text{ mA}$ current rating.

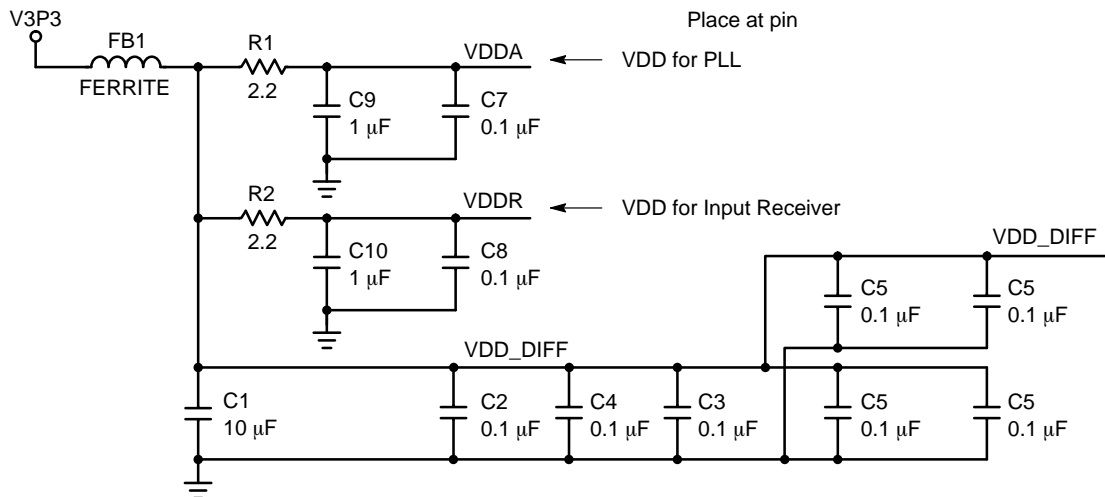

Figure 18. Schematic Example of the NB3N1200K / NB3W1200L Power Filtering

NB3N1200K, NB3W1200L

Termination of Differential Outputs

Table 31. NB3N1200K RESISTIVE LUMPED TEST LOADS FOR DIFFERENTIAL CLOCKS

Clock	Board Trace Impedance	R_s	R_p	R_{Iref}	Units
DIFF Clocks – 50 Ω configuration	100	33 5%	49.9 1%	475 1%	Ω
DIFF Clocks – 43 Ω configuration	85	27 5%	42.2 1%	412 1%	Ω

Table 32. NB3W1200L RESISTIVE LUMPED TEST LOADS FOR DIFFERENTIAL CLOCKS

Clock	Board Trace Impedance	R_s	R_p	R_{Iref}	Units
DIFF Clocks – 50 Ω configuration	100	33 5%	N/A	N/A	Ω
DIFF Clocks – 43 Ω configuration	85	27 5%	N/A	N/A	Ω

Termination of Differential HCSL Type Outputs (NB3N1200K)

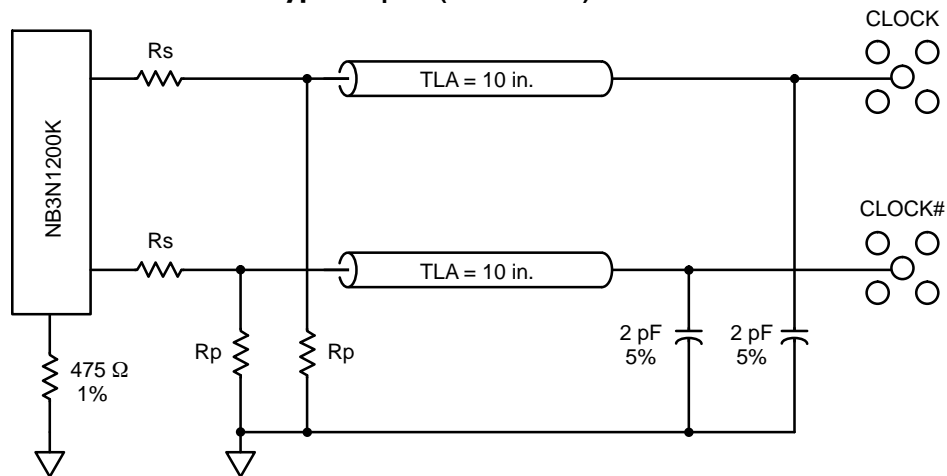

Figure 19. 0.7 V Configuration Test Load Board Termination for HCSL NB3N1200K

Termination of Differential NMOS Push– Pull Type Outputs (NB3W1200L)

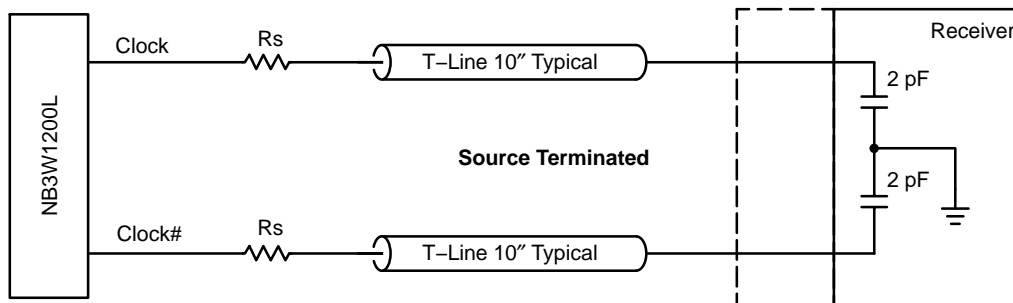

Figure 20. 0.7 V Configuration Test Load Board Termination for NMOS Push–Pull NB3W1200L

MECHANICAL CASE OUTLINE

PACKAGE DIMENSIONS

ON Semiconductor®



QFN64 9x9, 0.5P (PUNCH & SAWN) CASE 485DH ISSUE O

DATE 27 AUG 2013

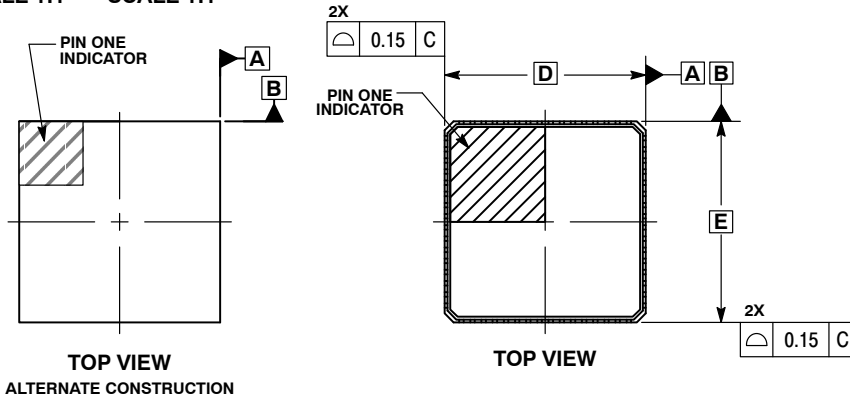
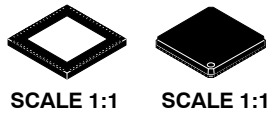

NOTES:

1. DIMENSIONING AND TOLERANCING PER ASME Y14.5M, 1994.
2. CONTROLLING DIMENSIONS: MILLIMETERS.
3. DIMENSION b APPLIES TO PLATED TERMINAL AND IS MEASURED BETWEEN 0.15 AND 0.25mm FROM THE TERMINAL TIP COPLANARITY APPLIES TO THE EXPOSED PAD AS WELL AS THE TERMINALS.
4. ALL DIMENSIONS APPLY TO BOTH THE SAWN AND PUNCH PACKAGES.

MILLIMETERS		
DIM	MIN	MAX
A	0.80	1.00
A1	0.00	0.05
A3	0.20	REF
b	0.18	0.30
D	9.00	BSC
D2	5.90	6.25
E	9.00	BSC
E2	5.90	6.25
e	0.50	BSC
L	0.30	0.50
L1	0.00	0.15

GENERIC MARKING DIAGRAM*

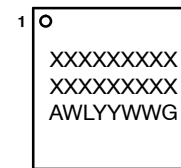

XXXXX = Specific Device Code
 A = Assembly Location
 WL = Wafer Lot
 YY = Year
 WW = Work Week
 G = Pb-Free Package

*This information is generic. Please refer to device data sheet for actual part marking.

Pb-Free indicator, "G" or microdot "•", may or may not be present.

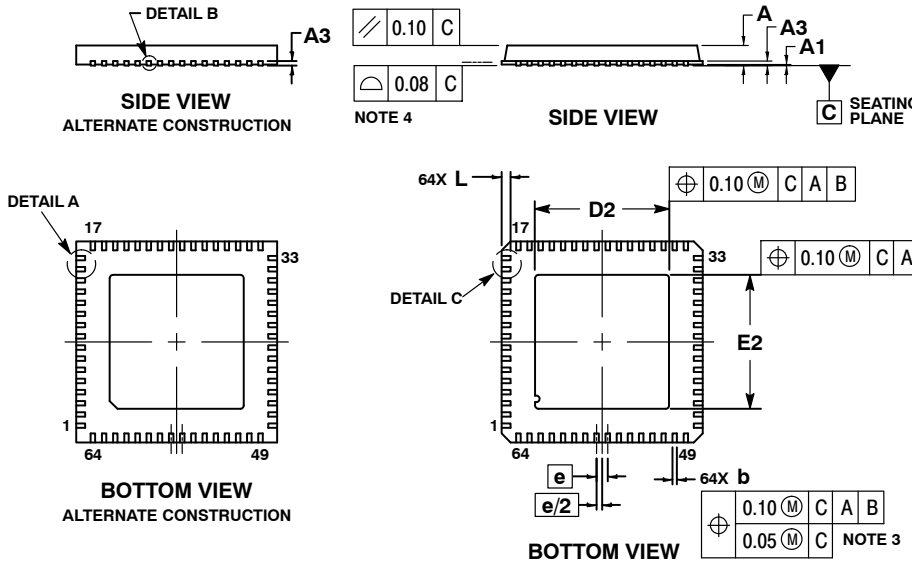

RECOMMENDED SOLDERING FOOTPRINT

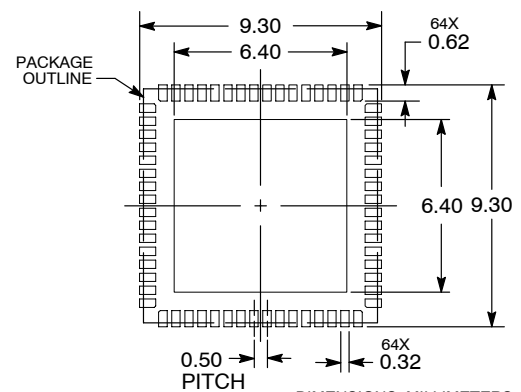

DOCUMENT NUMBER:	98AON77431F	Electronic versions are uncontrolled except when accessed directly from the Document Repository. Printed versions are uncontrolled except when stamped "CONTROLLED COPY" in red.
DESCRIPTION:	QFN64 9x9, 0.5P (PUNCH & SAWN)	PAGE 1 OF 1

ON Semiconductor and are trademarks of Semiconductor Components Industries, LLC dba ON Semiconductor or its subsidiaries in the United States and/or other countries. ON Semiconductor reserves the right to make changes without further notice to any products herein. ON Semiconductor makes no warranty, representation or guarantee regarding the suitability of its products for any particular purpose, nor does ON Semiconductor assume any liability arising out of the application or use of any product or circuit, and specifically disclaims any and all liability, including without limitation special, consequential or incidental damages. ON Semiconductor does not convey any license under its patent rights nor the rights of others.

onsemi, **Onsemi**, and other names, marks, and brands are registered and/or common law trademarks of Semiconductor Components Industries, LLC dba "**onsemi**" or its affiliates and/or subsidiaries in the United States and/or other countries. **onsemi** owns the rights to a number of patents, trademarks, copyrights, trade secrets, and other intellectual property. A listing of **onsemi**'s product/patent coverage may be accessed at www.onsemi.com/site/pdf/Patent-Marking.pdf. **onsemi** reserves the right to make changes at any time to any products or information herein, without notice. The information herein is provided "as-is" and **onsemi** makes no warranty, representation or guarantee regarding the accuracy of the information, product features, availability, functionality, or suitability of its products for any particular purpose, nor does **onsemi** assume any liability arising out of the application or use of any product or circuit, and specifically disclaims any and all liability, including without limitation special, consequential or incidental damages. Buyer is responsible for its products and applications using **onsemi** products, including compliance with all laws, regulations and safety requirements or standards, regardless of any support or applications information provided by **onsemi**. "Typical" parameters which may be provided in **onsemi** data sheets and/or specifications can and do vary in different applications and actual performance may vary over time. All operating parameters, including "Typicals" must be validated for each customer application by customer's technical experts. **onsemi** does not convey any license under any of its intellectual property rights nor the rights of others. **onsemi** products are not designed, intended, or authorized for use as a critical component in life support systems or any FDA Class 3 medical devices or medical devices with a same or similar classification in a foreign jurisdiction or any devices intended for implantation in the human body. Should Buyer purchase or use **onsemi** products for any such unintended or unauthorized application, Buyer shall indemnify and hold **onsemi** and its officers, employees, subsidiaries, affiliates, and distributors harmless against all claims, costs, damages, and expenses, and reasonable attorney fees arising out of, directly or indirectly, any claim of personal injury or death associated with such unintended or unauthorized use, even if such claim alleges that **onsemi** was negligent regarding the design or manufacture of the part. **onsemi** is an Equal Opportunity/Affirmative Action Employer. This literature is subject to all applicable copyright laws and is not for resale in any manner.

PUBLICATION ORDERING INFORMATION

LITERATURE FULFILLMENT:

Email Requests to: orderlit@onsemi.com

onsemi Website: www.onsemi.com

TECHNICAL SUPPORT

North American Technical Support:

Voice Mail: 1 800-282-9855 Toll Free USA/Canada

Phone: 011 421 33 790 2910

Europe, Middle East and Africa Technical Support:

Phone: 00421 33 790 2910

For additional information, please contact your local Sales Representative

