

# ON Semiconductor

## Is Now

The logo for onsemi, featuring the word "onsemi" in a dark teal, lowercase, sans-serif font. The letter "i" is stylized with a white dot and a teal vertical bar. A small orange triangle is positioned above the top right of the "i". A trademark symbol (TM) is located to the right of the logo.

To learn more about onsemi™, please visit our website at  
[www.onsemi.com](http://www.onsemi.com)

---

**onsemi** and **onsemi** and other names, marks, and brands are registered and/or common law trademarks of Semiconductor Components Industries, LLC dba "**onsemi**" or its affiliates and/or subsidiaries in the United States and/or other countries. **onsemi** owns the rights to a number of patents, trademarks, copyrights, trade secrets, and other intellectual property. A listing of **onsemi** product/patent coverage may be accessed at [www.onsemi.com/site/pdf/Patent-Marking.pdf](http://www.onsemi.com/site/pdf/Patent-Marking.pdf). **onsemi** reserves the right to make changes at any time to any products or information herein, without notice. The information herein is provided "as-is" and **onsemi** makes no warranty, representation or guarantee regarding the accuracy of the information, product features, availability, functionality, or suitability of its products for any particular purpose, nor does **onsemi** assume any liability arising out of the application or use of any product or circuit, and specifically disclaims any and all liability, including without limitation special, consequential or incidental damages. Buyer is responsible for its products and applications using **onsemi** products, including compliance with all laws, regulations and safety requirements or standards, regardless of any support or applications information provided by **onsemi**. "Typical" parameters which may be provided in **onsemi** data sheets and/or specifications can and do vary in different applications and actual performance may vary over time. All operating parameters, including "Typicals" must be validated for each customer application by customer's technical experts. **onsemi** does not convey any license under any of its intellectual property rights nor the rights of others. **onsemi** products are not designed, intended, or authorized for use as a critical component in life support systems or any FDA Class 3 medical devices or medical devices with a same or similar classification in a foreign jurisdiction or any devices intended for implantation in the human body. Should Buyer purchase or use **onsemi** products for any such unintended or unauthorized application, Buyer shall indemnify and hold **onsemi** and its officers, employees, subsidiaries, affiliates, and distributors harmless against all claims, costs, damages, and expenses, and reasonable attorney fees arising out of, directly or indirectly, any claim of personal injury or death associated with such unintended or unauthorized use, even if such claim alleges that **onsemi** was negligent regarding the design or manufacture of the part. **onsemi** is an Equal Opportunity/Affirmative Action Employer. This literature is subject to all applicable copyright laws and is not for resale in any manner. Other names and brands may be claimed as the property of others.

# NCP5005

## Compact Backlight LED Boost Driver

The NCP5005 is a high efficiency boost converter operating in current loop, based on a PFM mode, to drive White LED. The current mode regulation allows a uniform brightness of the LEDs. The chip has been optimized for small ceramic capacitors, capable to supply up to 1.0 W output power.

### Features

- 2.7 to 5.5 V Input Voltage Range
- $V_{out}$  to 24 V Output Compliance Allows up to 5 LEDs Drive in Series
- Built-in Overvoltage Protection
- Full EMI Immunity
- Inductor Based Converter brings up to 90% Efficiency
- Constant Output Current Regulation
- 0.3  $\mu$ A Standby Quiescent Current
- Includes Dimming Function (PWM)
- Enable Function Driven Directly from Low Battery Voltage Source
- Automatic LEDs Current Matching
- Thermal Shutdown Protection
- All Pins are Fully ESD Protected
- Low EMI Radiation
- Pb-Free Package is Available

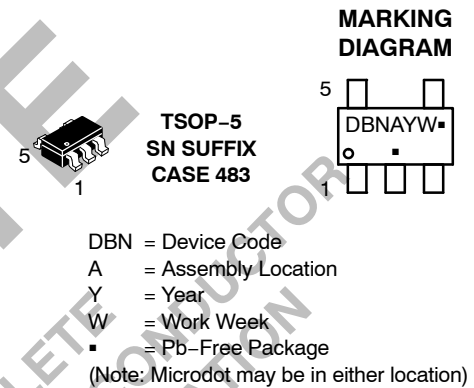
### Typical Applications

- LED Display Back Light Control
- Keyboard Back Light
- High Efficiency Step Up Converter

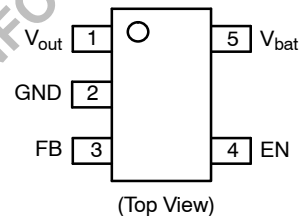


ON Semiconductor®

[www.onsemi.com](http://www.onsemi.com)



### PIN CONNECTIONS



### ORDERING INFORMATION

Device	Package	Shipping†
NCP5005SNT1G	TSOP-5 (Pb-Free)	3000 Tape & Reel

†For information on tape and reel specifications, including part orientation and tape sizes, please refer to our Tape and Reel Packaging Specifications Brochure, BRD8011/D.

# NCP5005

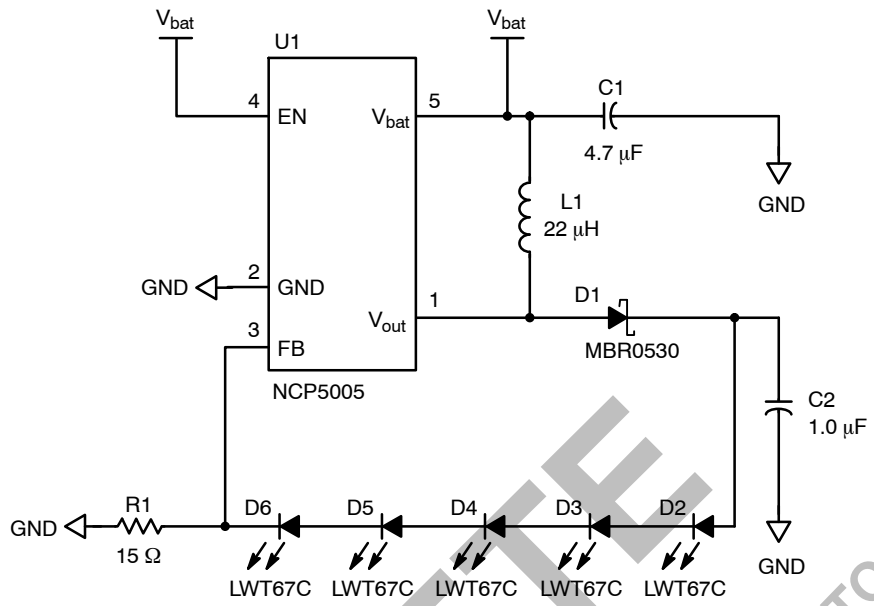


Figure 1. Typical Application

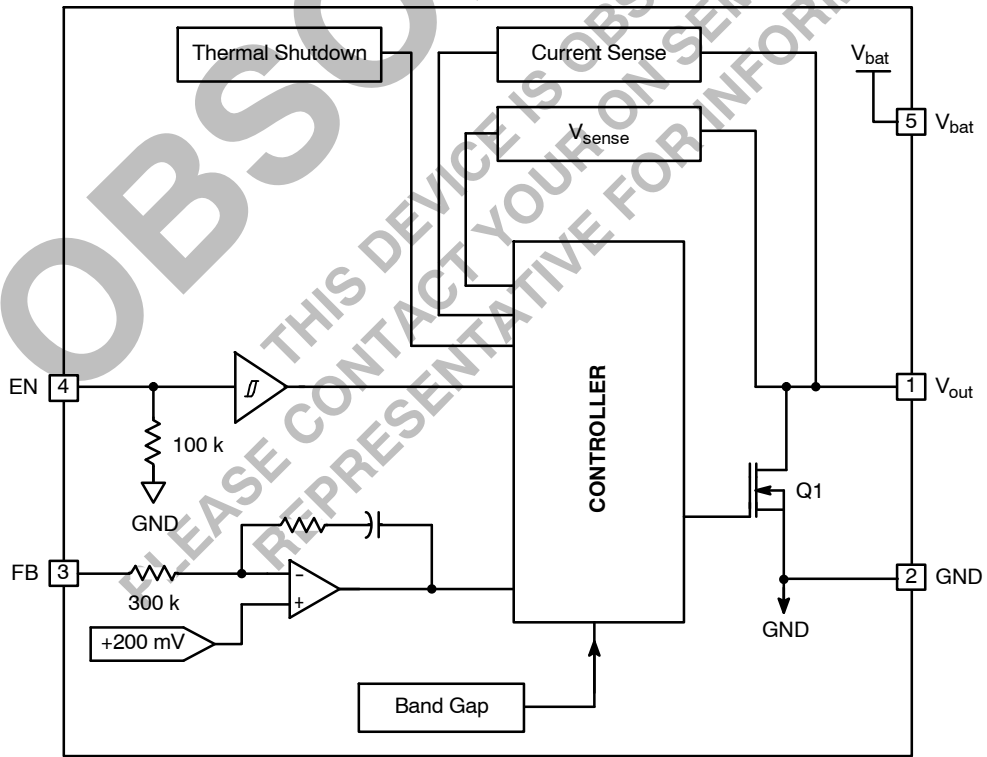


Figure 2. Block Diagram

# NCP5005

## PIN FUNCTION DESCRIPTION

Pin	Pin Name	Type	Description
1	V <sub>out</sub>	POWER	This pin is the power side of the external inductor and must be connected to the external Schottky diode. It provides the output current to the load. Since the boost converter operates in a current loop mode, the output voltage can range up to +24 V but shall not extend this limit. However, if the voltage on this pin is higher than the Over Voltage Protection threshold (OVP) the device comes back to shutdown mode. To restart the chip, one must either send a Low to High sequence on Pin EN, or switch off the V <sub>bat</sub> supply. A capacitor must be used on the output voltage to avoid false triggering of the OVP circuit. This capacitor should be 1.0 μF minimum. Ceramic type, (ESR <100 mΩ), is mandatory to achieve the high end efficiency. This capacitor limits the noise created by the fast transients present in this circuitry. In order to limit the inrush current and to operate with an acceptable start-up time, it is recommended to use any value between 1.0 μF and 8.2 μF capacitor maximum. Care must be observed to avoid EMI through the PCB copper tracks connected to this pin.
2	GND	POWER	This pin is the system ground for the NCP5005 and carries both the power and the analog signals. High quality ground must be provided to avoid spikes and/or uncontrolled operation. Care must be observed to avoid high-density current flow in a limited PCB copper track. Ground plane technique is recommended.
3	FB	ANALOG INPUT	This pin provides the output current range adjustment by means of a sense resistor connected to the analog control or with a PWM control. The dimming function can be achieved by applying a PWM voltage technique to this pin (see Figure 29). The current output tolerance depends upon the accuracy of this resistor. Using a ±5% metal film resistor or better, yields a good enough output current accuracy. Note: A built-in comparator switch OFF the DC/DC converter if the voltage sensed across this pin and ground is higher than 700 mV (typical).
4	EN	DIGITAL INPUT	This is an Active-High logic input which enables the boost converter. The built-in pull down resistor disables the device when the EN pin is left open. The LED brightness can be controlled by applying a pulse width modulated signal to the enable pin (see Figure 31).
5	V <sub>bat</sub>	POWER	The external voltage supply is connected to this pin. A high quality reservoir capacitor must be connected across Pin 1 and Ground to achieve the specified output voltage parameters. A 4.7 μF/6.3 V, low ESR capacitor must be connected as close as possible across Pin 5 and ground Pin 2. The X5R or X7R ceramic MURATA types are recommended. The return side of the external inductor shall be connected to this pin. Typical application will use a 22 μH, size 1008, to handle the 1.0 to 100 mA max output current range. On the other hand, when the desired output current is above 20 mA, the inductor shall have an ESR < 1.5 Ω to achieve a good efficiency over the V <sub>bat</sub> range.

# NCP5005

## MAXIMUM RATINGS

Rating	Symbol	Value	Unit
Power Supply	$V_{bat}$	6.0	V
Output Power Supply Voltage Compliance	$V_{out}$	28	V
Digital Input Voltage Digital Input Current	EN	$-0.3 < V_{in} < V_{bat} + 0.3$ 1.0	V mA
ESD Capability (Note 1) Human Body Model (HBM) Machine Model (MM)	$V_{ESD}$	2.0 200	kV V
TSOP-5 Package Power Dissipation @ $T_A = +85^\circ\text{C}$ (Note 2) Thermal Resistance, Junction-to-Air	$P_D$ $R_{\theta JA}$	160 250	mW $^\circ\text{C/W}$
Operating Ambient Temperature Range	$T_A$	-25 to +85	$^\circ\text{C}$
Operating Junction Temperature Range	$T_J$	-25 to +125	$^\circ\text{C}$
Maximum Junction Temperature	$T_{Jmax}$	+150	$^\circ\text{C}$
Storage Temperature Range	$T_{stg}$	-65 to +150	$^\circ\text{C}$

Stresses exceeding those listed in the Maximum Ratings table may damage the device. If any of these limits are exceeded, device functionality should not be assumed, damage may occur and reliability may be affected.

- This device series contains ESD protection and exceeds the following tests:  
Human Body Model (HBM)  $\pm 2.0$  kV per JEDEC standard: JESD22-A114  
Machine Model (MM)  $\pm 200$  V per JEDEC standard: JESD22-A115
- The maximum package power dissipation limit must not be exceeded.
- Latch-up current maximum rating:  $\pm 100$  mA per JEDEC standard: JESD78.
- Moisture Sensivity Level (MSL): 1 per IPC/JEDEC standard: J-STD-020A.

**POWER SUPPLY SECTION** (Typical values are referenced to  $T_A = +25^\circ\text{C}$ , Min & Max values are referenced  $-25^\circ\text{C}$  to  $+85^\circ\text{C}$  ambient temperature, unless otherwise noted.)

Rating	Pin	Symbol	Min	Typ	Max	Unit
Power Supply	4	$V_{bat}$	2.7	-	5.5	V
Output Load Voltage Compliance	5	$V_{out}$	21	24	-	V
Continuous DC Current in the Load @ $V_{out} = 3 \times \text{LED}$ , $L = 22 \mu\text{H}$ , ESR < $1.5 \Omega$ , $V_{bat} = 3.6$ V	5	$I_{out}$	50	-	-	mA
Stand By Current, @ $I_{out} = 0$ mA, EN = L, $V_{bat} = 3.6$ V	4	$I_{stdb}$	-	0.3	-	$\mu\text{A}$
Stand By Current, @ $I_{out} = 0$ mA, EN = L, $V_{bat} = 5.5$ V	4	$I_{stdb}$	-	0.8	3.0	$\mu\text{A}$
Inductor Discharging Time @ $V_{bat} = 3.6$ V, $L = 22 \mu\text{H}$ , $3 \times \text{LED}$ , $I_{out} = 10$ mA	4	$T_{offmax}$	-	320	-	ns
Thermal Shutdown Protection	-	$T_{SD}$	-	160	-	$^\circ\text{C}$
Thermal Shutdown Protection Hysteresis	-	$T_{SDH}$	-	30	-	$^\circ\text{C}$

# NCP5005

**ANALOG SECTION** (Typical values are referenced to  $T_A = +25^\circ\text{C}$ , Min & Max values are referenced  $-25^\circ\text{C}$  to  $+85^\circ\text{C}$  ambient temperature, unless otherwise noted.)

Rating	Pin	Symbol	Min	Typ	Max	Unit
High Level Input Voltage	4	EN	1.3	-	-	V
Low Level Input Voltage			-	-	0.4	V
EN Pull Down Resistor	4	$R_{EN}$	-	100	-	$k\Omega$
Feedback Voltage Threshold	3	FB	185	200	225	mV
Output Current Stabilization Time Delay following a DC/DC Start-up, @ $V_{bat} = 3.60\text{ V}$ , $L = 22\ \mu\text{H}$ , $I_{out} = 20\text{ mA}$	1	$I_{outdy}$	-	100	-	$\mu\text{s}$
Internal Switch ON Resistor @ $T_{amb} = +25^\circ\text{C}$	1	$QR_{DSON}$	-	1.7	-	$\Omega$

5. The overall tolerance depends upon the accuracy of the external resistor.

## ESD PROTECTION

The NCP5005 includes silicon devices to protect the pins against the ESD spikes voltages. To cope with the different ESD voltages developed in the applications, the built-in structures have been designed to handle  $\pm 2.0\text{ kV}_{in}$  Human Body Model (HBM) and  $\pm 200\text{ V}$  in Machine Model (MM) on each pin.

## DC/DC OPERATION

The DC/DC converter is designed to supply a constant current to the external load, the circuit being powered from a standard battery supply. Since the regulation is made by

means of a current loop, the output voltage will varies depending upon the dynamic impedance presented by the load.

Considering high intensity LED, the output voltage can range from a low 6.40 V (two LED in series biased with a low current), up to 21 V, the voltage compliance the chip can sustain continuously.

The basic DC/DC structure is depicted in Figure 3. With a 28 V maximum rating voltage capability, the power device can accommodate high voltage source without any leakage current downgrading.

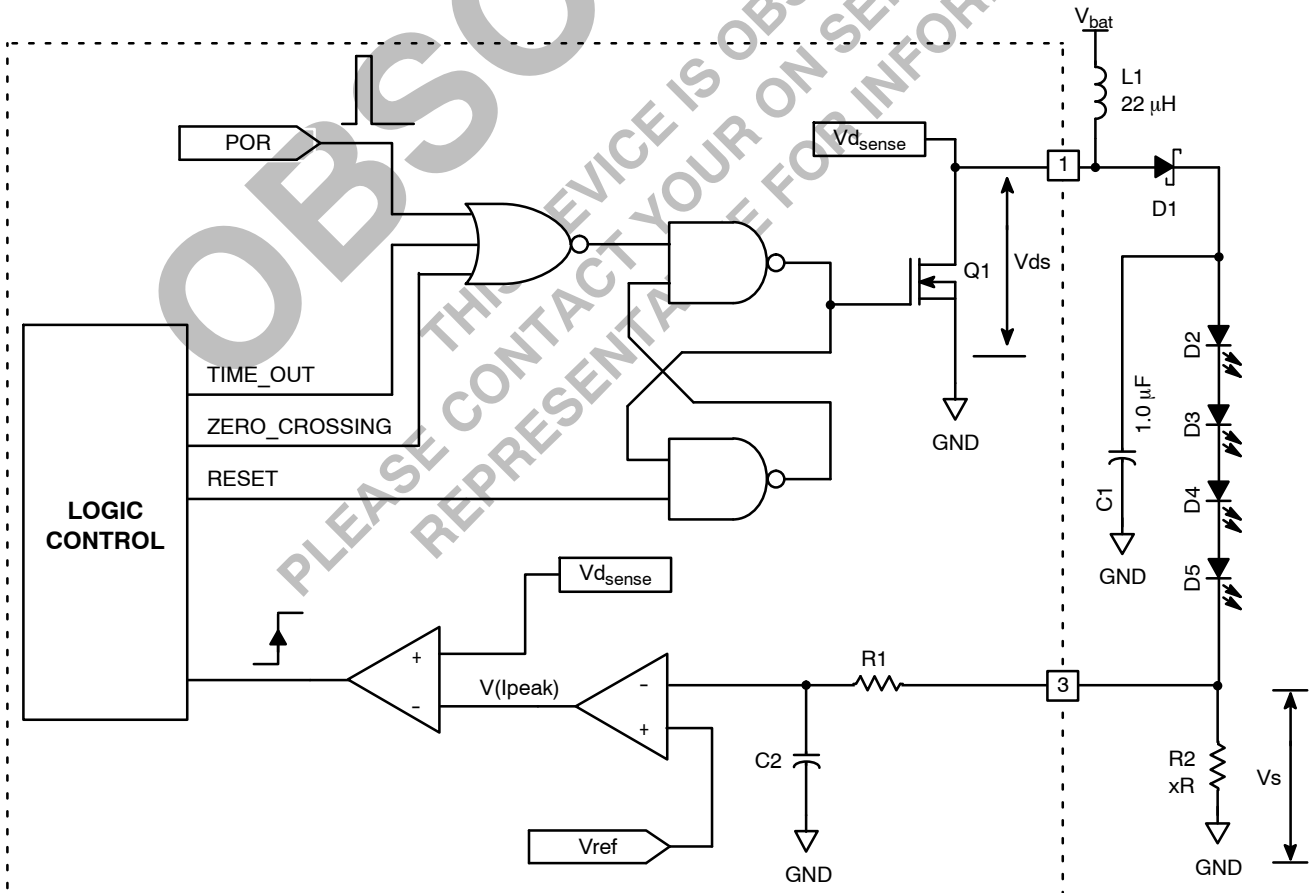


Figure 3. Basic DC/DC Converter Structure

Basically, the chip operates with two cycles:

Cycle #1: time  $t_1$ , the energy is stored into the inductor

Cycle #2: time  $t_2$ , the energy is dumped to the load

The POR signal sets the flip-flop and the first cycle takes place. When the current hits the peak value, defined by the

error amplifier associated to the loop regulation, the flip-flop resets, the NMOS is deactivated and the current is dumped into the load. Since the timings depend on the environment, the internal timer limits the toff cycle to 320 ns (typical), making sure the system operates in a continuous mode to maximize the energy transfer.

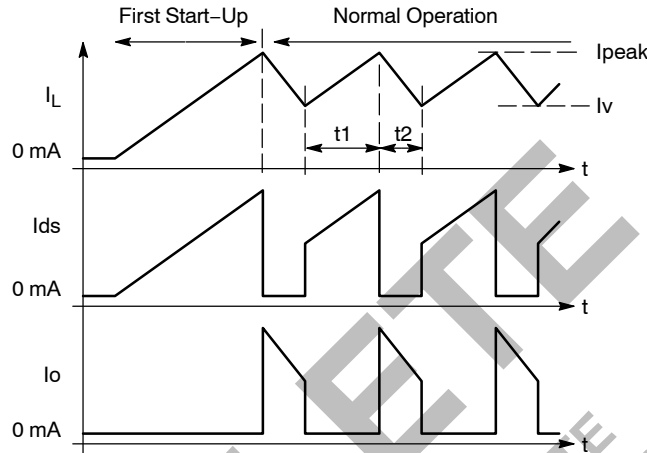


Figure 4. Basic DC-DC Operation

Based on the data sheet, the current flowing into the inductor is bounded by two limits:

- I<sub>peak</sub> Value: Internally fixed to 350 mA typical
- I<sub>v</sub> Value: Limited by the fixed Toff time built in the chip (320 ns typical)

The system operates in a continuous mode as depicted in Figure 4 and  $t_1$  and  $t_2$  times can be derived from basic equations. (Note: The equations are for theoretical analysis only, they do not include the losses.)

$$L = E \cdot \frac{dl}{dt} \quad (\text{eq. 1})$$

Let  $V_{bat} = E$ , then:

$$t_1 = \frac{(I_p - I_v) \cdot L}{V_{bat}} \quad (\text{eq. 2})$$

$$t_2 = \frac{(I_p - I_v) \cdot L}{V_o - V_{bat}} \quad (\text{eq. 3})$$

Since  $t_2 = 320$  ns typical and  $V_o = 21$  V maximum, then (assuming a typical  $V_{bat} = 3.0$  V):

$$\Delta I = \frac{t_2 \cdot (V_o - V_{bat})}{L} \quad (\text{eq. 4})$$

$$\Delta I_{max} = \frac{320 \text{ ns} \cdot (21 - 3.0)}{22 \mu\text{H}} = 261 \text{ mA}$$

Of course, from a practical stand point, the inductor must be sized to cope with the peak current present in the circuit

to avoid saturation of the core. On top of that, the ferrite material shall be capable to operate at high frequency (1.0 MHz) to minimize the Foucault's losses developed during the cycles.

The operating frequency can be derived from the electrical parameters. Let  $V = V_o - V_{bat}$ , rearranging Equation 1:

$$t_{on} = \frac{dl \cdot L}{E} \quad (\text{eq. 5})$$

Since toff is nearly constant (according to the 320 ns typical time), the  $dl$  is constant for a given load and inductance value. Rearranging Equation 5 yields:

$$t_{on} = \frac{V \cdot dt \cdot L}{E} \quad (\text{eq. 6})$$

Let  $E = V_{bat}$ , and  $V_{opk} =$  output peak voltage, then:

$$t_{on} = \frac{(V_{opk} - V_{bat}) \cdot dt}{V_{bat}} \quad (\text{eq. 7})$$

Finally, the operating frequency is:

$$f = \frac{1}{t_{on} + t_{off}} \quad (\text{eq. 8})$$

The output power supplied by the NCP5005 is limited to one watt: Figure 5 shows the maximum power that can be delivered by the chip as a function of the output voltage.

# NCP5005

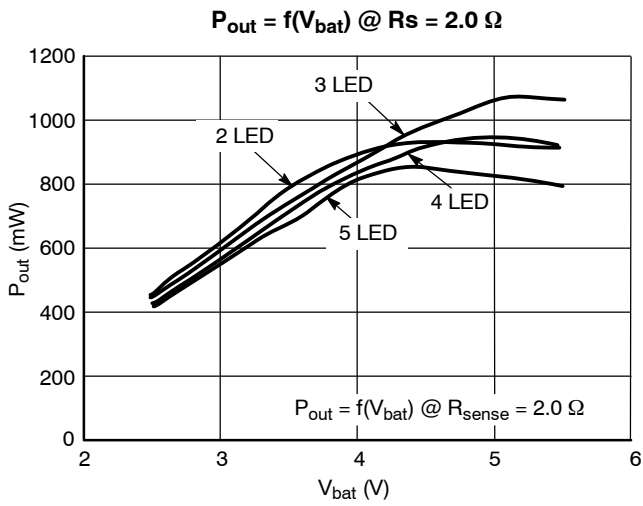
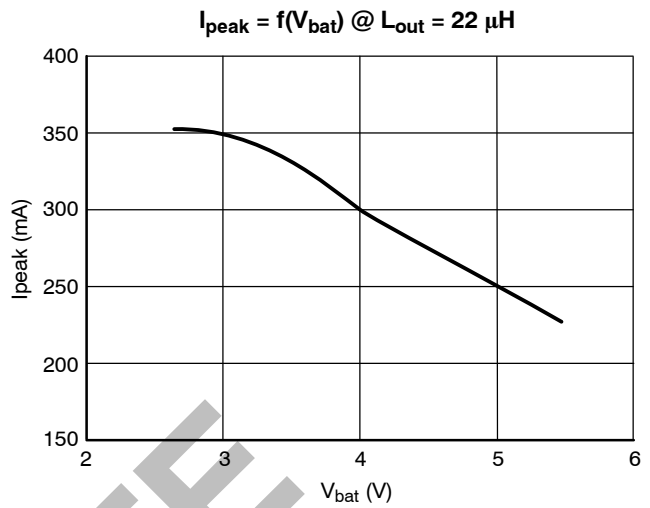
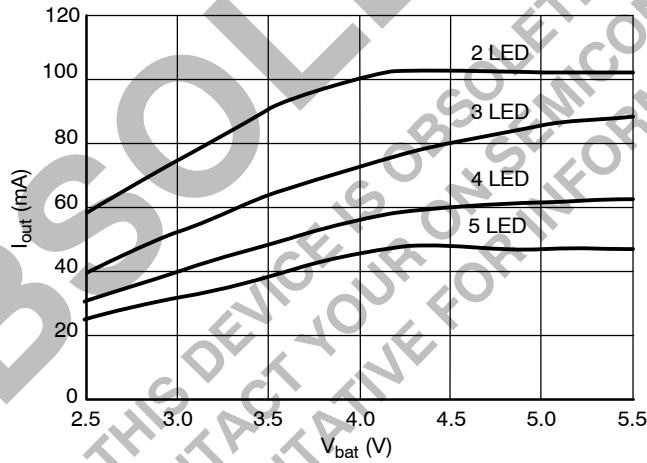


Figure 5. Maximum Output Power as a Function of the Battery Supply Voltage



Test conditions:  $L = 22 \mu H$ ,  $R_{sense} = 10 \Omega$ ,  $T_{amb} = +20^\circ C$

Figure 6. Typical Inductor Peak Current as a Function of  $V_{bat}$  Voltage



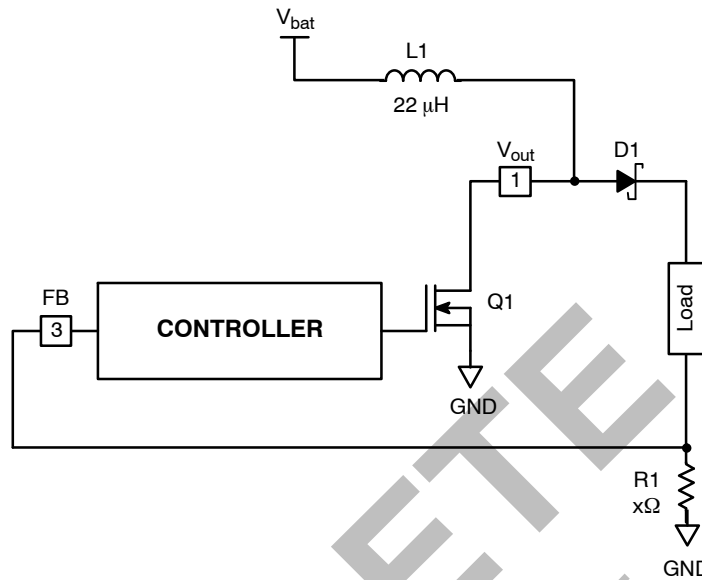
Test conditions:  $L = 22 \mu H$ ,  $R_{sense} = 2.0 \Omega$ ,  $T_{amb} = +25^\circ C$

Figure 7. Maximum Output Current as a Function of  $V_{bat}$



**Output Current Range Set-Up**

The current regulation is achieved by means of an external sense resistor connected in series with the LED string.

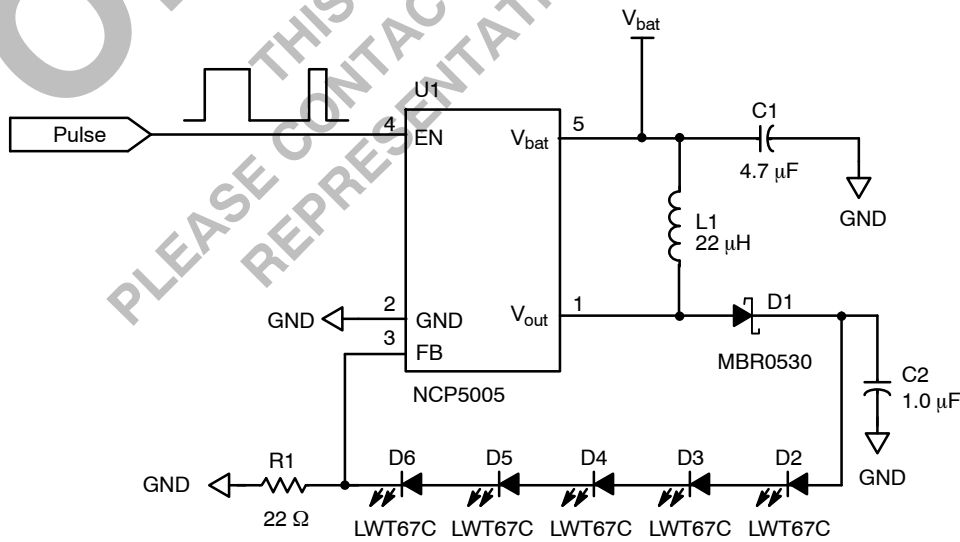


**Figure 8. Output Current Feedback**

The current flowing through the LED creates a voltage drop across the sense resistor R1. The voltage drop is constantly monitored internally, and maximum peak current allowed in the inductor is set accordingly in order to keep constant this voltage drop (and thus the current flowing through the LED). For example, should one need a 10 mA output current, the sense resistor should be sized according to the following equation:

$$R_1 = \frac{\text{Feedback Threshold}}{I_{out}} = \frac{200 \text{ mV}}{10 \text{ mA}} = 20 \Omega \quad (\text{eq. 9})$$

A standard 5% tolerance resistor, 22 Ω SMD device, yields 9.09 mA, good enough to fulfill the back light demand. The typical application schematic diagram is provided in Figure 9.



**Figure 9. Basic Schematic Diagram**

**Output Load Drive**

In order to optimize the built-in Boost capabilities, one shall operate the NCP5005 in the continuous output current mode. Such a mode is achieved by using an external reservoir capacitor (see Table 1) across the LED.

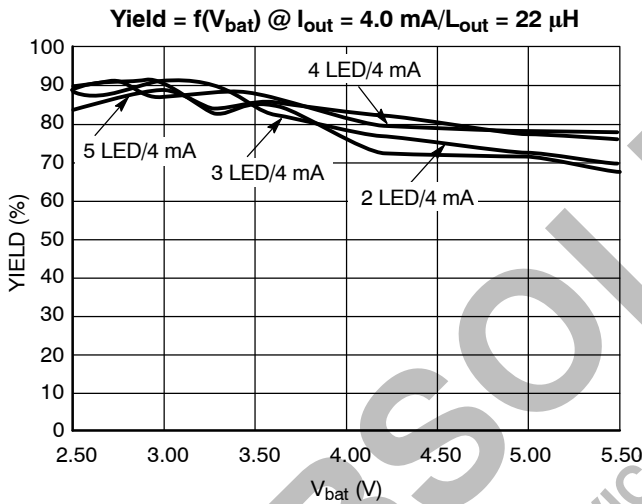
At this point, the peak current flowing into the LED diodes shall be within the maximum ratings specified for these devices. Of course, pulsed operation can be achieved, due to the EN signal Pin 4, to force high current into the LED when necessary.

The Schottky diode D1, associated with capacitor C2 (see Figure 9), provides a rectification and filtering function.

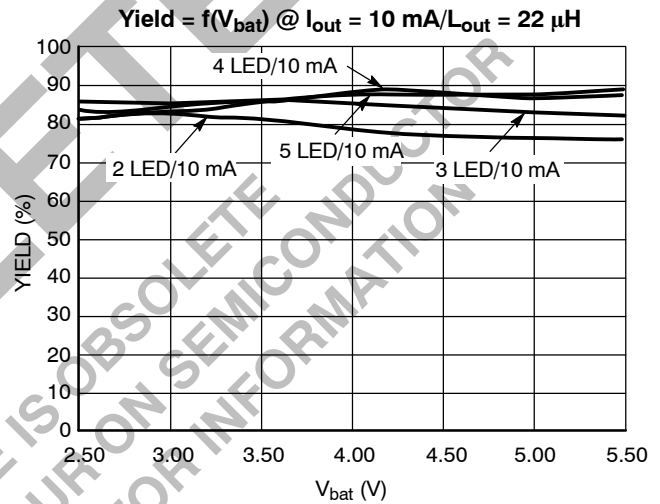
When a pulse-operating mode is acceptable:

- A PWM mode control can be used to adjust the output current range by means of a resistor and a capacitor connected across FB pin. On the other hand, the Schottky diode can be removed and replaced by at least one LED diode, keeping in mind such LED shall sustain the large pulsed peak current during the operation.

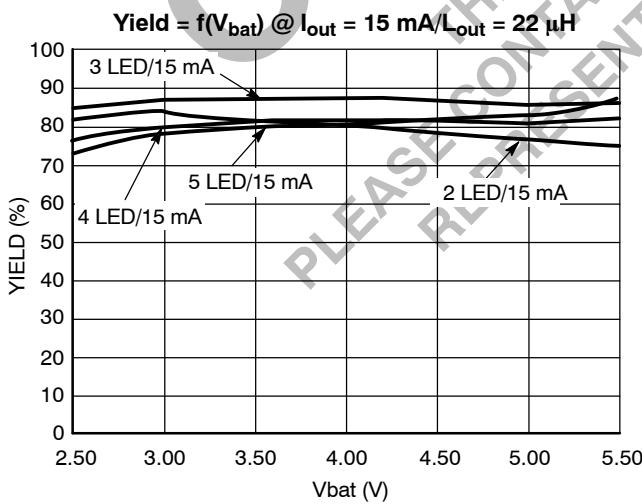
**TYPICAL OPERATING CHARACTERISTICS**



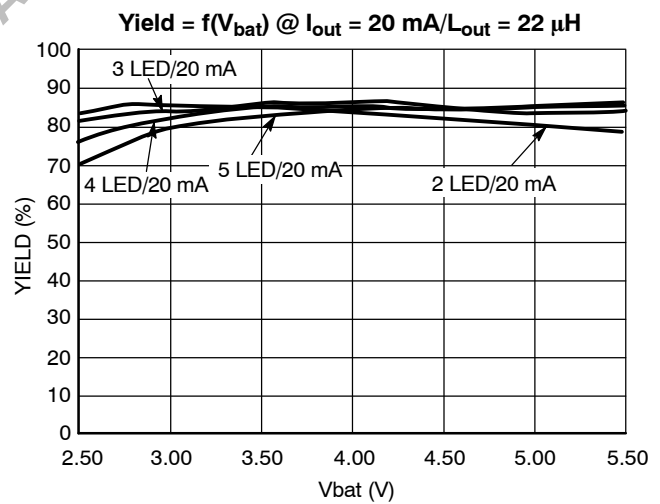
**Figure 10. Overall Efficiency vs. Power Supply @  $I_{out} = 4.0 \text{ mA}$ ,  $L = 22 \mu\text{H}$**



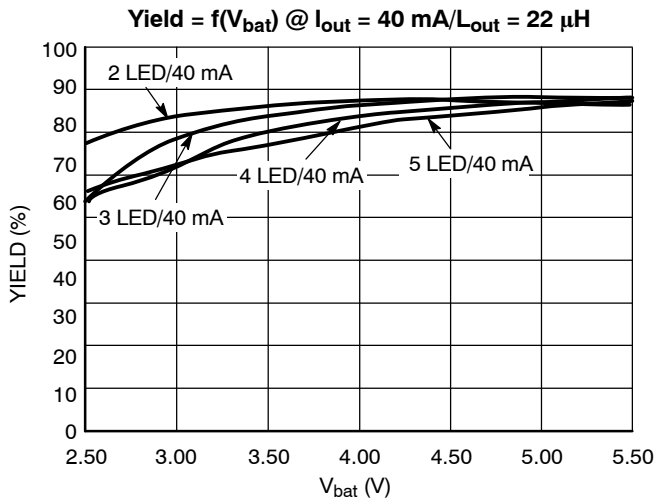
**Figure 11. Overall Efficiency vs. Power Supply @  $I_{out} = 10 \text{ mA}$ ,  $L = 22 \mu\text{H}$**



**Figure 12. Overall Efficiency vs. Power Supply @  $I_{out} = 15 \text{ mA}$ ,  $L = 22 \mu\text{H}$**

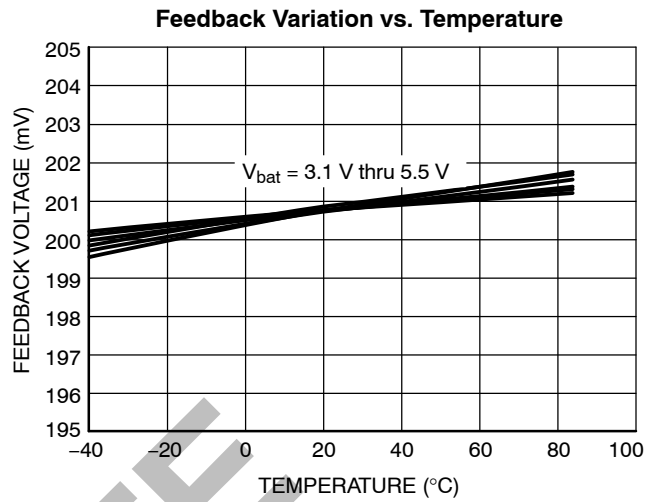


**Figure 13. Overall Efficiency vs. Power Supply @  $I_{out} = 20 \text{ mA}$ ,  $L = 22 \mu\text{H}$**

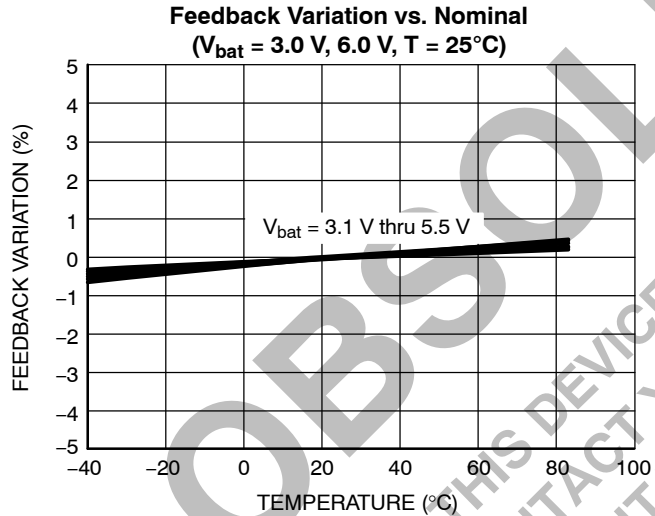


All curve conditions:  $L = 22\text{ }\mu\text{H}$ ,  $C_{in} = 4.7\text{ }\mu\text{F}$ ,  $C_{out} = 1.0\text{ }\mu\text{F}$ ,  
Typical curve @  $T^\circ = +25^\circ\text{C}$

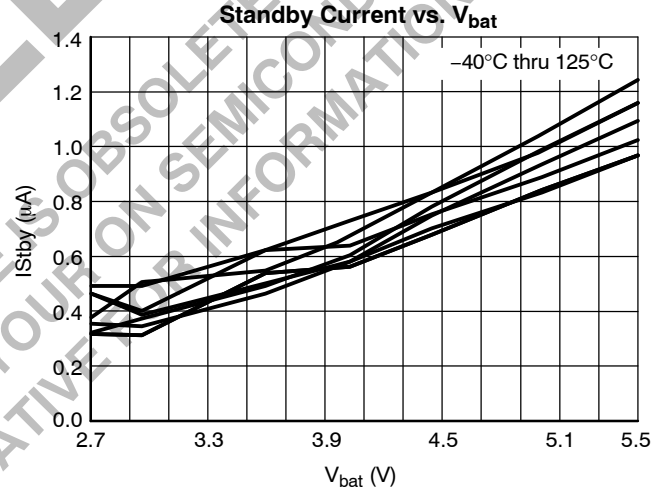
**Figure 14. Overall Efficiency vs. Power Supply @  $I_{out} = 40\text{ mA}$ ,  $L = 22\text{ }\mu\text{H}$**



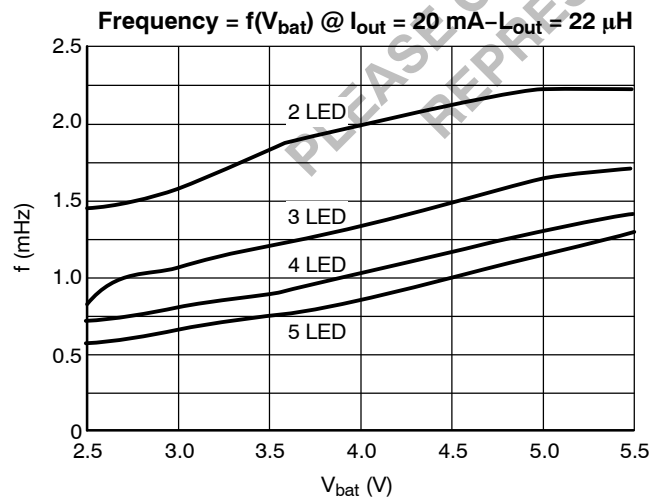
**Figure 15. Feedback Voltage Stability**



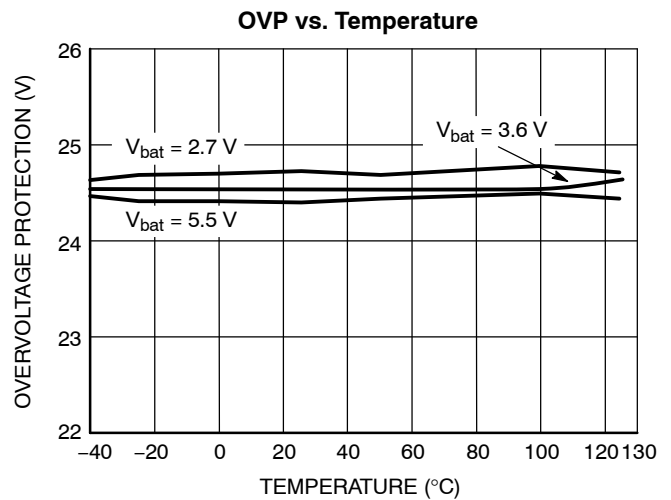
**Figure 16. Feedback Voltage Variation**



**Figure 17. Standby Current**



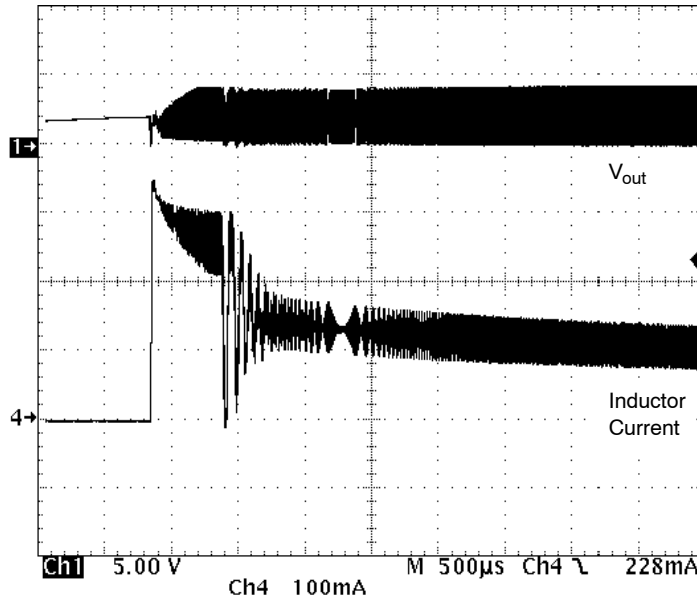
**Figure 18. Typical Operating Frequency**



**Figure 19. Overvoltage Protection**

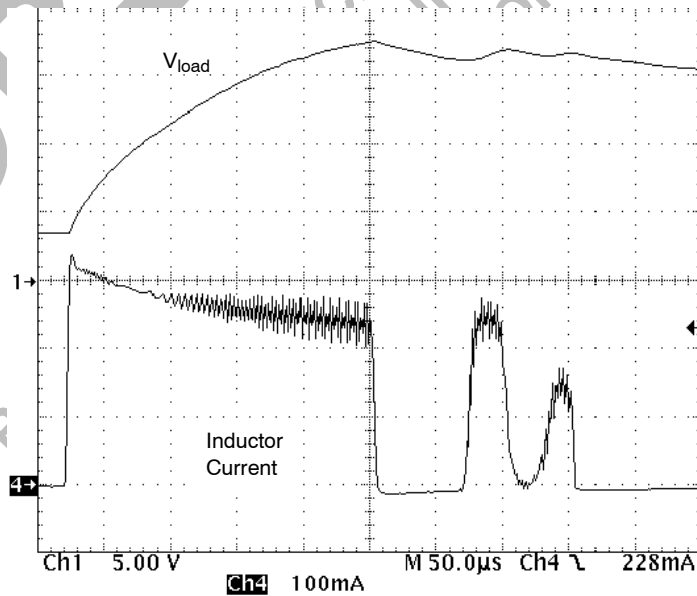
# NCP5005

## TYPICAL OPERATING WAVEFORMS



Conditions:  $V_{bat} = 3.6\text{ V}$ ,  $L_{out} = 22\ \mu\text{H}$ , 5 LED,  $I_{out} = 15\text{ mA}$

Figure 20. Typical Power Up Response

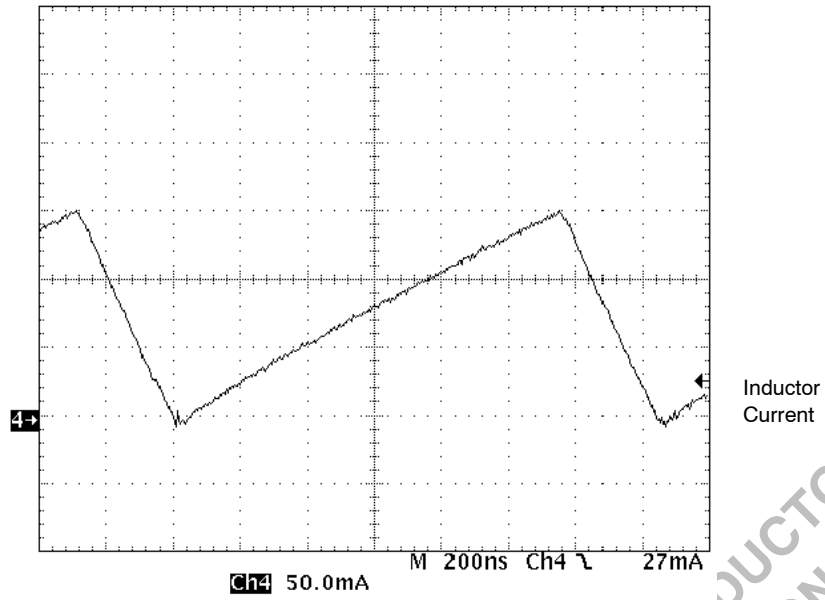


Conditions:  $V_{bat} = 3.6\text{ V}$ ,  $L_{out} = 22\ \mu\text{H}$ , 5 LED,  $I_{out} = 15\text{ mA}$

Figure 21. Typical Start-Up Inductor Current and Output Voltage

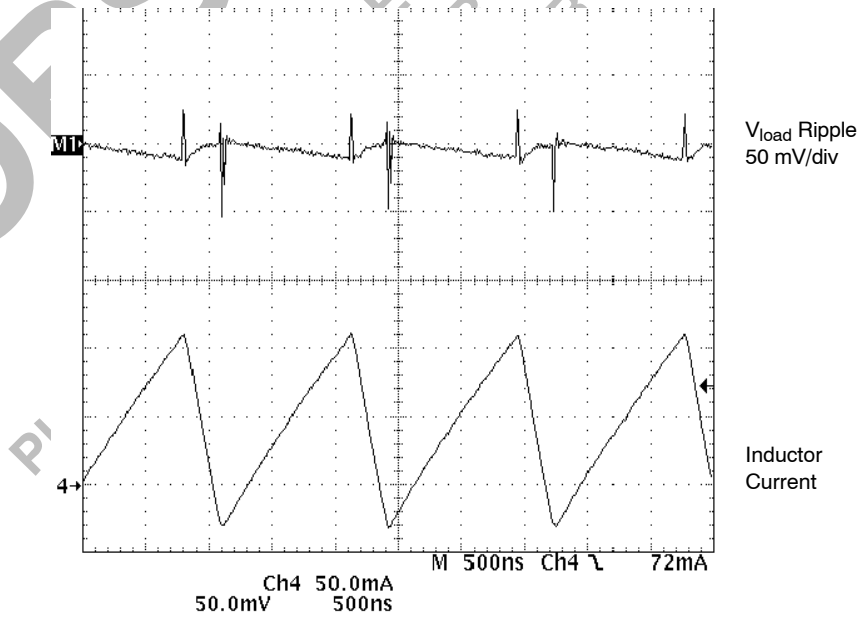
# NCP5005

## TYPICAL OPERATING WAVEFORMS



Conditions:  $V_{bat} = 3.6\text{ V}$ ,  $L_{out} = 22\ \mu\text{H}$ , 5 LED,  $I_{out} = 15\text{ mA}$

Figure 22. Typical Inductor Current

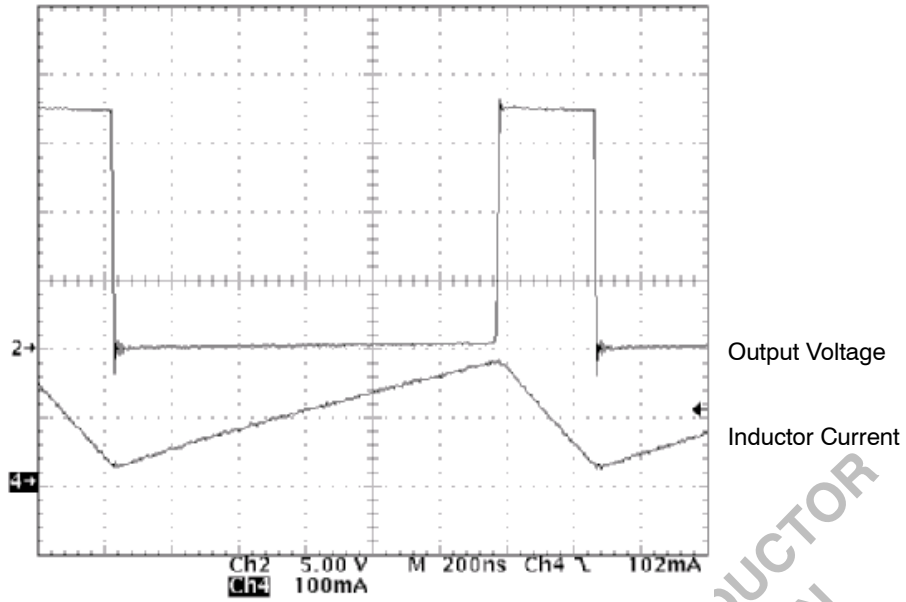


Conditions:  $V_{bat} = 3.6\text{ V}$ ,  $L_{out} = 22\ \mu\text{H}$ , 5 LED,  $I_{out} = 15\text{ mA}$

Figure 23. Typical Output Load Voltage Ripple

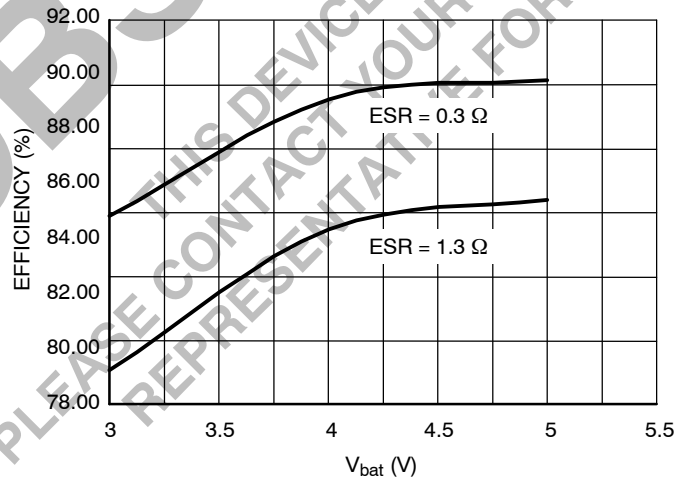
# NCP5005

## TYPICAL OPERATING WAVEFORMS



Test Conditions:  $L = 22 \mu\text{H}$ ,  $I_{\text{out}} = 15 \text{ mA}$ ,  $V_{\text{bat}} = 3.6 \text{ V}$ , Ambient Temperature

Figure 24. Typical Output Peak Voltage



NCP5005: Efficiency =  $f(\text{ESR})$  @ 5 LED,  $I_{\text{Led}} = 20 \text{ mA}$

Figure 25. Efficiency as a Function of  $V_{\text{bat}}$  and Inductor ESR

# NCP5005

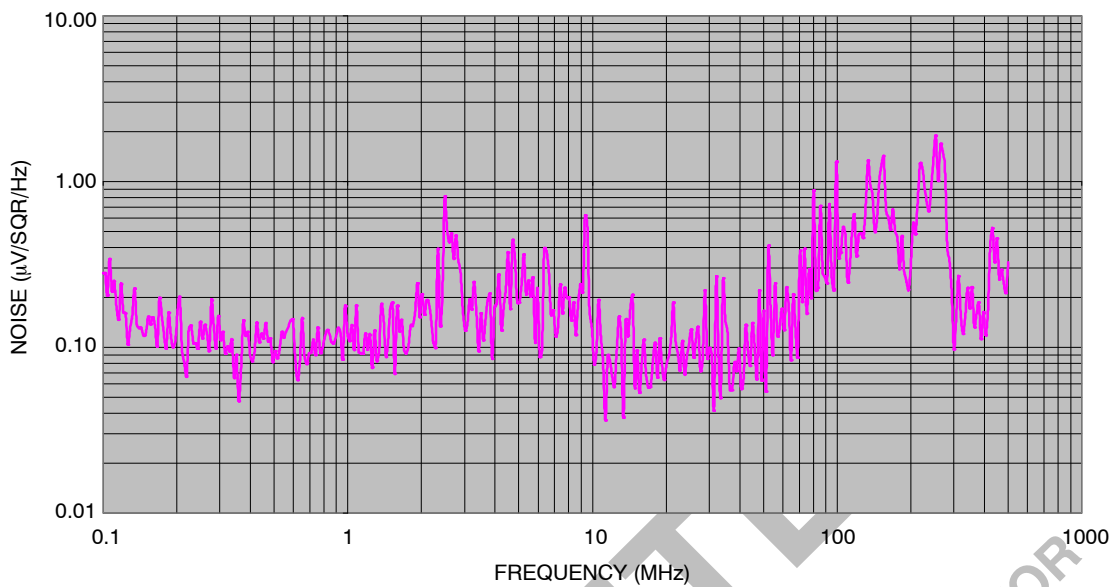
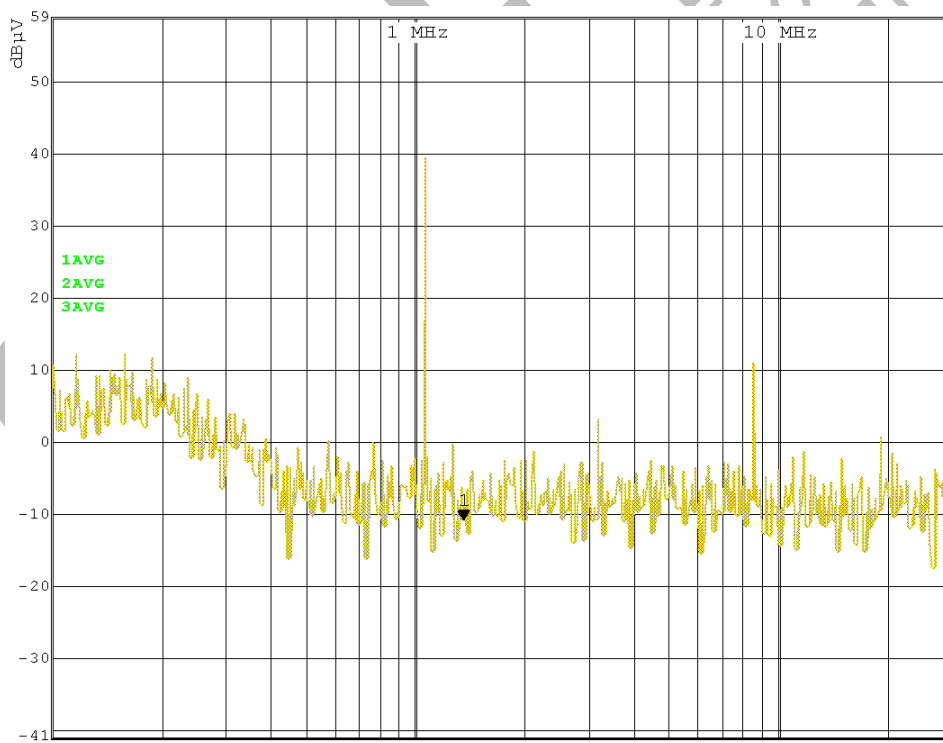


Figure 26. Noise Returned to the Battery



Test Conditions:  $V_{bat} = 3.6\text{ V}$ ,  $I_{out} = 20\text{ mA}$ , string of 3 LED (OSRAM LWT67C)

Figure 27. Relative EMI Over 100 kHz – 30 MHz Bandwidth

TYPICAL APPLICATIONS CIRCUITS

Standard Feedback

The standard feedback provides a constant current to the LED, independently of the  $V_{bat}$  supply and number of LED

associated in series. Figure 28 depicts a typical application to supply 13 mA to the load.

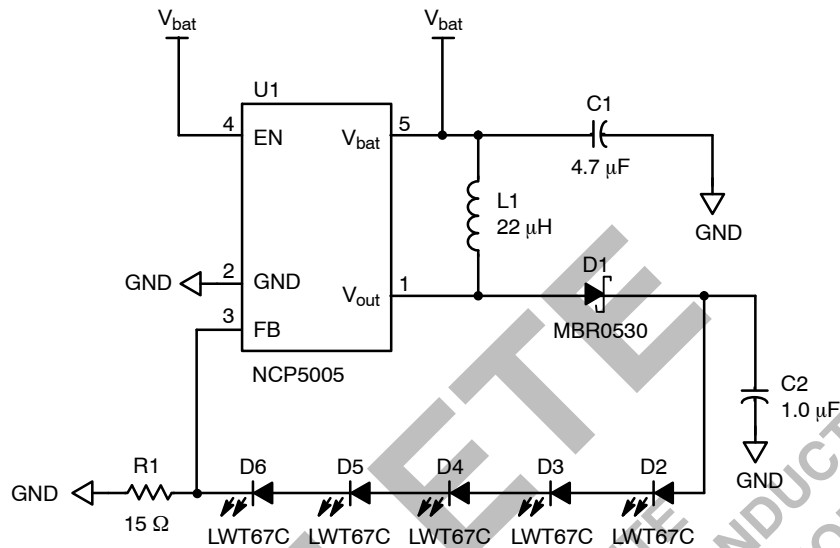


Figure 28. Basic DC Current Mode Operation with Analog Feedback

PWM Operation

The analog feedback Pin 3 provides a way to dim the LED by means of an external PWM signal as depicted in Figure 29. By optimizing the internal high impedance presented by the FB pin, one can set up a simple R/C network to accommodate such a dimming function. Two modes of operation can be considered:

- Pulsed mode, with no filtering
- Averaged mode with filtering capacitor

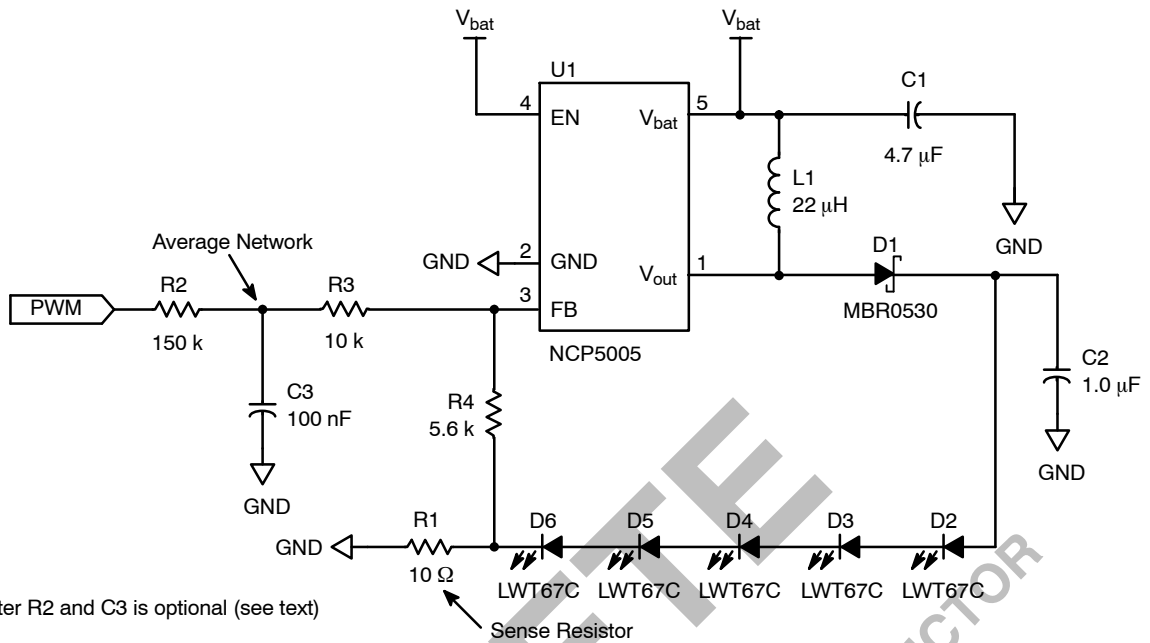
Although the pulsed mode will provide a good dimming function, from a human eye standpoint, it will continuously

start and stop the converter, yielding high transients . These transients might generate spikes difficult to filter out in the rest of the application, a situation not recommended. The output current depends upon the duty cycle of the signal presented to the node Pin 3: this is very similar to the digital control discussed in Figure 31.

The averaged mode yields a noise free operation since the converter operates continuously, together with a very good dimming function. The cost is an extra resistor and one extra capacitor, both being low cost parts.



# NCP5005

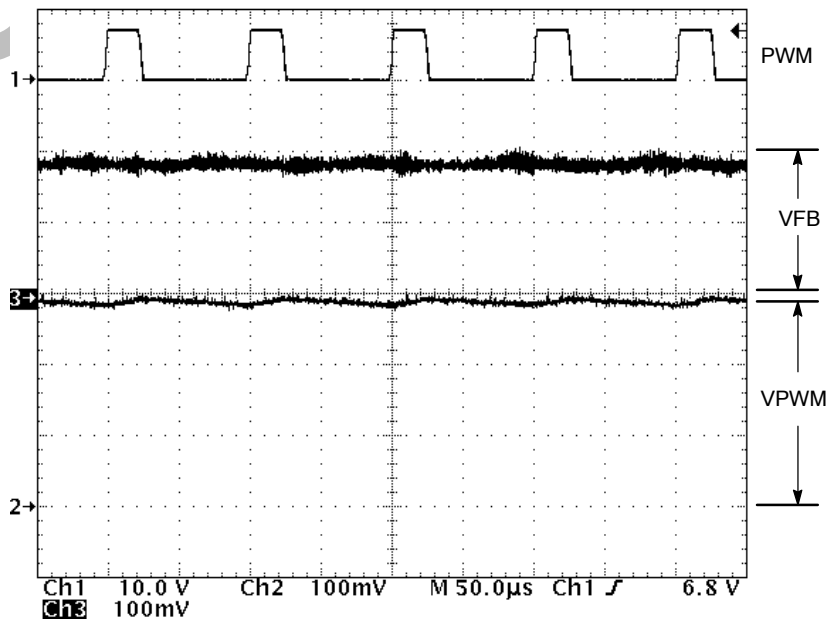


**Figure 29. Basic DC Current Mode Operation with PWM Control**

To implement such a function, let consider the feedback input as an operational amplifier with a high impedance input (reference schematic Figure 29). The analog loop will keep going to balance the current flowing through the sense resistor R1 until the feedback voltage is 200 mV. An extra resistor (R4) isolates the FB node from low resistance to ground, making possible to add an external voltage to this pin.

The time constant  $R2/C3$  generates the voltage across C3, added to the node Pin 1, while  $R2/R3/R4/R1/C3$  create the discharge time constant. In order to minimize the pick up noise at FB node, the resistors shall have relative medium

value, preferably well below 1.0 MΩ. Consequently, let  $R2 = 150\text{ k}$ ,  $R3 = 10\text{ k}$  and  $R4 = 5.6\text{ k}$ . On the other hand, the feedback delay to control the luminosity of the LED shall be acceptable by the user, 10 ms or less being a good compromise. The time constant can now be calculated based on a 400 mV offset voltage at the  $C3/R2/R3$  node to force zero current to the LED. Assuming the PWM signal comes from a standard gate powered by a 3.0 V supply, running at 10 kHz, then a full dimming of the LED can be achieved with a 95% span of the Duty Cycle signal. Figure 30 depicts the behavior under such PWM analog mode.



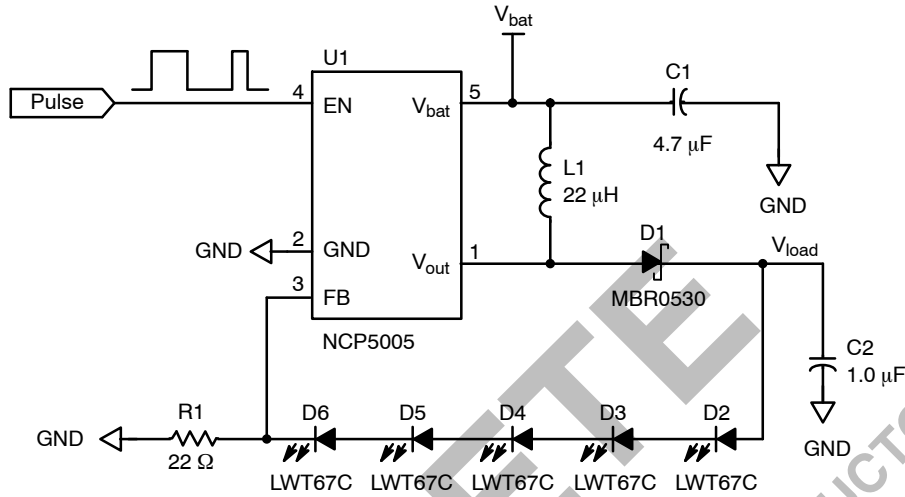
**Figure 30. Operation with Analog PWM,  $f = 10\text{ kHz}$ , DC = 25%**

# NCP5005

## Digital Control

Due to the EN pin, a digitally controlled luminosity can be implemented by providing a PWM signal to this pin (see Figure 31). The output current depends upon the Duty

Cycle, but care must be observed as the DC/DC converter is continuously pulsed ON/OFF and noise are likely to be generated.

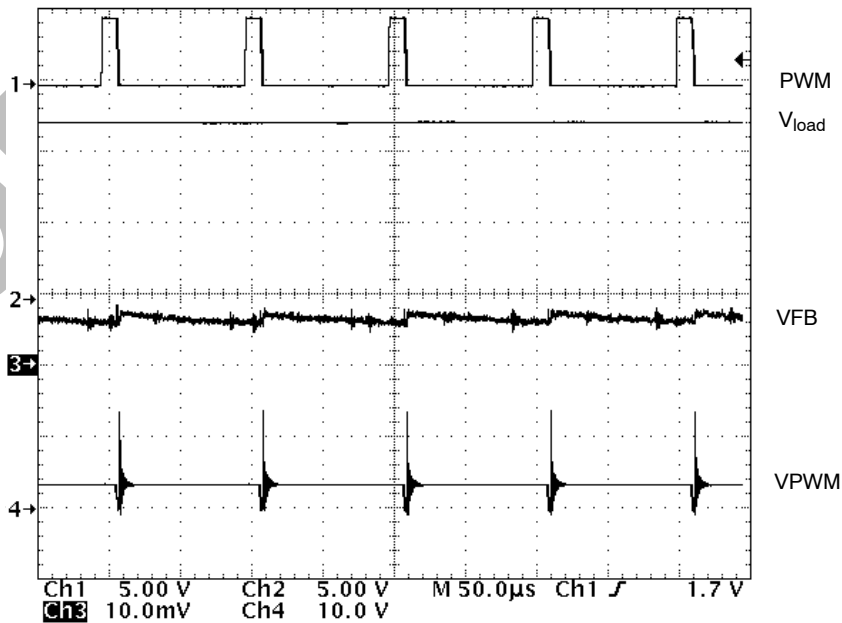


NOTE: Pulse width and frequency depends upon the application constraints.

**Figure 31. Typical Semi-Pulsed Mode of Operation**

The PWM operation, using the EN pin as a digital control, is depicted in Figures 32 and 33. The tests have

been carried out at room temperature with  $V_{bat} = 3.60\text{ V}$ ,  $L = 22\ \mu\text{H}$ , five LEDs in series,  $R_{FB} = 22\ \Omega$ .



**Figure 32. Operation @ PWM = 10 kHz, DC = 10%**

# NCP5005

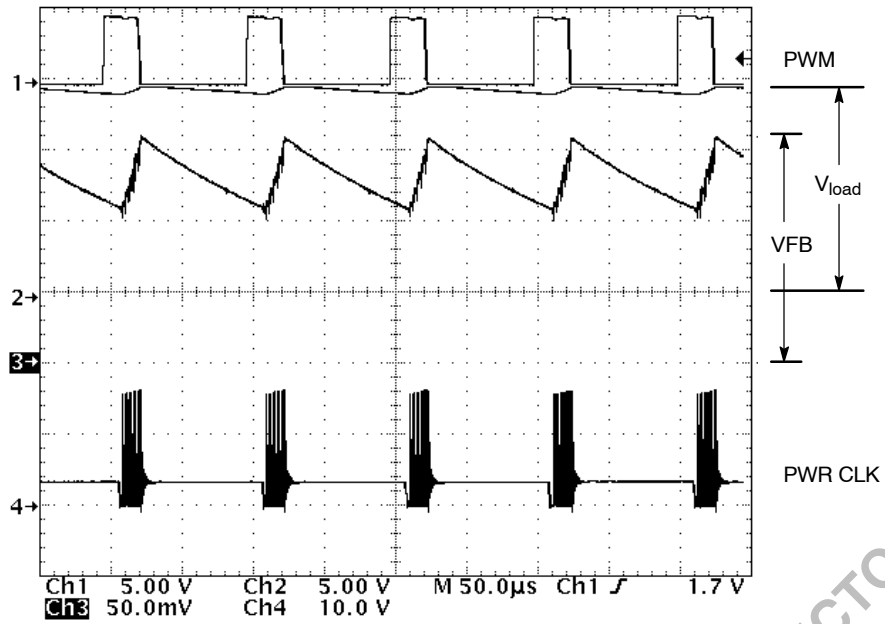


Figure 33. Operation @ PWM = 10 kHz, DC = 25%

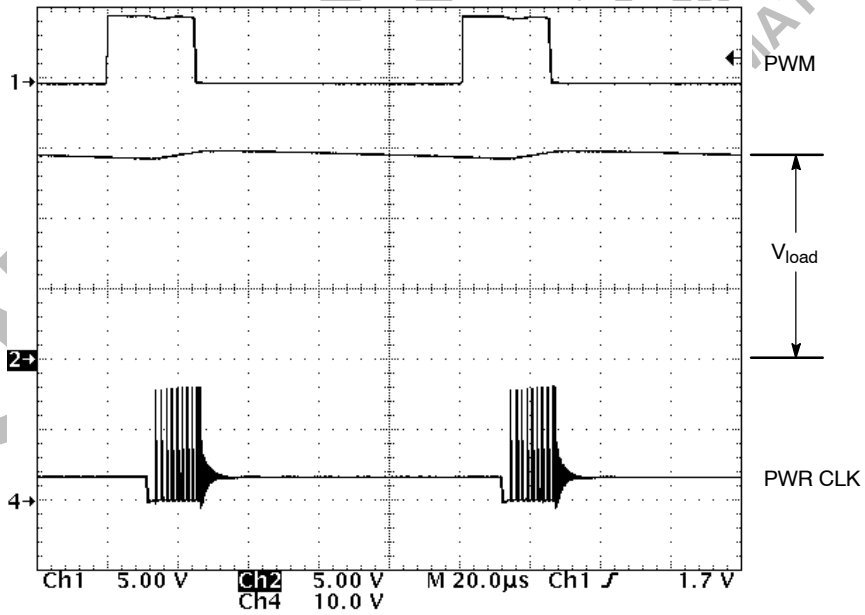


Figure 34. Magnified View of Operation @ PWM = 10 kHz, DC = 25%

## NCP5005

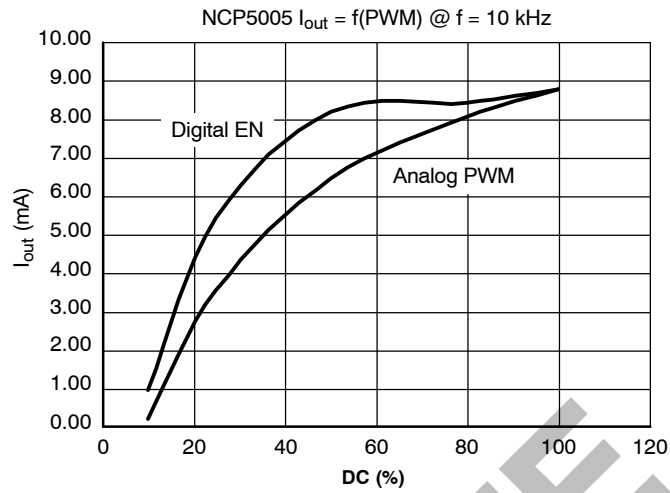


Figure 35. Output Current as a Function of the Operating Condition

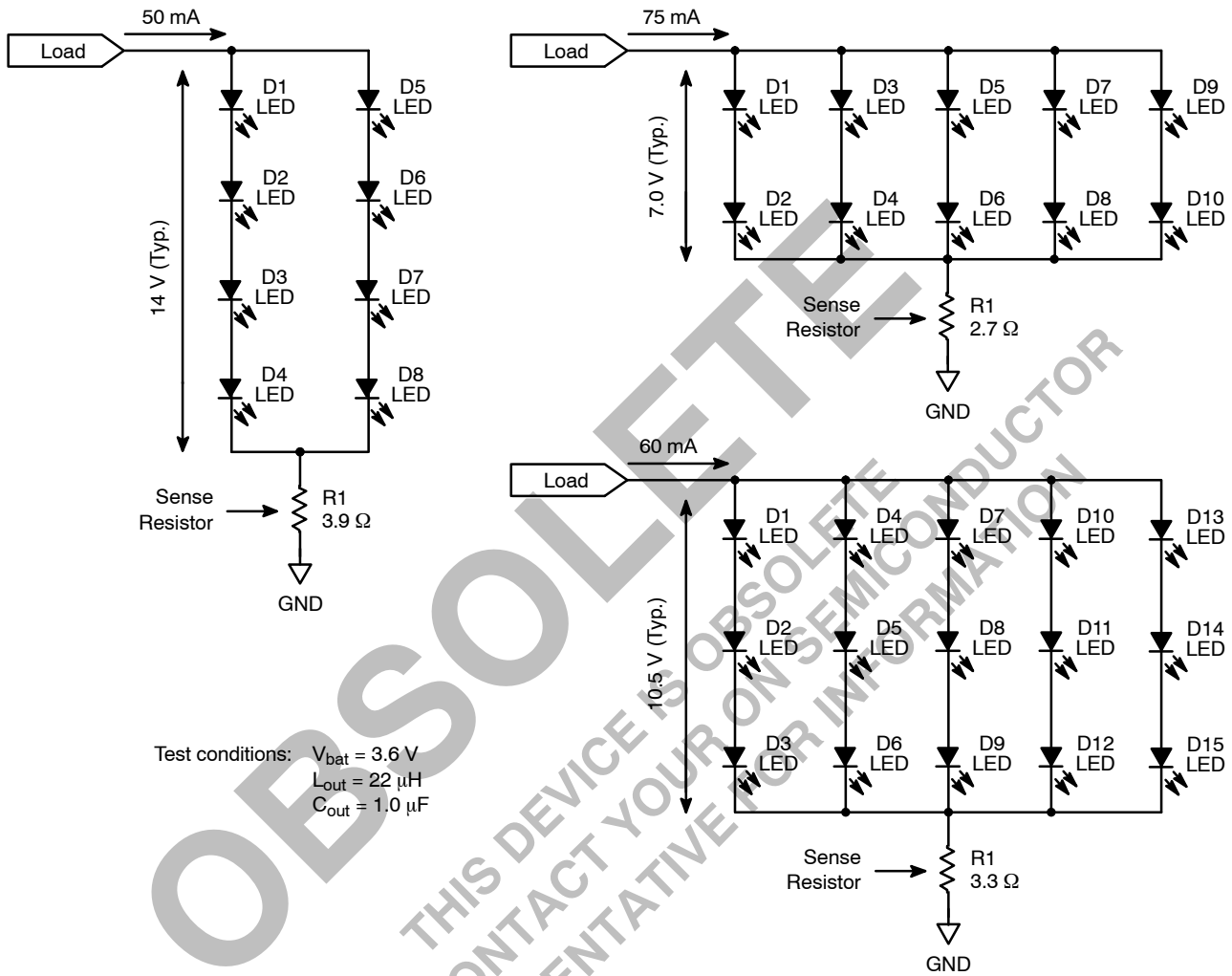
Table 1. Recommended Passive Parts

Part	Manufacturer	Description	Part Number
Ceramic Capacitor 1.0 $\mu\text{F}/16 \text{ V}$	MURATA	GRM42 – X7R	GRM42–6X7R–105K16
Ceramic Capacitor 1.0 $\mu\text{F}/25 \text{ V}$	MURATA	GRM42 – X5R	GRM
Ceramic Capacitor 4.7 $\mu\text{F}/6.3 \text{ V}$	MURATA	GRM40 – X5R	GRM40–X5R–475K6.3
Inductor 22 $\mu\text{H}$	CoilCraft	1008PS – Shielded	1008PS–223MC
Inductor 22 $\mu\text{H}$	CoilCraft	Power Wafer	LPQ4812–223KXC
Inductor 22 $\mu\text{H}$	WURTH	Power Choke	744031220
Inductor 22 $\mu\text{H}$	TDK	Power Inductor	VLP4614T–220MR40

**Typical LEDs Load Mapping**

Since the output power is voltage battery limited (see Figure 5), one shall arrange the LED to cope with a specific need. In particular, since the power cannot extend 600 mW

under realistic battery supply, powering ten LED can be achieved by a series/parallel combination as depicted in Figure 36.



**Figure 36. Examples of Possible LED Arrangements**

# NCP5005

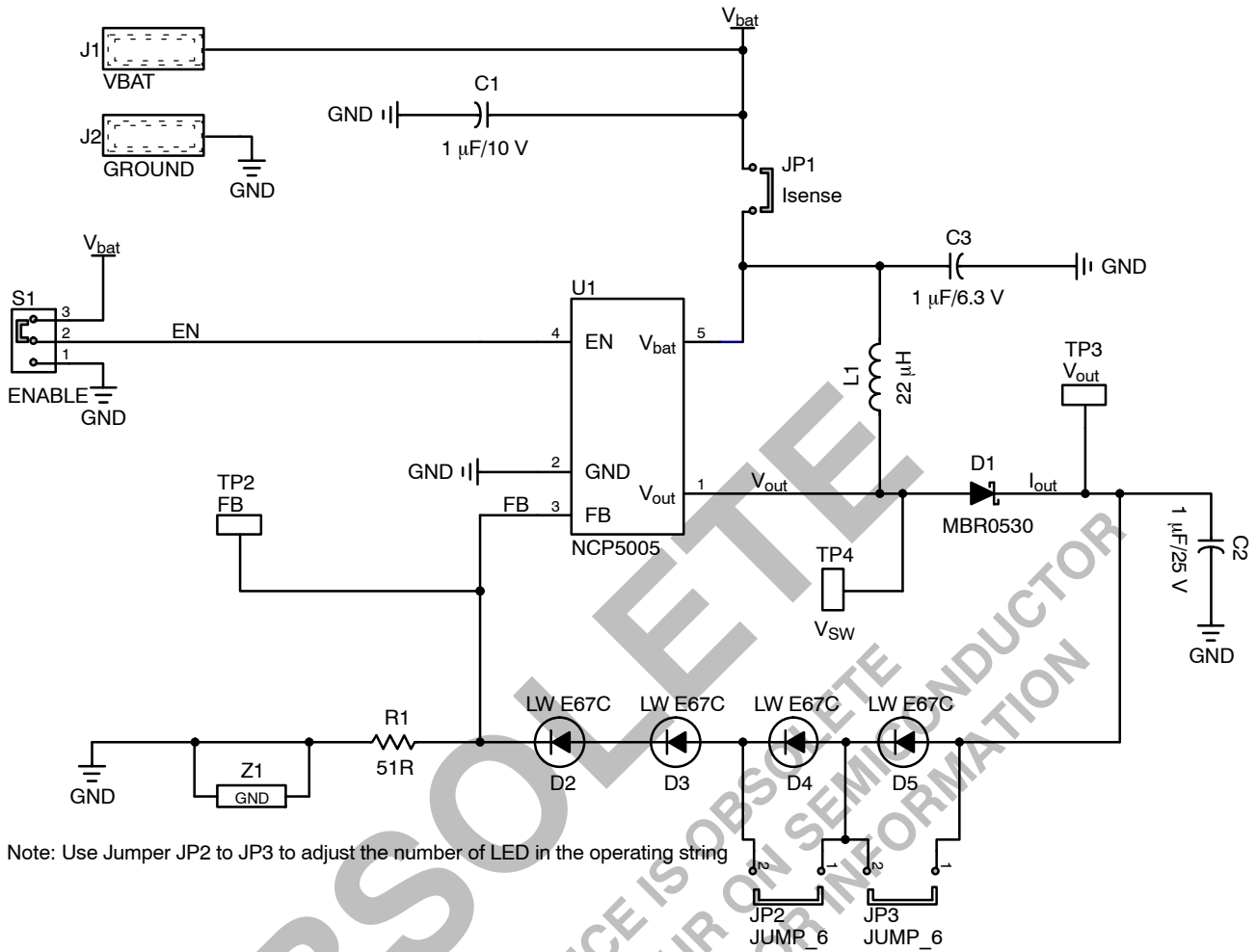


Figure 37. NCP5005 Demo Board Schematic Diagram

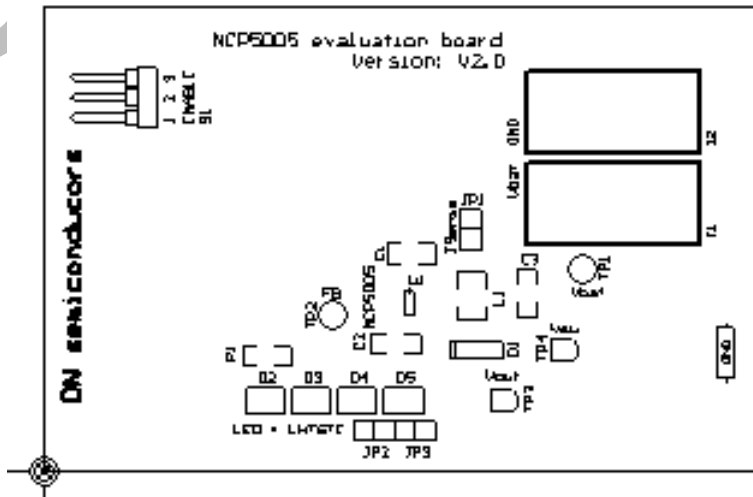


Figure 38. NCP5005 Demo Board Top Silkscreen

**FIGURES INDEX**

Figure 1: Typical Application ..... 2

Figure 2: Block Diagram ..... 2

Figure 3: Basic DC/DC Converter Structure ..... 5

Figure 4: Basic DC/DC Operation ..... 6

Figure 5: Maximum Output Power as a Function of the Battery Supply Voltage ..... 7

Figure 6: Typical Inductor Peak Current as a Function of  $V_{bat}$  Voltage ..... 7

Figure 7: Maximum Output Current as a Function of  $V_{bat}$  ..... 7

Figure 8: Output Current Feedback ..... 8

Figure 9: Basic Schematic Diagram ..... 8

Figure 10: Overall Efficiency vs. Power Supply @  $I_{out} = 4.0\text{ mA}$ ,  $L = 22\text{ }\mu\text{H}$  ..... 9

Figure 11: Overall Efficiency vs. Power Supply @  $I_{out} = 10\text{ mA}$ ,  $L = 22\text{ }\mu\text{H}$  ..... 9

Figure 12: Overall Efficiency vs. Power Supply @  $I_{out} = 15\text{ mA}$ ,  $L = 22\text{ }\mu\text{H}$  ..... 9

Figure 13: Overall Efficiency vs. Power Supply @  $I_{out} = 20\text{ mA}$ ,  $L = 22\text{ }\mu\text{H}$  ..... 9

Figure 14: Overall Efficiency vs. Power Supply @  $I_{out} = 40\text{ mA}$ ,  $L = 22\text{ }\mu\text{H}$  ..... 10

Figure 15: Feedback Voltage Stability ..... 10

Figure 16: Feedback Voltage Variation ..... 10

Figure 17: Standby Current ..... 10

Figure 18: Typical Operating Frequency ..... 10

Figure 19: Overvoltage Protection ..... 10

Figure 20: Typical Power Up Response ..... 11

Figure 21: Typical Start-Up Inductor Current and Output Voltage ..... 11

Figure 22: Typical Inductor Current ..... 12

Figure 23: Typical Output Voltage Ripple ..... 12

Figure 24: Typical Output Peak Voltage ..... 13

Figure 25: Efficiency as a Function of  $V_{bat}$  and Inductor ESR ..... 13

Figure 26: Noise Returned to the Battery ..... 14

Figure 27: Relative EMI Over 100 kHz–30 MHz Bandwidth ..... 14

Figure 28: Basic DC Current Mode Operation with Analog Feedback ..... 15

Figure 29: Basic DC Current Mode Operation with PWM Control ..... 16

Figure 30: Operation with Analog PWM,  $f = 10\text{ kHz}$ ,  $DC = 25\%$  ..... 16

Figure 31: Typical Semi-Pulsed Mode of Operation ..... 17

Figure 32: Operation @ PWM = 10 kHz,  $DC = 10\%$  ..... 17

Figure 33: Operation @ PWM = 10 kHz,  $DC = 25\%$  ..... 18

Figure 34: Magnified View of Operation @ PWM = 10 kHz,  $DC = 25\%$  ..... 18

Figure 35: Output Current as a Function of the Operating Conditions ..... 19

Figure 36: Examples of Possible LED Arrangements ..... 20

Figure 37: NCP5005 Demo Board Schematic Diagram ..... 21

Figure 38: NCP5005 Demo Board Top Silkscreen ..... 21

**NOTE CAPTIONS INDEX**

Note 1: This device series contains ESD protection and exceeds the following tests ..... 4

Note 2: The maximum package power dissipation limit must not be exceeded ..... 4

Note 3: Latch-up current maximum rating:  $\pm 100\text{ mA}$  per JEDEC standard: JESD78 ..... 4

Note 4: Moisture Sensivity Level (MSL): 1 per IPC/JEDEC standard: J-STD-020A ..... 4

Note 5: The overall tolerance depends upon the accuracy of the external resistor ..... 5

**ABBREVIATIONS**

EN	Enable
FB	Feed Back
POR	Power On Reset: Internal pulse to reset the chip when the power supply is applied

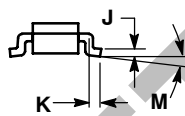
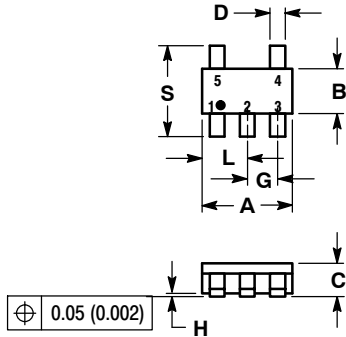
# NCP5005

## PACKAGE DIMENSIONS

TSOP-5  
SN SUFFIX  
CASE 483-02  
ISSUE C

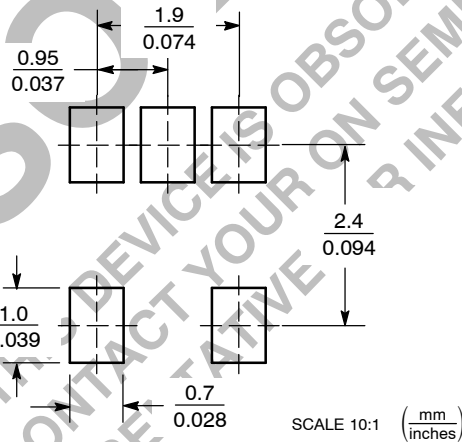
NOTES:

1. DIMENSIONING AND TOLERANCING PER ANSI Y14.5M, 1982.
2. CONTROLLING DIMENSION: MILLIMETER.
3. MAXIMUM LEAD THICKNESS INCLUDES LEAD FINISH THICKNESS. MINIMUM LEAD THICKNESS IS THE MINIMUM THICKNESS OF BASE MATERIAL.
4. A AND B DIMENSIONS DO NOT INCLUDE MOLD FLASH, PROTRUSIONS, OR GATE BURRS.



DIM	MILLIMETERS		INCHES	
	MIN	MAX	MIN	MAX
A	2.90	3.10	0.1142	0.1220
B	1.30	1.70	0.0512	0.0669
C	0.90	1.10	0.0354	0.0433
D	0.25	0.50	0.0098	0.0197
G	0.85	1.05	0.0335	0.0413
H	0.013	0.100	0.0005	0.0040
J	0.10	0.26	0.0040	0.0102
K	0.20	0.60	0.0079	0.0236
L	1.25	1.55	0.0493	0.0610
M	0	10	0	10
S	2.50	3.00	0.0985	0.1181

### SOLDERING FOOTPRINT\*



\*For additional information on our Pb-Free strategy and soldering details, please download the ON Semiconductor Soldering and Mounting Techniques Reference Manual, SOLDERRM/D.

ON Semiconductor and are registered trademarks of Semiconductor Components Industries, LLC (SCILLC). SCILLC reserves the right to make changes without further notice to any products herein. SCILLC makes no warranty, representation or guarantee regarding the suitability of its products for any particular purpose, nor does SCILLC assume any liability arising out of the application or use of any product or circuit, and specifically disclaims any and all liability, including without limitation special, consequential or incidental damages. "Typical" parameters which may be provided in SCILLC data sheets and/or specifications can and do vary in different applications and actual performance may vary over time. All operating parameters, including "Typicals" must be validated for each customer application by customer's technical experts. SCILLC does not convey any license under its patent rights nor the rights of others. SCILLC products are not designed, intended, or authorized for use as components in systems intended for surgical implant into the body, or other applications intended to support or sustain life, or for any other application in which the failure of the SCILLC product could create a situation where personal injury or death may occur. Should Buyer purchase or use SCILLC products for any such unintended or unauthorized application, Buyer shall indemnify and hold SCILLC and its officers, employees, subsidiaries, affiliates, and distributors harmless against all claims, costs, damages, and expenses, and reasonable attorney fees arising out of, directly or indirectly, any claim of personal injury or death associated with such unintended or unauthorized use, even if such claim alleges that SCILLC was negligent regarding the design or manufacture of the part. SCILLC is an Equal Opportunity/Affirmative Action Employer. This literature is subject to all applicable copyright laws and is not for resale in any manner.

### PUBLICATION ORDERING INFORMATION

**LITERATURE FULFILLMENT:**  
Literature Distribution Center for ON Semiconductor  
P.O. Box 61312, Phoenix, Arizona 85082-1312 USA  
**Phone:** 480-829-7710 or 800-344-3860 Toll Free USA/Canada  
**Fax:** 480-829-7709 or 800-344-3867 Toll Free USA/Canada  
**Email:** orderlit@onsemi.com

**N. American Technical Support:** 800-282-9855 Toll Free  
USA/Canada

**Japan:** ON Semiconductor, Japan Customer Focus Center  
2-9-1 Kamimeguro, Meguro-ku, Tokyo, Japan 153-0051  
**Phone:** 81-3-5773-3850

**ON Semiconductor Website:** <http://onsemi.com>

**Order Literature:** <http://www.onsemi.com/litorder>

For additional information, please contact your local Sales Representative.

NCP5005/D