

## Important notice

Dear Customer,

On 7 February 2017 the former NXP Standard Product business became a new company with the tradename **Nexperia**. Nexperia is an industry leading supplier of Discrete, Logic and PowerMOS semiconductors with its focus on the automotive, industrial, computing, consumer and wearable application markets

In data sheets and application notes which still contain NXP or Philips Semiconductors references, use the references to Nexperia, as shown below.

Instead of <http://www.nxp.com>, <http://www.philips.com/> or <http://www.semiconductors.philips.com/>, use <http://www.nexperia.com>

Instead of [sales.addresses@www.nxp.com](mailto:sales.addresses@www.nxp.com) or [sales.addresses@www.semiconductors.philips.com](mailto:sales.addresses@www.semiconductors.philips.com), use [salesaddresses@nexperia.com](mailto:salesaddresses@nexperia.com) (email)

Replace the copyright notice at the bottom of each page or elsewhere in the document, depending on the version, as shown below:

- © NXP N.V. (year). All rights reserved or © Koninklijke Philips Electronics N.V. (year). All rights reserved

Should be replaced with:

- © **Nexperia B.V. (year). All rights reserved.**

If you have any questions related to the data sheet, please contact our nearest sales office via e-mail or telephone (details via [salesaddresses@nexperia.com](mailto:salesaddresses@nexperia.com)). Thank you for your cooperation and understanding,

Kind regards,

Team Nexperia

**TrenchMOS™ transistor**  
**Logic level FET**

**PHT11N06LT**

**GENERAL DESCRIPTION**

N-channel enhancement mode logic level field-effect power transistor in a plastic envelope suitable for surface mounting. The device features very low on-state resistance and has integral zener diodes giving ESD protection. It is intended for use in DC-DC converters and general purpose switching applications.

**QUICK REFERENCE DATA**

SYMBOL	PARAMETER	MAX.	UNIT
$V_{DS}$	Drain-source voltage	55	V
$I_D$	Drain current (DC) $T_{sp} = 25\text{ °C}$	10.7	A
	Drain current (DC) $T_{amb} = 25\text{ °C}$	4.9	A
$P_{tot}$	Total power dissipation	8.3	W
$T_j$	Junction temperature	150	°C
$R_{DS(ON)}$	Drain-source on-state resistance $V_{GS} = 5\text{ V}$	40	mΩ

**PINNING - SOT223**

PIN	DESCRIPTION
1	gate
2	drain
3	source
4	drain (tab)

**PIN CONFIGURATION**

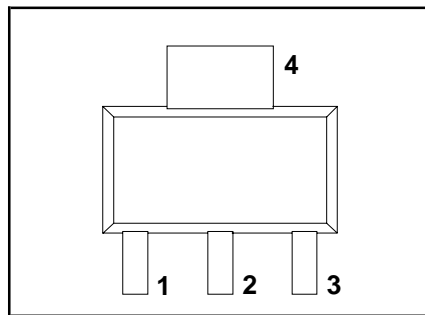

**SYMBOL**

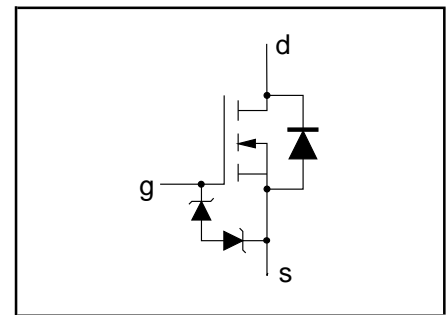

**LIMITING VALUES**

Limiting values in accordance with the Absolute Maximum System (IEC 134)

SYMBOL	PARAMETER	CONDITIONS	MIN.	MAX.	UNIT
$V_{DS}$	Drain-source voltage	-	-	55	V
$V_{DGR}$	Drain-gate voltage	$R_{GS} = 20\text{ k}\Omega$	-	55	V
$\pm V_{GS}$	Gate-source voltage	-	-	13	V
$I_D$	Drain current (DC)	$T_{sp} = 25\text{ °C}$	-	10.7	A
		$T_{amb} = 25\text{ °C}$	-	4.9	A
$I_D$	Drain current (DC)	$T_{sp} = 100\text{ °C}$	-	7.5	A
		$T_{amb} = 100\text{ °C}$	-	3.4	A
$I_{DM}$	Drain current (pulse peak value)	$T_{sp} = 25\text{ °C}$	-	42	A
		$T_{amb} = 25\text{ °C}$	-	19	A
$P_{tot}$	Total power dissipation	$T_{sp} = 25\text{ °C}$	-	8.3	W
		$T_{amb} = 25\text{ °C}$	-	1.8	W
$T_{stg}, T_j$	Storage & operating temperature	-	- 55	150	°C

**ESD LIMITING VALUE**

SYMBOL	PARAMETER	CONDITIONS	MIN.	MAX.	UNIT
$V_C$	Electrostatic discharge capacitor voltage	Human body model (100 pF, 1.5 kΩ)	-	2	kV

# TrenchMOS™ transistor

## Logic level FET

PHT11N06LT

### THERMAL RESISTANCES

SYMBOL	PARAMETER	CONDITIONS	TYP.	MAX.	UNIT
$R_{th\ j-sp}$	From junction to solder point	Mounted on any PCB	12	15	K/W
$R_{th\ j-amb}$	From junction to ambient	Mounted on PCB of Fig.18	-	70	K/W

### STATIC CHARACTERISTICS

$T_j = 25^\circ\text{C}$  unless otherwise specified

SYMBOL	PARAMETER	CONDITIONS	MIN.	TYP.	MAX.	UNIT
$V_{(BR)DSS}$	Drain-source breakdown voltage	$V_{GS} = 0\text{ V}; I_D = 0.25\text{ mA}$ $T_j = -55^\circ\text{C}$	55 50	- -	- -	V V
$V_{GS(TO)}$	Gate threshold voltage	$V_{DS} = V_{GS}; I_D = 1\text{ mA}$ $T_j = 150^\circ\text{C}$ $T_j = -55^\circ\text{C}$	1.0 0.6	1.5 -	2.0 -	V V
$I_{DSS}$	Zero gate voltage drain current	$V_{DS} = 55\text{ V}; V_{GS} = 0\text{ V};$ $T_j = 150^\circ\text{C}$	-	0.05	10	$\mu\text{A}$
$I_{GSS}$	Gate source leakage current	$V_{GS} = \pm 5\text{ V}$ $T_j = 150^\circ\text{C}$	-	0.02	1	$\mu\text{A}$
$\pm V_{(BR)GSS}$	Gate source breakdown voltage	$I_G = \pm 1\text{ mA}$ $T_j = 150^\circ\text{C}$	10	-	5	V $\mu\text{A}$
$R_{DS(ON)}$	Drain-source on-state resistance	$V_{GS} = 5\text{ V}; I_D = 5\text{ A}$ $T_j = 150^\circ\text{C}$	-	30	40	m $\Omega$ m $\Omega$

### DYNAMIC CHARACTERISTICS

$T_{mb} = 25^\circ\text{C}$  unless otherwise specified

SYMBOL	PARAMETER	CONDITIONS	MIN.	TYP.	MAX.	UNIT
$g_{fs}$	Forward transconductance	$V_{DS} = 25\text{ V}; I_D = 5\text{ A}; T_j = 25^\circ\text{C}$	11	19	-	S
$Q_{g(tot)}$	Total gate charge	$I_D = 9\text{ A}; V_{DD} = 44\text{ V}; V_{GS} = 5\text{ V}$	-	17	-	nC
$Q_{gs}$	Gate-source charge		-	3.5	-	nC
$Q_{gd}$	Gate-drain (Miller) charge		-	10	-	nC
$C_{iss}$	Input capacitance	$V_{GS} = 0\text{ V}; V_{DS} = 25\text{ V}; f = 1\text{ MHz}$	-	1050	1400	pF
$C_{oss}$	Output capacitance		-	205	245	pF
$C_{rss}$	Feedback capacitance		-	110	150	pF
$t_{don}$	Turn-on delay time	$V_{DD} = 30\text{ V}; I_D = 9\text{ A};$ $V_{GS} = 5\text{ V}; R_G = 10\ \Omega;$ $T_j = 25^\circ\text{C}$	-	17	25	ns
$t_r$	Turn-on rise time		-	65	100	ns
$t_{doff}$	Turn-off delay time		-	70	105	ns
$t_f$	Turn-off fall time		-	70	105	ns

### REVERSE DIODE LIMITING VALUES AND CHARACTERISTICS

$T_j = -55$  to  $175^\circ\text{C}$  unless otherwise specified

SYMBOL	PARAMETER	CONDITIONS	MIN.	TYP.	MAX.	UNIT
$I_{DR}$	Continuous reverse drain current	$T_{sp} = 25^\circ\text{C}$	-	-	10.7	A
$I_{DRM}$	Pulsed reverse drain current	$T_{sp} = 25^\circ\text{C}$	-	-	40	A
$V_{SD}$	Diode forward voltage	$I_F = 5\text{ A}; V_{GS} = 0\text{ V}$	-	0.85	1.1	V
$t_{rr}$	Reverse recovery time	$I_F = 5\text{ A}; -di_F/dt = 100\text{ A}/\mu\text{s};$ $V_{GS} = -10\text{ V}; V_R = 30\text{ V}$	-	45	-	ns
$Q_{rr}$	Reverse recovery charge		-	.3	-	$\mu\text{C}$

---

TrenchMOS™ transistor  
Logic level FET

---

PHT11N06LT

**AVALANCHE LIMITING VALUE**

SYMBOL	PARAMETER	CONDITIONS	MIN.	TYP.	MAX.	UNIT
$W_{DSS}$	Drain-source non-repetitive unclamped inductive turn-off energy	$I_D = 3.6 \text{ A}; V_{DD} \leq 25 \text{ V};$ $V_{GS} = 5 \text{ V}; R_{GS} = 50 \Omega; T_{sp} = 25 \text{ }^\circ\text{C}$	-	-	60	mJ

TrenchMOS™ transistor  
Logic level FET

PHT11N06LT

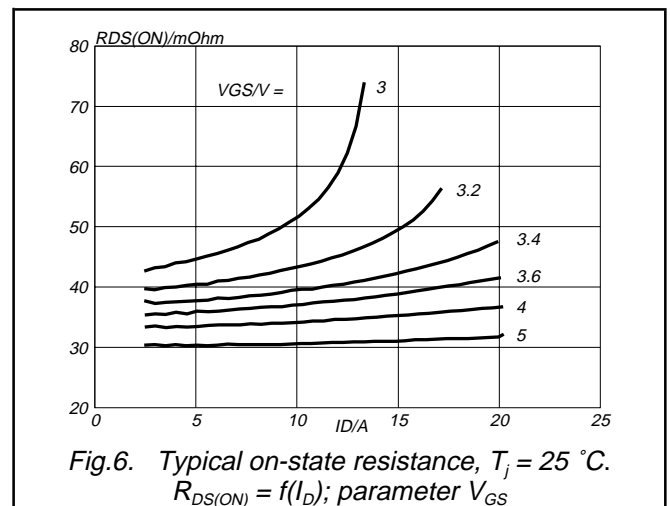
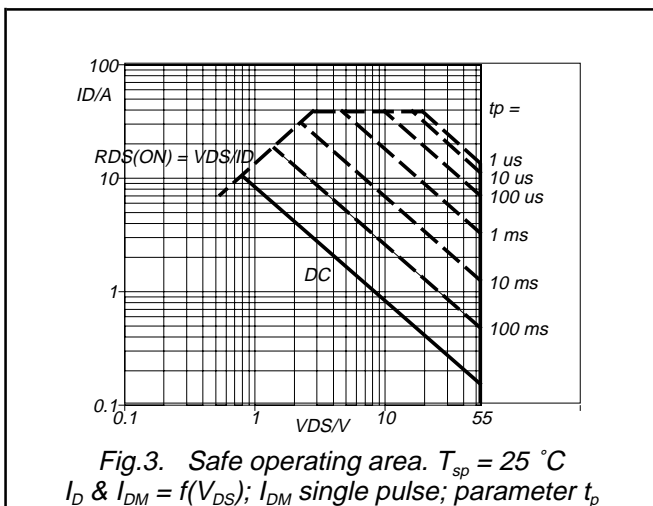
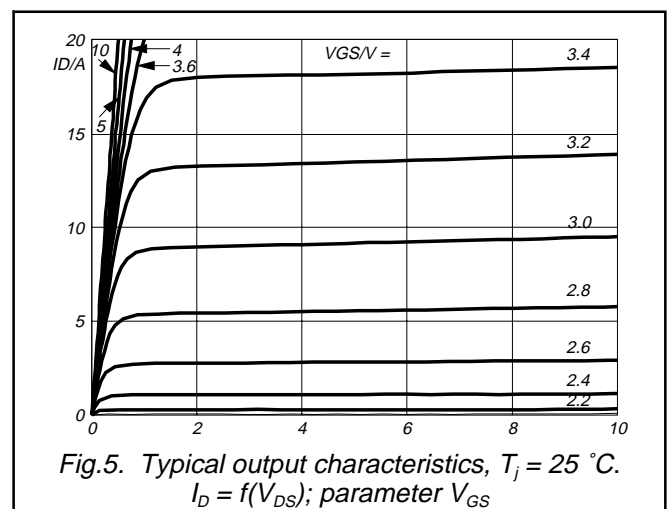
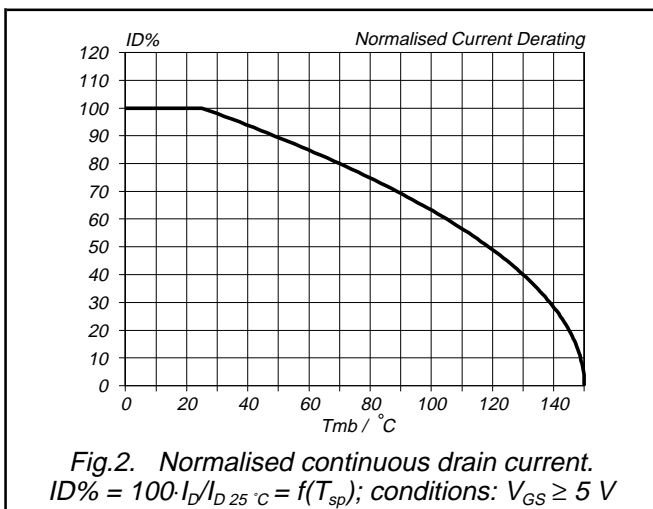
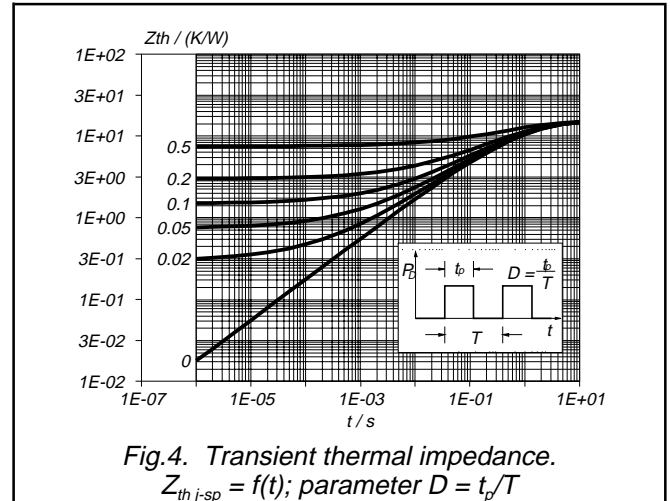
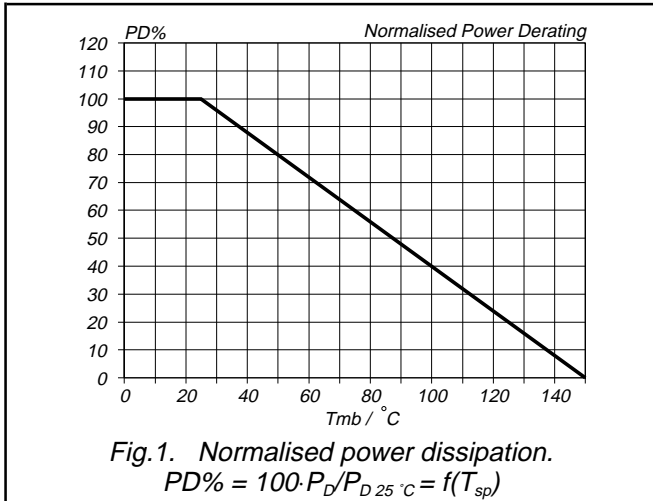

TrenchMOS™ transistor  
Logic level FET

PHT11N06LT

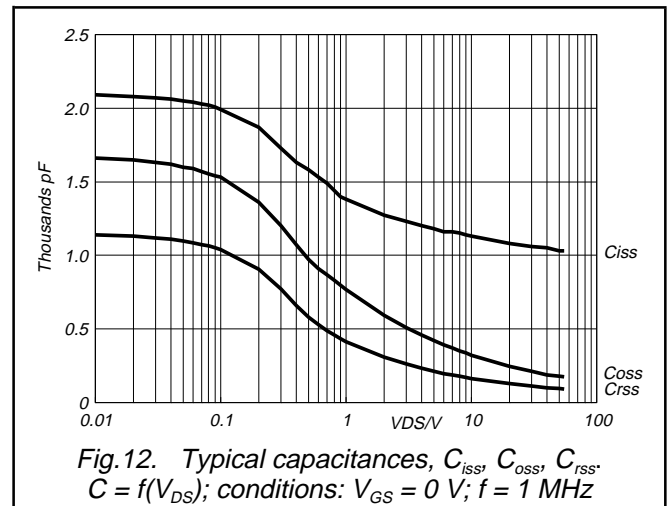
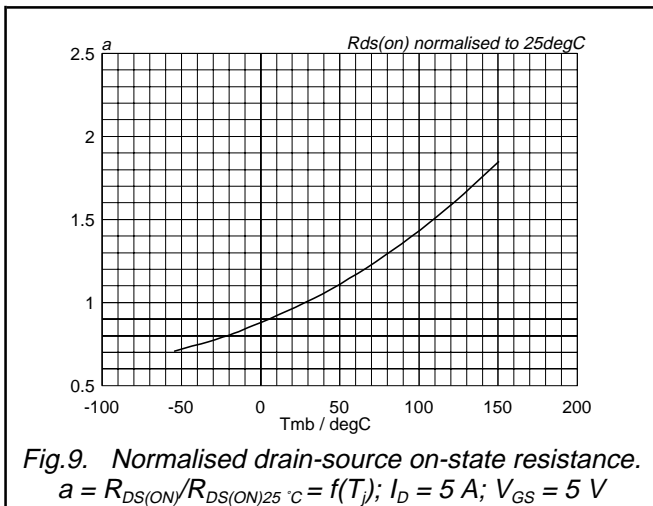
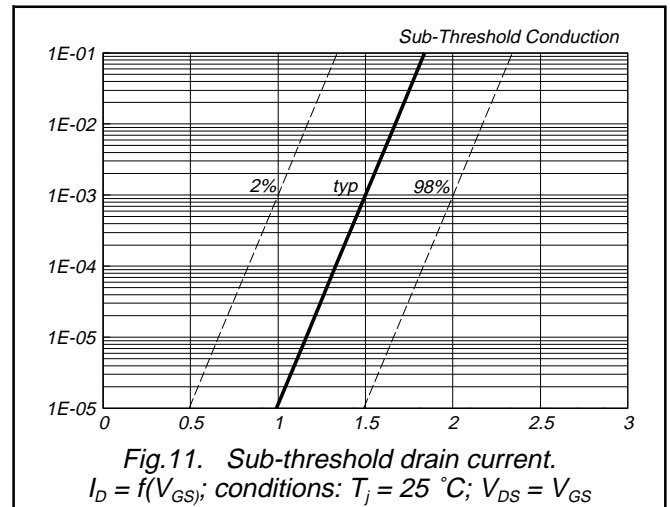
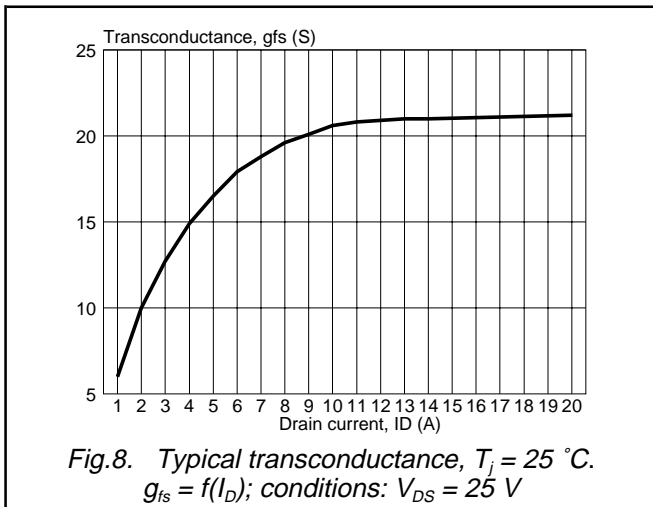
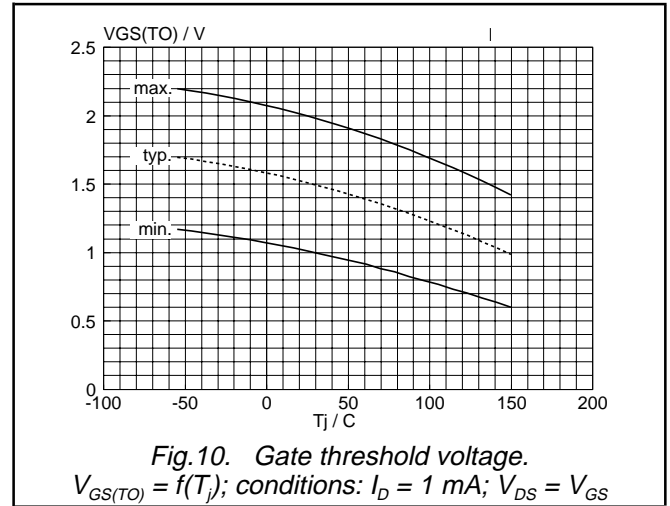
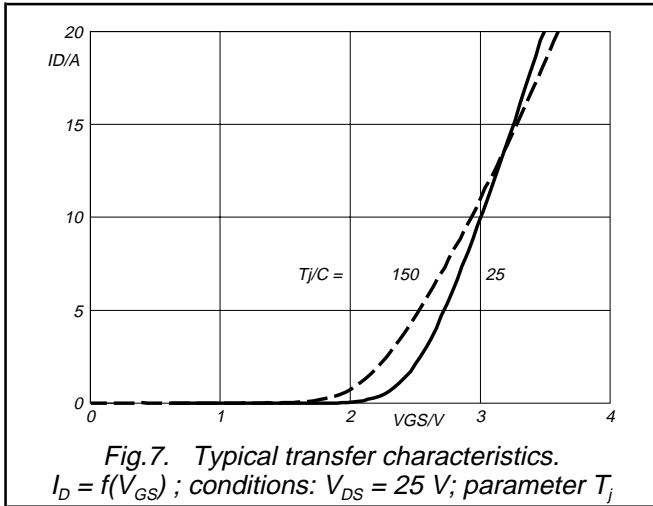

TrenchMOS™ transistor  
Logic level FET

PHT11N06LT

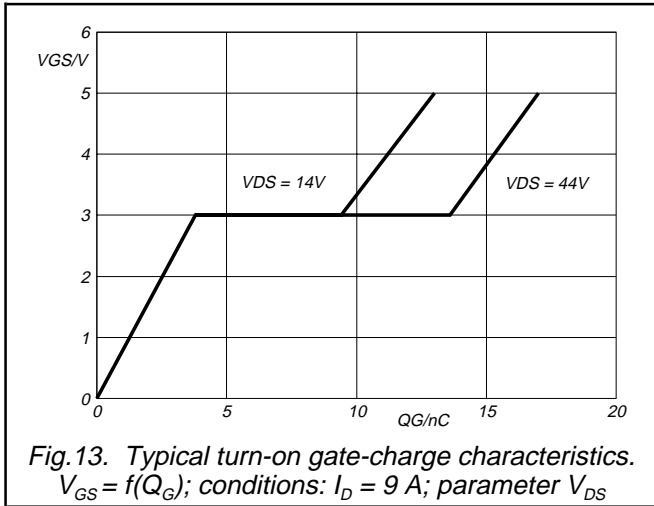

Fig.13. Typical turn-on gate-charge characteristics.  
 $V_{GS} = f(Q_G)$ ; conditions:  $I_D = 9\text{ A}$ ; parameter  $V_{DS}$

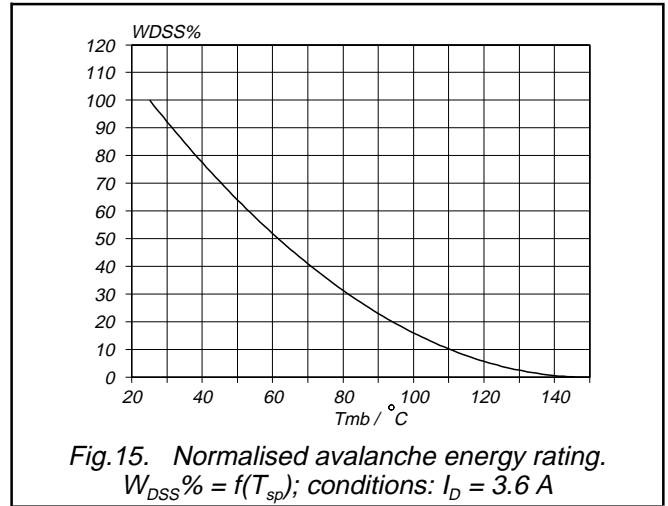

Fig.15. Normalised avalanche energy rating.  
 $W_{DSS}\% = f(T_{sp})$ ; conditions:  $I_D = 3.6\text{ A}$

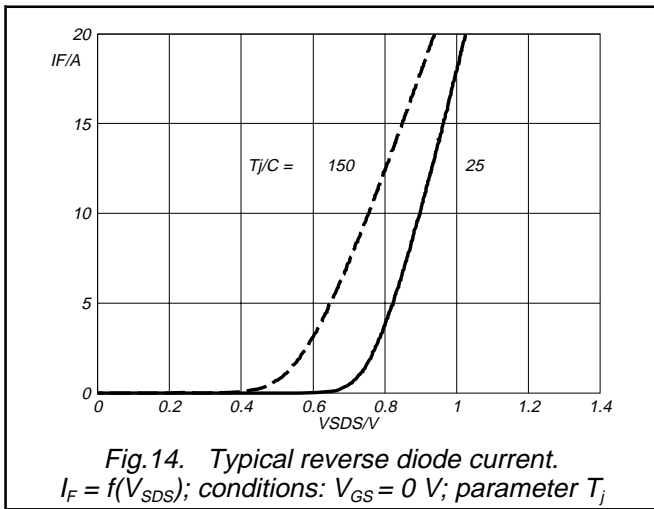

Fig.14. Typical reverse diode current.  
 $I_F = f(V_{SDS})$ ; conditions:  $V_{GS} = 0\text{ V}$ ; parameter  $T_j$

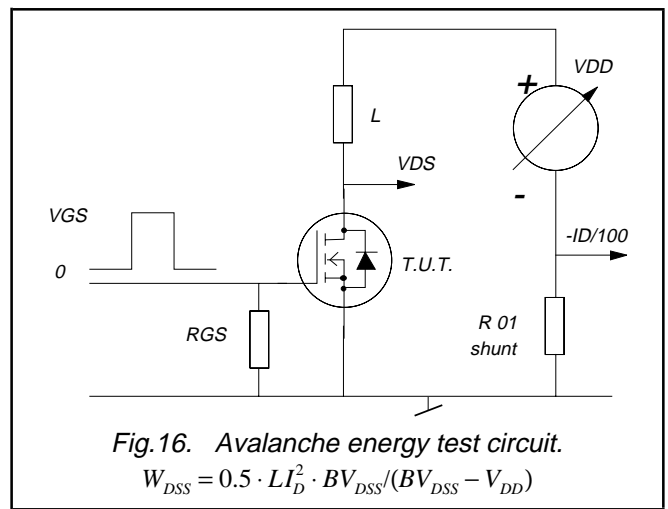
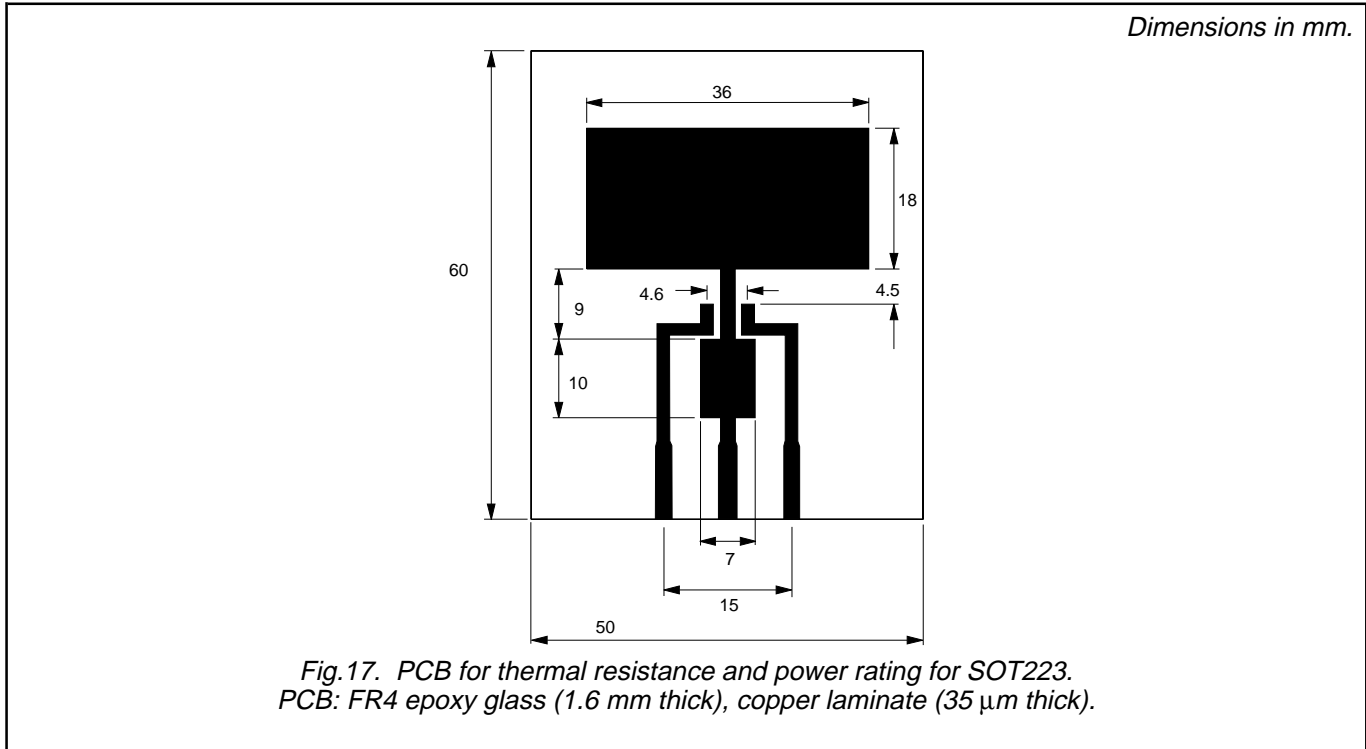

Fig.16. Avalanche energy test circuit.  
 $W_{DSS} = 0.5 \cdot L I_D^2 \cdot BV_{DSS} / (BV_{DSS} - V_{DD})$

TrenchMOS™ transistor  
Logic level FET

PHT11N06LT

PRINTED CIRCUIT BOARD





TrenchMOS™ transistor  
Logic level FET

PHT11N06LT

**MECHANICAL DATA**

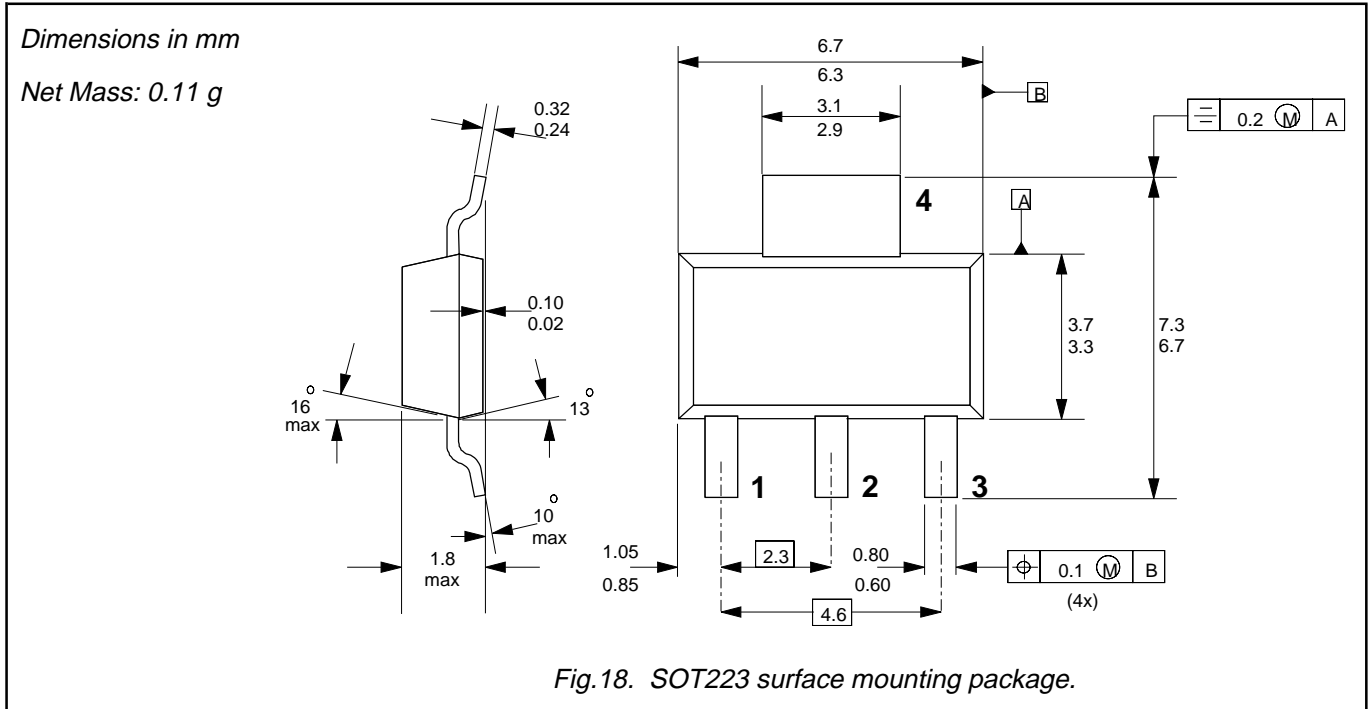

**Notes**

1. Observe the general handling precautions for electrostatic-discharge sensitive devices (ESDs) to prevent damage to MOS gate oxide.
2. Refer to surface mounting instructions for SOT223 envelope.
3. Epoxy meets UL94 V0 at 1/8".

## TrenchMOS™ transistor Logic level FET

PHT11N06LT

### DEFINITIONS

<b>Data sheet status</b>	
Objective specification	This data sheet contains target or goal specifications for product development.
Preliminary specification	This data sheet contains preliminary data; supplementary data may be published later.
Product specification	This data sheet contains final product specifications.
<b>Limiting values</b>	
Limiting values are given in accordance with the Absolute Maximum Rating System (IEC 134). Stress above one or more of the limiting values may cause permanent damage to the device. These are stress ratings only and operation of the device at these or at any other conditions above those given in the Characteristics sections of this specification is not implied. Exposure to limiting values for extended periods may affect device reliability.	
<b>Application information</b>	
Where application information is given, it is advisory and does not form part of the specification.	
<b>© Philips Electronics N.V. 1998</b>	
All rights are reserved. Reproduction in whole or in part is prohibited without the prior written consent of the copyright owner.	
The information presented in this document does not form part of any quotation or contract, it is believed to be accurate and reliable and may be changed without notice. No liability will be accepted by the publisher for any consequence of its use. Publication thereof does not convey nor imply any license under patent or other industrial or intellectual property rights.	

### LIFE SUPPORT APPLICATIONS

These products are not designed for use in life support appliances, devices or systems where malfunction of these products can be reasonably expected to result in personal injury. Philips customers using or selling these products for use in such applications do so at their own risk and agree to fully indemnify Philips for any damages resulting from such improper use or sale.