

Important notice

Dear Customer,

On 7 February 2017 the former NXP Standard Product business became a new company with the tradename **Nexperia**. Nexperia is an industry leading supplier of Discrete, Logic and PowerMOS semiconductors with its focus on the automotive, industrial, computing, consumer and wearable application markets

In data sheets and application notes which still contain NXP or Philips Semiconductors references, use the references to Nexperia, as shown below.

Instead of <http://www.nxp.com>, <http://www.philips.com/> or <http://www.semiconductors.philips.com/>, use <http://www.nexperia.com>

Instead of sales.addresses@www.nxp.com or sales.addresses@www.semiconductors.philips.com, use salesaddresses@nexperia.com (email)

Replace the copyright notice at the bottom of each page or elsewhere in the document, depending on the version, as shown below:

- © NXP N.V. (year). All rights reserved or © Koninklijke Philips Electronics N.V. (year). All rights reserved

Should be replaced with:

- © **Nexperia B.V. (year). All rights reserved.**

If you have any questions related to the data sheet, please contact our nearest sales office via e-mail or telephone (details via salesaddresses@nexperia.com). Thank you for your cooperation and understanding,

Kind regards,

Team Nexperia

BUK212-50Y; BUK217-50Y

Single channel high-side TOPFET™

Rev. 01 — 17 March 2003

Product data

1. Product profile

1.1 Description

Monolithic temperature and overload protected single high-side power switch based on TOPFET™ Trench technology in a 5-pin surface mount or leadform plastic package.

Product availability:

BUK212-50Y in SOT263B-01

BUK217-50Y in SOT426 (D²-PAK).

1.2 Features

- Very low quiescent current
- Power TrenchMOS™
- Overtemperature protection
- Over and undervoltage protection
- Reverse battery protection
- Low charge pump noise
- Loss of ground protection
- CMOS logic capability
- Negative load clamping
- Overload protection
- ESD protection for all pins
- Diagnostic status indication
- Operating voltage down to 5.5 V
- Current limitation.

1.3 Applications

- 12 V and 24 V grounded loads
- Inductive loads
- High inrush current loads
- Replacement for relays and fuses.

1.4 Quick reference data

Table 1: Quick reference data

Symbol	Parameter	Min	Max	Unit
R_{BLon}	battery-load on-state resistance	-	14	mΩ
I_L	load current	-	44	A
$I_{L(nom)}$	nominal load current (ISO)	25	-	A
$I_{L(lim)}$	self-limiting load current	47	100	A
$V_{BG(oper)}$	battery-ground operating voltage	5.5	35	V



PHILIPS

2. Pinning information

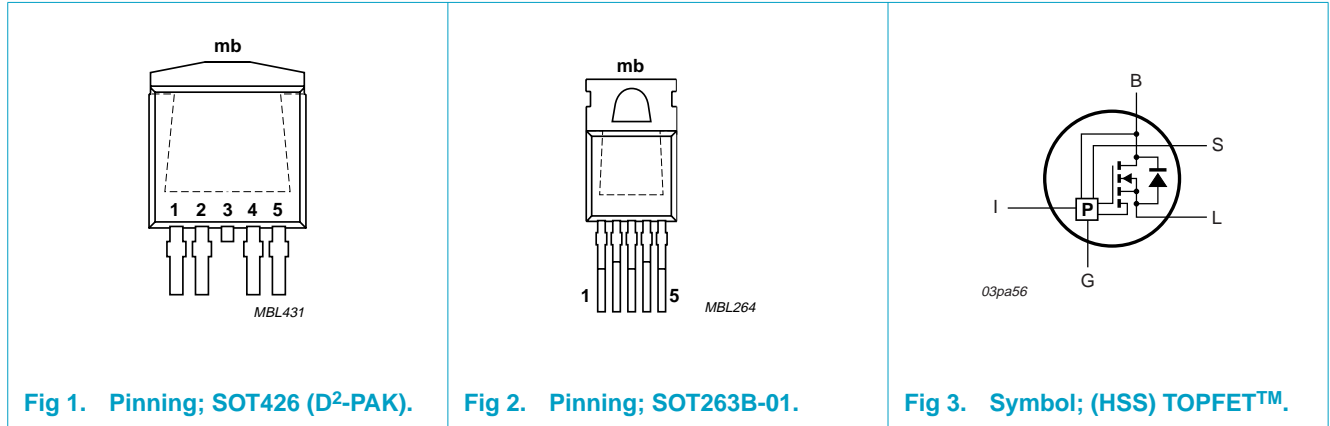

Fig 1. Pinning; SOT426 (D²-PAK).

Fig 2. Pinning; SOT263B-01.

Fig 3. Symbol; (HSS) TOPFET™.

2.1 Pin description

Table 2: Pin description

Symbol	Pin	I/O	Description
G	1	-	circuit common ground
I	2	I	input
B	3	-	[1] [2] battery
S	4	O	status
L	5	O	load
-	mb	-	[2] mounting base

[1] It is not possible to make a connection to pin 3 of the SOT426 package.

[2] The battery is connected to the mounting base.

3. Block diagram

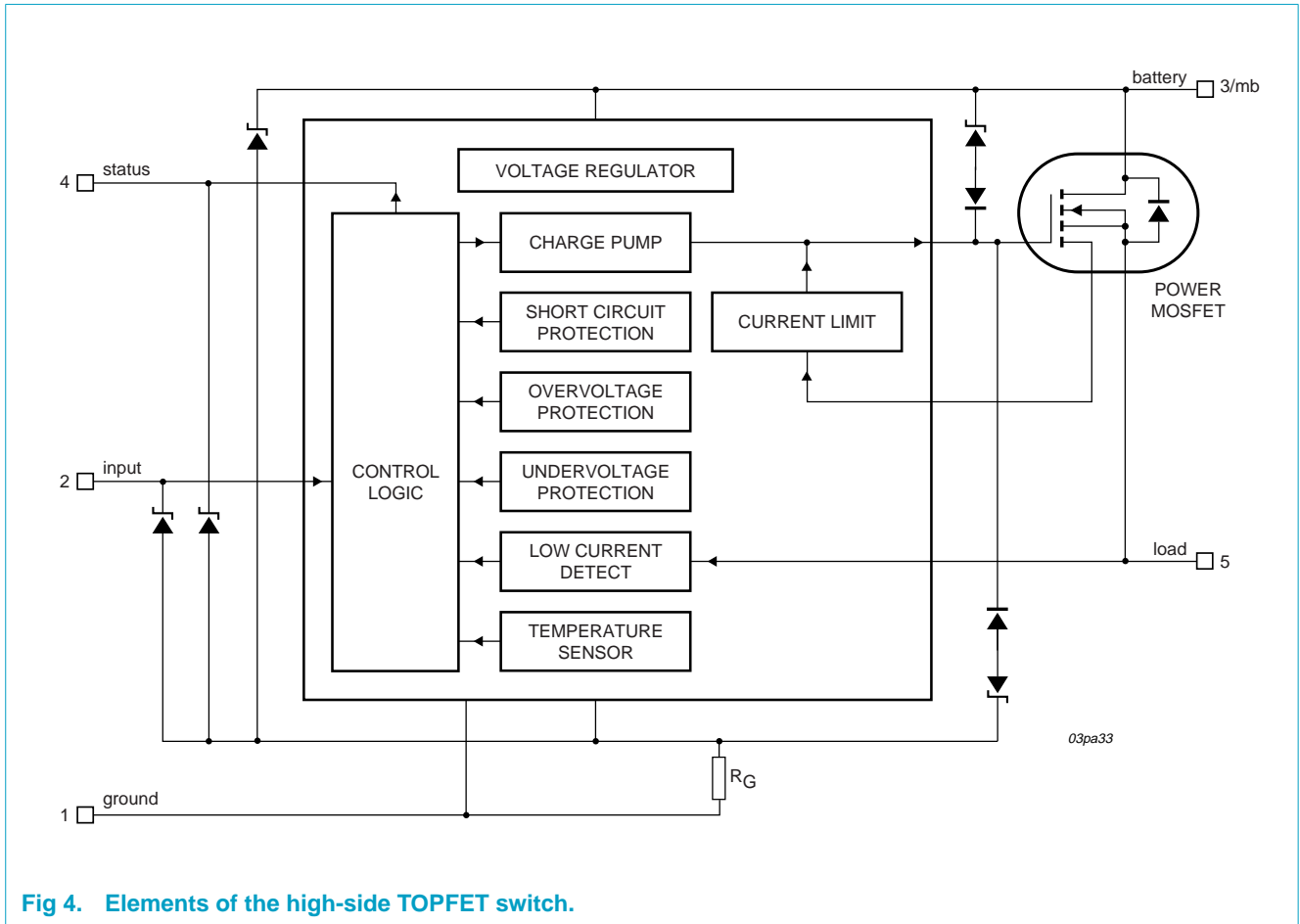

Fig 4. Elements of the high-side TOPFET switch.

4. Functional description

Table 3: Truth table

Abbreviations: L = logic LOW; H = logic HIGH; X = don't care; 0 = condition not present; 1 = condition present; UV = undervoltage; OV = overvoltage; LC = low current or open circuit load; SC = short circuit; OT = overtemperature [1].

Input	Supply		Load			Load output	Status	Operating mode
	UV	OV	LC	SC	OT			
L	X	X	X	X	X	OFF	H	off
H	0	0	0	0	0	ON	H	on & normal
H	0	0	1	0	0	ON	L	on & low current detect
H	1	0	X	X	X	OFF	H	supply undervoltage lockout
H	0	1	X	0	0	OFF	H	supply overvoltage shutdown
H	0	0	0	1	X	OFF	L	SC tripped
H	0	0	0	0	1	OFF	L	OT shutdown

[1] The status will continue to indicate OT (even if the input goes LOW) until the device cools below the reset threshold. See "Overtemperature protection" characteristics in Table 6.

5. Limiting values

Table 4: Limiting values

In accordance with the Absolute Maximum Rating System (IEC 60134).

Symbol	Parameter	Conditions	Min	Max	Unit	
V _{BG}	battery-ground supply voltage		-	50	V	
I _L	load current	T _{mb} ≤ 90 °C	-	44	A	
P _{tot}	total power dissipation	T _{mb} ≤ 25 °C	-	115	W	
T _{stg}	storage temperature		-55	+175	°C	
T _j	junction temperature		-	+150	°C	
T _{mb}	mounting base temperature	during soldering (≤ 10 s)	-	260	°C	
Reverse battery voltage						
V _{BGR}	reverse battery-ground supply voltage		[1]	-	16	V
V _{BGRR}	repetitive reverse battery-ground supply voltage		-	32	V	
External resistor						
R _I	input resistor		[2]	3.3	-	kΩ
R _S	status resistor		[3]	3.3	-	kΩ
Input current						
I _I	input current		-5	+5	mA	
I _{IRM}	repetitive peak input current	δ ≤ 0.1; t _p = 300 μs	-50	+50	mA	
Status current						
I _S	status current		-5	+5	mA	
I _{SRM}	repetitive peak status current	δ ≤ 0.1; t _p = 300 μs	-50	+50	mA	
Inductive load clamping						
E _{BL(CL)S}	non-repetitive battery-load clamping energy	T _j = 150 °C prior to turn-off; I _L = 20 A	-	460	mJ	
Electrostatic discharge						
V _{esd}	electrostatic discharge voltage	Human body model; C = 100 pF; R = 1.5 kΩ	-	2	kV	

[1] Reverse battery voltage is only allowed with external resistors to limit the input and status currents to a safe value. The connected load must limit the reverse current. The internal ground resistor limits the reverse battery ground current.

[2] To limit input current during reverse battery and transient overvoltages.

[3] To limit status current during reverse battery and transient overvoltages.

6. Thermal characteristics

Table 5: Thermal characteristics

Symbol	Parameter	Conditions	Min	Typ	Max	Unit
R _{th(j-mb)}	thermal resistance from junction to mounting base		-	0.86	1.08	K/W
R _{th(j-a)}	thermal resistance from junction to ambient	mounted on printed circuit board; minimum footprint; SOT426	-	50	-	K/W

7. Static characteristics

Table 6: Static characteristics

Limits are valid for $-40\text{ °C} \leq T_{mb} \leq +150\text{ °C}$ and typical values for $T_{mb} = 25\text{ °C}$ unless otherwise specified.

Symbol	Parameter	Conditions	Min	Typ	Max	Unit
Clamping voltage						
$V_{BG(CL)}$	battery-ground clamping voltage	$I_G = 1\text{ mA}$; Figure 6	50	55	65	V
$V_{BL(CL)}$	battery-load clamping voltage	$I_L = I_G = 1\text{ mA}$	50	55	65	V
$V_{LG(CL)}$	load-ground clamping voltage	$I_L = 10\text{ mA}$; Figure 12 and 14	-18	-23	-28	V
		$I_L = 20\text{ A}$; $t_p = 300\text{ }\mu\text{s}$	[1] -20	-25	-30	V
Supply voltage						
$V_{BG(oper)}$	battery-ground operating voltage		5.5	-	35	V
Current						
I_B	battery quiescent current	$V_{LG} = 0\text{ V}$; Figure 10	[2] -	-	20	μA
		$T_{mb} = 150\text{ °C}$	-	-	20	μA
		$T_{mb} = 25\text{ °C}$	-	0.1	2	μA
$I_{L(off)}$	off-state load current	$V_{BL} = V_{BG}$	-	-	20	μA
		$T_{mb} = 150\text{ °C}$	-	-	20	μA
		$T_{mb} = 25\text{ °C}$	-	0.1	1	μA
$I_{G(on)}$	operating current	Figure 6	-	2	4	mA
$I_{L(nom)}$	nominal load current (ISO)	$V_{BL} = 0.5\text{ V}$; $T_{mb} = 85\text{ °C}$	[3] 25	-	-	A
Resistance [4]						
R_{BLon}	battery-load on-state resistance	$9\text{ V} \leq V_{BG} \leq 35\text{ V}$; $I_L = 20\text{ A}$; Figure 5	-	10	14	m Ω
		$T_{mb} = 25\text{ °C}$	-	-	25	m Ω
		$T_{mb} = 150\text{ °C}$	-	-	25	m Ω
		$V_{BG} = 6\text{ V}$; $I_L = 20\text{ A}$	-	13	18	m Ω
		$T_{mb} = 25\text{ °C}$	-	-	33	m Ω
$T_{mb} = 150\text{ °C}$	-	-	33	m Ω		
R_G	ground resistance	$I_G = 10\text{ mA}$	[5] 95	150	190	Ω
Input [6]						
I_I	input current	$V_{IG} = 5\text{ V}$	20	90	160	μA
$V_{IG(CL)}$	input-ground clamping voltage	$I_I = 200\text{ }\mu\text{A}$	5.5	7	8.5	V
$V_{IG(on)}$	input-ground turn-on voltage	Figure 9	-	2.4	3	V
$V_{IG(off)}$	input-ground turn-off voltage		1.5	2.1	-	V
$V_{IG(on)(hys)}$	input-ground turn-on hysteresis		-	0.3	-	V
$I_{I(on)}$	input turn-on current	$V_{IG} = 3\text{ V}$	-	-	100	μA
$I_{I(off)}$	input turn-off current	$V_{IG} = 1.5\text{ V}$	10	-	-	μA
Low current detection [7][10]						
$I_{L(LC)}$	load low current detect	$-40\text{ °C} \leq T_{mb} \leq +150\text{ °C}$	0.55	-	4.4	A
		$T_{mb} = 25\text{ °C}$; Figure 15	0.65	1.8	2.9	A
$I_{L(LC)(hys)}$	load low current detect hysteresis		-	0.44	-	A

Table 6: Static characteristics...continuedLimits are valid for $-40\text{ °C} \leq T_{mb} \leq +150\text{ °C}$ and typical values for $T_{mb} = 25\text{ °C}$ unless otherwise specified.

Symbol	Parameter	Conditions	Min	Typ	Max	Unit
Undervoltage [10]						
$V_{BG(uv)}$	battery-ground undervoltage		[8] 2	4.2	5.5	V
$V_{BG(uv)(hys)}$	battery-ground undervoltage hysteresis		-	0.5	-	V
Overvoltage [10]						
$V_{BG(ov)}$	battery-ground overvoltage		[9] 35	45	50	V
$V_{BG(ov)(hys)}$	battery-ground overvoltage hysteresis		-	1	-	V
Overload protection [10]						
$I_{L(lim)}$	self-limiting load current	$V_{BG} \geq 9\text{ V}$; $V_{BL} = V_{BG}$; Figure 8	[11] 47	74	100	A
Short circuit load protection [10][11]						
$V_{BL(off)}$	battery-load turn-off voltage	$V_{BG} = 16\text{ V}$; Figure 11	[12] 8	10	12	V
		$V_{BG} = 35\text{ V}$	15	20	25	V
Overtemperature protection [10][11]						
$T_{j(th)}$	threshold junction temperature		[13] 150	170	190	°C
$T_{j(th)(hys)}$	threshold junction temperature hysteresis		-	10	-	°C
Status [6][10]						
$V_{SG(CL)}$	status-ground clamping voltage	$I_S = 100\text{ }\mu\text{A}$	5.5	7	8.5	V
$V_{SG(L)}$	status-ground low voltage	$I_S = 100\text{ }\mu\text{A}$; Figure 7				
		$T_{mb} = -40\text{ °C}$	-	-	1	V
		$T_{mb} = 25\text{ °C}$	-	0.7	0.8	V
$I_{S(off)}$	status leakage current	$V_{SG} = 5\text{ V}$				
		$T_{mb} = 150\text{ °C}$	-	-	15	μA
		$T_{mb} = 25\text{ °C}$	-	0.1	1	μA
R_S	status resistor	connected externally; $V_{SG} = 5\text{ V}$	[14] -	47	-	k Ω

[1] For a high-side switch, the load pin voltage goes negative with respect to ground during the turn-off of an inductive load.

[2] This is the current drawn from the supply when the input is LOW, and includes leakage current to the load.

[3] Defined as in ISO 10483-1. For comparison purposes only.

[4] The supply and input voltages for the R_{BLon} tests are continuous. The specified pulse duration is $t_p = 300\text{ }\mu\text{s}$, and refers only to the applied load current.

[5] R_G is a resistor incorporated internally in the package.

[6] $9\text{ V} \leq V_{BG} \leq 16\text{ V}$

[7] $9\text{ V} \leq V_{BG} \leq 35\text{ V}$. A low current load can be detected in the on-state.

[8] Undervoltage sensor causes the device to switch off and reset.

[9] Overvoltage sensor causes the device to switch off to protect the load.

[10] See **Table 3 "Truth table"**

[11] $5.5\text{ V} \leq V_{BG} \leq 35\text{ V}$

[12] The battery-to-load threshold voltage for short circuit is approximately proportional to the battery supply voltage.

[13] After cooling below the reset temperature the switch will resume normal operation.

[14] The status output is an open drain transistor and requires an external pull-up circuit to indicate a logic HIGH.

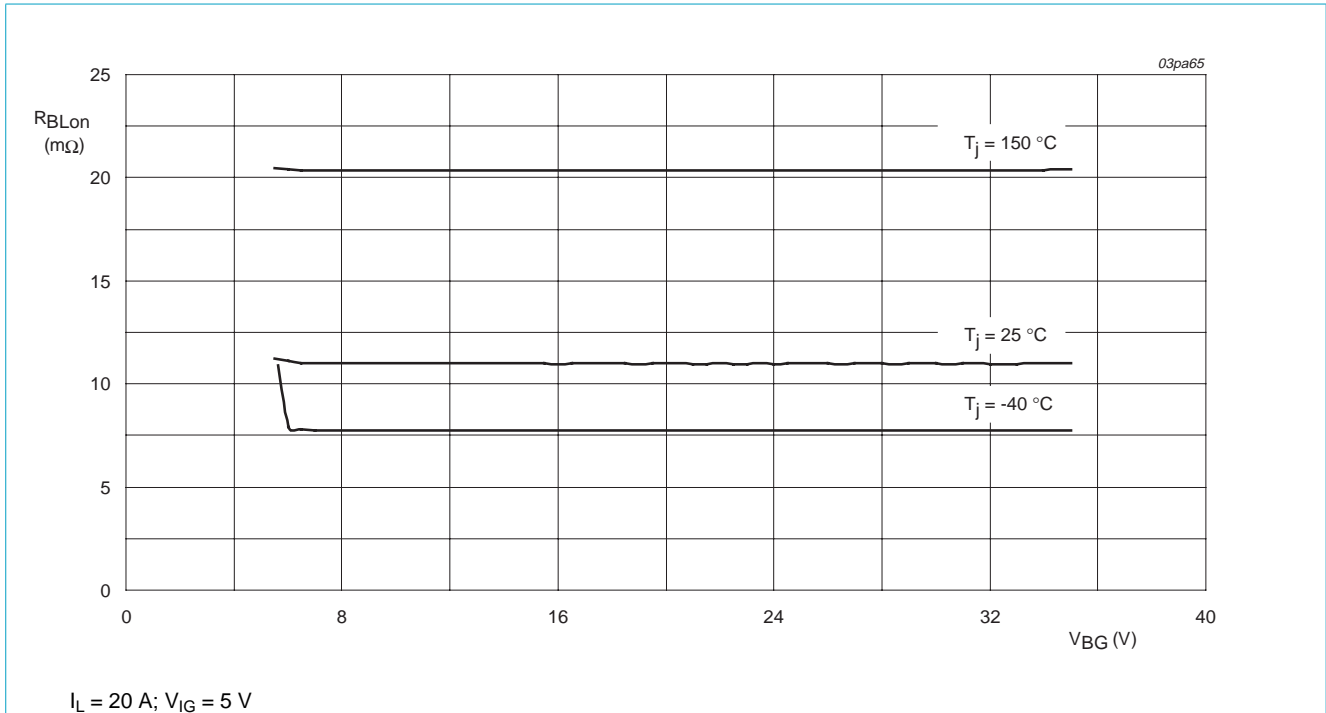

Fig 5. Battery-load on-state resistance as a function of battery-ground supply voltage; typical values.

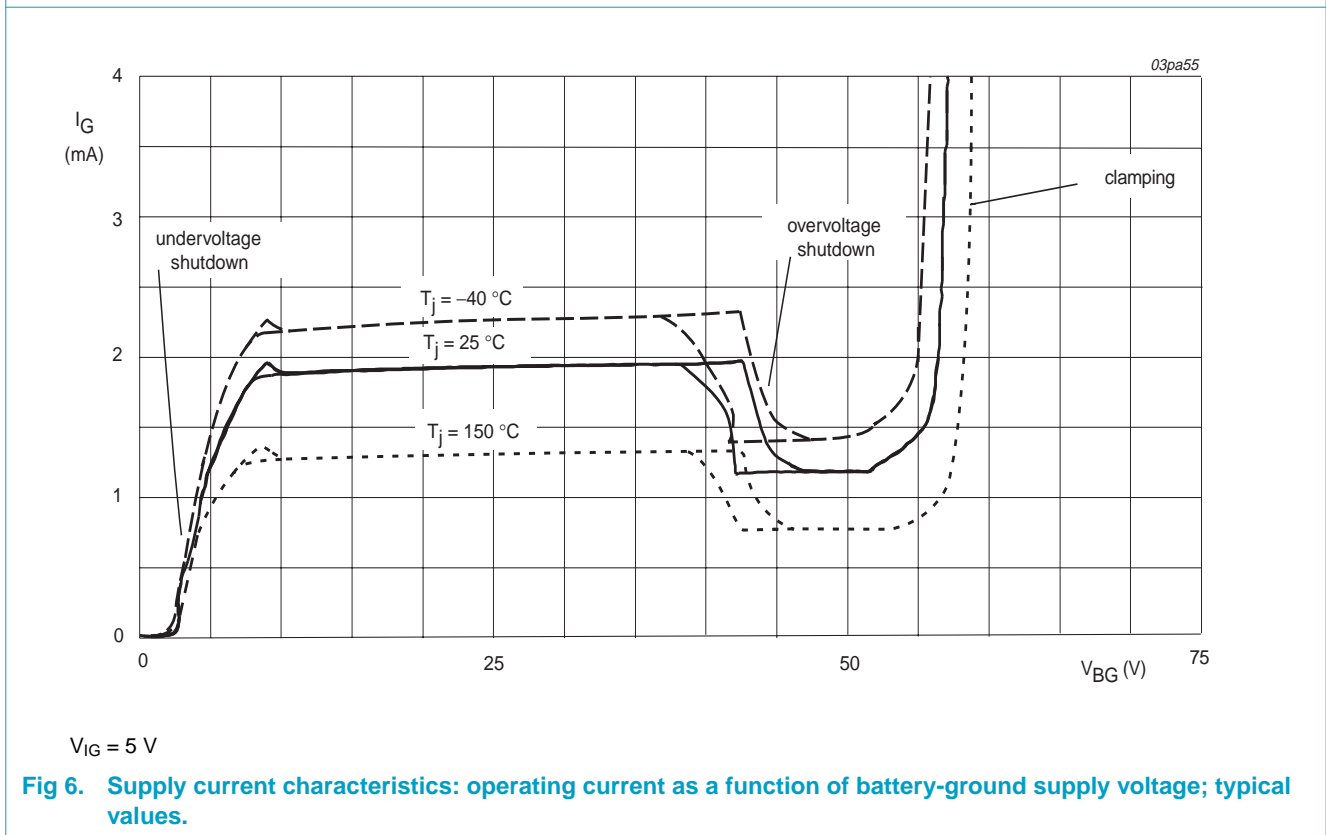
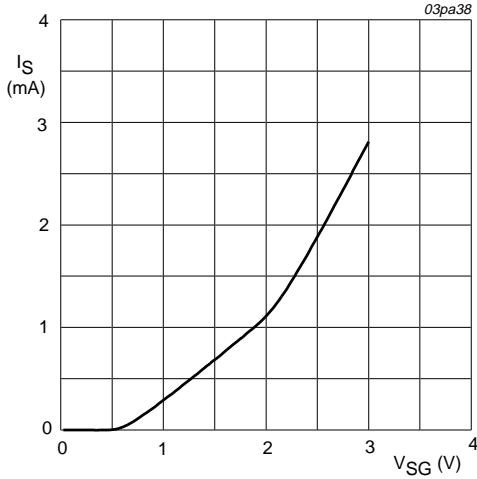
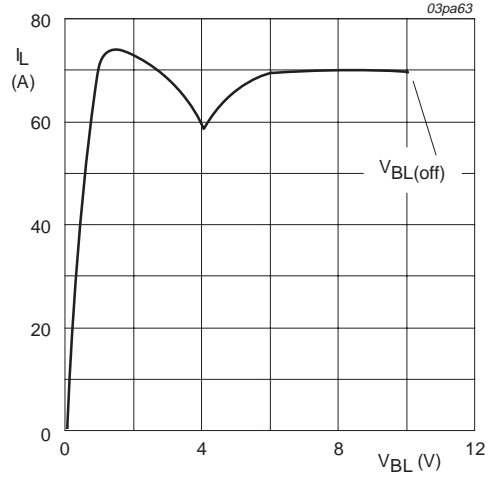

Fig 6. Supply current characteristics: operating current as a function of battery-ground supply voltage; typical values.



V_{BG} = 13 V; V_{IG} = 5 V; T_J = 25 °C

Fig 7. Status current as a function of status-ground voltage; typical values.



V_{BG} = 16 V; V_{IG} = 5 V; T_{mb} = 25 °C (the device trips after 200 μs (typical), and status goes LOW).

Fig 8. Load current limiting as a function of battery-load voltage; typical values.

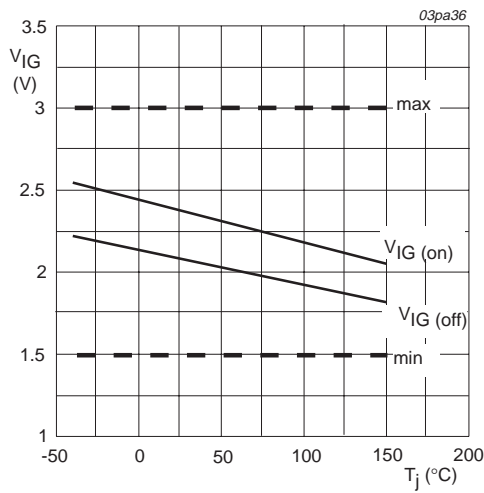

9 V ≤ V_{BG} ≤ 16 V

Fig 9. Input-ground voltage as a function of junction temperature.

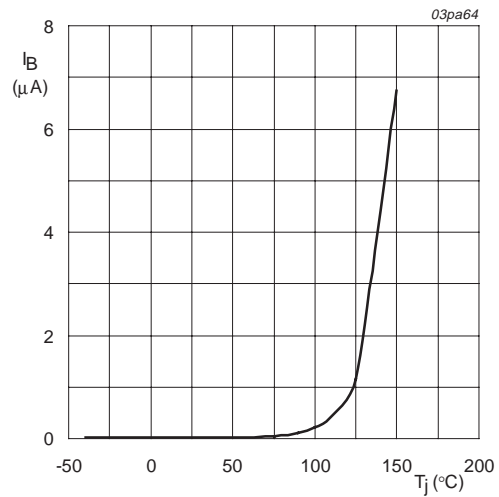

V_{BG} = 16 V

Fig 10. Battery quiescent current as a function of junction temperature; typical values.

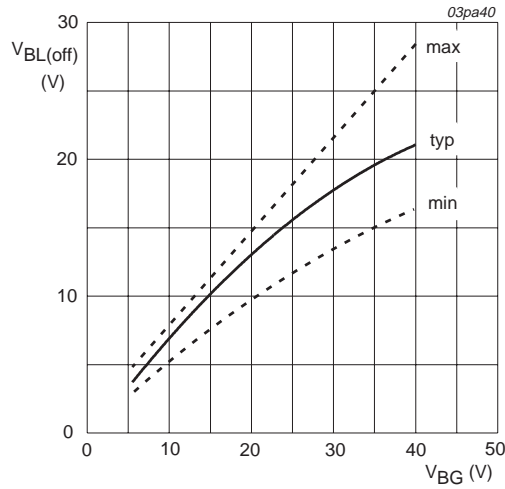

$V_{IG} = 5\text{ V}; -40\text{ }^{\circ}\text{C} \leq T_{mb} \leq +150\text{ }^{\circ}\text{C}$

Fig 11. Battery-load turn-off voltage as a function of battery-ground voltage.

8. Dynamic characteristics

Table 7: Switching characteristics

$T_{mb} = 25\text{ }^{\circ}\text{C}; V_{BG} = 13\text{ V};$ resistive load $R_L = 13\text{ }\Omega$. *Figure 13*

Symbol	Parameter	Conditions	Min	Typ	Max	Unit
Turn-on measured from the input going HIGH						
$t_{d(on)}$	turn-on delay time	to 10% V_L	-	40	90	μs
dV/dt_{on}	rising slew rate	30 to 70% V_L	-	0.5	1.0	$\text{V}/\mu\text{s}$
t_{on}	turn-on switching time	to 90% V_L	-	180	310	μs
Turn-off measured from the input going LOW						
$t_{d(off)}$	turn-off delay time	to 90% V_L	-	75	120	μs
dV/dt_{off}	falling slew rate	70 to 30% V_L	-	0.5	1.0	$\text{V}/\mu\text{s}$
t_{off}	turn-off switching time	to 10% V_L	-	105	160	μs

Table 8: Status response times

Limits are valid for $-40\text{ }^{\circ}\text{C} \leq T_{mb} \leq +150\text{ }^{\circ}\text{C}$ and typical values for $T_{mb} = 25\text{ }^{\circ}\text{C}$ unless otherwise specified.

Symbol	Parameter	Conditions	Min	Typ	Max	Unit
Measured from when the input goes HIGH						
$t_{d(sc)}$	short circuit response time	$V_{BL} > V_{BL(off)}$; <i>Figure 16</i>	-	180	250	μs
$t_{d(Ic)}$	low current detect response time	$I_L < I_{L(LC)}$; <i>Figure 15</i>	-	200	-	μs

Table 9: Capacitances

$T_{mb} = 25\text{ }^\circ\text{C}$; $f = 1\text{ MHz}$; $V_{IG} = 0\text{ V}$.

Symbol	Parameter	Conditions	Min	Typ	Max	Unit
C_{ig}	input-ground capacitance	$V_{BG} = 13\text{ V}$	-	15	20	pF
C_{bl}	battery-load output capacitance	$V_{BL} = 13\text{ V}$	-	635	900	pF
C_{sg}	status-ground capacitance	$V_{SG} = 5\text{ V}$	-	11	15	pF

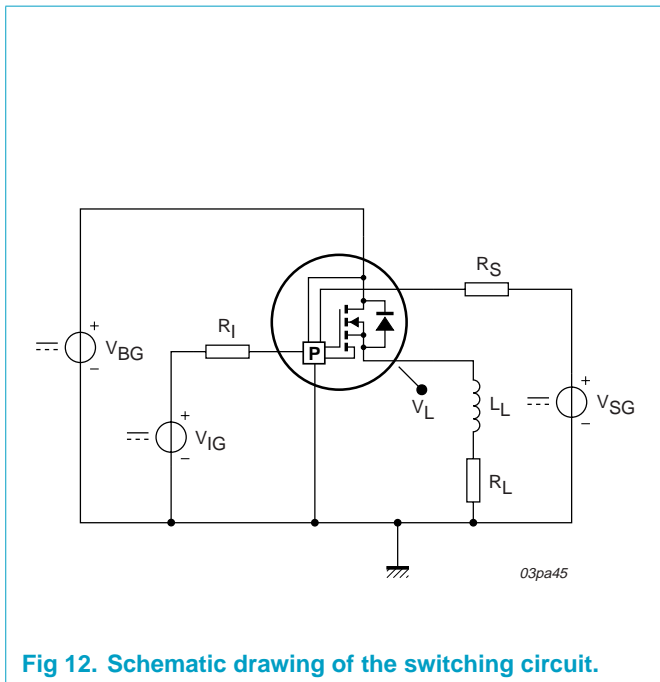

Fig 12. Schematic drawing of the switching circuit.

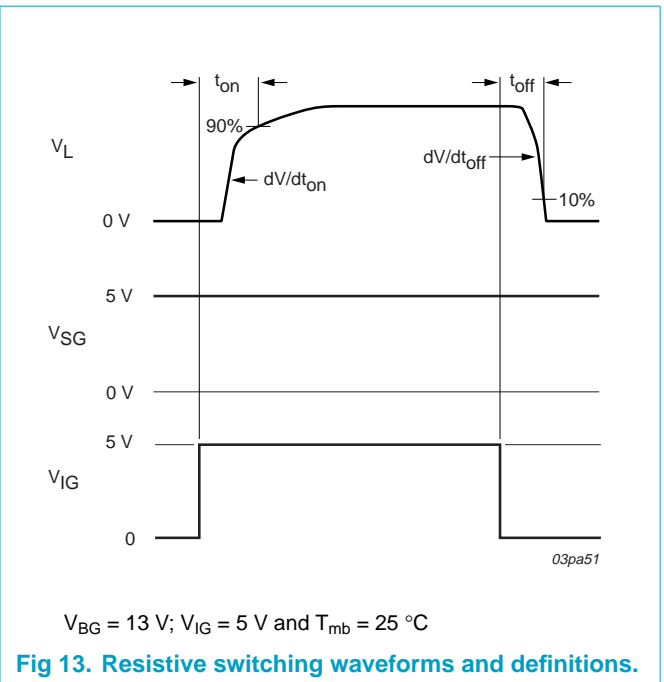

Fig 13. Resistive switching waveforms and definitions.

$V_{BG} = 13\text{ V}$; $V_{IG} = 5\text{ V}$ and $T_{mb} = 25\text{ }^\circ\text{C}$

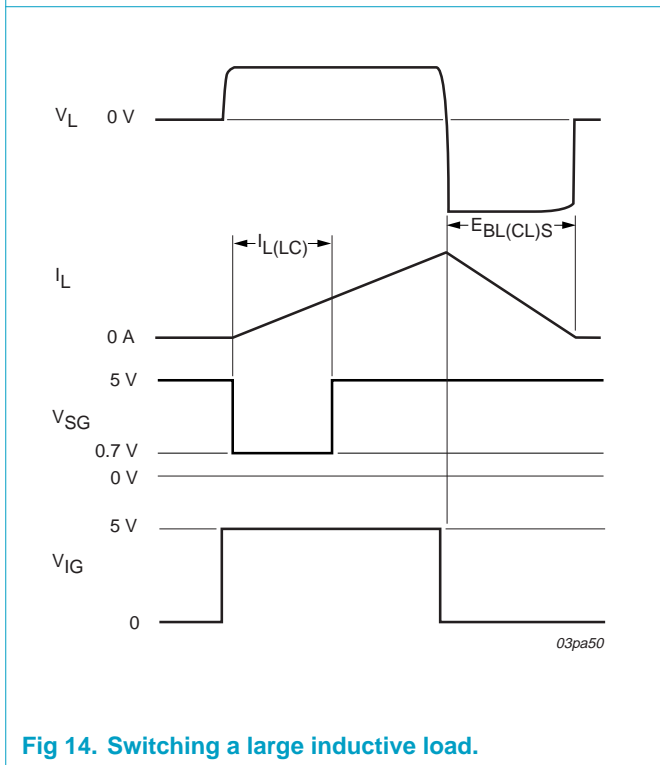

Fig 14. Switching a large inductive load.

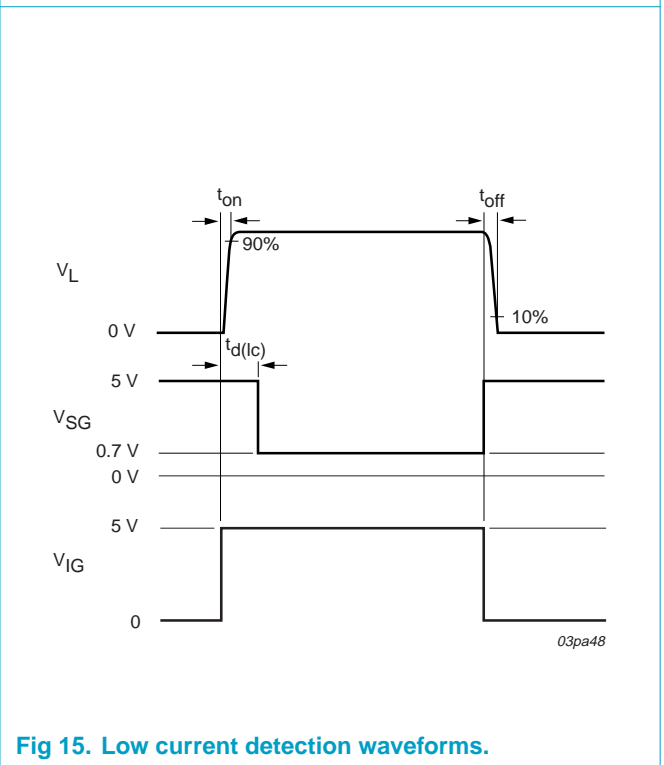
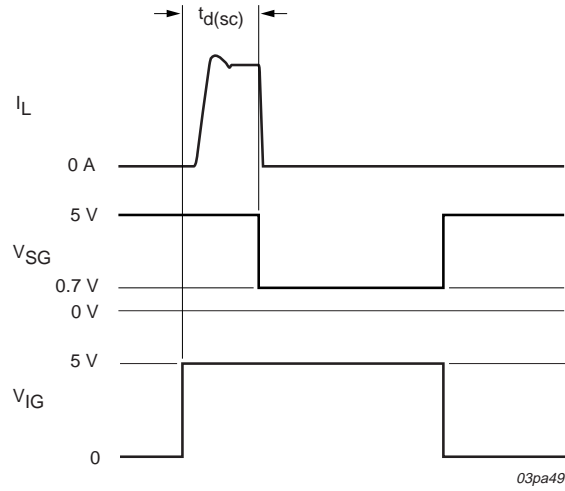

Fig 15. Low current detection waveforms.



$$V_{BL} \geq V_{BL(off)}$$

Fig 16. Short circuit protection waveforms.

9. Package outline

Plastic single-ended surface mounted package (Philips version of D²-PAK); 5 leads (one lead cropped)

SOT426

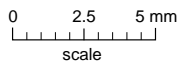
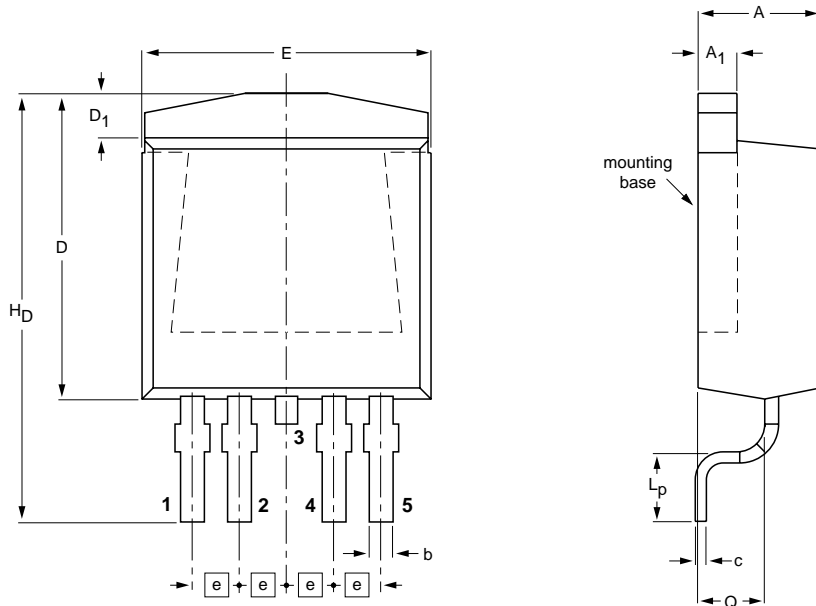

DIMENSIONS (mm are the original dimensions)

UNIT	A	A ₁	b	c	D max.	D ₁	E	e	L _p	H _D	Q
mm	4.50 4.10	1.40 1.27	0.85 0.60	0.64 0.46	11	1.60 1.20	10.30 9.70	1.70	2.90 2.10	15.80 14.80	2.60 2.20

OUTLINE VERSION	REFERENCES				EUROPEAN PROJECTION	ISSUE DATE
	IEC	JEDEC	EIAJ			
SOT426						-98-12-14 99-06-25

Epoxy meets UL94 V0 at 1/8". Net mass: 1.5g. For soldering guidelines and surface mount footprint design, please refer to Data Handbook SC18.

Fig 17. SOT426 (D²-PAK).

Plastic single-ended package; heatsink mounted; 1 mounting hole;
5-lead TO-220 lead form option

SOT263B-01

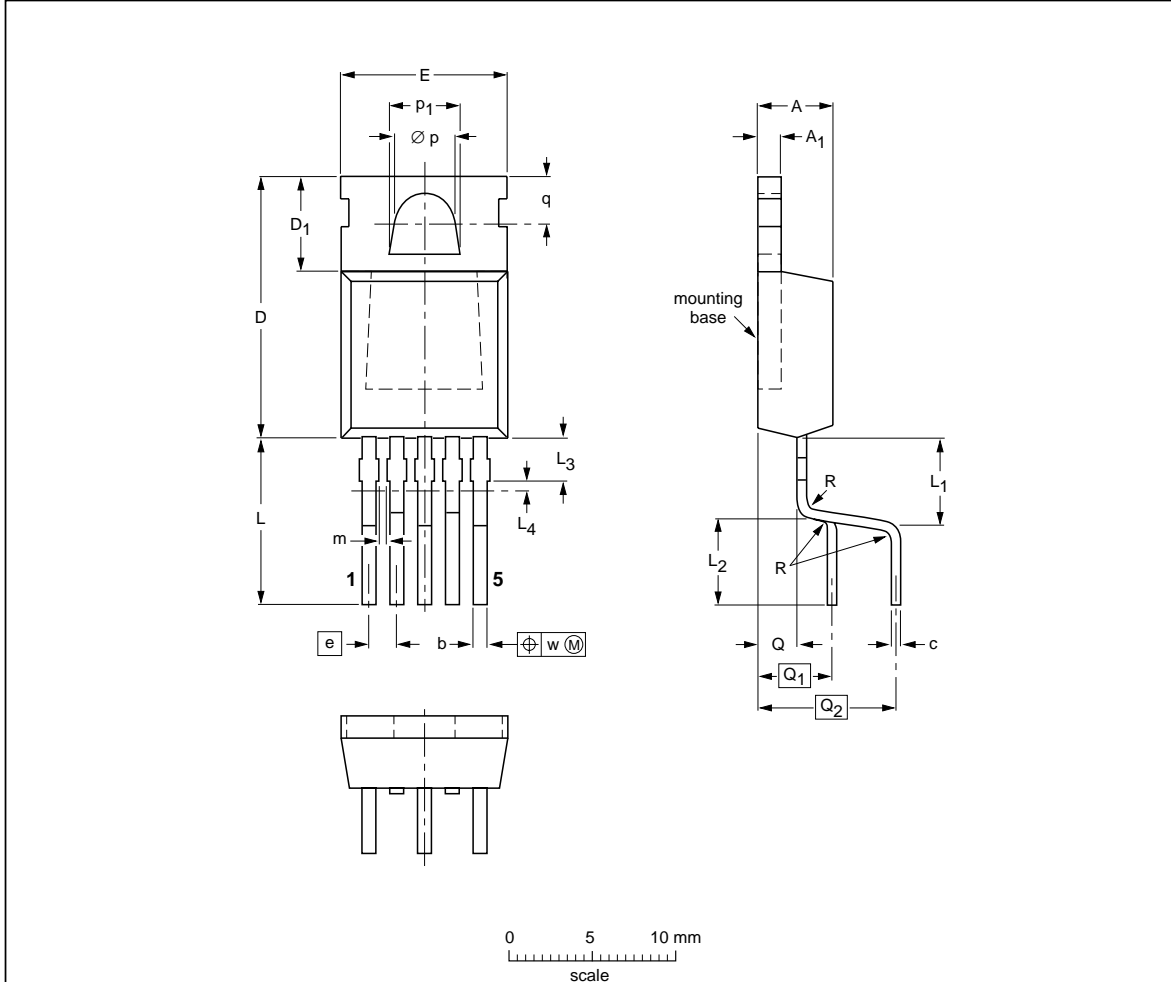

DIMENSIONS (mm are the original dimensions)

UNIT	A	A ₁	b	c	D	D ₁	E	e	L	L ₁	L ₂	L ₃ ⁽¹⁾	L ₄ ⁽²⁾ max.	m	∅ p	p ₁	q	Q	Q ₁	Q ₂	R	w
mm	4.5 4.1	1.39 1.27	0.85 0.70	0.7 0.4	15.8 15.2	6.4 5.9	10.3 9.7	1.7	9.8 9.7	5.9 5.3	5.2 5.0	2.4 1.6	0.5	0.8 0.6	3.8 3.6	4.3 4.1	3.0 2.7	2.0	4.5	8.2	0.5	0.4

Notes

- Terminal dimensions are uncontrolled in this zone.
- Positional accuracy of the terminals is controlled in this zone.

OUTLINE VERSION	REFERENCES			EUROPEAN PROJECTION	ISSUE DATE
	IEC	JEDEC	EIAJ		
SOT263B-01		5-lead (option) TO-220			01-01-11

Refer to mounting instructions for TO-220 packages. Epoxy meets UL94 VO at 1/8". Net mass: 2g

Fig 18. SOT263B-01.

10. Revision history

Table 10: Revision history

Rev	Date	CPCN	Description
01	20030317	-	Product data (9397 750 10768).

11. Data sheet status

Level	Data sheet status ^[1]	Product status ^{[2][3]}	Definition
I	Objective data	Development	This data sheet contains data from the objective specification for product development. Philips Semiconductors reserves the right to change the specification in any manner without notice.
II	Preliminary data	Qualification	This data sheet contains data from the preliminary specification. Supplementary data will be published at a later date. Philips Semiconductors reserves the right to change the specification without notice, in order to improve the design and supply the best possible product.
III	Product data	Production	This data sheet contains data from the product specification. Philips Semiconductors reserves the right to make changes at any time in order to improve the design, manufacturing and supply. Relevant changes will be communicated via a Customer Product/Process Change Notification (CPCN).

[1] Please consult the most recently issued data sheet before initiating or completing a design.

[2] The product status of the device(s) described in this data sheet may have changed since this data sheet was published. The latest information is available on the Internet at URL <http://www.semiconductors.philips.com>.

[3] For data sheets describing multiple type numbers, the highest-level product status determines the data sheet status.

12. Definitions

Short-form specification — The data in a short-form specification is extracted from a full data sheet with the same type number and title. For detailed information see the relevant data sheet or data handbook.

Limiting values definition — Limiting values given are in accordance with the Absolute Maximum Rating System (IEC 60134). Stress above one or more of the limiting values may cause permanent damage to the device. These are stress ratings only and operation of the device at these or at any other conditions above those given in the Characteristics sections of the specification is not implied. Exposure to limiting values for extended periods may affect device reliability.

Application information — Applications that are described herein for any of these products are for illustrative purposes only. Philips Semiconductors make no representation or warranty that such applications will be suitable for the specified use without further testing or modification.

13. Disclaimers

Life support — These products are not designed for use in life support appliances, devices, or systems where malfunction of these products can reasonably be expected to result in personal injury. Philips Semiconductors

customers using or selling these products for use in such applications do so at their own risk and agree to fully indemnify Philips Semiconductors for any damages resulting from such application.

Right to make changes — Philips Semiconductors reserves the right to make changes in the products - including circuits, standard cells, and/or software - described or contained herein in order to improve design and/or performance. When the product is in full production (status 'Production'), relevant changes will be communicated via a Customer Product/Process Change Notification (CPCN). Philips Semiconductors assumes no responsibility or liability for the use of any of these products, conveys no licence or title under any patent, copyright, or mask work right to these products, and makes no representations or warranties that these products are free from patent, copyright, or mask work right infringement, unless otherwise specified.

14. Trademarks

TOPFET — is a trademark of Koninklijke Philips Electronics N.V.

TrenchMOS — is a trademark of Koninklijke Philips Electronics N.V.

Contact information

For additional information, please visit <http://www.semiconductors.philips.com>.

For sales office addresses, send e-mail to: sales.addresses@www.semiconductors.philips.com.

Fax: +31 40 27 24825

Contents

1	Product profile	1
1.1	Description	1
1.2	Features	1
1.3	Applications	1
1.4	Quick reference data	1
2	Pinning information	2
2.1	Pin description	2
3	Block diagram	3
4	Functional description	3
5	Limiting values	4
6	Thermal characteristics	4
7	Static characteristics	5
8	Dynamic characteristics	9
9	Package outline	12
10	Revision history	14
11	Data sheet status	15
12	Definitions	15
13	Disclaimers	15
14	Trademarks	15

© Koninklijke Philips Electronics N.V. 2003.
Printed in The Netherlands

All rights are reserved. Reproduction in whole or in part is prohibited without the prior written consent of the copyright owner.

The information presented in this document does not form part of any quotation or contract, is believed to be accurate and reliable and may be changed without notice. No liability will be accepted by the publisher for any consequence of its use. Publication thereof does not convey nor imply any license under patent- or other industrial or intellectual property rights.

Date of release: 17 March 2003

Document order number: 9397 750 10768



PHILIPS

Let's make things better.