



SSL8001T

GreenChip SMPS low power control IC

Rev. 1 — 3 November 2014

Product data sheet

1. General description

The SSL8001T is a small low-cost Switched Mode Power Supply (SMPS) controller IC for low-power supplies in lamps (up to 12.5 W) where the power factor is important. It operates directly from the rectified universal mains input.

The device includes a low-voltage MOSFET switch for driving an external low-cost high-voltage MOSFET. It has been optimized for flyback converter topologies to provide a high power factor in combination a low power consumption in the no-load condition.

The SSL8001T provides a circuit for fast start-up directly from the rectified mains voltage without any external bleeder circuits.

The converter operates as a regulated voltage source from no-load up to the maximum output current. It also operates as a current source delivering the maximum current over a wide output voltage range. Using the SSL8001T, a low-power converter can be built at minimum cost and with the minimum number of external components.

The controller regulates the output voltage with primary-side sensing which eliminates the requirement for an additional secondary feedback circuitry and simplifies the design. At higher power levels, a frequency and current control mode is used. It operates with burst mode control at low power levels and in the no-load condition. The burst mode minimizes audible noise. It provides an energy save state which reduces the power consumption in no-load condition. The burst mode frequency of 1600 Hz enables low power consumption at high mains input.

2. Features and benefits

2.1 Power features

- Low-power SMPS controller designed for lamp applications up to 12.5 W
- Primary sensing for control of the output voltage without optocoupler and secondary feedback circuitry
- Minimizes audible noise in all operation modes
- Power factor up to 0.9 can be achieved
- Jitter function for reduced EMI
- Cable compensation to increase the output voltage when the load is applied
- Integrated low-voltage MOSFET switch to control external low-cost high-voltage MOSFET



2.2 Green features

- Low supply current in no-load condition with energy save mode
- Incorporates a high-voltage start-up circuit with zero current consumption under normal switching operation
- Available in halogen-free and Restriction of Hazardous Substances (RoHS) SO8 package

2.3 Protection features

- OverVoltage Protection (OVP) on feedback control pin (FB) with safe restart
- UnderVoltage LockOut (UVLO) on IC supply pin
- OverTemperature Protection (OTP)
- Soft-start by reduced peak current for zero and low output voltage
- Demagnetization protection for guaranteed discontinuous conduction mode operation
- Open and short-circuit protection of the Feedback control (FB) pin
- Short-circuit protection of the output

3. Applications

- LED lamps up to 12.5 W

4. Quick reference data

Table 1. Quick reference data

Symbol	Parameter	Conditions	Min	Typ	Max	Unit
Power switch (pin SWITCH)						
R _{on}	on-state resistance	low-voltage MOSFET switch; I _{ds} = 100 mA; T _j = 25 °C	0.75	0.85	1.0	Ω
Oscillator (pins SWITCH and SENSE)						
f _{burst}	burst mode frequency	burst frequency in CVB mode, without jitter	1350	1550	1750	Hz
f _{osc(high)}	high oscillator frequency	maximum switching frequency in CV and CC mode, without jitter	46	52	58	kHz
Supply (pin VCC)						
V _{CC(startup)}	start-up supply voltage		15	17	19	V
V _{CC(stop)}	stop supply voltage	undervoltage lockout of IC	7.5	8.5	9.5	V

5. Ordering information

Table 2. Ordering information

Type number	Package		Version
	Name	Description	
SSL8001T	SO8	plastic small outline package; 8 leads; body width 3.9 mm	SOT96-1

6. Block diagram

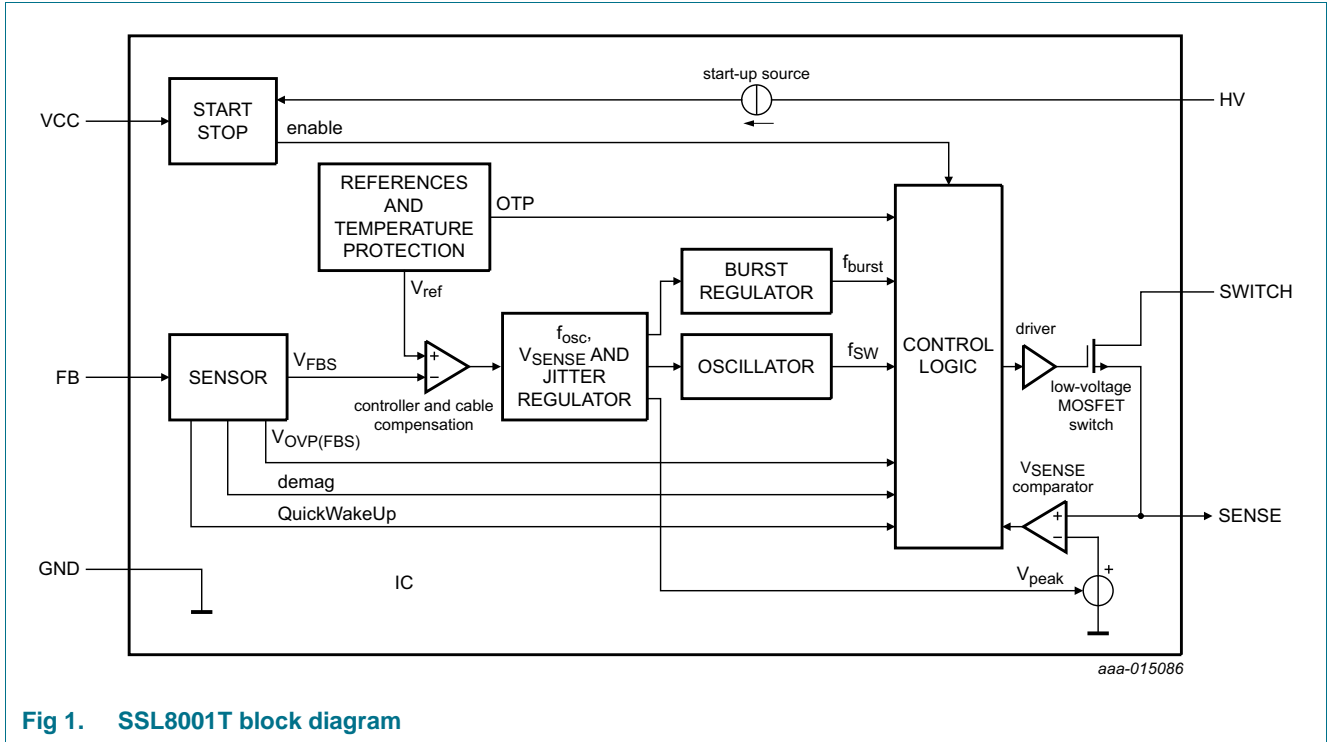

Fig 1. SSL8001T block diagram

7. Pinning information

7.1 Pinning

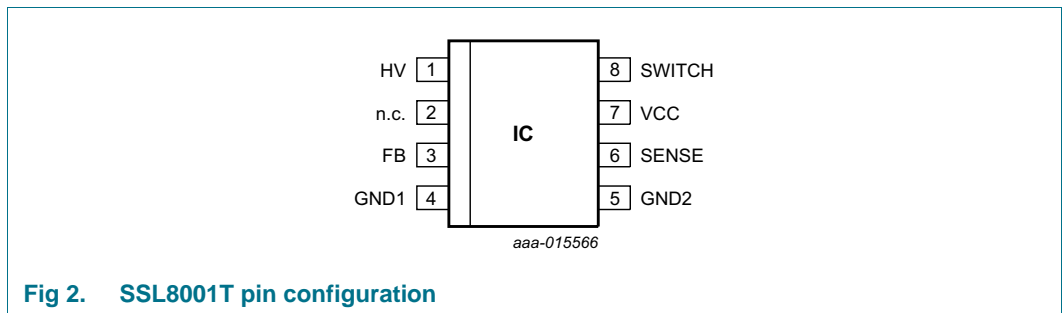

Fig 2. SSL8001T pin configuration

7.2 Pin description

Table 3. Pin description

Pin	Pin name	I/O type	Description
1	HV	I	high-voltage start-up
2	n.c.	-	not connected; high-voltage spacer
3	FB	I	feedback input for voltage sensing
4	GND1	-	ground
5	GND2	-	ground
6	SENSE	I	source low-voltage MOSFET switch and sense input
7	VCC	I	supply input
8	SWITCH	I	source connection of external high-voltage MOSFET

8. Functional description

8.1 Start-up

The SSL8001T starts up by charging the VCC capacitor until the $V_{CC(\text{startup})}$ level. The charging current flows from the HV pin via an internal start-up current source to the VCC pin.

Once the start-up level has been reached, the start-up current source is switched off. During the switching operation, the start-up current source remains current-less and has zero bleeder loss.

8.2 Primary sensing

The FB input senses the reflected secondary voltage on the primary side. The FB input has a sample and hold function that samples the FB voltage on the secondary stroke to control the output voltage.

The sampled V_{FBS} voltage is the input for the SSL8001T's control loop and defines the operating mode.

8.3 Operating modes

The SSL8001T operates in three modes, one of which is active at the time. The three modes in order of decreasing load impedance are:

- CVB: Constant Voltage with Burst mode
- CV: Constant Voltage mode
- CC: Constant Current mode

The converter acts as a voltage source in CVB and CV modes.

The converter acts as a current source in CC mode.

8.3.1 Constant Voltage with Burst mode (CVB)

At low power, the SSL8001T operates in Burst mode.

Burst mode operates with a $V_{\text{ref-peak}} = 120$ mV, a switching frequency of 23 kHz and burst duty cycle regulation by sensing the FB voltage.

The SSL8001T features an energy save function that puts the main part of the analog blocks in a sleep mode with low supply current in burst mode. The burst mode enables the energy save mode in the non-switching part of the burst. The IC switches to the nominal supply just before new burst starts.

Transition from burst mode to CV mode happens at 100 % burst duty cycle: a burst filled with 32 pulses. The 100 % pulse train is identical to the lowest power level of the CV mode. If the FB voltage drops below 2.4 V in burst mode, the SSL8001T changes directly from burst mode to CV mode.

8.3.2 Constant Voltage mode (CV)

At higher power levels, the SSL8001T operates in CV mode. The FB pin senses the output voltage and the control keeps the output voltage constant over the power range.

CV mode starts at 23 kHz switching frequency and peak current regulation at the $V_{\text{ref-peak}}$ minimum level of 120 mV.

With an increasing power output, the $V_{\text{ref-peak}}$ level and the switching frequency are also increased.

CV mode is exited when the maximum power level is reached. Maximum power occurs at peak current regulation at the $V_{\text{ref-peak}}$ maximum level of 575 mV and a maximum switching frequency of 52 kHz.

8.3.3 Constant Current mode (CC)

The CC mode starts at maximum power delivery and keeps the output current constant for decreasing output voltage.

CC mode is enabled when the converter is operating at the maximum switching frequency with the maximum primary peak current when the FB voltage drops to below the regulated level.

Regulation of the switching frequency from 52 kHz down to 23 kHz controls the CC mode operation.

8.4 Jitter

The SSL8001T features a jitter function for ElectroMagnetic Interference (EMI) reduction. The switching frequency is 7 % typical for the spread spectrum. The sweep frequency is a low frequency of approximately 220 Hz. To keep the output power constant, the V_{SENSE} level is jittered with the opposite polarity. The jitter is active in all operation modes except burst mode.

8.5 Cable compensation

The SSL8001T features a cable compensation function which stabilizes the output voltage at the end of the output cable during load. The reference voltage tracks the load, increasing from 2.5 V at no-load up to 2.65 V at full load. This increase results in an increase of the output voltage to compensate for the voltage drop caused by the power factor improvement circuitry.

8.6 Short pin SENSE protection

The SSL8001T has an integrated protection against faults caused by a shorted SENSE pin or a shorted sense resistor. During every primary stroke, the voltage on the SENSE pin is monitored. In normal situations, the voltage on the SENSE pin reaches the sense protection trigger level after the sense protection time has passed. When the SENSE voltage does not reach this level, the SENSE pin is shorted and the protection is activated. The IC stops switching and restarts. The value of the sense protection time is automatically adapted to the mains input voltage.

8.7 Hiccup mode protection

The hiccup mode protects the power supply from damage in case of current overload situations. The output voltage is sensed via the FB pin. If the voltage on the FB pin drops below the $V_{th(hiccup)}$ level for a time exceeding $t_{blank(hiccup)}$, the SSL8001T stops switching and restarts. As long as the fault condition is present, the IC makes repetitive restart attempts. Once the fault condition is removed, normal operation is resumed.

8.8 OverTemperature Protection (OTP)

The IC incorporates an accurate internal temperature protection. When the junction temperature exceeds the overtemperature protection threshold temperature, the IC stops switching. Once the temperature has dropped with the overtemperature protection temperature hysteresis ($T < T_{pl(IC)} - T_{pl(IC)hys}$), the IC restarts.

9. Limiting values

Table 4. Limiting values

In accordance with the Absolute Maximum Rating System (IEC 60134).

Symbol	Parameter	Conditions	Min	Max	Unit
General					
T _{amb}	ambient temperature		-40	+125	°C
T _j	junction temperature		-40	+150	°C
T _{stg}	storage temperature		-55	+150	°C
V _{ESD}	electrostatic discharge voltage	CDM; all pins	-500	+500	V
		HBM; all pins [1]	-2000	+2000	V
Voltages					
V _{HV}	voltage on pin HV		-0.3	+550	V
V _{SENSE}	voltage on pin SENSE		-0.3	+5	V
V _{CC}	supply voltage		-0.3	+40	V
V _{SWITCH}	voltage on pin SWITCH		-0.3	+40	V
V _{FB}	voltage on pin FB		-20	+5	V
Currents					
I _{SWITCH}	current on pin SWITCH		-1.1	1.1	A
I _{SENSE}	current on pin SENSE		-1.1	1.1	A

[1] Human body model: equivalent to discharging a 100 pF capacitor through a 1.5 kΩ series resistor.

10. Thermal characteristics

Table 5. Thermal characteristics

Symbol	Parameter	Conditions	Typ	Unit
R _{th(j-a)}	thermal resistance from junction to ambient	in free air; JEDEC test board	150	K/W
		in free air; on open PCB of 2.2 cm × 2.6 cm; 2-layer; 35 μm Copper	200	K/W

11. Characteristics

Table 6. Characteristics

$V_{CC} = 20\text{ V}$; $FB = 0\text{ V}$; $R_{source} = 0.75\ \Omega$; $T_j = 25\text{ }^\circ\text{C}$; all voltages referenced to GND; positive currents flow into the IC, unless otherwise specified.

Symbol	Parameter	Conditions	Min	Typ	Max	Unit
Supply (pin VCC)						
$I_{CC(\text{startup})}$	start-up supply current	$V_{CC} = 0\text{ V}$	-1.5	-1.2	-0.9	mA
$I_{CC(\text{startup})}$	start-up supply current	$V_{CC} = V_{CC(\text{startup})} - 1$	-1.3	-1.0	-0.7	mA
I_{CC}	supply current	$V_{FB} = 2.8\text{ V}$; non-switching; in energy save	130	170	210	μA
		CC mode	0.6	0.8	1.0	mA
$V_{CC(\text{startup})}$	start-up supply voltage		15	17	19	V
$V_{CC(\text{stop})}$	stop supply voltage	undervoltage lockout of IC	7.5	8.5	9.5	V
$T_{pl(\text{IC})}$	IC protection level temperature		140	150	160	$^\circ\text{C}$
$T_{pl(\text{IC})\text{hys}}$	hysteresis of IC protection level temperature		-	50	-	$^\circ\text{C}$
Feedback (pin FB)						
$V_{th(\text{ovp})\text{FB}}$	overvoltage protection threshold voltage on pin FB		3.1	3.2	3.3	V
$V_{ref(\text{FB})}$	reference voltage on pin FB	CV mode	2.45	2.5	2.55	V
$V_{th(\text{FB})}$	threshold voltage on pin FB	transition from burst mode to constant voltage	2.35	2.4	2.45	V
$V_{det(\text{demag})\text{FB}}$	demagnetization detection voltage on FB pin		25	50	75	mV
$t_{d(s)}$	sampling delay time	moment of sampling V_{FB} after start of secondary stroke; $V_{FB} = 2.35\text{ V}$	4.4	5.4	6.4	μs
Oscillator (pins SWICH and SENSE)						
f_{burst}	burst mode frequency	burst frequency in CVB mode, without jitter	1275	1575	1875	Hz
f_{jit}/f_{sw}	jitter frequency to switching frequency ratio	in all operation modes except in CVB mode	5	7	9	%
$f_{osc(\text{high})}$	high oscillator frequency	maximum switching frequency in CV and CC mode, without jitter	46	52	58	kHz
$f_{osc(\text{low})}$	low oscillator frequency	minimum switching frequency in CV and CC mode, without jitter. switching frequency in CVB mode	20	23	26	kHz
f_{mod}	modulation frequency	in current source operation	170	220	270	Hz
δ_{max}	maximum duty cycle		72	75	78	%
HV start-up (pin HV)						
$I_{off(\text{HV})}$	off-state current on pin HV	$V_{HV} = 325\text{ V}$	-	1	-	μA
Low-voltage MOSFET switch (pin SWITCH)						
R_{on}	on-state resistance	$I_{ds} = 100\text{ mA}$	0.75	0.85	1.0	Ω

Table 6. Characteristics ...continued

$V_{CC} = 20\text{ V}$; $FB = 0\text{ V}$; $R_{source} = 0.75\ \Omega$; $T_j = 25\text{ }^\circ\text{C}$; all voltages referenced to GND; positive currents flow into the IC, unless otherwise specified.

Symbol	Parameter	Conditions	Min	Typ	Max	Unit
Peak current comparator (pin SENSE)						
t_{PD}	propagation delay	$dV/dt = 0.2\text{ V}/\mu\text{s}$	-	100	-	ns
t_{leb}	leading edge blanking time		270	320	370	ns
$V_{sense(high)}$	high sense voltage	maximum peak voltage in CV and CC modes, without jitter; $V_{FB} = -10\text{ V}$	540	575	610	mV
$V_{sense(low)}$	low sense voltage	CVB mode; $V_{FB} = -10\text{ V}$	100	120	140	mV
$V_{sense}^2 f_{osc}$	square sense voltage times oscillator frequency	$V_{sense(high)}^2 * f_{osc(high)}$; in CV and CC modes, without jitter; $V_{FB} = -10\text{ V}$	15.8	17.0	18.2	V^2kHz
Sense pin short protection (pin SENSE)						
$V_{scp(high)}$	high short-circuit protection voltage		-	125	-	mV
$V_{scp(low)SENSE}$	low short-circuit protection voltage on pin SENSE		-	105	-	mV
$t_{blank(sc)SENSE}$	short-circuit protection blanking time on pin SENSE	$V_{FB} = -10\text{ V}$	1	1.35	1.7	μs
Hiccup protection (pin FB)						
$V_{th(hiccup)}$	hiccup threshold voltage		1.35	1.45	1.55	V
$V_{th(rel)(hiccup)}$	hiccup release threshold voltage		1.6	1.7	1.8	V
$t_{blank(hiccup)}$	hiccup blanking time	at minimum switching frequency	15	21	27	ms

12. Application information

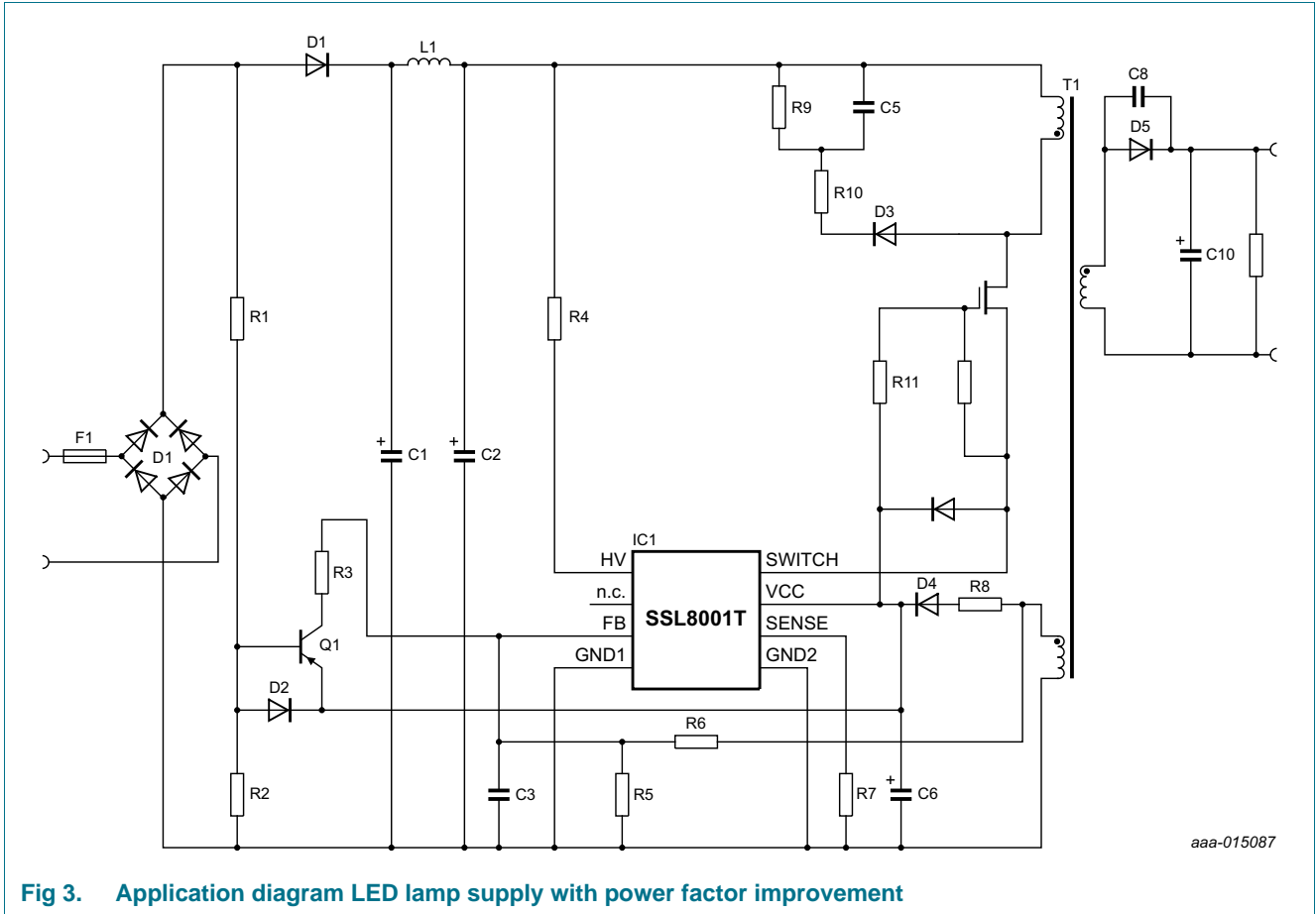

aaa-015087

Fig 3. Application diagram LED lamp supply with power factor improvement

13. Package outline

SO8: plastic small outline package; 8 leads; body width 3.9 mm

SOT96-1

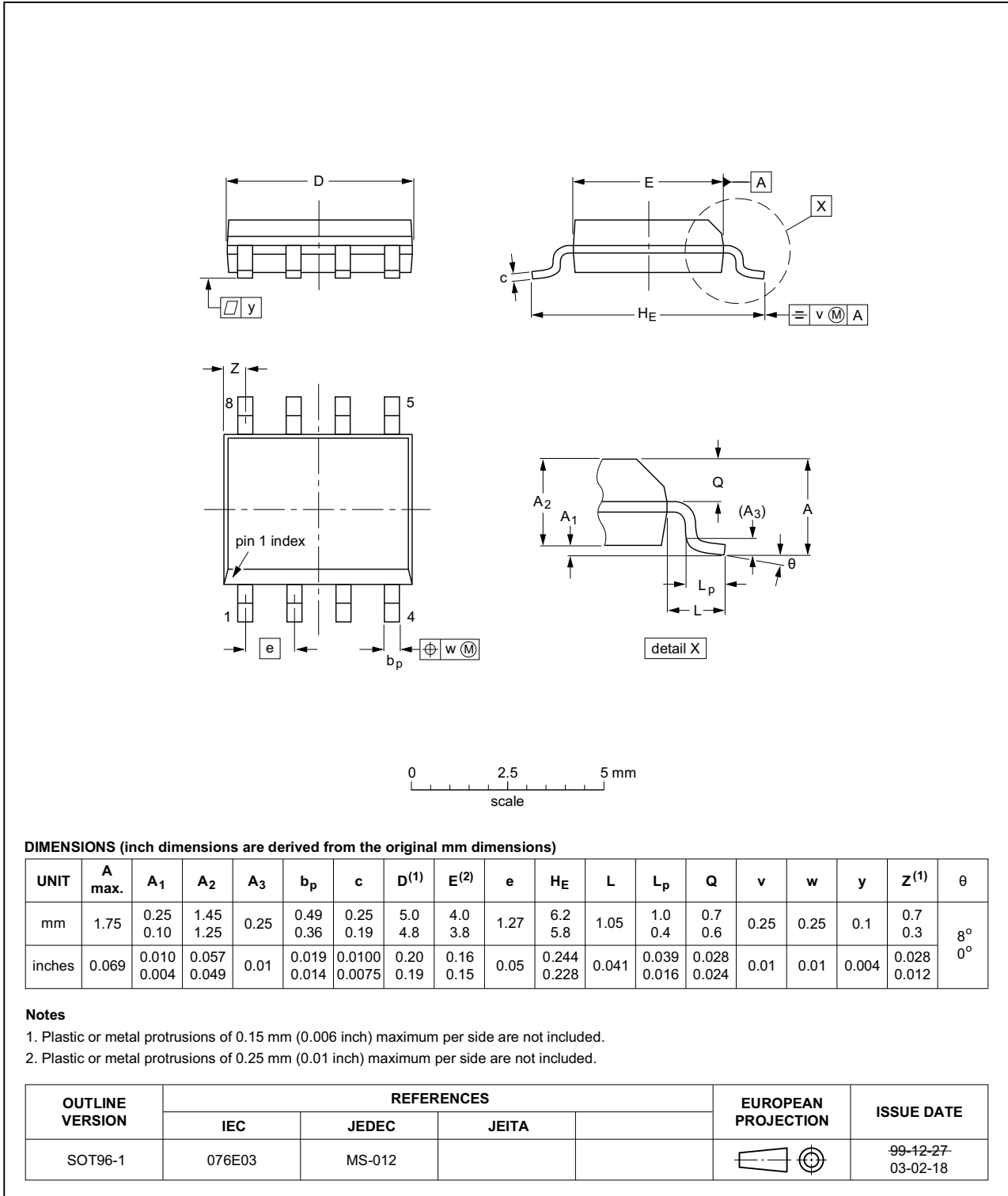

Fig 4. Package outline SOT96-1 (SO8)

14. Revision history

Table 7. Revision history

Document ID	Release date	Data sheet status	Change notice	Supersedes
SSL8001T v.1	20141103	Product data sheet	-	-

15. Legal information

15.1 Data sheet status

Document status ^{[1][2]}	Product status ^[3]	Definition
Objective [short] data sheet	Development	This document contains data from the objective specification for product development.
Preliminary [short] data sheet	Qualification	This document contains data from the preliminary specification.
Product [short] data sheet	Production	This document contains the product specification.

[1] Please consult the most recently issued document before initiating or completing a design.

[2] The term 'short data sheet' is explained in section "Definitions".

[3] The product status of device(s) described in this document may have changed since this document was published and may differ in case of multiple devices. The latest product status information is available on the Internet at URL <http://www.nxp.com>.

15.2 Definitions

Draft — The document is a draft version only. The content is still under internal review and subject to formal approval, which may result in modifications or additions. NXP Semiconductors does not give any representations or warranties as to the accuracy or completeness of information included herein and shall have no liability for the consequences of use of such information.

Short data sheet — A short data sheet is an extract from a full data sheet with the same product type number(s) and title. A short data sheet is intended for quick reference only and should not be relied upon to contain detailed and full information. For detailed and full information see the relevant full data sheet, which is available on request via the local NXP Semiconductors sales office. In case of any inconsistency or conflict with the short data sheet, the full data sheet shall prevail.

Product specification — The information and data provided in a Product data sheet shall define the specification of the product as agreed between NXP Semiconductors and its customer, unless NXP Semiconductors and customer have explicitly agreed otherwise in writing. In no event however, shall an agreement be valid in which the NXP Semiconductors product is deemed to offer functions and qualities beyond those described in the Product data sheet.

15.3 Disclaimers

Limited warranty and liability — Information in this document is believed to be accurate and reliable. However, NXP Semiconductors does not give any representations or warranties, expressed or implied, as to the accuracy or completeness of such information and shall have no liability for the consequences of use of such information. NXP Semiconductors takes no responsibility for the content in this document if provided by an information source outside of NXP Semiconductors.

In no event shall NXP Semiconductors be liable for any indirect, incidental, punitive, special or consequential damages (including - without limitation - lost profits, lost savings, business interruption, costs related to the removal or replacement of any products or rework charges) whether or not such damages are based on tort (including negligence), warranty, breach of contract or any other legal theory.

Notwithstanding any damages that customer might incur for any reason whatsoever, NXP Semiconductors' aggregate and cumulative liability towards customer for the products described herein shall be limited in accordance with the *Terms and conditions of commercial sale* of NXP Semiconductors.

Right to make changes — NXP Semiconductors reserves the right to make changes to information published in this document, including without limitation specifications and product descriptions, at any time and without notice. This document supersedes and replaces all information supplied prior to the publication hereof.

Suitability for use — NXP Semiconductors products are not designed, authorized or warranted to be suitable for use in life support, life-critical or safety-critical systems or equipment, nor in applications where failure or malfunction of an NXP Semiconductors product can reasonably be expected to result in personal injury, death or severe property or environmental damage. NXP Semiconductors and its suppliers accept no liability for inclusion and/or use of NXP Semiconductors products in such equipment or applications and therefore such inclusion and/or use is at the customer's own risk.

Applications — Applications that are described herein for any of these products are for illustrative purposes only. NXP Semiconductors makes no representation or warranty that such applications will be suitable for the specified use without further testing or modification.

Customers are responsible for the design and operation of their applications and products using NXP Semiconductors products, and NXP Semiconductors accepts no liability for any assistance with applications or customer product design. It is customer's sole responsibility to determine whether the NXP Semiconductors product is suitable and fit for the customer's applications and products planned, as well as for the planned application and use of customer's third party customer(s). Customers should provide appropriate design and operating safeguards to minimize the risks associated with their applications and products.

NXP Semiconductors does not accept any liability related to any default, damage, costs or problem which is based on any weakness or default in the customer's applications or products, or the application or use by customer's third party customer(s). Customer is responsible for doing all necessary testing for the customer's applications and products using NXP Semiconductors products in order to avoid a default of the applications and the products or of the application or use by customer's third party customer(s). NXP does not accept any liability in this respect.

Limiting values — Stress above one or more limiting values (as defined in the Absolute Maximum Ratings System of IEC 60134) will cause permanent damage to the device. Limiting values are stress ratings only and (proper) operation of the device at these or any other conditions above those given in the Recommended operating conditions section (if present) or the Characteristics sections of this document is not warranted. Constant or repeated exposure to limiting values will permanently and irreversibly affect the quality and reliability of the device.

Terms and conditions of commercial sale — NXP Semiconductors products are sold subject to the general terms and conditions of commercial sale, as published at <http://www.nxp.com/profile/terms>, unless otherwise agreed in a valid written individual agreement. In case an individual agreement is concluded only the terms and conditions of the respective agreement shall apply. NXP Semiconductors hereby expressly objects to applying the customer's general terms and conditions with regard to the purchase of NXP Semiconductors products by customer.

No offer to sell or license — Nothing in this document may be interpreted or construed as an offer to sell products that is open for acceptance or the grant, conveyance or implication of any license under any copyrights, patents or other industrial or intellectual property rights.

Export control — This document as well as the item(s) described herein may be subject to export control regulations. Export might require a prior authorization from competent authorities.

Quick reference data — The Quick reference data is an extract of the product data given in the Limiting values and Characteristics sections of this document, and as such is not complete, exhaustive or legally binding.

Non-automotive qualified products — Unless this data sheet expressly states that this specific NXP Semiconductors product is automotive qualified, the product is not suitable for automotive use. It is neither qualified nor tested in accordance with automotive testing or application requirements. NXP Semiconductors accepts no liability for inclusion and/or use of non-automotive qualified products in automotive equipment or applications.

In the event that customer uses the product for design-in and use in automotive applications to automotive specifications and standards, customer (a) shall use the product without NXP Semiconductors' warranty of the product for such automotive applications, use and specifications, and (b)

whenever customer uses the product for automotive applications beyond NXP Semiconductors' specifications such use shall be solely at customer's own risk, and (c) customer fully indemnifies NXP Semiconductors for any liability, damages or failed product claims resulting from customer design and use of the product for automotive applications beyond NXP Semiconductors' standard warranty and NXP Semiconductors' product specifications.

Translations — A non-English (translated) version of a document is for reference only. The English version shall prevail in case of any discrepancy between the translated and English versions.

15.4 Trademarks

Notice: All referenced brands, product names, service names and trademarks are the property of their respective owners.

GreenChip — is a trademark of NXP Semiconductors N.V.

16. Contact information

For more information, please visit: <http://www.nxp.com>

For sales office addresses, please send an email to: salesaddresses@nxp.com

17. Contents

1	General description	1
2	Features and benefits	1
2.1	Power features	1
2.2	Green features	2
2.3	Protection features	2
3	Applications	2
4	Quick reference data	2
5	Ordering information	2
6	Block diagram	3
7	Pinning information	3
7.1	Pinning	3
7.2	Pin description	4
8	Functional description	4
8.1	Start-up	4
8.2	Primary sensing	4
8.3	Operating modes	4
8.3.1	Constant Voltage with Burst mode (CVB)	5
8.3.2	Constant Voltage mode (CV)	5
8.3.3	Constant Current mode (CC)	5
8.4	Jitter	5
8.5	Cable compensation	6
8.6	Short pin SENSE protection	6
8.7	Hiccup mode protection	6
8.8	OverTemperature Protection (OTP)	6
9	Limiting values	7
10	Thermal characteristics	7
11	Characteristics	8
12	Application information	10
13	Package outline	11
14	Revision history	12
15	Legal information	13
15.1	Data sheet status	13
15.2	Definitions	13
15.3	Disclaimers	13
15.4	Trademarks	14
16	Contact information	14
17	Contents	15

Please be aware that important notices concerning this document and the product(s) described herein, have been included in section 'Legal information'.

© NXP Semiconductors N.V. 2014. All rights reserved.

For more information, please visit: <http://www.nxp.com>
 For sales office addresses, please send an email to: salesaddresses@nxp.com

Date of release: 3 November 2014
 Document identifier: SSL8001T