

AN11231

KNX evaluation board using LPC1227 and NCN5120

Rev. 1 — 1 July 2012

Application note

Document information

Info	Content
Keywords	KNX, LPC1227, On Semiconductor NCN5120, Weinzierl Engineering GmbH, Building Automation, Sensors, HVAC, Lighting, ARM Cortex M0, Twisted pair TP1
Abstract	This application note describes the OM13042 KNX evaluation board that uses the LPC1227 Cortex M0 microcontroller and the NCN5120 KNX TP1 physical layer transceiver from On Semiconductor.



Revision history

Rev	Date	Description
1	20120701	Initial version

Contact information

For more information, please visit: <http://www.nxp.com>

For sales office addresses, please send an email to: salesaddresses@nxp.com

1. Document purpose

The purpose of this document is to describe the OM13042 KNX evaluation board design.

This document is intended for technical persons such as system architects, hardware and software engineers interested in designing and developing a KNX device using an NXP microcontroller.

2. Introduction

The KNX evaluation board is an example implementation for KNX devices using an NXP Cortex M0 microcontroller LPC1227, the KNX twisted pair transceiver NCN1520 from On Semiconductor and a KNX System B software stack from Weinzierl Engineering GmbH.

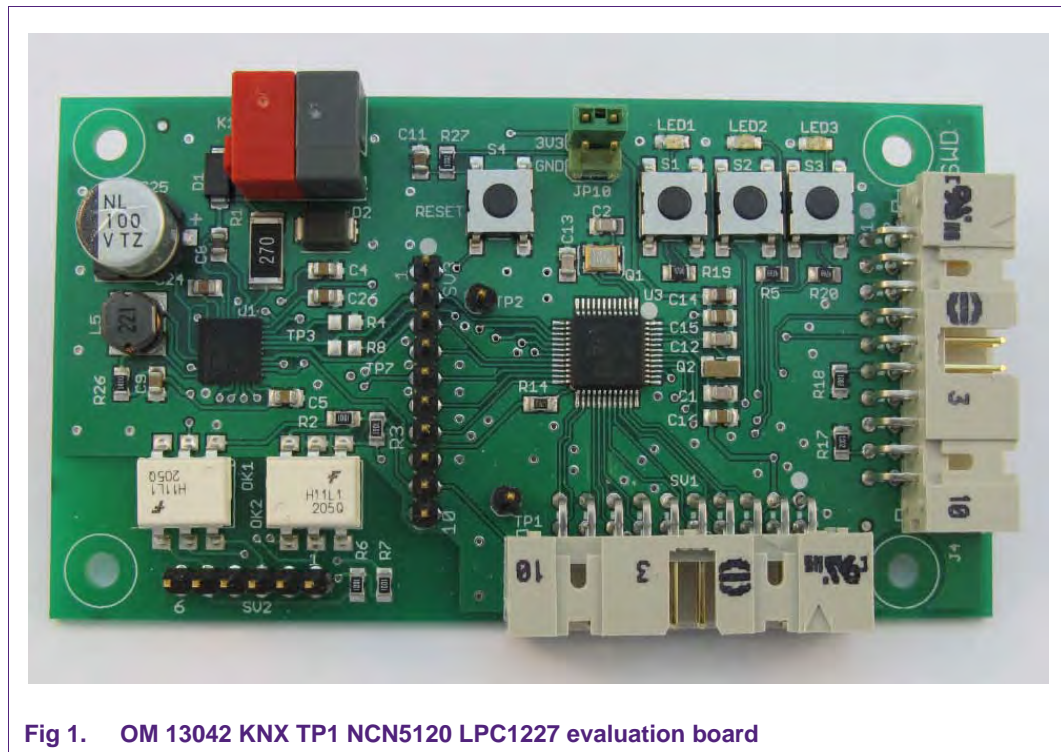

Fig 1. OM 13042 KNX TP1 NCN5120 LPC1227 evaluation board

The board supports the connection of actuators, sensors, switches or other applications in a building automation network. The evaluation board is available under the full name OM13042,598 and order code 935298293598.

3. Hardware

This chapter provides an overview of the board, its partitioning and all other hardware related information of the evaluation board.

3.1 Overview

An overview of the main components of the evaluation board is given in [Fig 2](#). The transceiver IC NCN5120 connects via UART to the LPC1227 microcontroller. Furthermore the transceiver creates a regulated 3.3 V power supply for the microcontroller from the unregulated bus supply. The LPC1227 creates a clock signal for

the digital control part of the transceiver. Several buttons and LEDs are available as sensor and actuator inputs to the system.

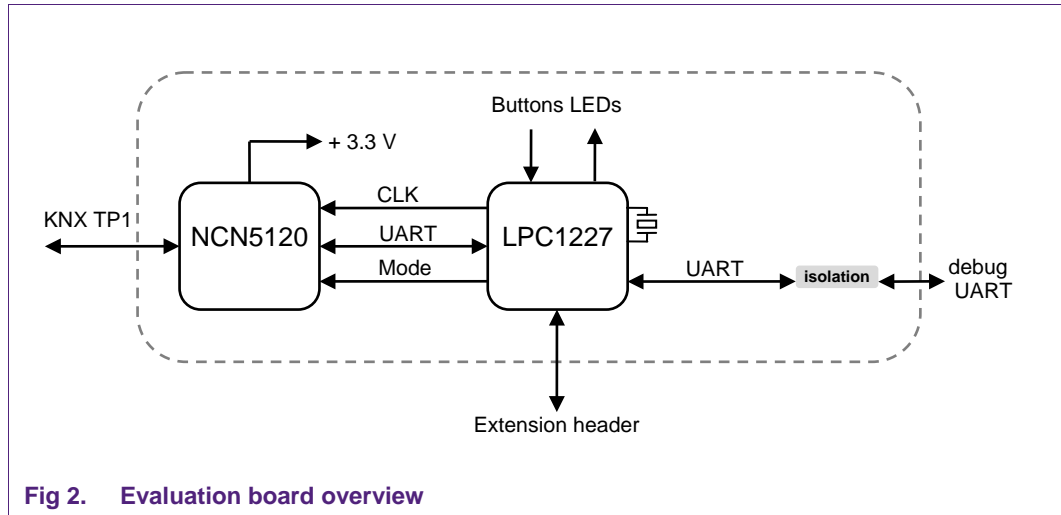

Fig 2. Evaluation board overview

3.2 PCB overview

The evaluation board is a two layer board with all components on the top side of the board. The component placement is given in Fig 5.

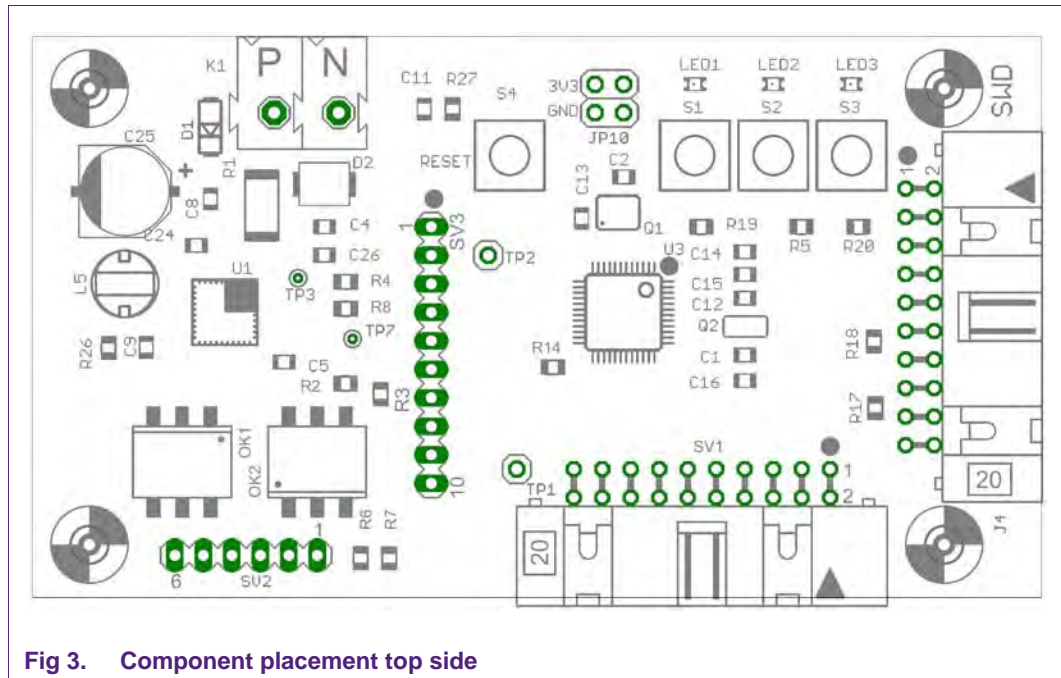

Fig 3. Component placement top side

The upper left part of the board contains the KNX TP1 header K1 to connect the KNX bus. Below the KNX connector, the board contains the physical transceiver part of the design. On the left bottom side the isolated UART interface is available on header SV2.

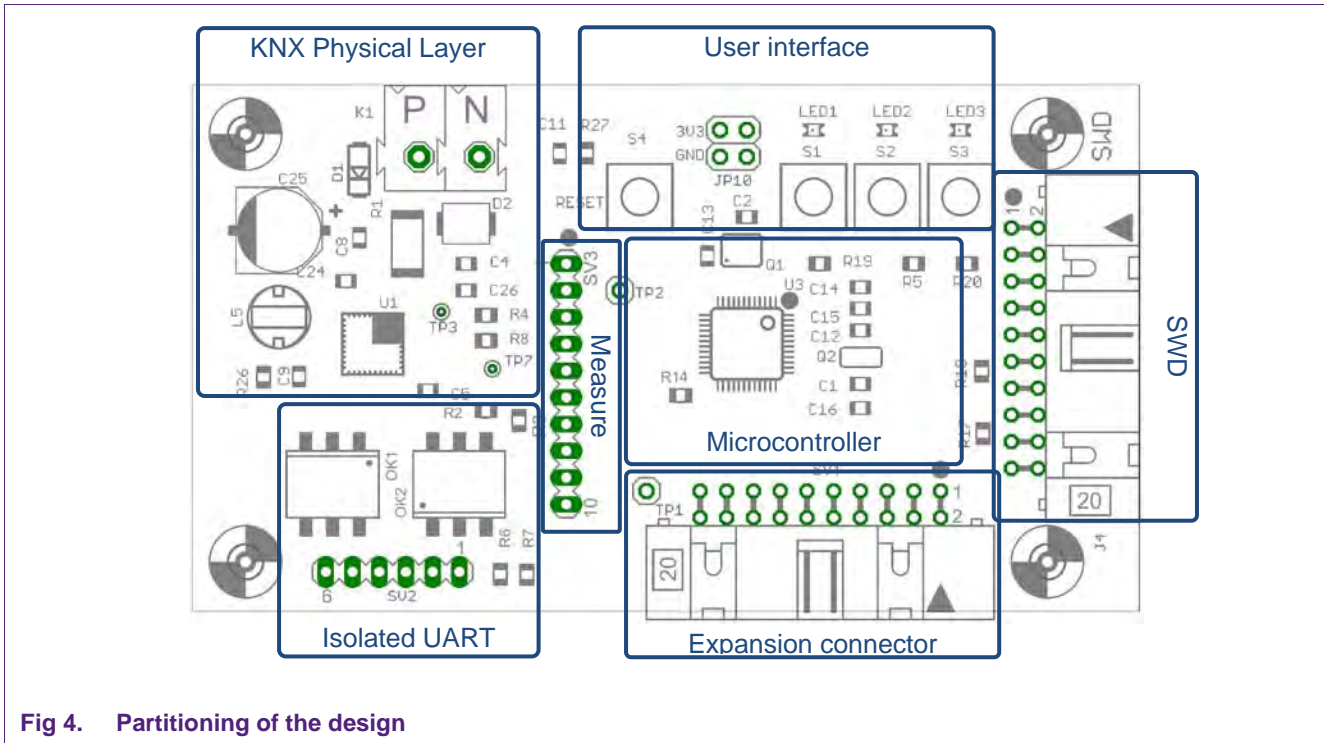

Fig 4. Partitioning of the design

In the middle of the board, a header is available to measure the various signals between the microcontroller and the transceiver. The top part contains the user interaction: LEDs and buttons. The header on the right hand side provides a debug probe connection that complies with the Serial Wire Debug (SWD) interface standard. To interface with other boards an extension connector is present on the lower part of the board. See [Fig 4](#).

3.3 Microcontroller

To allow easy KNX application development, the development board is equipped with an LPC1227 Cortex M0 microcontroller with a flash memory size of 128 kB and 8 kB of RAM. This allows for downgrading to other LPC122x microcontrollers with smaller memory sizes while maintaining software and hardware compatibility. More information on the LPC122x microcontroller series is available in the LPC122x datasheet [\[1\]](#).

The microcontroller uses UART1 to connect to the transceiver. Furthermore, some GPIO's are used to connect to the KNX Phy. The second UART (UART0) on the design can be used to connect an external terminal program for debugging messages. The debug UART is electrically isolated from the design and the KNX bus.

Software can be downloaded via the SWD interface and debugged to the microcontroller on header J4. The LPC1227 user manual [\[2\]](#) contains a full description of the processing core and all the on board peripherals of the microcontroller. [Fig 5](#) gives the schematic of the microcontroller section of the board.

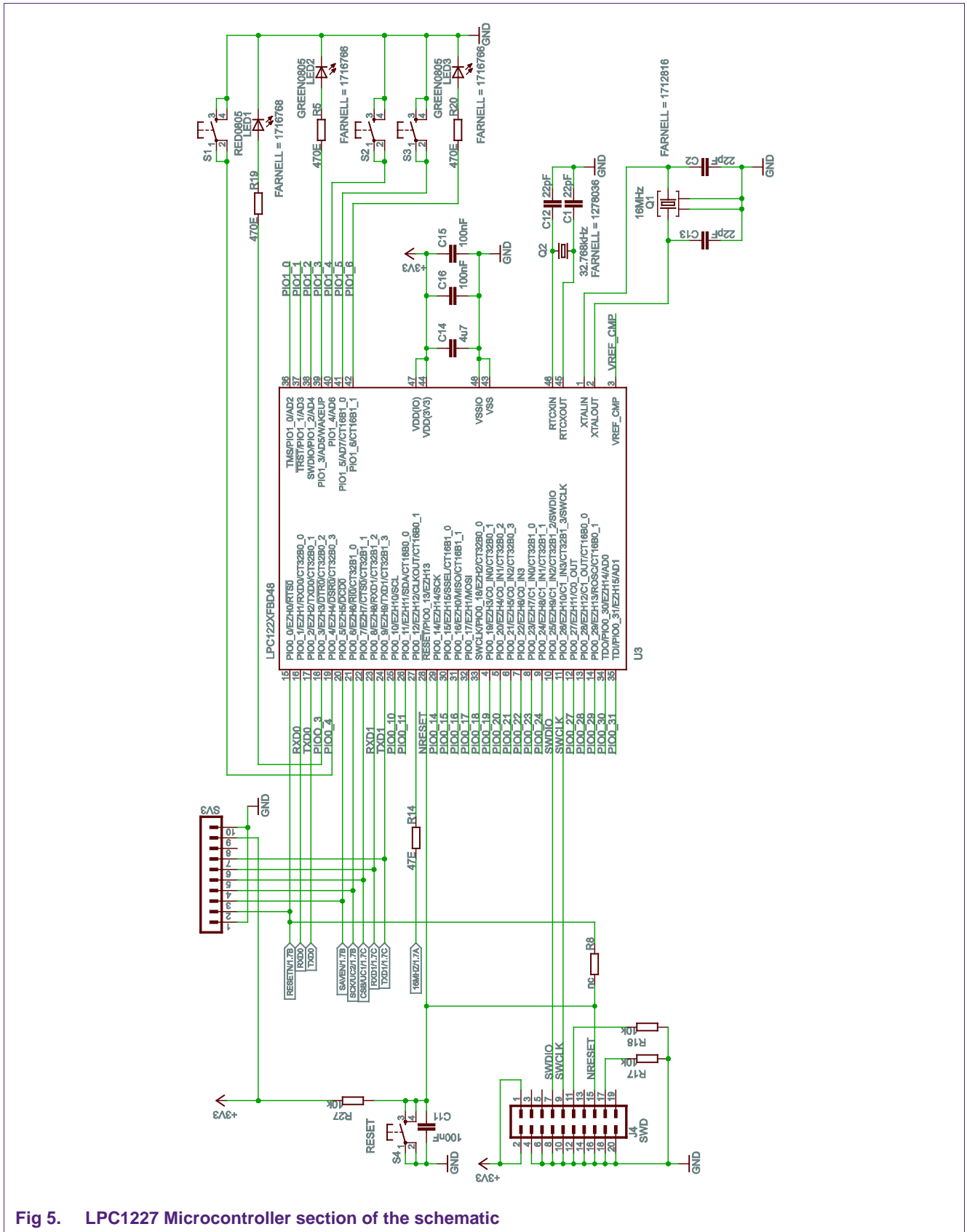
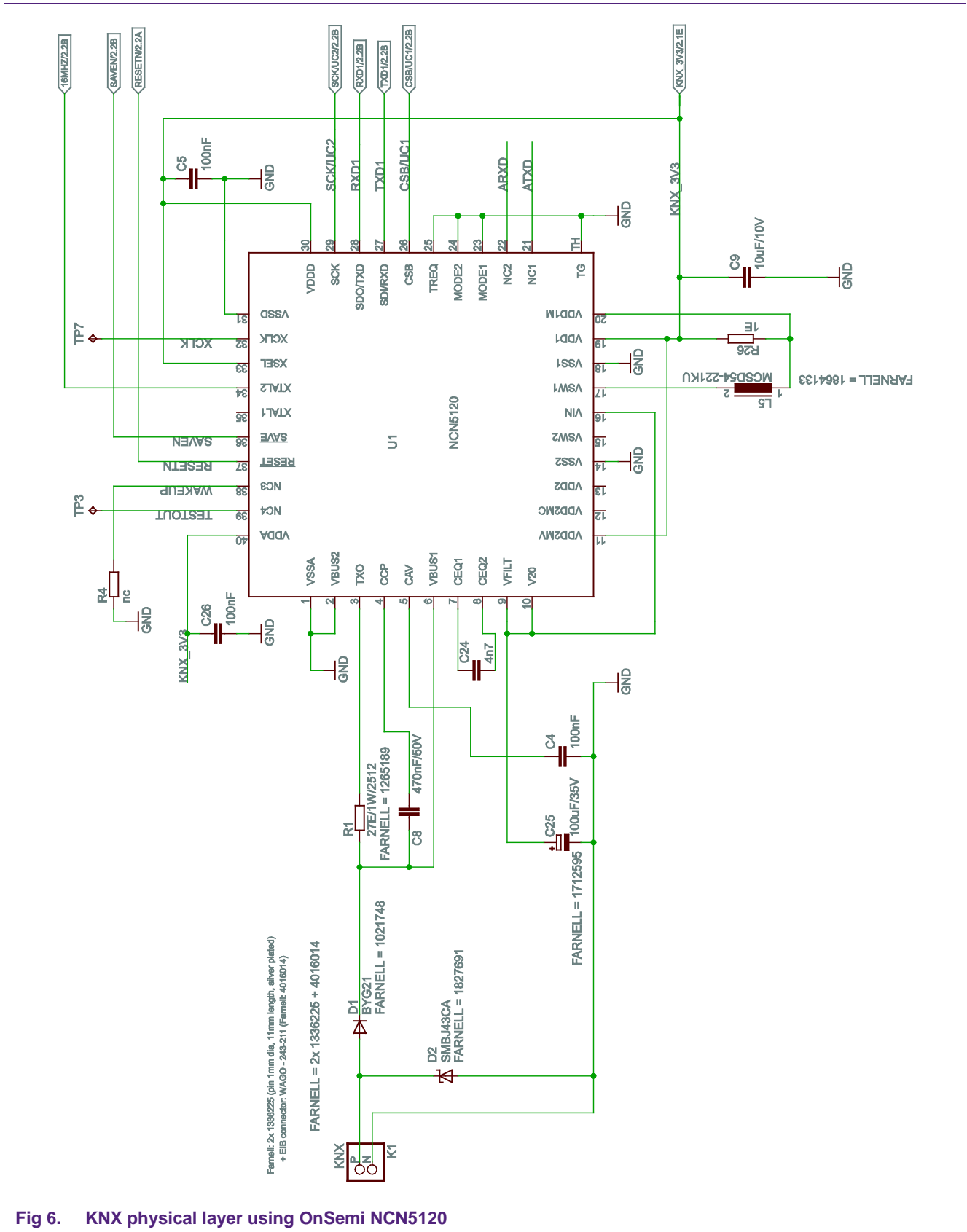

Fig 5. LPC1227 Microcontroller section of the schematic

3.4 KNX physical layer

The twisted pair 1 (TP1) KNX physical layer standard is used in the design. The design uses an NCN5120 receiver-transmitter IC for TP1 communication. The NCN5120 handles the transmission and reception of data on the bus. It generates stabilized voltages from the unregulated KNX bus for its own power needs as well as power for external devices as the microcontroller in this design. The NCN5120 assures safe coupling to and decoupling from the bus. Bus monitoring warns the external microcontroller for loss of power so that critical data can be stored in time.



3.5 Isolated UART interface

The isolated debug UART can be used for showing messages on a terminal. The 6-pin connector is compatible with a TTL-232R-3V3 cable from FTDI (Farnell order code: 1329311). This cable is shown in [Fig 7](#).



Fig 7. FTDI TTL-232R-3V3 cable

[Fig 8](#) gives the schematic diagram of the electrical isolate debug UART. This connection can both be used for input and output to the design and is not necessary for an end product.

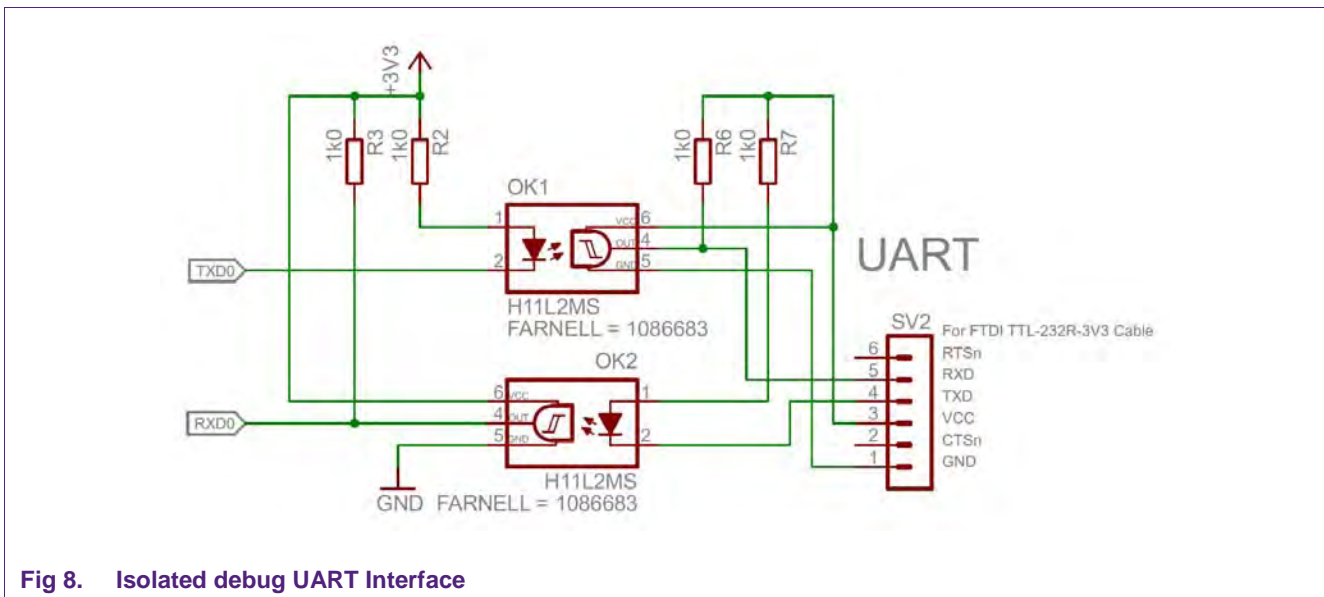

Fig 8. Isolated debug UART Interface

3.6 Expansion connector

To facilitate the connection of external hardware the expansion connector SV1 is available. The expansion connector can be used to connect external hardware boards for lighting, sensor, HVAC or other control purposes.

The connections of the expansion connector are given in [Fig 9](#). All the connections, except ground and power, are directly connected to the microcontroller. The connections available support the usage of the 16-bit timers CTB16B0 and CTB16B1, and the 32-bit timers CT32B0 and CT32B1 for PWM generation. Furthermore, two analog to digital inputs are available; for communication purposes an SPI/SSP or I2C connection is available.

Not all these I/O connections are available simultaneously as the microcontroller uses pin multiplexing to select the specific function of an I/O pin. For detailed information on the pin multiplexing possibilities of the LPC1227 microcontroller see the LPC1227 user manual [2].

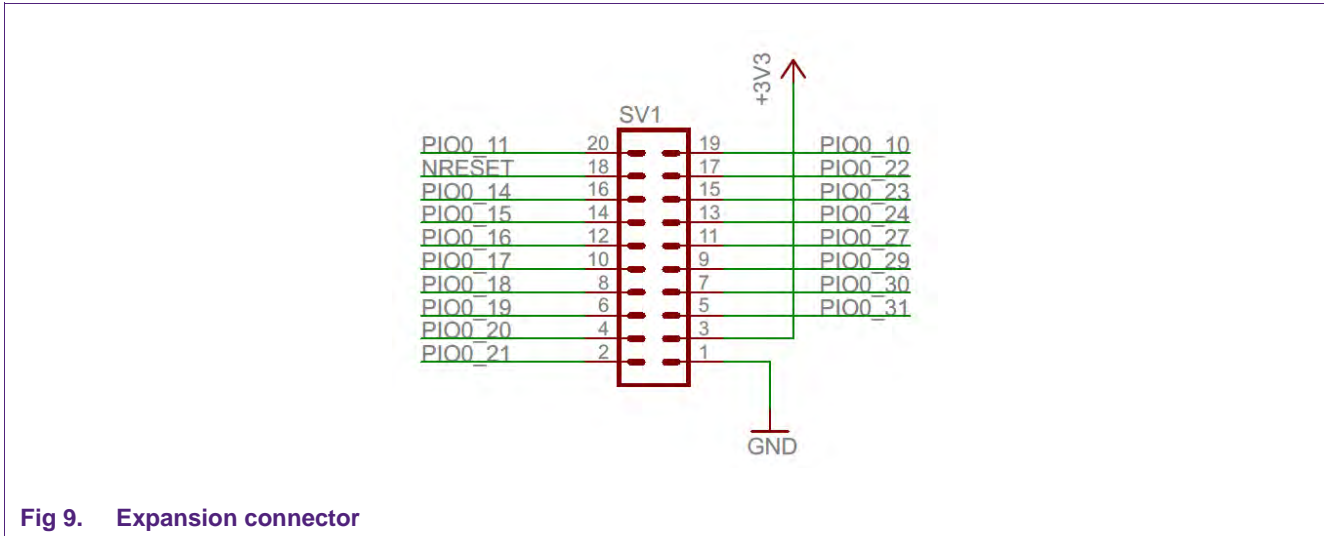

Fig 9. Expansion connector

4. Bill of Materials

Table 1. Component list

Part	Value	Device	Package	Description	Farnell
C1	22pF	C-EUC0805K	C0805K	CAPACITOR, European symbol	
C2	22pF	C-EUC0805K	C0805K	CAPACITOR, European symbol	
C4	100nF	C-EUC0805K	C0805K	CAPACITOR, European symbol	
C5	100nF	C-EUC0805K	C0805K	CAPACITOR, European symbol	
C8	470nF/50V	C-EUC0805K	C0805K	CAPACITOR, European symbol	
C9	10uF/10V/X7R	C-EUC0805K	C0805K	CAPACITOR, European symbol	
C11	100nF	C-EUC0805K	C0805K	CAPACITOR, European symbol	
C12	22pF	C-EUC0805K	C0805K	CAPACITOR, European symbol	
C13	22pF	C-EUC0805K	C0805K	CAPACITOR, European symbol	
C14	4u7	C-EUC0805K	C0805K	CAPACITOR, European symbol	
C15	100nF	C-EUC0805K	C0805K	CAPACITOR, European symbol	
C16	100nF	C-EUC0805K	C0805K	CAPACITOR, European symbol	
C24	4n7	C-EUC0805K	C0805K	CAPACITOR, European symbol	
C25	100uF/35V	CPOL-EUF	PANASONIC_F	POLARIZED CAPACITOR, European symbol	1712595
C26	100nF	C-EUC0805K	C0805K	CAPACITOR, European symbol	
D1	BYG21	DIODE-DO214AC	DO214AC	DIODE	1021748
D2	SMBJ43CA	SUPPRESSOR-SMBJ	SMBJ	Suppressor diode	1827691
J4	MC9A22-2034	MC9A22-2034		HEADER, RIGHT ANGLE, 20 WAY	1099248
JP10		PINHD-2X2	2X02	PIN HEADER	
K1	KNX	KNX	KNX	TP1 pins and connector	2x 1336225 + 4016014
L5	220uH	NPI54C221KTRF	5.8x5.2	NIC Components, SMD non-shielded	RS online 740-9619
LED1	RED0805	LEDCHIPLED_0805	CHIPLED_0805	LED (Check Anode/Cathode placement!)	1716768
LED2	GREEN0805	LEDCHIPLED_0805	CHIPLED_0805	LED	1716766
LED3	GREEN0805	LEDCHIPLED_0805	CHIPLED_0805	LED	1716766
OK1	H11L2MS	H11L2MS	DIL6-SMD	6-Pin DIP Optocoupler	1086683
OK2	H11L2MS	H11L2MS	DIL6-SMD	6-Pin DIP Optocoupler	1086683
Q1	16MHz	CRYSTAL4	XTAL4		1712816
Q2	32.768kHz	RTCCRYSTAL	XTAL2		1278036
R1	27E/1W/2512	R-EU_R2512	R2512	RESISTOR, European symbol, +/- 5%	1265189
R2	1k0	R-EU_R0805	R0805	RESISTOR, European symbol	
R3	1k0	R-EU_R0805	R0805	RESISTOR, European symbol	
R4	nc	R-EU_R0805	R0805	RESISTOR, European symbol	

Part	Value	Device	Package	Description	Farnell
R5	470E	R-EU_R0805	R0805	RESISTOR, European symbol	
R6	1k0	R-EU_R0805	R0805	RESISTOR, European symbol	
R7	1k0	R-EU_R0805	R0805	RESISTOR, European symbol	
R8	nc	R-EU_R0805	R0805	RESISTOR, European symbol	
R14	47E	R-EU_R0805	R0805	RESISTOR, European symbol	
R17	10k	R-EU_R0805	R0805	RESISTOR, European symbol	
R18	10k	R-EU_R0805	R0805	RESISTOR, European symbol	
R19	470E	R-EU_R0805	R0805	RESISTOR, European symbol	
R20	470E	R-EU_R0805	R0805	RESISTOR, European symbol	
R26	1E	R-EU_R0805	R0805	RESISTOR, European symbol	
R27	10k	R-EU_R0805	R0805	RESISTOR, European symbol	
S1	B3FS-1000	B3FS-1000	SWITCH-TACT_DTSM-6	OMRON ELECTRONIC COMPONENTS - B3FS-1000 - SWITCH, FLAT, SPNO	3121161
S2	B3FS-1000	B3FS-1000	SWITCH-TACT_DTSM-6	OMRON ELECTRONIC COMPONENTS - B3FS-1000 - SWITCH, FLAT, SPNO	3121161
S3	B3FS-1000	B3FS-1000	SWITCH-TACT_DTSM-6	OMRON ELECTRONIC COMPONENTS - B3FS-1000 - SWITCH, FLAT, SPNO	3121161
S4	B3FS-1000	B3FS-1000	SWITCH-TACT_DTSM-6	OMRON ELECTRONIC COMPONENTS - B3FS-1000 - SWITCH, FLAT, SPNO	3121161
SV1	MC9A22-2034	MC9A22-2034		HEADER, RIGHT ANGLE, 20 WAY	1099248
SV2		MA06-1	MA06-1	PIN HEADER	
SV3		MA10-1	MA10-1	PIN HEADER	
TP1		PINHD-1X1	1X01	PIN HEADER	
TP2		PINHD-1X1	1X01	PIN HEADER	
U1	NCN5120	NCN5120	QFN40_6X6_NCN5120	On Semiconductor KNX TP1 transceiver	
U3	LPC1227FBD48	LPC122XFBD48	SOT313-2	NXP ARM Cortex M0 32 bit Microcontroller	1862476

5. Device configuration

The demo board is programmed with the App_DemoBoardNXP_LPC12xx.hex file to create an example KNX device. Together with an example project for the ETS tool (the manufacturer independent configuration tool from KNX Association), the user can setup a small KNX network using the OM13042 board.

The example application file for the microcontroller contains a limited version of the KNX stack from Weinzierl Engineering. For more information on the KNX system stack refer to Weinzierl Engineering [\[4\]](#).

Table 2. Accompanying files AN11231

File name	Description
App_DemoBoardNXP_LPC12xx.hex	Flash file for the LPC1227 microcontroller
Test_Project_App_Demo_NXP_2012_04_11.pr5	Example project for KNX ETS configuration tool

6. References

- [1] Product data sheet LPC122x 32-bit ARM Cortex-M0 microcontroller, Rev. 2 — 26 August 2011 http://www.nxp.com/documents/data_sheet/LPC122X.pdf
- [2] UM10441, LPC1224/25/26/27 User manual, Rev. 2 — 19 September 2011, http://www.nxp.com/documents/user_manual/UM10441.pdf
- [3] NCN5120 datasheet, Rev.1 – May 2011 On Semiconductors
- [4] Weinzierl Engineering GmbH, <http://www.weinzierl.de/>

7. Legal information

7.1 Definitions

Draft — The document is a draft version only. The content is still under internal review and subject to formal approval, which may result in modifications or additions. NXP Semiconductors does not give any representations or warranties as to the accuracy or completeness of information included herein and shall have no liability for the consequences of use of such information.

7.2 Disclaimers

Limited warranty and liability — Information in this document is believed to be accurate and reliable. However, NXP Semiconductors does not give any representations or warranties, expressed or implied, as to the accuracy or completeness of such information and shall have no liability for the consequences of use of such information. NXP Semiconductors takes no responsibility for the content in this document if provided by an information source outside of NXP Semiconductors.

In no event shall NXP Semiconductors be liable for any indirect, incidental, punitive, special or consequential damages (including - without limitation - lost profits, lost savings, business interruption, costs related to the removal or replacement of any products or rework charges) whether or not such damages are based on tort (including negligence), warranty, breach of contract or any other legal theory.

Notwithstanding any damages that customer might incur for any reason whatsoever, NXP Semiconductors' aggregate and cumulative liability towards customer for the products described herein shall be limited in accordance with the Terms and conditions of commercial sale of NXP Semiconductors.

Right to make changes — NXP Semiconductors reserves the right to make changes to information published in this document, including without limitation specifications and product descriptions, at any time and without notice. This document supersedes and replaces all information supplied prior to the publication hereof.

Suitability for use — NXP Semiconductors products are not designed, authorized or warranted to be suitable for use in life support, life-critical or safety-critical systems or equipment, nor in applications where failure or malfunction of an NXP Semiconductors product can reasonably be expected to result in personal injury, death or severe property or environmental damage. NXP Semiconductors and its suppliers accept no liability for inclusion and/or use of NXP Semiconductors products in such equipment or applications and therefore such inclusion and/or use is at the customer's own risk.

Applications — Applications that are described herein for any of these products are for illustrative purposes only. NXP Semiconductors makes no representation or warranty that such applications will be suitable for the specified use without further testing or modification.

Customers are responsible for the design and operation of their applications and products using NXP Semiconductors products, and NXP

Semiconductors accepts no liability for any assistance with applications or customer product design. It is customer's sole responsibility to determine whether the NXP Semiconductors product is suitable and fit for the customer's applications and products planned, as well as for the planned application and use of customer's third party customer(s). Customers should provide appropriate design and operating safeguards to minimize the risks associated with their applications and products.

NXP Semiconductors does not accept any liability related to any default, damage, costs or problem which is based on any weakness or default in the customer's applications or products, or the application or use by customer's third party customer(s). Customer is responsible for doing all necessary testing for the customer's applications and products using NXP Semiconductors products in order to avoid a default of the applications and the products or of the application or use by customer's third party customer(s). NXP does not accept any liability in this respect.

Export control — This document as well as the item(s) described herein may be subject to export control regulations. Export might require a prior authorization from competent authorities.

Evaluation products — This product is provided on an "as is" and "with all faults" basis for evaluation purposes only. NXP Semiconductors, its affiliates and their suppliers expressly disclaim all warranties, whether express, implied or statutory, including but not limited to the implied warranties of non-infringement, merchantability and fitness for a particular purpose. The entire risk as to the quality, or arising out of the use or performance, of this product remains with customer.

In no event shall NXP Semiconductors, its affiliates or their suppliers be liable to customer for any special, indirect, consequential, punitive or incidental damages (including without limitation damages for loss of business, business interruption, loss of use, loss of data or information, and the like) arising out the use of or inability to use the product, whether or not based on tort (including negligence), strict liability, breach of contract, breach of warranty or any other theory, even if advised of the possibility of such damages.

Notwithstanding any damages that customer might incur for any reason whatsoever (including without limitation, all damages referenced above and all direct or general damages), the entire liability of NXP Semiconductors, its affiliates and their suppliers and customer's exclusive remedy for all of the foregoing shall be limited to actual damages incurred by customer based on reasonable reliance up to the greater of the amount actually paid by customer for the product or five dollars (US\$5.00). The foregoing limitations, exclusions and disclaimers shall apply to the maximum extent permitted by applicable law, even if any remedy fails of its essential purpose.

7.3 Trademarks

Notice: All referenced brands, product names, service names and trademarks are property of their respective owners.

8. List of figures

Fig 1. OM 13042 KNX TP1 NCN5120 LPC1227 evaluation board3

Fig 2. Evaluation board overview4

Fig 3. Component placement top side4

Fig 4. Partitioning of the design5

Fig 5. LPC1227 Microcontroller section of the schematic.....6

Fig 6. KNX physical layer using OnSemi NCN5120....8

Fig 7. FTDI TTL-232R-3V3 cable9

Fig 8. Isolated debug UART Interface.....9

Fig 9. Expansion connector 10

9. List of tables

Table 1.	Component list	11
Table 2.	Accompanying files AN11231	13

10. Contents

1.	Document purpose	3
2.	Introduction	3
3.	Hardware	3
3.1	Overview	3
3.2	PCB overview.....	4
3.3	Microcontroller.....	5
3.4	KNX physical layer	7
3.5	Isolated UART interface	9
3.6	Expansion connector.....	9
4.	Bill of Materials	11
5.	Device configuration	13
6.	References	14
7.	Legal information	15
7.1	Definitions	15
7.2	Disclaimers.....	15
7.3	Trademarks	15
8.	List of figures	16
9.	List of tables	17
10.	Contents	18

Please be aware that important notices concerning this document and the product(s) described herein, have been included in the section 'Legal information'.

© NXP B.V. 2012.

All rights reserved.

For more information, visit: <http://www.nxp.com>

For sales office addresses, please send an email to: salesaddresses@nxp.com

Date of release: 1 July 2012

Document identifier: AN11231