

DATA SHEET

TDA7050T

Low voltage mono/stereo power
amplifier

Product specification
File under Integrated Circuits, IC01

July 1994

Low voltage mono/stereo power amplifier

TDA7050T

GENERAL DESCRIPTION

The TDA7050T is a low voltage audio amplifier for small radios with headphones (such as watch, pen and pocket radios) in mono (bridge-tied load) or stereo applications.

Features

- Limited to battery supply application only (typ. 3 and 4 V)
- Operates with supply voltage down to 1,6 V
- No external components required
- Very low quiescent current
- Fixed integrated gain of 26 dB, floating differential input
- Flexibility in use – mono BTL as well as stereo
- Small dimension of encapsulation (see package design example).

QUICK REFERENCE DATA

Supply voltage range	V_P		1,6 to 6,0 V
Total quiescent current (at $V_P = 3$ V)	I_{tot}	typ.	3,2 mA
Bridge tied load application (BTL)			
Output power at $R_L = 32 \Omega$ $V_P = 3$ V; $d_{tot} = 10\%$	P_o	typ.	140 mW
D.C. output offset voltage between the outputs	$ \Delta V $	max.	70 mV
Noise output voltage (r.m.s. value) at $f = 1$ kHz; $R_S = 5$ k Ω	$V_{no(rms)}$	typ.	140 μ V
Stereo application			
Output power at $R_L = 32 \Omega$ $d_{tot} = 10\%$; $V_P = 3$ V	P_o	typ.	35 mW
$d_{tot} = 10\%$; $V_P = 4,5$ V	P_o	typ.	75 mW
Channel separation at $R_S = 0 \Omega$; $f = 1$ kHz	α	typ.	40 dB
Noise output voltage (r.m.s. value) at $f = 1$ kHz; $R_S = 5$ k Ω	$V_{no(rms)}$	typ.	100 μ V

PACKAGE OUTLINE

8-lead mini-pack; plastic (SO8; SOT96A); SOT96-1; 1996 July 24.

Low voltage mono/stereo power amplifier

TDA7050T

RATINGS

Limiting values in accordance with the Absolute Maximum System (IEC 134)

Supply voltage	V_P	max.	6 V
Peak output current	I_{OM}	max.	150 mA
Total power dissipation			see derating curve Fig.1
Storage temperature range	T_{stg}		-55 to + 150 °C
Crystal temperature	T_c	max.	100 °C
A.C. and d.c. short-circuit duration at $V_P = 3,0$ V (during mishandling)	t_{sc}	max.	5 s

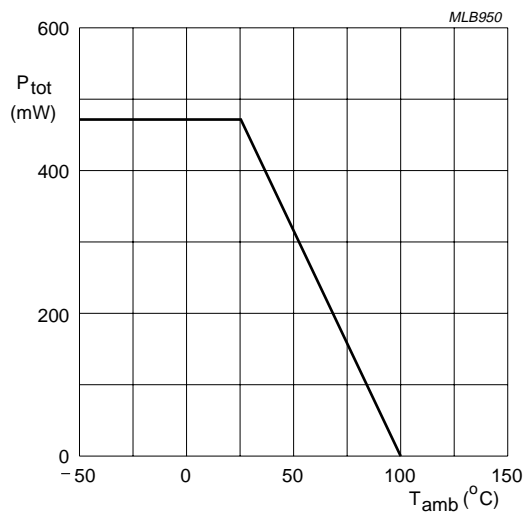

Fig.1 Power derating curve.

SO PACKAGE DESIGN EXAMPLE

To achieve the small dimension of the encapsulation the SO package is preferred with only 8 pins. Because a heatsink is not applicable, the dissipation is limited by the thermal resistance of the 8-pin SO encapsulation until:

$$\frac{T_{j\max} - T_{amb}}{R_{th\ j-a}} = \frac{100 - 60}{160} = 0.25 \text{ W}$$

Low voltage mono/stereo power amplifier

TDA7050T

CHARACTERISTICS

$V_P = 3\text{ V}$; $f = 1\text{ kHz}$; $R_L = 32\ \Omega$; $T_{\text{amb}} = 25\text{ }^\circ\text{C}$; unless otherwise specified

PARAMETER	SYMBOL	MIN.	TYP.	MAX.	UNIT
Supply					
Supply voltage	V_P	1,6	–	6,0	V
Total quiescent current	I_{tot}	–	3,2	4	mA
Bridge-tied load application (BTL); see Fig.4					
Output power*					
$V_P = 3,0\text{ V}$; $d_{\text{tot}} = 10\%$	P_o	–	140	–	mW
$V_P = 4,5\text{ V}$; $d_{\text{tot}} = 10\%$ ($R_L = 64\ \Omega$)	P_o	–	150	–	mW
Voltage gain	G_V	–	32	–	dB
Noise output voltage (r.m.s. value)					
$R_S = 5\text{ k}\Omega$; $f = 1\text{ kHz}$	$V_{\text{no(rms)}}$	–	140	–	μV
$R_S = 0\ \Omega$; $f = 500\text{ kHz}$; $B = 5\text{ kHz}$	$V_{\text{no(rms)}}$	–	tbf	–	μV
D.C. output offset voltage (at $R_S = 5\text{ k}\Omega$)	$ \Delta V $	–	–	70	mV
Input impedance (at $R_S = \infty$)	$ Z_i $	1	–	–	$\text{M}\Omega$
Input bias current	I_i	–	40	–	nA
Stereo application; see Fig.5					
Output power*					
$V_P = 3,0\text{ V}$; $d_{\text{tot}} = 10\%$	P_o	–	35	–	mW
$V_P = 4,5\text{ V}$; $d_{\text{tot}} = 10\%$	P_o	–	75	–	mW
Voltage gain	G_V	24.5	26	27.5	dB
Noise output voltage (r.m.s. value)					
$R_S = 5\text{ k}\Omega$; $f = 1\text{ kHz}$	$V_{\text{no(rms)}}$	–	100	–	μV
$R_S = 0\ \Omega$; $f = 500\text{ kHz}$; $B = 5\text{ kHz}$	$V_{\text{no(rms)}}$	–	tbf	–	μV
Channel separation					
$R_S = 0\ \Omega$; $f = 1\text{ kHz}$	α	30	40	–	dB
Input impedance (at $R_S = \infty$)	$ Z_i $	2	–	–	$\text{M}\Omega$
Input bias current	I_i	–	20	–	nA

* Output power is measured directly at the output pins of the IC. It is shown as a function of the supply voltage in Fig.2 (BTL application) and Fig.3 (stereo application).

Low voltage mono/stereo power amplifier

TDA7050T

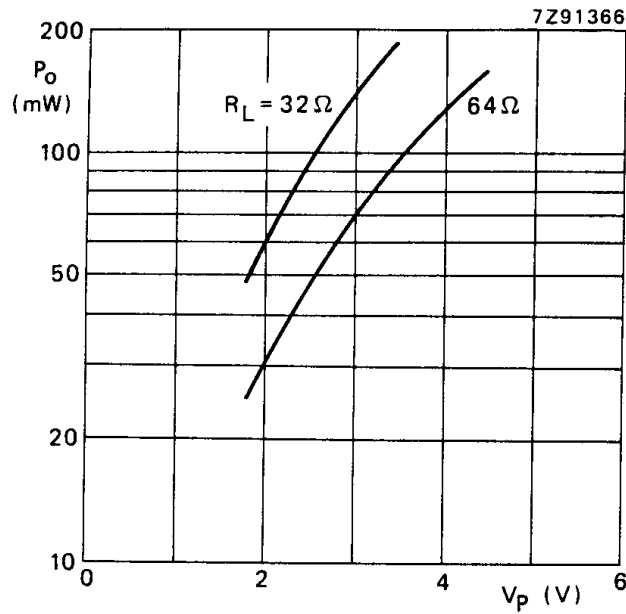

Fig.2 Output power across the load impedance (R_L) as a function of supply voltage (V_p) in BTL application. Measurements were made at $f = 1 \text{ kHz}$; $d_{tot} = 10\%$; $T_{amb} = 25 \text{ }^\circ\text{C}$.

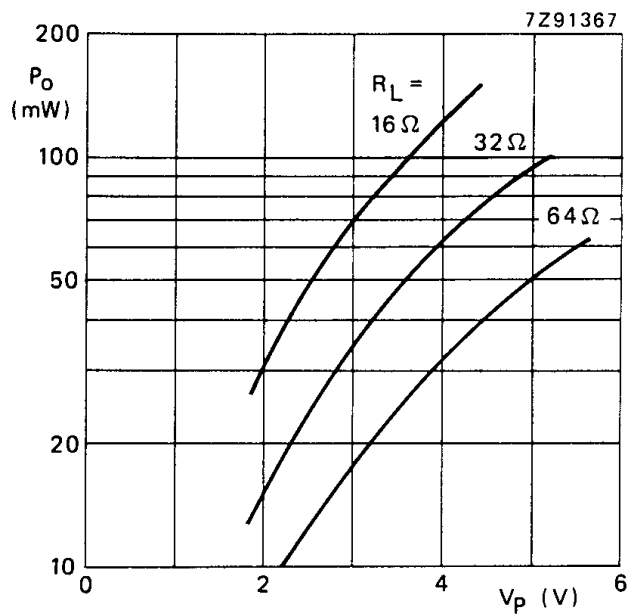
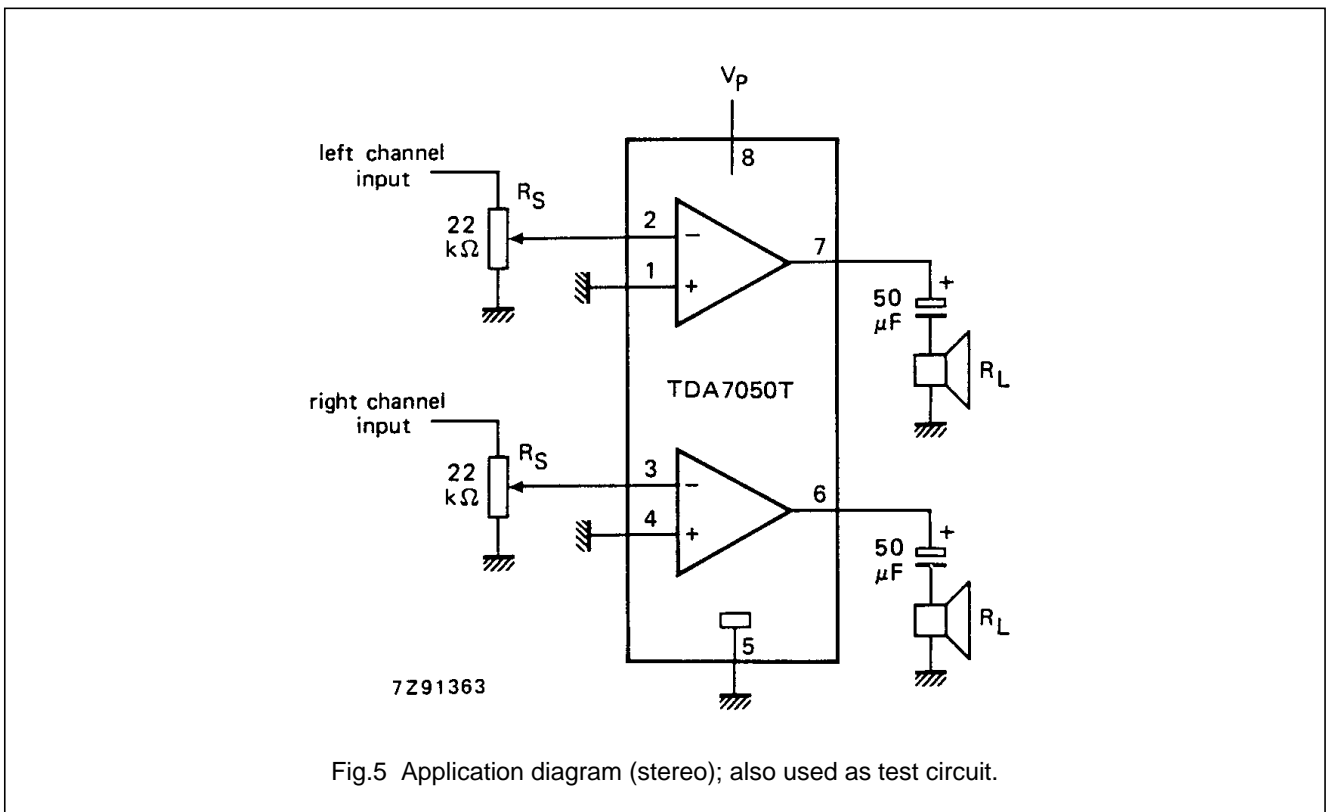
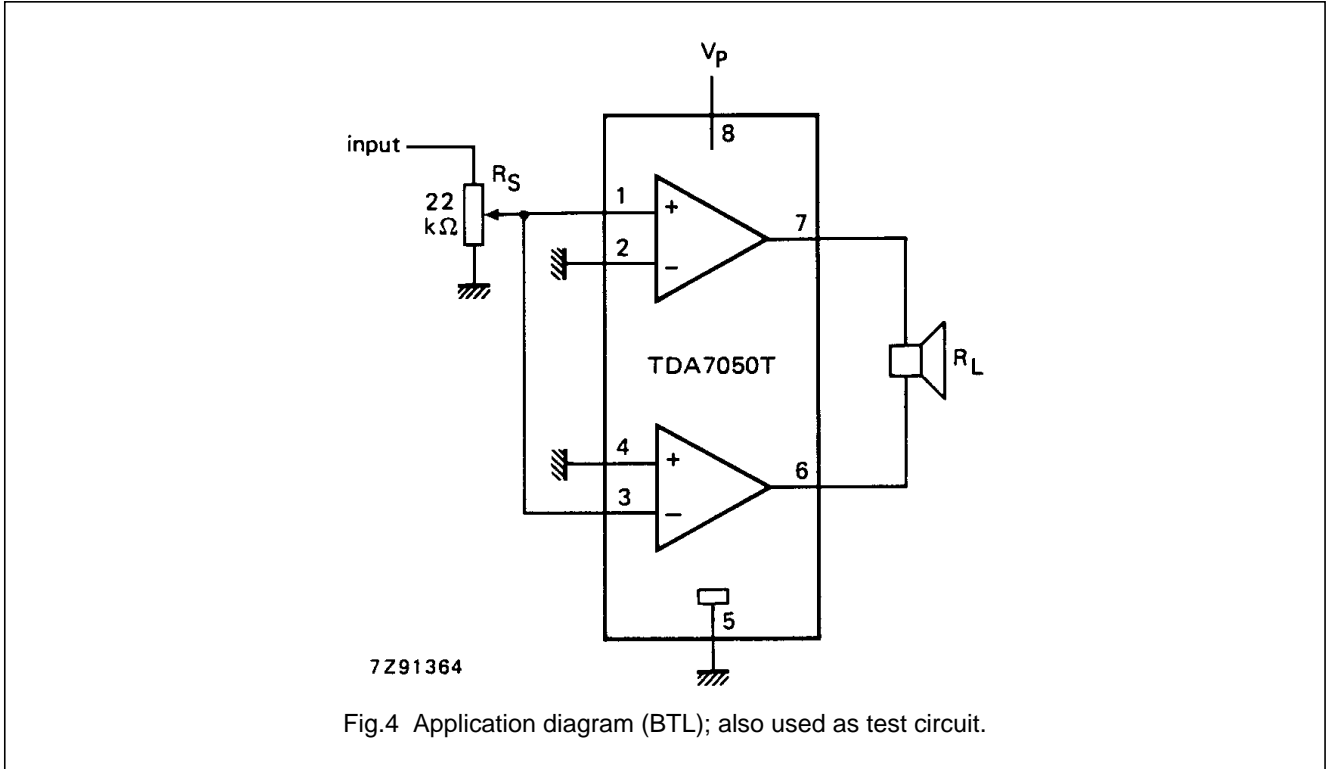

Fig.3 Output power across the load impedance (R_L) as a function of supply voltage (V_p) in stereo application. Measurements were made at $f = 1 \text{ kHz}$; $d_{tot} = 10\%$; $T_{amb} = 25 \text{ }^\circ\text{C}$.

Low voltage mono/stereo power amplifier

TDA7050T

APPLICATION INFORMATION



Low voltage mono/stereo power amplifier

TDA7050T

PACKAGE OUTLINE

SO8: plastic small outline package; 8 leads; body width 3.9 mm

SOT96-1

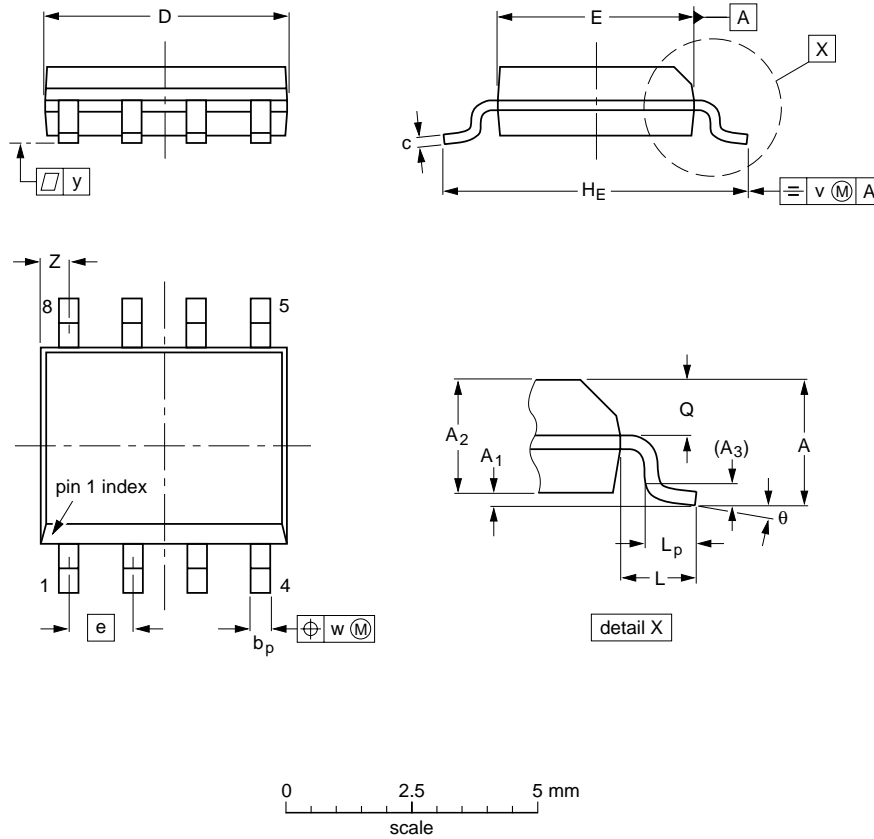

DIMENSIONS (inch dimensions are derived from the original mm dimensions)

UNIT	A max.	A ₁	A ₂	A ₃	b _p	c	D ⁽¹⁾	E ⁽²⁾	e	H _E	L	L _p	Q	v	w	y	z ⁽¹⁾	θ
mm	1.75	0.25 0.10	1.45 1.25	0.25	0.49 0.36	0.25 0.19	5.0 4.8	4.0 3.8	1.27	6.2 5.8	1.05	1.0 0.4	0.7 0.6	0.25	0.25	0.1	0.7 0.3	8° 0°
inches	0.069	0.010 0.004	0.057 0.049	0.01	0.019 0.014	0.0100 0.0075	0.20 0.19	0.16 0.15	0.050	0.244 0.228	0.041	0.039 0.016	0.028 0.024	0.01	0.01	0.004	0.028 0.012	

Notes

1. Plastic or metal protrusions of 0.15 mm maximum per side are not included.
2. Plastic or metal protrusions of 0.25 mm maximum per side are not included.

OUTLINE VERSION	REFERENCES				EUROPEAN PROJECTION	ISSUE DATE
	IEC	JEDEC	EIAJ			
SOT96-1	076E03S	MS-012AA				95-02-04 97-05-22

Low voltage mono/stereo power amplifier

TDA7050T

SOLDERING

Introduction

There is no soldering method that is ideal for all IC packages. Wave soldering is often preferred when through-hole and surface mounted components are mixed on one printed-circuit board. However, wave soldering is not always suitable for surface mounted ICs, or for printed-circuits with high population densities. In these situations reflow soldering is often used.

This text gives a very brief insight to a complex technology. A more in-depth account of soldering ICs can be found in our "IC Package Databook" (order code 9398 652 90011).

Reflow soldering

Reflow soldering techniques are suitable for all SO packages.

Reflow soldering requires solder paste (a suspension of fine solder particles, flux and binding agent) to be applied to the printed-circuit board by screen printing, stencilling or pressure-syringe dispensing before package placement.

Several techniques exist for reflowing; for example, thermal conduction by heated belt. Dwell times vary between 50 and 300 seconds depending on heating method. Typical reflow temperatures range from 215 to 250 °C.

Preheating is necessary to dry the paste and evaporate the binding agent. Preheating duration: 45 minutes at 45 °C.

Wave soldering

Wave soldering techniques can be used for all SO packages if the following conditions are observed:

- A double-wave (a turbulent wave with high upward pressure followed by a smooth laminar wave) soldering technique should be used.
- The longitudinal axis of the package footprint must be parallel to the solder flow.
- The package footprint must incorporate solder thieves at the downstream end.

During placement and before soldering, the package must be fixed with a droplet of adhesive. The adhesive can be applied by screen printing, pin transfer or syringe dispensing. The package can be soldered after the adhesive is cured.

Maximum permissible solder temperature is 260 °C, and maximum duration of package immersion in solder is 10 seconds, if cooled to less than 150 °C within 6 seconds. Typical dwell time is 4 seconds at 250 °C.

A mildly-activated flux will eliminate the need for removal of corrosive residues in most applications.

Repairing soldered joints

Fix the component by first soldering two diagonally-opposite end leads. Use only a low voltage soldering iron (less than 24 V) applied to the flat part of the lead. Contact time must be limited to 10 seconds at up to 300 °C. When using a dedicated tool, all other leads can be soldered in one operation within 2 to 5 seconds between 270 and 320 °C.

Low voltage mono/stereo power amplifier

TDA7050T

DEFINITIONS

Data sheet status	
Objective specification	This data sheet contains target or goal specifications for product development.
Preliminary specification	This data sheet contains preliminary data; supplementary data may be published later.
Product specification	This data sheet contains final product specifications.
Limiting values	
Limiting values given are in accordance with the Absolute Maximum Rating System (IEC 134). Stress above one or more of the limiting values may cause permanent damage to the device. These are stress ratings only and operation of the device at these or at any other conditions above those given in the Characteristics sections of the specification is not implied. Exposure to limiting values for extended periods may affect device reliability.	
Application information	
Where application information is given, it is advisory and does not form part of the specification.	

LIFE SUPPORT APPLICATIONS

These products are not designed for use in life support appliances, devices, or systems where malfunction of these products can reasonably be expected to result in personal injury. Philips customers using or selling these products for use in such applications do so at their own risk and agree to fully indemnify Philips for any damages resulting from such improper use or sale.