

Module subsystem  
for solid-state  
energy

## RFEM24-250 2.45 GHz RF Energy Module

The RFEM24-250 is a fully integrated 2.45 GHz, 250 W RF generator module that includes full measurement capabilities. Its microcontroller includes an RF source that drives a 3-stage RF amplifier lineup. Its comprehensive command set controls parameters such as frequency, phase and power. The extensive measurement system provides calibrated data from multiple internal sensors and supports closed loop operations.

### FEATURES

- ▶ RF module subsystem with integrated RF source
- ▶ 50 ohm output port
- ▶ I<sup>2</sup>C communications interface
- ▶ Comprehensive sensing includes:
  - ▶ forward and reflected RF power
  - ▶ current and voltage
  - ▶ temperature
- ▶ Integrated hardware-based fault protection
- ▶ Up to 4 modules can be combined and synchronized

### TYPICAL PERFORMANCE

Frequency	2400-2500 MHz
RF power output	250 W @ 30 V
Efficiency	57%
Output amplifier power	24-32 V, 15 A Max
VSWR	Unlimited
RF power measurement	± 5%
Control power	5 V, 0.5 A Max



## CHOOSING A SOLUTION

Which Solution Works Best for Me?

- ▶ RFEL24-500
- ▶ RFEM24-250
- ▶ RFEP24-300



RFEM24-250 RF energy module includes:

- ▶ I<sup>2</sup>C controlled module
- ▶ Interface documentation for module runtime software

User needs to supply:

- ▶ Cooling system (heatsink, fans), 30-32 V, 500 W power supply unit, USB to I<sup>2</sup>C interface
- ▶ Software for interacting with the module



RFEL24-500 RF energy lab box is a complete turnkey solution including two modules and hardware peripherals as well as a PC-based GUI and API (object code only).



RFEP24-300 RF energy pallet is a reference design that includes pre-driver, driver and final-stage amplifiers.

Note: Schematics and layout of the hardware are not included (module is not a reference design)

## HARDWARE OVERVIEW

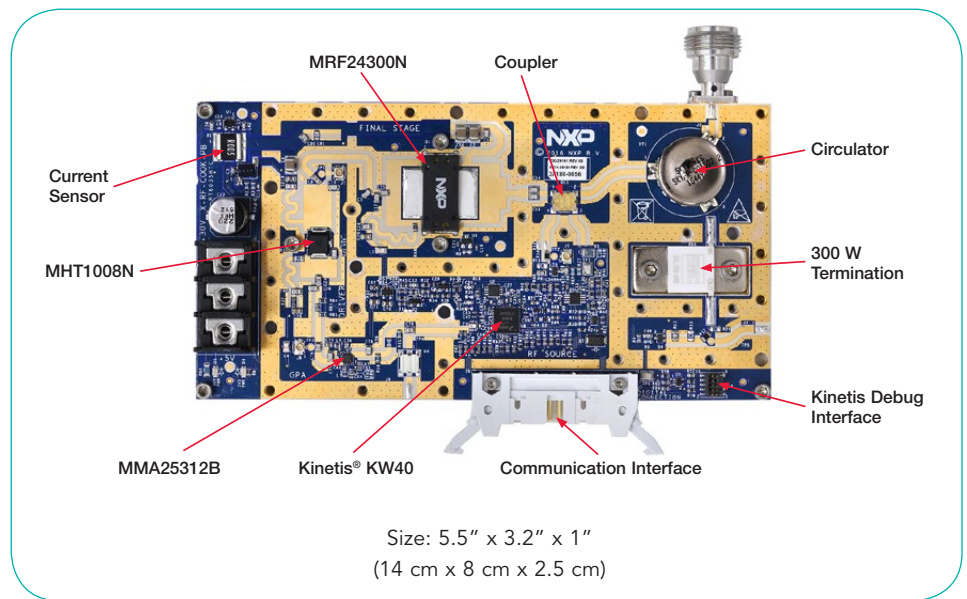

## BLOCK DIAGRAM

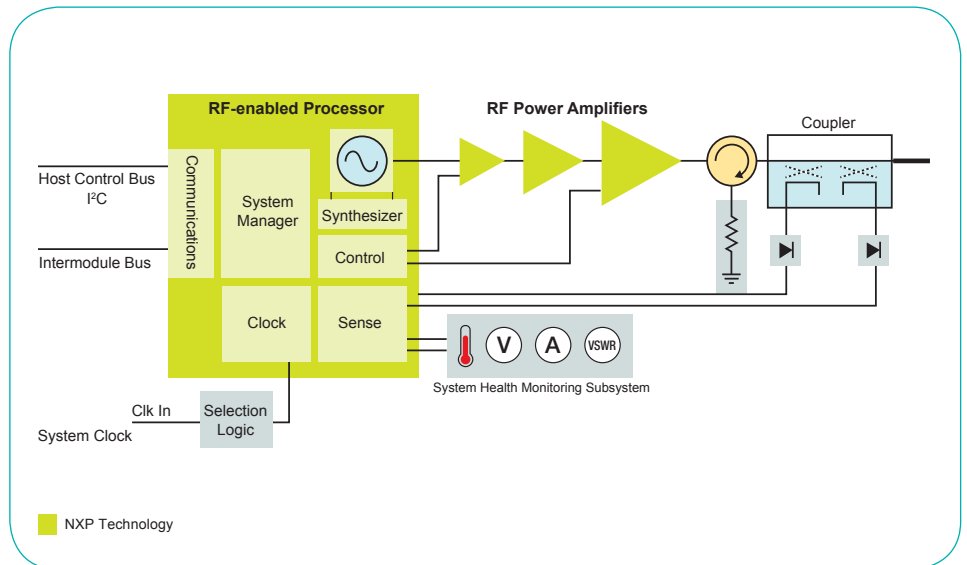

[www.nxp.com/RFenergy](http://www.nxp.com/RFenergy)

NXP and the NXP logo are trademarks of NXP B.V. All other product or service names are the property of their respective owners.  
© 2018 NXP B.V.

RFEM24-250FS Rev. 1  
6/2018