

# 38-38.5 GHz RF 4-channel voltage controlled oscillator front-end for W-band radar applications

The MR2001 is a scalable three package solution for automotive radar modules. The chipset consists of a four channel VCO (voltage controlled oscillator), a two-channel Tx transmitter, and a three-channel Rx receiver. The MR2001V is a high performance, highly integrated, four-channel VCO, ideally suited for automotive radar applications. In conjunction with the MR2001T, the two-channel transmitter, and the MR2001R, a three-channel receiver, it provides a scalable three package solution for automotive radar modules.

## Features

- 38 GHz to 38.5 GHz LO output
- Supply voltage 3.3 V, 4.5 V
- Supply current typ. 180 mA, 50 mA
- Power dissipation typ. 0.8 W
- KVCO 2.5 GHz/V
- Pushing typ. 250 MHz/V
- Static Pulling < 10 MHz
- Phase Noise typ. -95 dBc/Hz at 1.0 MHz
- LO Power min. 3.0 dBm
- Power Control (4 steps)

MR2001V

ADVANCED DRIVER ASSISTANCE SYSTEM

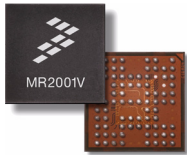

VK SUFFIX (PB-FREE)  
98ASA00540D  
6.0 X 6.0 X 0.95 RCPBGA

## Applications

- Automotive proximity radar
- LRR, MRR and SRR
- ADAS
- Industrial surveillance and security systems

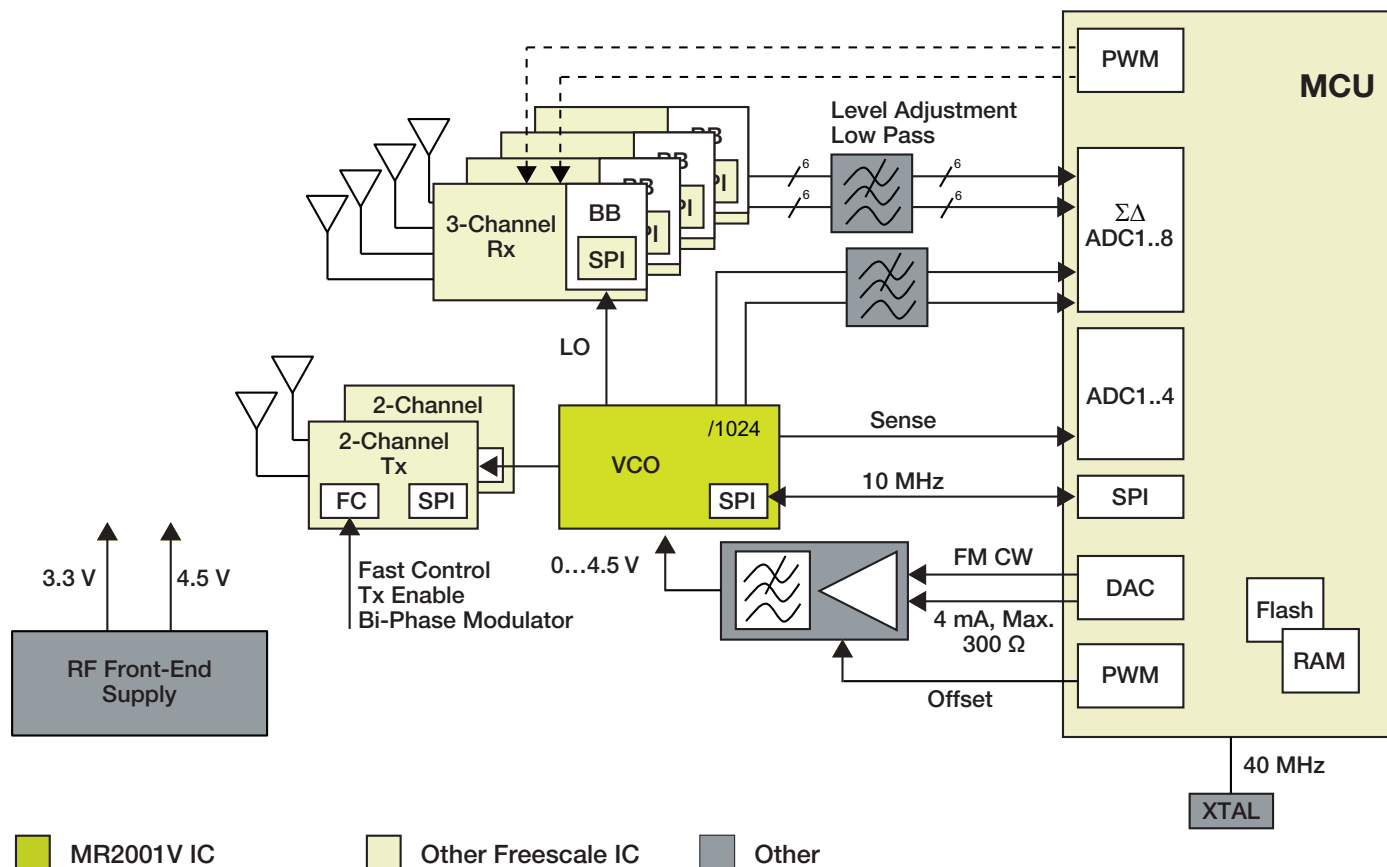

Figure 1. MR2001V simplified application diagram

\* This document contains certain information on a new product. Specifications and information herein are subject to change without notice.

**Table 1. Orderable part variations**

Part Number	Temperature (temp)	Package	Notes
MC33MR2001VVK	-40 °C to 125 °C	6.0 x 6.0 mm RCP (10 x 11 array) 0.5 mm pitch	(1)

Notes

- To order parts in Tape & Reel, add R2 to the suffix of the part number.

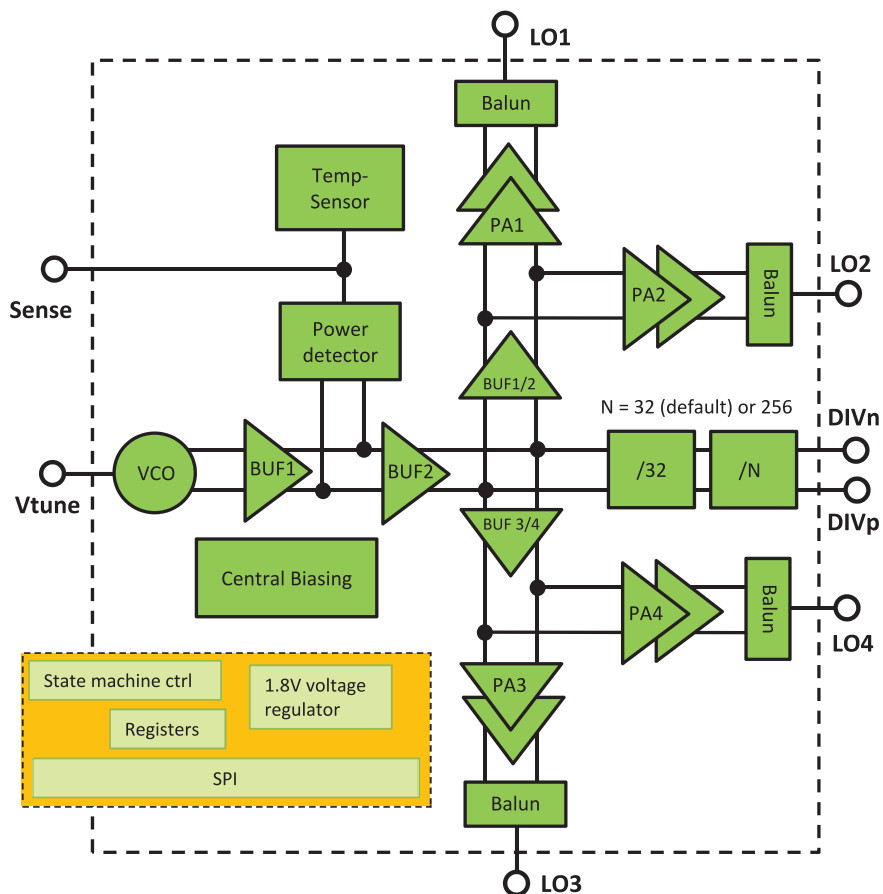

**Figure 2. MR2001V four-channel VCO block diagram**

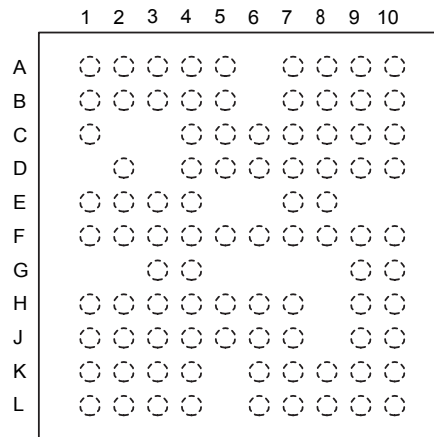

Figure 3. MR2001V pinout (ball) diagram

Table 2. MR2001V pin definitions

Ball location	Pin function
A1, B2, B3, B4, B10, C4, C8, C9, D4, E3, E4, F5, F6, G9, H7, H9, J2, J3, J9, K9, L3, L10	DC Ground
A2	Digital hard reset signal
A3	Differential Frequency Divider Output
A4	Differential Frequency Divider Output
A5, A7, B5, B7, C5, C7, D5, D6, D7, D8, D9, D10, E7, F1, F2, F3, F4, F7, F8, F9, F10, G4, H1, H2, H3, H4, H5, H6, J4, J6, K4, K6, L4, L6	RF Ground
A8, A9, A10, B8, B9, K1, K2, K3, L1, L2	3.3 V Power Supply
B1	1.8 V Regulator Output
C1	SPI enable (chip enable)
C10	Digital scan test
C6	38 GHz LO output channel 4
D2	SPI serial clock
E1	SPI MISO (master in, slave out)

Ball location	Pin function
E2	SPI MOSI (master out, slave in)
E8	38 GHz LO output channel 3
G10	Bandgap reference resistor (positive temperature slope)
G3	38 GHz LO output channel 1
H10	Bandgap reference resistor (negative temperature slope)
J1	Output to monitor internal bias nodes via ASCAN
J10	4.5 V Power Supply (only for the VCO core)
J5	38 GHz LO output channel 2
J7, K7, K8, L8, L9	3.3 V Power Supply
K10	Tuning Voltage
L7	Sensor output (temperature and power peak detector)

**Table 3. Key parameters**

Temp = -40 °C to +125 °C,  $f_{OUT}$  = 38 to 38.5 GHz,  $V_{CC4P0}$  = 4.5 V  $\pm$ 5.0%, and  $V_{CC3P3}$  = 3.3 V  $\pm$ 5.0%, unless otherwise noted.

Symbol	Parameter	Typ.	Unit	Notes
$V_{CC}$	Supply Voltage (VCO not included) • Nominal supply $\pm$ 5% variation	3.3	V	
$I_{CC1}$	Supply Current (all channels on, VCO not included) • All channels ON	170	mA	
$V_{CC\_VCO}$	VCO Supply Voltage	4.5	V	
$I_{CC\_VCO}$	VCO Supply Current	50	mA	
$P_{DIS}$	Power Consumption (all channels ON) • all channels ON, max. power	0.79	W	

**Frequency and # of channels**

KVCO	VCO tuning sensitivity ( $\Delta f/\Delta V$ ) at 76-77 GHz	2.5	GHz/V	
------	---	-----	-------	--

**Table 4. Revision history**

Revision	Date	Description of changes
1.0	6/2015	• Initial release
2.0	8/2016	• Added revision history table • Modified the target application lists • Corrected SPI access to temperature sensor and graph, and parameters • Corrected the parameters on assembly conditions

**How to Reach Us:****Home Page:**[NXP.com](http://www.nxp.com)**Web Support:**<http://www.nxp.com/support>

Information in this document is provided solely to enable system and software implementers to use NXP products. There are no expressed or implied copyright licenses granted hereunder to design or fabricate any integrated circuits based on the information in this document. NXP reserves the right to make changes without further notice to any products herein.

NXP makes no warranty, representation, or guarantee regarding the suitability of its products for any particular purpose, nor does NXP assume any liability arising out of the application or use of any product or circuit, and specifically disclaims any and all liability, including without limitation, consequential or incidental damages. "Typical" parameters that may be provided in NXP data sheets and/or specifications can and do vary in different applications, and actual performance may vary over time. All operating parameters, including "typicals," must be validated for each customer application by the customer's technical experts. NXP does not convey any license under its patent rights nor the rights of others. NXP sells products pursuant to standard terms and conditions of sale, which can be found at the following address:

<http://www.nxp.com/terms-of-use.html>.

NXP, the NXP logo, Freescale, the Freescale logo and SMARTMOS are trademarks of NXP B.V. All other product or service names are the property of their respective owners. All rights reserved.

© 2016 NXP B.V.

Document Number: MC33MR2001VSM

Rev. 2.0

8/2016

