

# TDA8007BHL

## Multiprotocol IC card interface

Rev. 9.1 — 18 June 2012

Product data sheet

## 1. General description

The TDA8007BHL is a cost-effective card interface for dual smart card readers. Controlled through a parallel bus, it meets all requirements of ISO 7816, GSM 11-11, EMV4.2 and EMV 2000. It is addressed on a non-multiplexed 8-bit databus, by means of address registers AD0, AD1, AD2 and AD3. TDA8007BHL/C3 can be also addressed through a multiplexed access. The integrated ISO UART and the time-out counters allow easy use even at high baud rates with no real time constraints. Due to its chip select, external input/output and interrupt features, it greatly simplifies the realization of a reader of any number of cards. It gives the cards and the reader a very high level of security, due to its special hardware against ESD, short-circuiting, power failure, etc. The integrated step-up converter allows operation within a supply voltage range of 2.7 V to 6 V.

TDA8007BHL/C4 supports only non multiplex access and TDA8007BHL/C3 support both non multiplexed and multiplexed access.

## 2. Features and benefits

- Control and communication through an 8-bit parallel interface, compatible with non-multiplexed memory access, TDA8007BHL/C3 can be also addressed through a multiplexed memory access
- Specific ISO UART with parallel access input/output for automatic convention processing, variable baud rate through frequency or division ratio programming, error management at character level for T = 0 and extra guard time register
- FIFO for 1 to 8 characters in reception mode
- Parity error counter in reception mode and in transmission mode with automatic re-transmission
- Dual VCC generation: 5 V  $\pm$  5 %, 65 mA (max.); 3 V  $\pm$  8 %, 50 mA (max.) or 1.8 V  $\pm$  10 %, 30 mA (max.); with controlled rise and fall times
- Dual cards clock generation (up to 10 MHz), with three times synchronous frequency doubling ( $f_{XTAL}$ ,  $\frac{1}{2}f_{XTAL}$ ,  $\frac{1}{4}f_{XTAL}$  and  $\frac{1}{8}f_{XTAL}$ )
- Cards clock stop (at high or low level) or 1.25 MHz (from internal oscillator) for cards Power-down mode
- Automatic activation and deactivation sequence through an independent sequencer
- Supports the asynchronous protocols T = 0 and T = 1 in accordance with: ISO 7816 and EMV4.2
- Versatile 24-bit time-out counter for Answer To Reset (ATR) and waiting times processing
- Specific Elementary Time Unit (ETU) counter for Block Guard Time (BGT): 22 in T = 1 and 16 in T = 0
- Minimum delay between two characters in reception mode:



- in Protocol T = 0: 11.8 ETU
- in Protocol T = 1: 10.8 ETU
- Supports synchronous cards
- Current limitations in the event of short-circuit (pins I/O1, I/O2, VCC1, VCC2, RST1 and RST2)
- Special circuitry for killing spikes during power-on/power-off
- Supply supervisor for power-on/power-off reset
- Step-up converter (supply voltage from 2.7 V to 6 V), doubler, tripler or follower according to V<sub>CC</sub> and V<sub>DD</sub>
- Additional input/output pin allowing use of the ISO UART for another analog interface (pin I/OAUX)
- Additional interrupt pin allowing detection of level toggling on an external signal (pin INTAUX)
- Fast and efficient swapping between the three cards due to separate buffering of parameters for each card
- Chip select input allowing use of several devices in parallel and memory space paging
- Enhanced ESD protections on card side (except C4x, C8x): 6 kV (min.)
- Software library for easy integration within the application
- Power-down mode for reducing current consumption when no activity.

### 3. Applications

- Multiple smart card readers for multiprocessor applications (EMV banking, digital pay TV and access control, etc.).

### 4. Quick reference data

**Table 1. Quick reference data**

$V_{DD} = 3.3\text{ V}$ ;  $f_{XTAL} = 10\text{ MHz}$ ;  $GND = 0\text{ V}$ ;  $T_{amb} = 25\text{ °C}$ ; unless otherwise specified.

Symbol	Parameter	Conditions	Min	Typ	Max	Unit
V <sub>DD</sub>	supply voltage		2.7	-	6.0	V
V <sub>DDA</sub>	analog supply voltage	step-up converter	V <sub>DD</sub>	-	6.0	V
I <sub>DD(pd)</sub>	supply current in power-down mode	cards inactive; $f_{XTAL} = 0\text{ Hz}$	-	-	350	μA
		cards active; V <sub>CC</sub> = 5 V; $f_{CLK} = 0\text{ Hz}$ ; $f_{XTAL} = 0\text{ Hz}$	-	-	3	mA
I <sub>DD(sm)</sub>	supply current in sleep mode	cards active; $f_{CLK} = 0\text{ Hz}$	-	-	5.5	mA
I <sub>DD(oper)</sub>	supply current in operating mode	I <sub>CC1</sub> = 65 mA; I <sub>CC2</sub> = 15 mA; $f_{XTAL} = 20\text{ MHz}$ ; $f_{CLK} = 10\text{ MHz}$ ; V <sub>DD</sub> = 2.7 V	-	-	315	mA

**Table 1. Quick reference data ...continued**

$V_{DD} = 3.3\text{ V}$ ;  $f_{XTAL} = 10\text{ MHz}$ ;  $GND = 0\text{ V}$ ;  $T_{amb} = 25\text{ °C}$ ; unless otherwise specified.

Symbol	Parameter	Conditions	Min	Typ	Max	Unit
$V_{CC}$	card supply output voltage	5 V card				
		including static loads	4.75	5.0	5.25	V
		with 40 nC dynamic loads on 200 nF capacitor	4.6	-	5.4	V
		3 V card				
		including static loads	2.78	-	3.22	V
		with 24 nC dynamic loads on 200 nF capacitor	2.75	-	3.25	V
		1.8 V card				
		including static loads	1.65	-	1.95	V
		with 12 nC dynamic loads on 200 nF capacitor	1.62	-	1.98	V
$I_{CC}$	card supply output current	5 V card; operating	-	-	65	mA
		3 V card; operating	-	-	50	mA
		1.8 V card; operating	-	-	30	mA
		overload detection	-	100	-	mA
$I_{CC1} + I_{CC2}$	sum of both card supply output currents	operating; 5 and 3 V cards	-	-	80	mA
SR	slew rate on $V_{CC}$ (rise and fall)	$C_{L(max)} = 300\text{ nF}$	0.05	0.16	0.22	V/ $\mu\text{s}$
$t_{deact}$	deactivation cycle duration		-	-	150	$\mu\text{s}$
$t_{act}$	activation cycle duration		-	-	225	$\mu\text{s}$
$f_{XTAL}$	crystal frequency		4	-	20	MHz
$f_{ext}$	external frequency	applied to pin XTAL1	0	-	20	MHz
$T_{amb}$	ambient temperature		-40	-	+85	$^{\circ}\text{C}$

## 5. Ordering information

**Table 2. Ordering information**

Type number	Package		Version
	Name	Description	
TDA8007BHL/C3	LQFP48	plastic low profile quad flat package; 48 leads; body 7 × 7 × 1.4 mm	SOT313-2
TDA8007BHL/C4	LQFP48	plastic low profile quad flat package; 48 leads; body 7 × 7 × 1.4 mm	SOT313-2

### 6. Block diagram

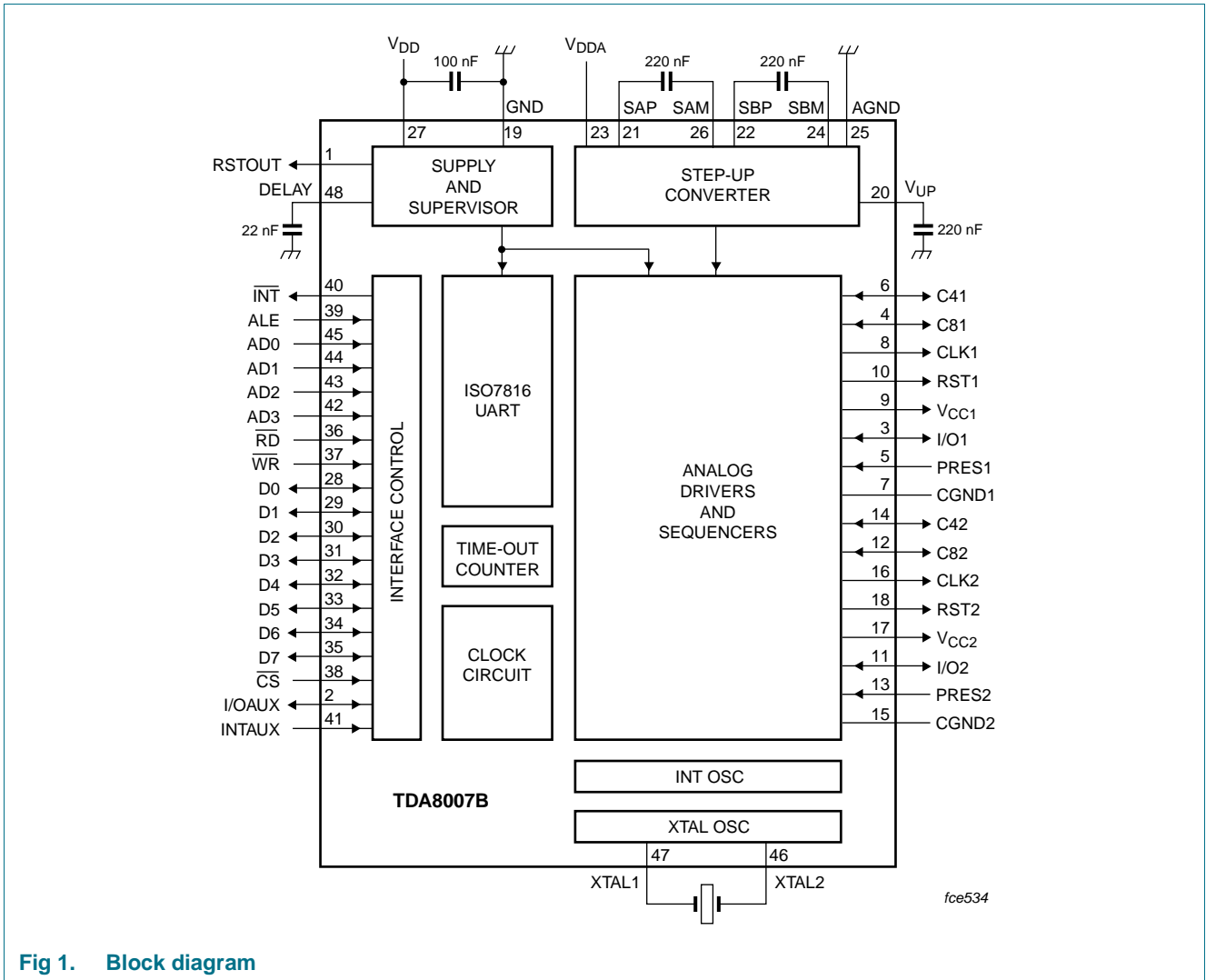

Fig 1. Block diagram

## 7. Pinning information

### 7.1 Pinning

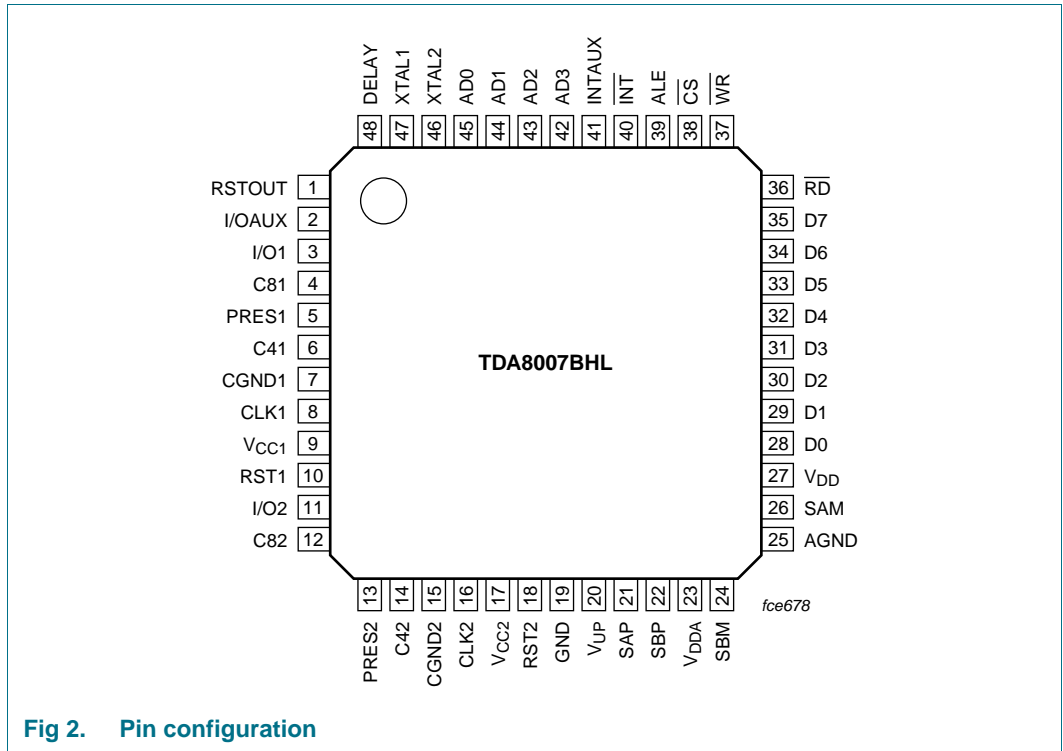

Fig 2. Pin configuration

### 7.2 Pin description

Table 3. Pin description

Symbol	Pin	Description
RSTOUT	1	PMOS open-drain output for resetting external devices
I/OAUX	2	input or output for an I/O line from an auxiliary smart card interface
I/O1	3	input or output for the data line to/from card 1 (ISO C7 contact)
C81	4	auxiliary I/O for ISO C8 contact (synchronous cards, for instance) for card 1
PRES1	5	card 1 presence contact input (active high)
C41	6	auxiliary I/O for ISO C4 contact (synchronous cards, for instance) for card 1
CGND1	7	ground for card 1; must be connected to GND
CLK1	8	clock output to card 1 (ISO C3 contact)
V <sub>CC1</sub>	9	card 1 supply output voltage (ISO C1 contact)
RST1	10	card 1 reset output (ISO C2 contact)
I/O2	11	input or output for the data line to/from card 2 (ISO C7 contact)

Table 3. Pin description ...continued

Symbol	Pin	Description
C82	12	auxiliary I/O for ISO C8 contact (synchronous cards, for instance) for card 2
PRES2	13	card 2 presence contact input (active high)
C42	14	auxiliary I/O for ISO C4 contact (synchronous cards, for instance) for card 2
CGND2	15	ground for card 2; must be connected to GND
CLK2	16	clock output to card 2 (ISO C3 contact)
V <sub>CC2</sub>	17	card 2 supply output voltage (ISO C1 contact)
RST2	18	card 2 reset output (ISO C2 contact)
GND	19	ground
V <sub>UP</sub>	20	connection for the step-up converter capacitor; connect a low ESR capacitor of 220 nF to AGND
SAP	21	contact 1 for the step-up converter; connect a low ESR capacitor of 220 nF between pins SAP and SAM
SBP	22	contact 3 for the step-up converter; connect a low ESR capacitor of 220 nF between pins SBP and SBM
V <sub>DDA</sub>	23	positive analog supply voltage for the step-up converter; may be higher than V <sub>DD</sub> ; decouple with a good quality capacitor to GND
SBM	24	contact 4 for the step-up converter; connect a low ESR capacitor of 220 nF between pins SBP and SBM
AGND	25	analog ground for the step-up converter
SAM	26	contact 2 for the step-up converter; connect a low ESR capacitor of 220 nF between pins SAP and SAM
V <sub>DD</sub>	27	positive supply voltage; decouple with a good quality capacitor to GND
D0 to D7	28, 29, 30, 31, 32, 33, 34, 35	input/output of data 0-7; TDA8007BHL/C3 in case of multiplexed configuration: address 0-7
$\overline{\text{RD}}$	36	read or write selection input; high for read, low for write
$\overline{\text{WR}}$	37	enable pin; same behavior as CS\ (active low)
$\overline{\text{CS}}$	38	chip select input (active low)
ALE	39	TDA8007BHL/C4: Not connected; TDA8007BHL/C3: address latch enable input in case of multiplexed configuration, connect to V <sub>DD</sub> in non-multiplexed configuration
$\overline{\text{INT}}$	40	NMOS interrupt output (active low)
INTAUX	41	auxiliary interrupt input
AD3	42	register selection address 3 input
AD2	43	register selection address 2 input
AD1	44	register selection address 1 input

Table 3. Pin description ...continued

Symbol	Pin	Description
AD0	45	register selection address 0 input
XTAL2	46	connection for an external crystal
XTAL1	47	connection for an external crystal or input for an external clock signal
DELAY	48	connection for an external delay capacitor

## 8. Functional description

**Remark:** Throughout this document, it is assumed that the reader is familiar with ISO7816 terminology.

### 8.1 Interface control

The TDA8007BHL/C3 is sensitive to ESD in functional mode. This sensitivity is seen on pin ALE: an electrostatic discharge causes an edge on this pin and changes its mode of communication. When the mode of communication is the multiplexed mode, this has no impact. But when the mode used is the non-multiplexed mode, the ESD may change the mode to multiplexed mode, which is irreversible without power-off/power-on.

The TDA8007BHL/C4 is an evolution of the C3 version in which the communication mode is set to non-multiplexed and can not be changed.

#### 8.1.1 Non-Multiplexed configuration

The TDA8007BHL/C4 is only in the non-multiplexed configuration ([Figure 3](#)), where the TDA8007BHL/C3 offers a multiplexed configuration in addition to a non-multiplexed configuration. The configuration can be chosen through the ALE-pin. If pin ALE is tied to  $V_{DD}$  or ground, the TDA8007BHL/C3 will be in the non-multiplexed configuration.

The TDA8007BHL can be controlled via an 12-bit parallel bus (bits D0 to D7 and bits A0 to A3). The address bits are determined by means of pins AD0 to AD3. The read or write control signal is on pin RD and a data write or read active low enable signal is on pin WR. Signals CS and WR play the same role.

In read operations (see [Figure 4](#)) with signal RD = high, the data corresponding to the chosen address is available on the bus when both signals CS and WR are low.

In write operations (see [Figure 5](#) and [6](#)) with signal RD = low, the data present on the bus is written when signals CS and WR are low.

In both configurations, the TDA8007BHL/C4 is selected only when signal CS = low.

Signal  $\overline{\text{INT}}$  is an active low interrupt signal.

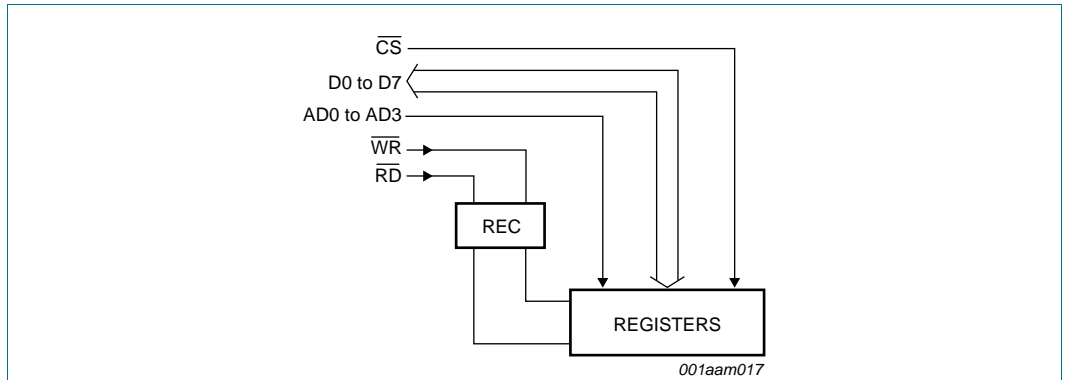

Fig 3. Non-multiplexed bus configuration

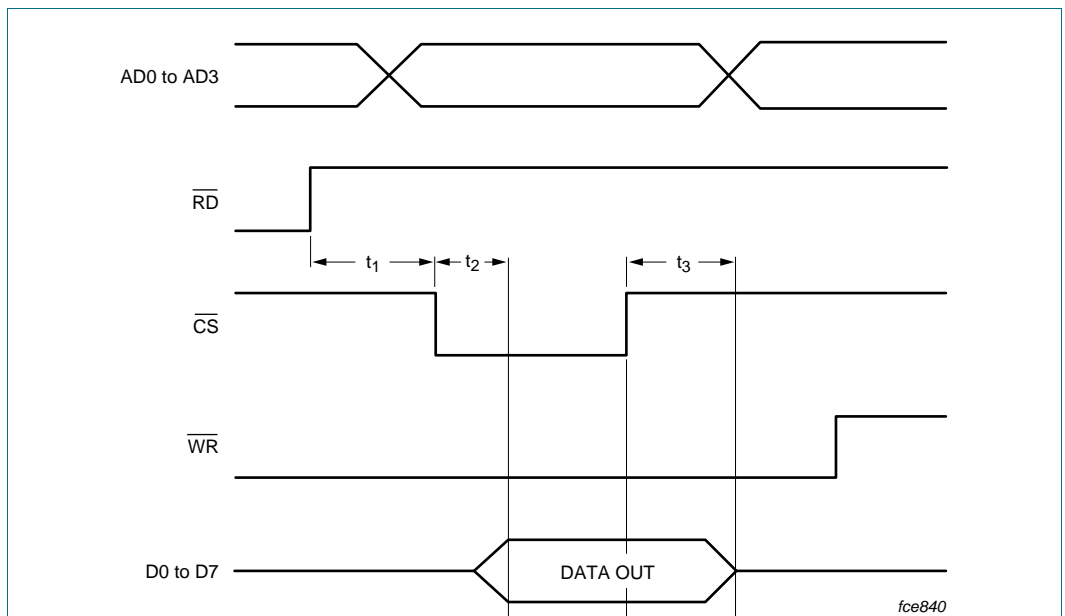

Fig 4. Control with non-multiplex bus (read)



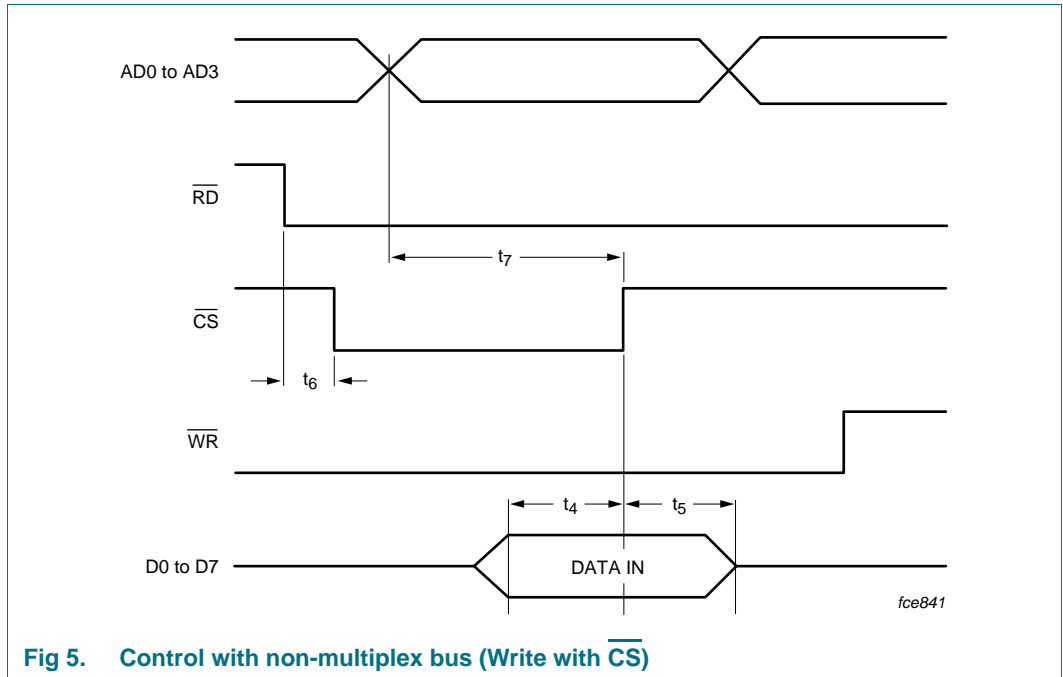

Fig 5. Control with non-multiplex bus (Write with  $\overline{CS}$ )

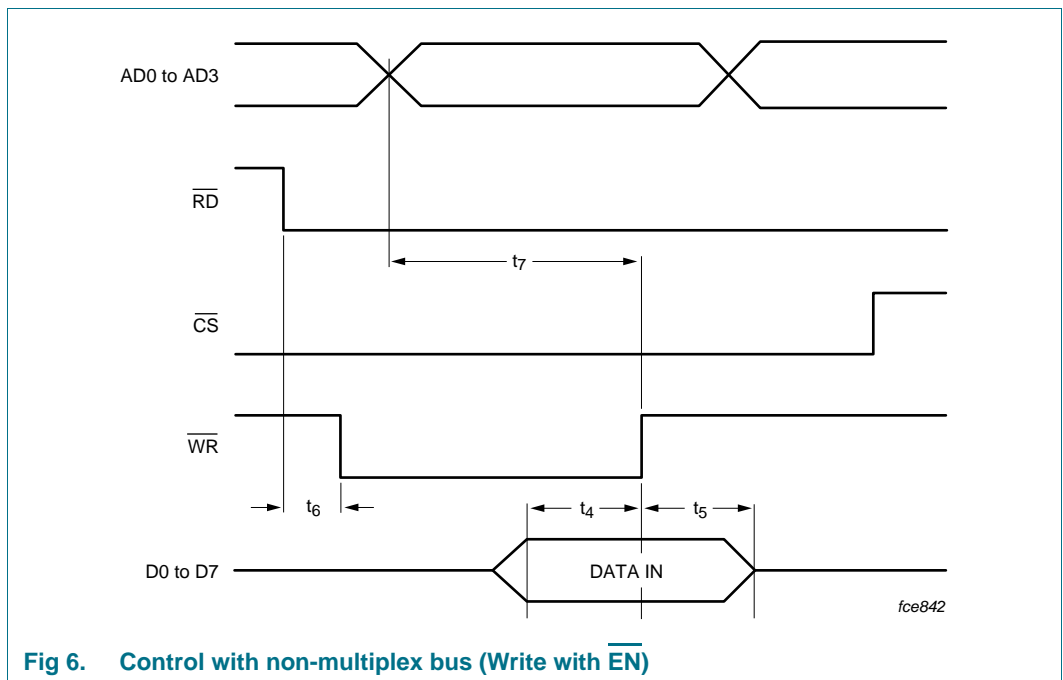

Fig 6. Control with non-multiplex bus (Write with  $\overline{EN}$ )

### 8.1.2 Multiplexed configuration

The TDA8007BHL/C3 offers a multiplexed configuration in addition to a non-multiplexed configuration.

The TDA8007BHL/C4 does not offer the multiplexed configuration.

If a microcontroller with a multiplexed address and data bus (such as 80C51) is used, then pins D0 to D7 may be directly connected to port P0 to P7, see [Figure 7](#). Automatic switching to the multiplexed bus configuration occurs only for TDA8007BHL/C3, if a rising edge is detected on signal ALE.

In this event, pins AD0 to AD3 play no role and may be tied to VDD or ground.

When signal  $\overline{CS}$  = low, the demultiplexing of address and data is performed internally using signal ALE, a low pulse on pin  $\overline{RD}$  allows the selected register to be read, a LOW pulse on pin  $\overline{WR}$  allows the selected register to be written to, see [Figure 8](#). Using a 80C51 microcontroller, the TDA8007BHL/C3 is simply controlled with MOVX instructions.

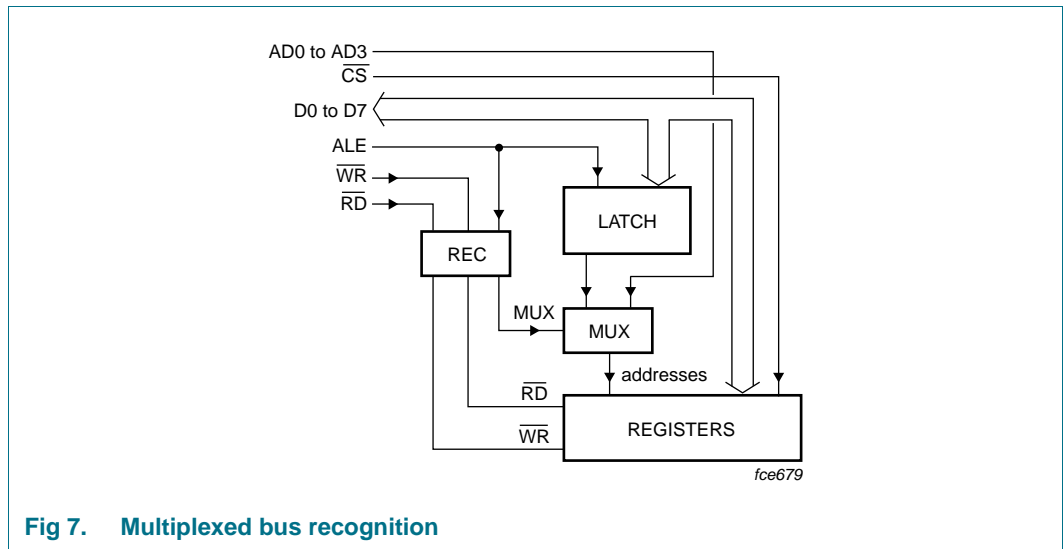

Fig 7. Multiplexed bus recognition

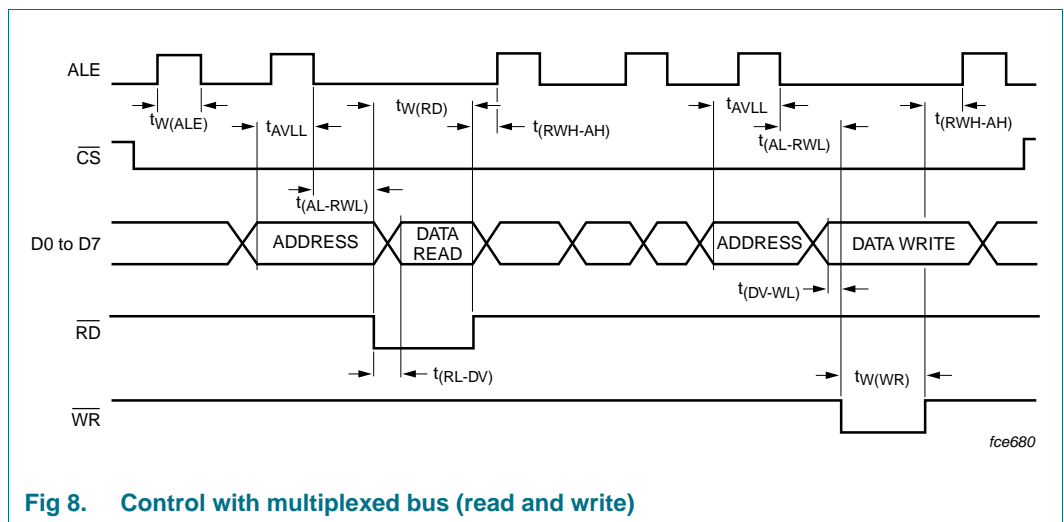

Fig 8. Control with multiplexed bus (read and write)

## 8.2 Control registers

The TDA8007BHL has two complete analog interfaces which can drive cards 1 and 2. The data to and from these two cards shares the same ISO UART. The data to and from a third card (card 3), externally interfaced (with a TDA8020 or TDA8004 for example), may also share the same ISO UART.

Cards 1, 2 and 3 have dedicated registers for setting the parameters of the ISO UART (see [Figure 9](#)).

- Programmable Divider Register (PDR)
- Guard Time Register (GTR)
- UART Configuration register 1 (UCR1)
- UART Configuration Register 2 (UCR2)
- Clock Configuration Register (CCR)

Cards 1 and 2 also have dedicated registers for controlling their power and clock configuration. The Power Control Register (PCR) for card 3 is controlled externally. Register PCR is also used for writing or reading on the auxiliary card contacts C4 and C8.

Card 1, 2 or 3 can be selected via the Card Select Register (CSR). When one card is selected, the corresponding parameters are used by the ISO UART. Register CSR also contains one bit for resetting the ISO UART (bit RIU = 0). This bit is reset after power-on and must be set to logic 1 before starting with any one of the cards. It may be reset by software when necessary.

When the specific parameters of the cards have been programmed, the UART may be used with the following registers:

- UART Receive Register (URR)
- UART Transmit Register (UTR)
- UART Status Register (USR)
- Mixed Status Register (MSR).

In reception mode, a FIFO of 1 to 8 characters may be used and is configured with the FIFO Control Register (FCR). This register is also used for the automatic re-transmission of Not Acknowledged (NAK) characters in transmission mode.

The Hardware Status Register (HSR) gives the status of the supply voltage, of the hardware protections and of the card movements.

Registers HSR and USR give interrupts on pin  $\overline{\text{INT}}$  when some of their bits have been changed.

Register MSR does not give interrupts and may be used in the polling mode for some operations; for this use, some of the interrupt sources within the registers USR and HSR may be masked.

A 24-bit time-out counter may be started to give an interrupt after a number of ETU programmed into the Time-Out Registers TOR1, TOR2 and TOR3. This will help the microcontroller in processing different real-time tasks (ATR, WWT, BWT, etc.). This counter is configured with a Time-Out counter Configuration (TOC) register. It may be used as a 24-bit counter or as a 16-bit plus 8-bit counter. Each counter can be set to start counting once data has been written, or on detection of a START bit on the I/O, or as auto-reload.

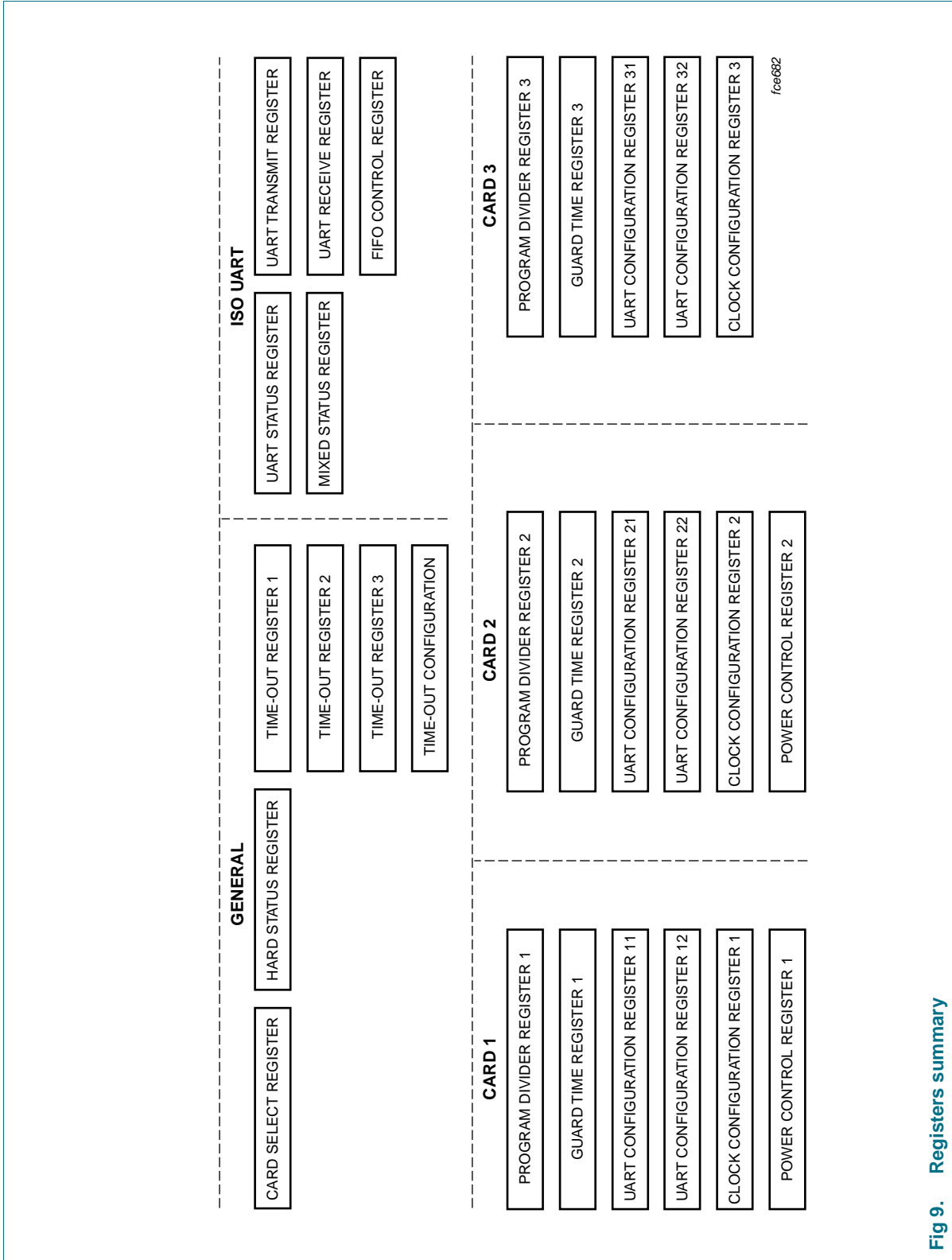

Fig 9. Registers summary

## 8.2.1 General registers

### 8.2.1.1 Card select register

The Card Select Register (CSR) is used for selecting the card on which the UART will act, and also to reset the ISO UART.

**Table 4. Register CSR (address 00h; write and read)**<sup>[1]</sup>

7	6	5	4	3	2	1	0
CS7	CS6	CS5	CS4	RIU	SC3	SC2	SC1

[1] Register value at reset: all significant bits are cleared after reset, except bits CS7 to CS4 which are set to their default value

**Table 5. Register CSR (address 00h; write and read)**<sup>[1]</sup>

Bit	Symbol	Description
7	CS7	<b>IC identifier:</b> default value for identification the IC
6	CS6	0010 = TDA8007BHL/C2
5	CS5	0011 = TDA8007BHL/C3 or TDA8007BHL/C4
4	CS4	
3	RIU	<b>reset ISO UART:</b> When reset, this bit resets a large part of the UART registers to their initial value. Bit RIU must be reset before any activation; logic 0 for at least 10 ns duration. Bit RIU must be set to logic 1 by software before any action on the UART can take place.
2	SC3	<b>select card 3:</b> If bit SC3 = 1, then card 3 is selected.
1	SC2	<b>select card 2:</b> If bit SC2 = 1, then card 2 is selected.
0	SC1	<b>select card 1:</b> If bit SC1 = 1, then card 1 is selected.

[1] Bits SC1, SC2 and SC3 must be set at one at a time. After reset no card is selected by default

### 8.2.1.2 Hardware status register

The Hardware Status Register (HSR) gives the status of the chip after a hardware problem has been detected.

**Table 6. Register HSR (address 0Fh; read only)**<sup>[1]</sup>

7	6	5	4	3	2	1	0
HS7	PRTL2	PRTL1	SUPL	PRL2	PRL1	INTAUXL	PTL

[1] Register value at reset: all significant bits are cleared after reset, except bit SUPL which is set within pulse RSTOUT.

**Table 7. Description of HSR bits**

Bit	Symbol	Description
7	HS7	not used
6	PRTL2	<b>protection 2:</b> Bit PRTL2 = 1 when a fault has been detected on card reader 2. Bit PRTL 2 is the OR-function of the protection on pin V <sub>CC2</sub> and pin RST2.
5	PRTL1	<b>protection 1:</b> Bit PRTL1 = 1 when a fault has been detected on card reader 1. Bit PRTL 1 is the OR-function of the protection on pin V <sub>CC1</sub> and pin RST1.
4	SUPL	<b>supervisor latch.</b> Bit SUPL = 1 when the supervisor has been activated.
3	PRL2	<b>presence latch 2:</b> Bit PRL2 = 1 when a level change has occurred on pin PRES2.
2	PRL1	<b>presence latch 1:</b> Bit PRL1 = 1 when a level change has occurred on pin PRES1.
1	INTAUXL	<b>auxiliary interrupt change:</b> Bit INTAUXL = 1 if the level on pin INTAUX has been changed.
0	PTL	<b>overheating:</b> Bit PTL = 1 if overheating has occurred.

When at least one of the bits PRTL2, PRTL1, PRL2, PRL1 or PTL is high, then  $\overline{\text{INT}}$  is low. The bits having caused the interrupt are cleared when register HSR has been read-out. The same occurs with INTAUXL, if not disabled.

In case of an emergency deactivation (by bits PRTL2, PRTL1, SUPL, PRL2, PRL1 or PTL), bit START (bit 0 in the PCR) is automatically reset by hardware.

At power-on, or after a supply voltage drop-out, bit SUPL is set and pin  $\overline{\text{INT}}$  = low. Pin  $\overline{\text{INT}}$  will return to high level at the end of the alarm pulse RSTOUT (see [Figure 3](#)).

Bit SUPL will be reset only after a status register read-out outside the alarm pulse.

A minimum time of 2  $\mu\text{s}$  is needed between two successive read operations of register HSR, as well as between reading of register HSR and activation (write in register PCR).

### 8.2.1.3 Time-out registers

The three Time-Out Registers (TOR1, TOR2 and TOR3) form a programmable 24-bit ETU counter, or two independent counters (one 16-bit and one 8-bit). The value to load in registers TOR1, TOR2 and TOR3 is the number of ETU to count. The time-out counters may only be used when a card is active with a running clock.

**Table 8. Register TOR1 (address 09H; write only)<sup>[1]</sup>**

7	6	5	4	3	2	1	0
TOL7	TOL6	TOL5	TOL4	TOL3	TOL2	TOL1	TOL0

[1] Register value at reset: all bits are cleared after reset.

**Table 9. Register TOR2 (address 0AH; write only)<sup>[1]</sup>**

7	6	5	4	3	2	1	0
TOL15	TOL14	TOL13	TOL12	TOL11	TOL10	TOL9	TOL8

[1] Register value at reset: all bits are cleared after reset.

**Table 10. Register TOR3 (address 0Bh; write only)**<sup>[1]</sup>

7	6	5	4	3	2	1	0
TOL23	TOL22	TOL21	TOL20	TOL19	TOL18	TOL17	TOL16

[1] Register value at reset: all bits are cleared after reset.

#### 8.2.1.4 Time-out configuration register

The Time-Out Configuration (TOC) register is used for setting different configurations of the time-out counter as given in Table 11; all other configurations are undefined.

**Table 11. Register TOC (address 0Bh; read and write)**<sup>[1]</sup>

7	6	5	4	3	2	1	0
TOC7	TOC6	TOC5	TOC4	TOC3	TOC2	TOC1	TOC0

[1] Register value at reset: all bits are cleared after reset.

**Table 12. Card registers (address 00h to F5h)**

Register	Description
00H	All counters are stopped.
05H	Counters 2 and 3 are stopped; counter 1 continues to operate in auto-reload mode.
61H	Counter 1 is stopped, and counters 3 and 2 form a 16-bit counter. Counting the value stored in registers TOR3 and TOR2 is started after 61H is written in register TOC. An interrupt is given, and bit TO3 is set within register USR when the terminal count is reached. The counter is stopped by writing 00H in register TOC, and should be stopped before reloading new values in registers TOR2 and TOR3.
65H	Counter 1 is an 8-bit auto-reload counter, and counters 3 and 2 form a 16-bit counter. Counter 1 starts counting the content of register TOR1 on the first START bit (reception or transmission) detected on pin I/O after 65H is written in register TOC. When counter 1 reaches its terminal count, an interrupt is given, bit TO1 in register USR is set, and the counter automatically restarts the same count until it is stopped. It is not allowed to change the content of register TOR1 during a count. Counters 3 and 2 are wired as a single 16-bit counter and start counting the value in registers TOR3 and TOR2 when 65H is written in register TOC. When the counter reaches its terminal count, an interrupt is given and bit TO3 is set within register USR. Both counters are stopped when 00H is written in register TOC. Counters 3 and 2 shall be stopped by writing 05H in register TOC before reloading new values in registers TOR2 and TOR3.
68H	Counters 3, 2 and 1 are wired as a single 24-bit counter. Counting the value stored in registers TOR3, TOR2 and TOR1 is started after 68H is written in register TOC. The counter is stopped by writing 00H in register TOC. It is not allowed to change the content of registers TOR3, TOR2 and TOR1 within a count.
71H	Counter 1 is stopped, and counters 3 and 2 form a 16-bit counter. Counting the value stored in registers TOR3 and TOR2 and is started on the first START bit detected on pin I/O (reception or transmission) after the value has been written, and then on each subsequent START bit. It is possible to change the content of registers TOR3 and TOR2 during a count; the current count will not be affected and the new count value will be taken into account at the next START bit. The counter is stopped by writing 00H in register TOC. In this configuration, registers TOR3, TOR2 and TOR1 must not be all zero.

Table 12. Card registers (address 00h to F5h ...continued)

Register	Description
75H	Counter 1 is an 8-bit auto-reload counter, and counters 3 and 2 form a 16-bit counter. Counter 1 starts counting the content of register TOR1 on the first START bit (reception or transmission) detected on pin I/O after 75H is written in register TOC. When counter 1 reaches its terminal count, an interrupt is given, bit TO1 in register USR is set, and the counter automatically restarts the same count until it is stopped. Changing the content of register TOR1 during a count is not allowed. Counting the value stored in registers TOR3 and TOR2 is started on the first START bit detected on pin I/O (reception or transmission) after the value has been written, and then on each subsequent START bit. It is possible to change the content of registers TOR3 and TOR2 during a count; the current count will not be affected and the new count value will be taken into account at the next START bit. The counter is stopped by writing 00H in register TOC. In this configuration, registers TOR3, TOR2 and TOR1 must not be all zero.
7CH	Counters 3, 2 and 1 are wired as a single 24-bit counter. Counting the value stored in registers TOR3, TOR2 and TOR1 is started on the first START bit detected on pin I/O (reception or transmission) after the value has been written, and then on each subsequent START bit. It is possible to change the content of registers TOR3, TOR2 and TOR1 during a count; the current count will not be affected and the new count value will be taken into account at the next START bit. The counter is stopped by writing 00H in register TOC. In this configuration, registers TOR3, TOR2 and TOR1 must not be all zero.
85H	Same as value 05H, except that all the counters will be stopped at the end of the 12th ETU following the first received START bit detected after 85H has been written in register TOC.
E5H	Same configuration as value 65H, except that counter 1 will be stopped at the end of the 12th ETU following the first START bit detected after E5H has been written in register TOC.
F1H	Same configuration as value 71H, except that the 16-bit counter will be stopped at the end of the 12th ETU following the first START bit detected after F1H has been written in register TOC.
F5H	Same configuration as value 75H, except the two counters will be stopped at the end of the 12th ETU following the first START bit detected after F5H has been written in register TOC.

The time-out counter is very useful for processing the clock counting during ATR, the Work Waiting Time (WWT) or the waiting times defined in protocol T = 1. It should be noted that the 200 and  $n_{\max}$  clock counter ( $n_{\max} = 368$  for TDA8007BHL/C4) used during ATR is done by hardware when the start session is set, specific hardware controls the functionality of BGT in T = 1 and T = 0 protocols and a specific register is available for processing the extra guard time.

Writing to register TOC is not allowed as long as the card is not activated with a running clock.

Before restarting the 16-bit counter (counters 3 and 2) by writing 61H, 65H, 71H, 75H, F1H or F5H in the TOC; or the 24-bit counter (counters 3, 2 and 1) by writing 68H in the TOC; it is mandatory to stop them by writing 00h in the TOC.

Detailed examples of how to use these specific timers can be found in application note "AN01054".



## 8.2.2 ISO UART registers

### 8.2.2.1 UART Transmit Register (UTR)

Table 13. Register UTR (address 0DH; write only)<sup>[1]</sup>

7	6	5	4	3	2	1	0
UT7	UT6	UT5	UT4	UT3	UT2	UT1	UT0

[1] Register value at reset: all bits are cleared after reset.

When the microcontroller wants to transmit a character to the selected card, it writes the data in direct convention in the UART transmit register. The transmission:

- Starts at the end of writing (on the rising edge of signal WR) if the previous character has been transmitted and if the extra guard time has expired
- Starts at the end of the extra guard time if this one has not expired
- Does not start if the transmission of the previous character is not completed
- With a synchronous card (bit SAN within register UCR2 is set), only signal D0 is relevant and is copied on pin I/O of the selected card.

### 8.2.2.2 UART Receive Register (URR)

Table 14. Register URR (address 0DH; read only)<sup>[1]</sup>

7	6	5	4	3	2	1	0
UR7	UR6	UR5	UR4	UR3	UR2	UR1	UR0

[1] Register value at reset: all bits are cleared after reset.

When the microcontroller wants to read data from the card, it reads it from the UART Receive Register (URR) in direct convention:

- With a synchronous card, only D0 is relevant and is a copy of the state of the selected card I/O
- When needed, this register may be tied to a FIFO whose length 'n' is programmable between 1 and 8; if n > 1, then no interrupt is given until the FIFO is full and the controller may empty the FIFO when required
- With a parity error:
  - a. \_ In protocol T = 0; the received byte is not stored in the FIFO and the error counter is incremented. The error counter is programmable between 1 and 8. When the programmed number is reached, then the bit PE is set in the status register USR and INT0 falls low. The error counter must be reprogrammed to the desired value after its count has been reached
  - b. \_ In protocol T = 1; the character is loaded in the FIFO and the bit PE is set whatever the programmed value in the parity error counter
- When the FIFO is full, then the bit RBF in the status register USR is set. This bit is reset when at least one character has been read from URR
- When the FIFO is empty, then the bit FE is set in the status register USR as long as no character has been received.

8.2.2.3 Mixed Status Register (MSR)

The MSR relates the status of pin INTAUX, the cards presence contacts PRES1 and PRES2, the BGT counter, the FIFO empty indication and the transmit or receive ready indicator TBE/RBF. It also gives useful indications when switching the clock to or from  $\frac{1}{2} f_{int}$  and when driving the TDA8007BHL/C4 with fast controllers.

No bits within register MSR act upon signal  $\overline{INT}$ .

Table 15. Register MSR (address 0Ch; read only)<sup>[1]</sup>

7	6	5	4	3	2	1	0
CLKSW	FE	BGT	CRED	PR2	PR1	INTAUX	TBE/RBF

[1] Register value at reset: bits TBE/RBF, BGT and CLKSW are cleared after reset; bits FE and CRED are set after reset.

Table 16. Description of MSR bits

Bit	Symbol	Description
7	CLKSW	<b>clock switch:</b> Bit CLKSW is set when the TDA8007BHL/C4 has performed a required clock switch from $\frac{1}{n}f_{XTAL}$ to $\frac{1}{2}f_{int}$ , and is reset when the TDA8007BHL/C4 has performed a required clock switch from $\frac{1}{2}f_{int}$ to $\frac{1}{n}f_{XTAL}$ . The application must wait until this bit is set or reset before sending a new command to the card. This bit is reset at power-on.
6	FE	<b>FIFO Empty:</b> Bit FE is set when the reception FIFO is empty. It is reset when at least one character has been loaded in the FIFO.
5	BGT	<b>block guard time:</b> In protocol T = 1, bit BGT is linked with a 22-ETU counter which is started at every START bit on pin I/O. Bit BGT is set if the count is finished before the next START bit. This helps to verify that the card has not answered before 22 ETU after the last transmitted character, or that the reader is not transmitting a character before 22 ETU after the last received character.  In protocol T = 0, bit BGT is linked with a 16-ETU counter which is started at every START bit on pin I/O. Bit BGT is set if the count is finished before the next START bit. This helps to verify that the reader is not transmitting a character before 16 ETU after the last received character.
4	CRED	<b>control ready:</b> It is advised bit CRED is used for driving the TDA8007BHL/C4 with high speed controllers. Before writing in registers TOC or UTR, or reading from register URR, check if bit CRED is set. If reset, it means that the writing or reading operation will not be correct because the controller is acting faster than the required time for this operation:
3	PR2	<b>card 2 present:</b> Bit PR2 = 1 when card 2 is present.

Table 16. Description of MSR bits ...continued

Bit	Symbol	Description
2	PR1	<b>card 1 present.</b> Bit PR1 = 1 when card 1 is present.
1	INTAUX	<b>auxiliary interrupt.</b> Bit INTAUX is set when pin INTAUX = high and it is reset when pin INTAUX = low.
0	TBE/RBF	<b>transmit buffer empty/receive buffer full.</b> Bit TBE/RBF = 1 when: <ul style="list-style-type: none"> <li>- changing from reception mode to transmission mode</li> <li>- the reception FIFO is full.</li> <li>- a character has been transmitted by the UART</li> </ul> Bit TBE/RBF = 0 after power-on or after one of the following: <ul style="list-style-type: none"> <li>- when bit RIU is reset</li> <li>- when a character has been written to register UTR</li> <li>- when at least one character has been read in the FIFO</li> <li>- when changing from transmission mode to reception mode.</li> </ul>

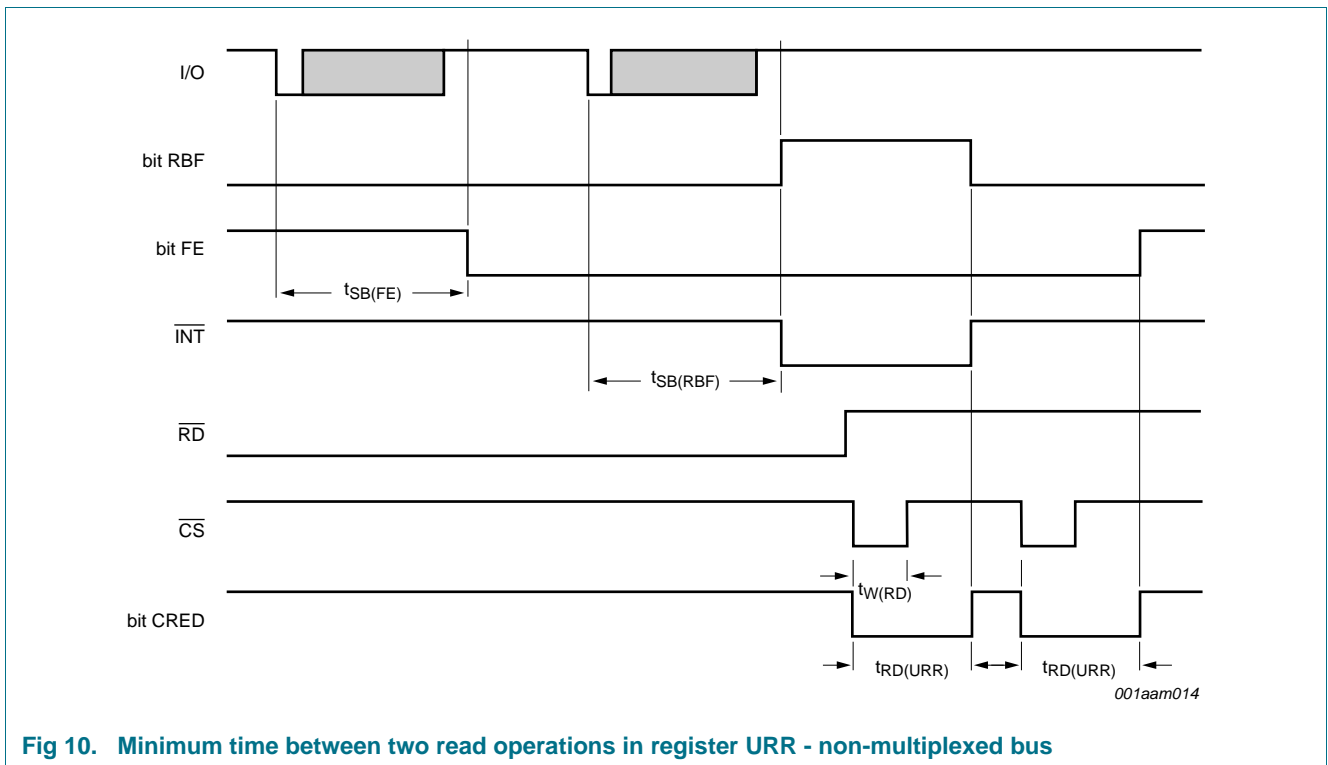

Fig 10. Minimum time between two read operations in register URR - non-multiplexed bus

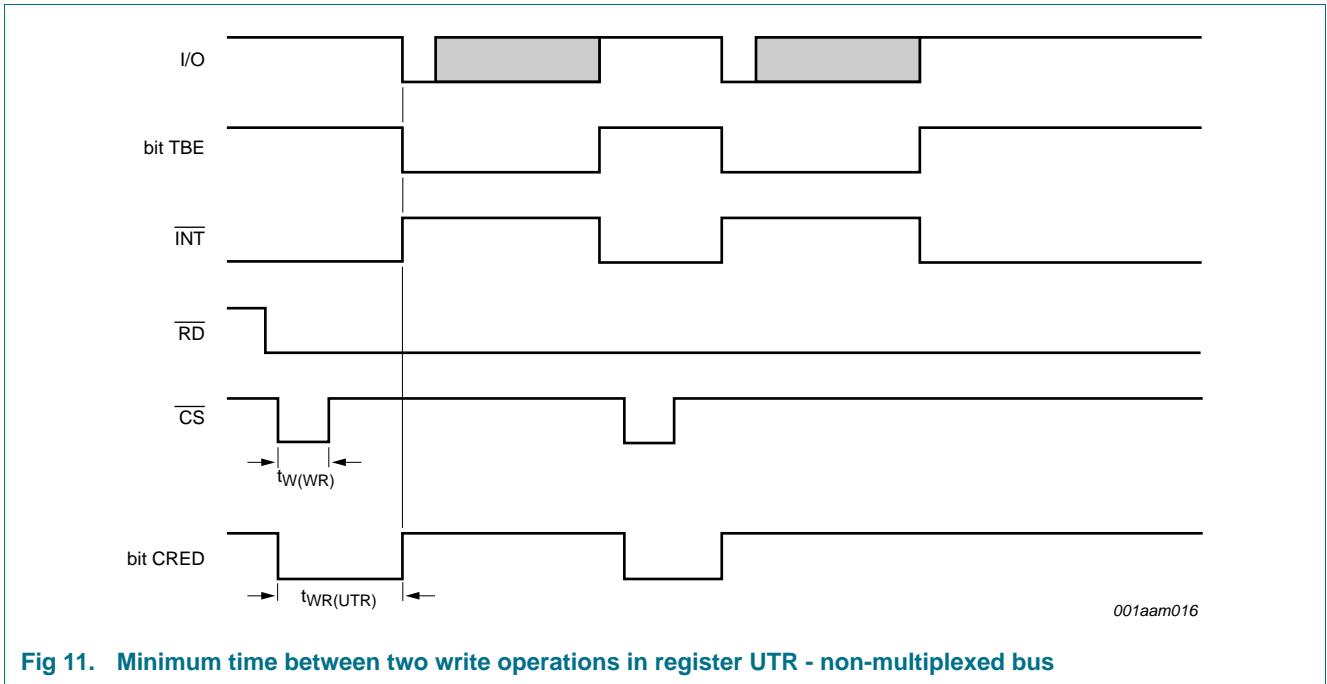

Fig 11. Minimum time between two write operations in register UTR - non-multiplexed bus

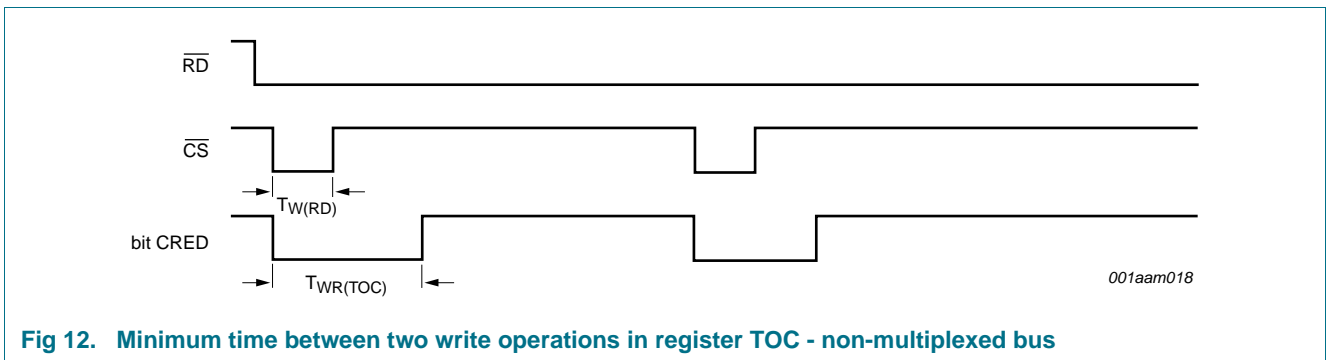

Fig 12. Minimum time between two write operations in register TOC - non-multiplexed bus

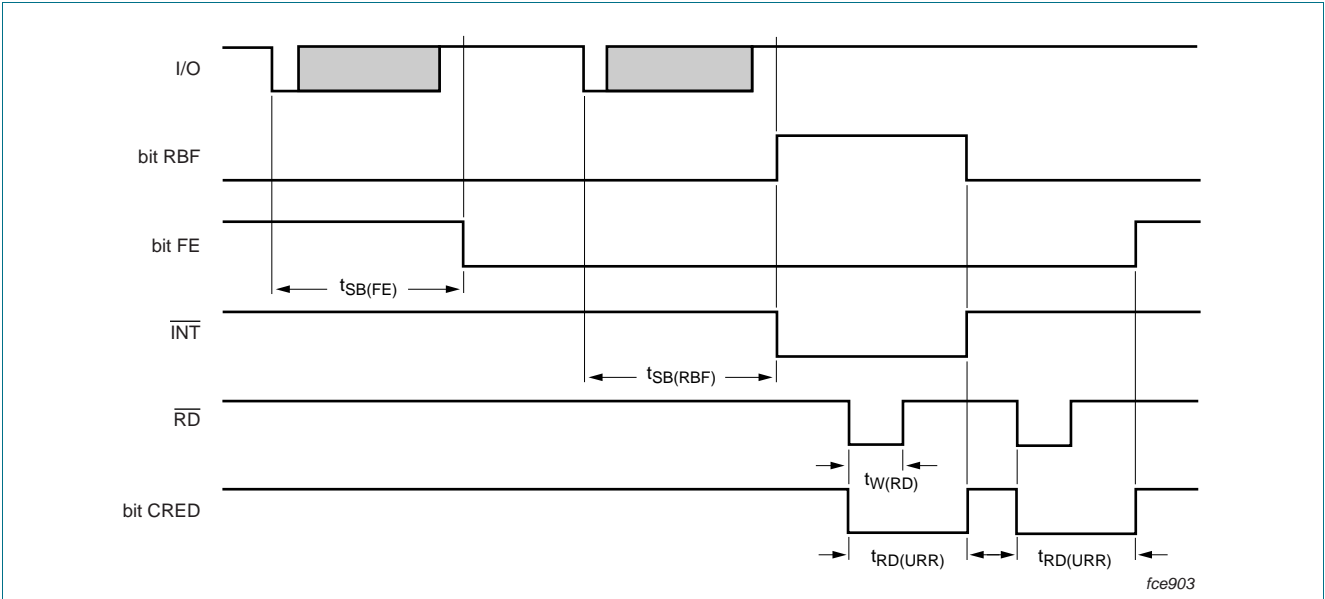

Fig 13. Minimum time between two read operations in register URR - multiplexed mode TDA8007BHL/C3

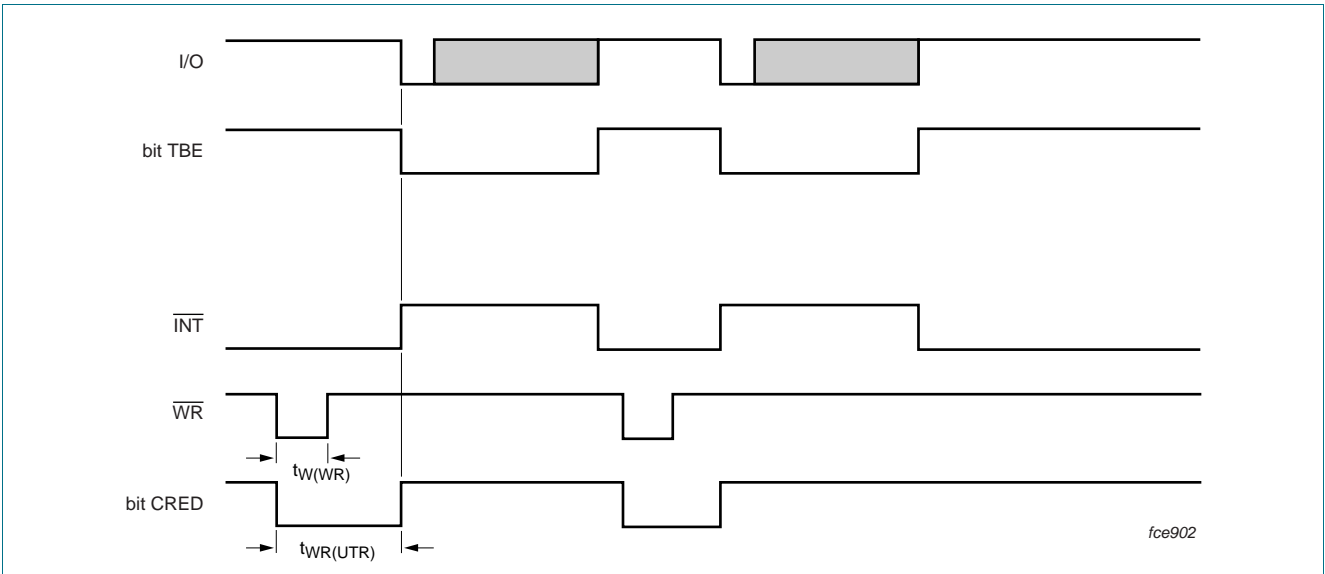

Fig 14. Minimum time between two write operations in register UTR - multiplexed mode TDA8007BHL/C3

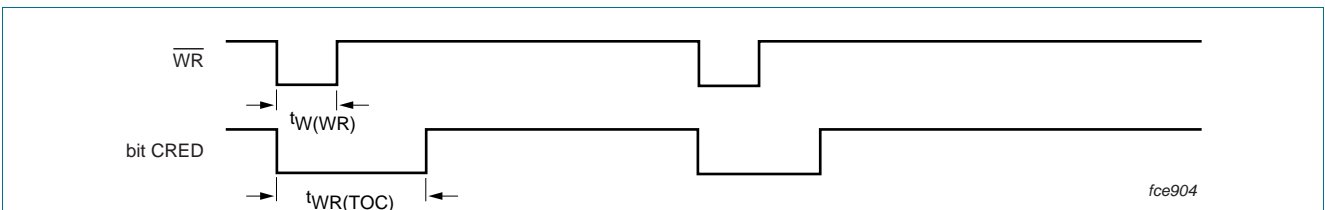

Fig 15. Minimum time between two write operations in register TOC - multiplexed mode TDA8007BHL/C3

### 8.2.2.4 FIFO Control Registers (FSR)

The FCR relates the parity error count and the FIFO length.

**Table 17. Register FCR (address 0Ch; write only)**<sup>[1]</sup>

7	6	5	4	3	2	1	0
FC7	PEC2	PEC1	PEC0	FC3	FL2	FL1	FL0

[1] Register value at reset: all relevant bits are cleared after reset.

**Table 18. Description of FCR bits**

Bit	Symbol	Description
7	FC7	not used
6	PEC2	<p><b>Parity Error Count</b></p> <p>PEC2, PEC1 and PEC0 determine the number of allowed repetitions reception</p> <p>The value 000 indicates that, if only one parity error has occurred, bit PE is set; the value 111 indicates that bit PE will be set after 8 parity errors.</p> <p>In protocol T = 0:</p> <p>If a correct character is received before the programmed error number is reached, the error counter will be reset</p> <ul style="list-style-type: none"> <li>- If the programmed number of allowed parity errors is reached, bit PE in register USR will be set as long as register USR has not been read</li> <li>- If a transmitted character has been NAK by the card, then the TDA8007BHL/C4 will automatically re-transmit it a number of times equal to the value programmed in bits PEC2, PEC1 and PEC0; the character will be resent at 15 ETU</li> </ul> <p>In transmission mode, if bits PEC2, PEC1 and PEC0 are logic 0, then the automatic re-transmission is invalidated; the character manually rewritten in register UTR will start at 13.5 ETU.</p>
5	PEC1	
4	PEC0	
3	FC3	
2	FL2	<b>FIFO length.</b> Bits FL2, FL1 and FL0 determine the depth of the FIFO:
1	FL1	<ul style="list-style-type: none"> <li>• 000 = length 1</li> <li>• 111 = length 8.</li> </ul>
0	FL0	

### 8.2.2.5 UART Status Register (USR)

The USR is used by the microcontroller to monitor the activity of the ISO UART and that of the time-out counter. If any of the status bits FER, OVR, PE, EA, TO1, TO2 or TO3 are set, then signal  $\overline{\text{INT}}$  = low. The bit having caused the interrupt is reset 2 ms after the rising edge of signal  $\overline{\text{RD}}$  during a read operation of register USR.

If bit  $\overline{\text{TBE/RBF}}$  is set and if the mask bit DISTBE/RBF within register UCR2 is not set, then also signal  $\overline{\text{INT}}$  = low. Bit  $\overline{\text{TBE/RBF}}$  is reset 3 clock cycles after data has been written in register UTR, or 3 clock cycles after data has been read from register URR, or when changing from transmission mode to reception mode.

In order to avoid counting these clock cycles, bit CRED (described in register MSR) may be used.

If LCT mode is used for transmitting the last character, then bit TBE is not set at the end of the transmission.

**Table 19. Register USR (address 0Eh; read only)<sup>[1]</sup>**

7	6	5	4	3	2	1	0
TO3	TO2	TO1	EA	PE	OVR	FER	TBE/RBF

[1] Register value at reset: all relevant bits are cleared after reset.

**Table 20. Description of USR bits**

Bit	Symbol	Description
7	TO3	<b>Time-Out counter 3.</b> Bit TO3 is set when counter 3 has reached its terminal count.
6	TO2	<b>Time-Out counter 2.</b> Bit TO2 is set when counter 2 has reached its terminal count.
5	TO1	<b>Time-Out counter 1.</b> Bit TO1 is set when counter 1 has reached its terminal count.
4	EA	<b>Early answer</b> is high if the first START bit on the I/O during ATR has been detected between the first 200 and 368 clock pulses with RST low (all activities on the I/O during the first 200 clock pulses with RST low are not taken into account) and before the first 368 clock pulses with RST high. These two features are re-initialized at each toggling of RST
3	PE	<b>Parity Error (PE).</b> In protocol T = 0, bit PE = 1 if the UART has detected a number of received characters with parity errors equal to the number written in bits PEC2, PEC1 and PEC0 or if a transmitted character has been NAK by the card a number of times equal to the value programmed in bits PEC2, PEC1 and PEC0. It is set at 10.5 ETU in the reception mode and at 11.5 ETU in the transmission mode.  In protocol T = 0, a character received with a parity error is not stored in register FIFO (the card should repeat this character). In protocol T = 1, a character with a parity error is stored in the FIFO and the parity error counter is not active.
2	OVR	<b>Overrun (OVR).</b> Bit OVR = 1 if the UART has received a new character whilst register FIFO was full. In this case, at least one character has been lost.
1	FER	<b>Framing Error (FER).</b> Bit FER = 1 when pin I/O was not in the high impedance state at 10.25 ETU after a START bit. It is reset when register USR has been read-out.
0	TBE/RBF	<b>Transmission Buffer Empty (TBE)/Reception Buffer Full (RBF).</b> Bits TBE and RBF share the same bit within register USR: when in transmission mode the relevant bit is TBE; when in reception mode it is RBF.  Bit TBE = 1 when the UART is in transmission mode and when the microcontroller may write the next character to transmit in register UTR. It is reset when the microcontroller has written data in the transmit register or when bit T/R within register UCR1 has been reset either automatically or by software. After detection of a parity error in transmission, it is necessary to wait 13.5 ETU before rewriting the character which has been NAK by the card. (Manual mode, see Table 18)  Bit RBF = 1 when register FIFO is full. The microcontroller may read some of the characters in register URR, which clears bit RBF.

8.2.3 Card registers

When cards 1, 2 or 3 are selected, the following registers may be used for programming some specific parameters.

8.2.3.1 Programmable Divider Register (PDR)

The programmable divider registers PDR1, PDR2 and PDR3 are used for counting the cards clock cycles forming the ETU (see [Figure 16](#)).

These are auto-reload 8-bit counters.

Table 21. Register PDR1,PRDR2, PDR3 (address 02h; read and write)

7	6	5	4	3	2	1	0
PD7	PD6	PD5	PD4	PD3	PD2	PD1	PD0

[1] Register value at reset: all bits are cleared after reset.

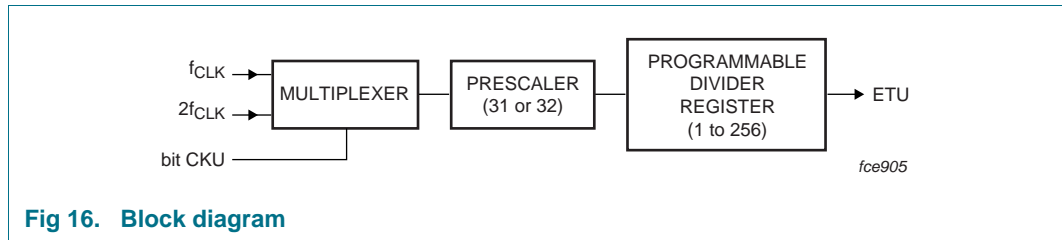

Fig 16. Block diagram

8.2.3.2 UART Configuration Registers (UCR) 2

The UART configuration registers 2 UCR12, UCR22 and UCR32, relate the UART configuration.

Table 22. Register UCR1,UCR2, UCR3 (address 03h; read and write)<sup>[1]</sup>

7	6	5	4	3	2	1	0
UC27	DISTBE/RBF	DISAUX	PDWN	SAN	AUTOCONV	CKU	PSC

[1] Register value at reset: all bits are cleared after reset.

Table 23. Description of UCR2 bits

Bit	Symbol	Description
7	UC27	not used
6	DISTBE/RBF	<b>disable TBE/RBF interrupt bit.</b> If bit DISTBE/RBF = 1, then reception or transmission of a character will not generate an interrupt. This feature is useful for increasing communication speed with the card; in this case, a copy of the bit TBE/RBF within register MSR must be polled (and not the original) in order not to lose priority interrupts which can occur in register USR.
5	DISAUX	<b>disable auxiliary interrupt.</b> If bit DISAUX in register UCR2 is set, then a change on pin INTAUX will not generate an interrupt, but bit INTAUXL will be set. Therefore, it is necessary to read register HSR before bit DISAUX is to be reset to avoid an interrupt by bit INTAUXL. In order to avoid an interrupt during a change of card, it is better to set bit DISAUX in register UCR2 for all cards.



Table 23. Description of UCR2 bits

Bit	Symbol	Description
4	PDWN	<p><b>power-down mode.</b> If bit PDWN is set by software, the crystal oscillator is stopped. This mode allows low power consumption in applications where this is required. During the Power-down mode, it is not possible to select a card other than the one currently selected. There are five ways of escaping from the Power-down mode:</p> <ul style="list-style-type: none"> <li>- withdraw card 1 or 2</li> <li>- Select the TDA8007BHL/C4 by resetting bit CS (this assumes that the TDA8007BHL/C4 had been deselected after setting Power-down mode)</li> <li>- insert card 1 or card 2</li> <li>- Bit INTAUXL has been set due to a change on pin INTAUX</li> <li>- If pin CS = low permanently, reset bit PDWN by software.</li> </ul> <p>After any of these events, the TDA8007BHL/C4 will leave the Power-down mode.</p> <p>Except in the case of a read operation of register HSR, signal <math>\overline{INT}</math> will be pulled to low level. The system microcontroller may then read the status registers after 5 ms, and signal <math>\overline{INT}</math> will return to high level (if the system microcontroller has woken the TDA8007BHL/C4 by re-selecting it, then no bits will be set in the status registers).</p> <p>Note that the Power-down mode can only be entered if bit SUPL has been cleared.</p>
3	SAN	<p><b>synchronous/asynchronous card.</b> Bit SAN = 1 by software if a synchronous card is expected. The UART is then bypassed and only bit 0 in registers URR and UTR is connected to pin I/O. In this case the clock is controlled by bit SC in register CCR.</p>
2	AUTOCONV	<p><b>auto convention.</b> If bit AUTOCONV = 1, then the convention is set by software using bit CONV in register UCR1. If the bit is reset, then the configuration is automatically detected on the first received character whilst the start session (bit SS) is set.</p> <p>Bit AUTOCONV must not be changed during a card session.</p>
1	CKU	<p><b>clock UART.</b> For baud rates other than those given in Table 24, there is the possibility to set bit CKU = 1. In this case, the ETU will last half the number of card clock cycles equal to prescaler PDRx. Note that bit CKU = 1 has no effect if <math>f_{CLK} = f_{XTAL}</math>. This means, for example, that 76800 baud is not possible when the card is clocked with the external frequency on pin XTAL1.</p>
0	PSC	<p><b>prescale Select.</b> If bit PSC = 1, then the prescaler value is 32. If bit PSC = 0, then the prescaler value is 31. One ETU will last a number of cards clock cycles equal to prescaler PDRx. All baud rates specified in the ISO 7816 norm are achievable with this configuration (see Table 24).</p>

**Table 24. Baud rate selection using values F and D**<sup>[1]</sup>

PSC = 31:  $f_{CLK} = 3.58 \text{ MHz}$ ; PSC = 32:  $f_{CLK} = 4.92 \text{ MHz}$

D	F											
	0	1	2	3	4	5	6	9	10	11	12	13
1	31;12 9600	31;12 9600	31;18 6400	31;24 4800	31;36 3200	31;48 2400	31;60 1920	32;16 9600	32;24 6400	32;32 4800	32;48 3200	32;64 2400
2	31;6 19200	31;6 19200	31;9 12800	31;12 9600	31;18 6400	31;24 4800	31;30 3840	32;8 19200	32;12 12800	32;16 9600	32;24 6400	32;32 4800
3	31;3 38400	31;3 38400	31;6 19200	31;9 12800	31;12 9600	31;15 7680	32;4 38400	32;6 25600	32;8 19200	32;12 12800	32;16 9600	
4			31;3 38400	31;6 19200	31;9 12800	31;12 9600	32;2 76800	32;3 51300	32;4 38400	32;6 25600	32;8 19200	
5					31;3 38400	31;6 19200	32;1 153600	32;2 76800	32;3 51300	32;4 38400		
6									32;1 153600	32;2 76800	32;3 51300	32;4 38400
8	31;1 115200	31;1 115200	31;2 57600	31;3 38400	31;4 28800	31;5 23040	32;2 76800	32;3 51300	32;4 38400			
9							31;3 38400					

[1] Example: 31;12 in the table means prescaler set to 31 and PDR set to 12

### 8.2.3.3 Guard Time Registers (GTR)

The guard time registers GTR1, GTR2 and GTR3 are used for storing the number of guard ETU given by the card during ATR. In transmission mode, the UART will wait this number of ETU before transmitting the character stored in register UTR.

When register GTRx = FF:

- In protocol T = 1  
TDA8007BHL/C4 operates at 10.8 ETU
- In protocol T = 0  
TDA8007BHL/C4 operates at 11.8 ETU.

**Table 25. Register GTR1, GTR2, GTR3 (address 05H; read and write)**<sup>[1]</sup>

7	6	5	4	3	2	1	0
GT7	GT6	GT5	GT4	GT3	GT2	GT1	GT0

[1] Register value at reset: all bits are cleared after reset.

### 8.2.3.4 UART Configuration Registers (UCR) 1

The UART configuration registers 1 (UCR11, UCR21 and UCR31) set the parameters of the ISO UART.

**Table 26. Register UCR11, UCR21 and UCR31 (address 06H; read and write)**<sup>[1]</sup>

7	6	5	4	3	2	1	0
UC17	FIP	FC	PROT	T/R	LCT	SS	CONV

[1] Register value at reset: all bits are cleared after reset.

Table 27. Description of UCRx1 bits

Bit	Symbol	Description
7	UC17	not used
6	FIP	<b>Force Inverse Parity (FIP).</b> If bit FIP is set to logic 1, the UART will NAK a correctly received character, and will transmit characters with wrong parity bits.
5	FC	<b>Test.</b> Bit FC is a test bit, and must be left at logic 0.
4	PROT	<b>Protocol (PROT).</b> Bit PROT is set if the protocol is T = 1 (asynchronous) and bit PROT = 0 if the protocol is T = 0.
3	T/R	<b>Transmit/Receive (T/R).</b> Bit T/R is set by software for transmission mode. A change from logic 0 to 1 will set bit TBE in register USR. Bit T/R is automatically reset by hardware if bit LCT has been used before transmitting the last character.
2	LCT	<b>Last Character to Transmit (LCT).</b> Bit LCT is set by software before writing the last character to be transmitted in the UTR. It allows automatic change to reception mode. It is reset by hardware at the end of a successful transmission. When LCT is being reset, the bit T/R is also reset and the ISO 7816 UART is ready for receiving a character.
1	SS	<b>Software convention Setting (SS).</b> Bit SS is set by software before ATR for automatic convention detection and early answer detection. It is automatically reset by hardware at 10.5 ETU after reception of the initial character.
0	CONV	<b>Convention (CONV).</b> Bit CONV is set if the convention is direct. Bit CONV is either automatically written by hardware according to the convention detected during ATR, or by software if the bit AUTOCONV in register UCR2X is set.

### 8.2.3.5 Clock Configuration Registers (CCR)

The clock configuration registers CCR1, CCR2 and CCR3 relate the clock signals:

- For cards 1 and 2, register CCRx defines the clock for the selected card
- For cards 1, 2 and 3, register CCRx defines the clock to the ISO UART. It should be noted that, if bit CKU in the prescaler register of the selected card (register UCR2) is set, then the ISO UART is clocked at twice the frequency of the card, which allows baud rates not foreseen in ISO 7816 norm to be reached.

Table 28. Register CCR1, CCR2 and CCR3 (address 01H; read and write)<sup>[1]</sup>

7	6	5	4	3	2	1	0
CC7	CC6	SHL	GST	SC	AC2	AC1	AC0

[1] Register value at reset: all bits are cleared after reset.

Table 29. Description of CCRx bits

Bit	Symbol	Description
7	CC7	not used
6	CC6	not used
5	SHL	<b>Stop High or Low (SHL).</b> If bit CST = 1, then the clock is stopped at low level if bit SHL = 0, and at high level if bit SHL = 1.

**Table 29. Description of CCRx bits ...continued**

Bit	Symbol	Description
4	CST	<b>Clock Stop (CST).</b> In the case of an asynchronous card, bit CST defines whether the clock to the card is stopped or not; if bit CST is reset, then the clock is determined by bits AC0, AC1 and AC2.
3	SC	<b>Synchronous Clock (SC).</b> In the event of a synchronous card, then contact CLK is the copy of the value of bit SC; in reception mode, the data from the card is available to bit UR0 after a read operation of register URR; in transmission mode, the data is written on the I/O line of the card when register UTR has been written to and remains unchanged when another card is selected.
2 to 0	AC	<b>Alternating Clock (AC).</b> All frequency changes are synchronous, thus ensuring that no spikes or unwanted pulse widths occur during changes.  000 = $f_{XTAL}$ 001 = $\frac{1}{2}f_{XTAL}$ 010 = $\frac{1}{4}f_{XTAL}$ 011 = $\frac{1}{8}f_{XTAL}$ 100 to 111 = $\frac{1}{2}f_{int}$

Clock switching constraints:

- $f_{int}$  is the frequency delivered by the internal oscillator
- In case of  $f_{CLK} = f_{XTAL}$ , the duty cycle must be ensured by the incoming clock signal on pin XTAL1
- When switching from  $\frac{1}{n}f_{XTAL}$  to  $\frac{1}{2}f_{XTAL}$  or vice versa, only bit AC2 must be changed (bits AC1 and AC0 must remain the same). When switching from  $\frac{1}{n}f_{XTAL}$  to  $\frac{1}{2}f_{XTAL}$  to clock stopped or vice versa, only bits CST and SHL must be changed
- When switching from  $\frac{1}{n}f_{XTAL}$  to  $\frac{1}{2}f_{XTAL}$  or vice versa, a delay can occur between the command and the effective frequency change on CLK (the fastest switching time is from  $\frac{1}{2}f_{XTAL}$  to  $\frac{1}{2}f_{int}$  or vice versa, the best for duty cycle is from  $\frac{1}{8}f_{XTAL}$  to  $\frac{1}{2}f_{int}$  or vice versa)
- It is necessary to survey the bit CLKSW in register MSR before re-transmitting commands to the card.

**8.2.3.6 Power Control Registers (PCR)**

The power control registers PCR1 and PCR2:

- Start or stop card sessions
- Read from or write to auxiliary card contacts C4 and C8
- Are available only for cards 1 or 2.

To deactivate the card, only bit START should be reset.

**Table 30. Register PCR1 and PCR2 (address 07H; read and write)<sup>[1]</sup>**

7	6	5	4	3	2	1	0
PCR7	PCR6	C8	C4	1V8	RSTIN	3V/5V	START

[1] Register value at reset: all bits are cleared after reset.

Table 31. Description of PCRx bits

Bit	Symbol	Description
7	PCR7	not used
6	PCR6	not used
5	C8	<b>Contact 8 (C8).</b> When writing to register PCR, pin C8 will output the value of bit C8. When reading from register PCR, bit C8 will store the value on pin C8
4	C4	<b>Contact 4 (C4).</b> When writing to register PCR, pin C4 will output the value of bit C4. When reading from register PCR, bit C4 will store the value on pin C4.
3	1V8	<b>1.8 V cards.</b> If bit 1V8 is set, then $V_{CC} = 1.8\text{ V}$ ; it should be noted that no specification is guaranteed with this $V_{CC}$ voltage when the supply voltage $V_{DD}$ is inferior to 3 V
2	RSTIN	<b>Reset In (RSTIN).</b> When the card is activated, pin RST is the copy of the value written in bit RSTIN.
1	3V/5V	<b>3 V or 5 V cards.</b> If bit 3V/5V = 1, then $V_{CC} = 3\text{ V}$ ; if bit 3V/5V = 0, then $V_{CC} = 5\text{ V}$ .
0	START	<b>Start.</b> If the microcontroller sets bit START = 1, then the selected card is activated (see <a href="#">Section 8.6</a> ); if the microcontroller resets bit START = 0, then the card is deactivated (see <a href="#">Section 8.7</a> ). Bit START is automatically reset in case of emergency deactivation. To deactivate the card, only bit START should be reset.

8.2.4 register summary

Table 32.

Addr	Name	R/W	7	6	5	4	3	2	1	0	Value[1] at reset	Value[1] when RIU = 0
00	CSR[2]	R/W	0	0	1	0	RIU	SC3	SC2	SC1	00110000	0011 0000
01	CCR[2]	R/W	not used	not used	SHL	CST	SC	AC2	AC1	AC0	XX00 0000	XXuu uuuu
02	PDR[2]	R/W	PD7	PD6	PD5	PD4	PD3	PD2	PD1	PD0	0000 0000	uuuu uuuu
03	UCR[2]	R/W	not used	DISTBE/R BF	DISAUX	PDWN	SAN	AUTO $\overline{C}$	CKU	PSC	X000 0000	uuuu uuuu
05	GTR[2]	R/W	GT7	GT6	GT5	GT4	GT3	GT2	GT1	GT0	0000 0000	uuuu uuuu
06	UCR[2]	R/W	not used	FIP	FC	PROT	T/R	LCT	SS	CONV	X000 0000	Xuuu 00uu
07	PCR[2]	R/W	not used	not used	C8	C4	1V8	RSTIN	3V/5V	START	XX11 0000	XX11 uuuu
08	TOC	R/W	TOC7	TOC6	TOC5	TOC4	TOC3	TOC2	TOC1	TOC0	0000 0000	0000 0000
09	TOR1	W	TOL7	TOL6	TOL5	TOL4	TOL3	TOL2	TOL1	TOL0	0000 0000	uuuu uuuu
0A	TOR2	W	TOL15	TOL14	TOL13	TOL12	TOL11	TOL10	TOL9	TOL8	0000 0000	uuuu uuuu
0B	TOR3	W	TOL23	TOL22	TOL21	TOL20	TOL19	TOL18	TOL17	TOL16	0000 0000	uuuu uuuu
0C	MSR	R	CLKSW	FE	BGT	CRED	PR2	PR1	INTAUX	TBE/RBF	0101 XXX0	u1u1 uuu0
0C	FCR	W	not used	PEC2	PEC1	PEC0	not used	FL2	FL1	FL0	X000 X000	Xuuu Xuuu
0D	URR	R	UR7	UR6	UR5	UR4	UR3	UR2	UR1	UR0	0000 0000	0000 0000
0D	UTR	W	UT7	UT6	UT5	UT4	UT3	UT2	UT1	UT0	0000 0000	0000 0000
0E	USR	R	TO3	TO2	TO1	EA	PE	OVR	FER	TBE/RBF	0000 0000	0000 0000
	HSR	R	not used	PRTL2	PRTL1	SUPL	PRL2	PRL1	INTAUXL	PTL	X001 0000	Xuuu XXXu

[1] X = undefined; u = no change.

[2] Registers PDR, GTR, UCR1, UCR2, CCR and PCR vary according to the card selected.

**8.3 Supply**

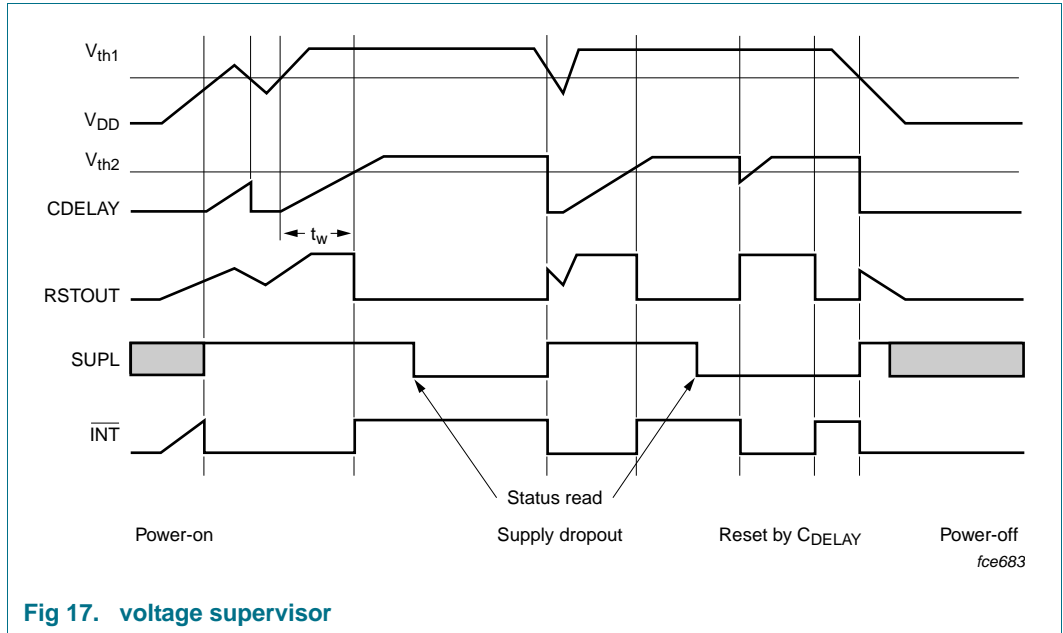

**Fig 17. voltage supervisor**

The TDA8007BHL/C4 operates within a supply voltage range of 2.7 V to 6 V. The supply pins are V<sub>DD</sub>, V<sub>DDA</sub>, GND and AGND.

Pins V<sub>DDA</sub> and AGND supply the analog drivers to the cards and have to be decoupled externally because of the large current spikes that the cards and the step-up converter can create. V<sub>DDA</sub> may be different from V<sub>DD</sub>.

Pins V<sub>DD</sub> and GND supply the remainder of the chip. An integrated spike killer ensures that the contacts to the cards remain inactive during power-up and power-down. An internal voltage reference is generated for use within the step-up converter, the voltage supervisor and the V<sub>CC</sub> generators.

The voltage supervisor generates an alarm pulse when V<sub>DD</sub> is too low to ensure proper operation. The alarm pulse length is defined by an external capacitor tied to pin DELAY and is typically 1 ms per 2 nF.

The alarm pulse may be used as a reset pulse by the system microcontroller (pin RSTOUT = high). It can also be used to block any spurious noise on card contacts during the microcontrollers reset, or to force an automatic deactivation of the contacts in the event of a supply drop-out (see [Section 8.5](#) and [8.7](#)).

After power-on, or after a voltage drop, bit SUPL is set within register HSR and remains set until register HSR is read-out outside the alarm pulse. Signal INT = low for the duration that signal RSTOUT is active.

## 8.4 Step up converter

Except for the  $V_{CC}$  generator and the other cards contacts buffers, the whole circuit is powered by  $V_{DD}$ , and  $V_{DDA}$ . If the supply voltage is 2.5 V, then a higher voltage is needed for the ISO contacts supply. When a card session is requested by the microcontroller, the sequencer first enables the step-up converter (a switched capacitors type) which is clocked by an internal oscillator at a frequency of approximately 2.5 MHz.

Supposing that  $V_{CC}$  is the maximum of  $V_{CC1}$  and  $V_{CC2}$ , then the possible situations are:

- $V_{CC} = 5\text{ V}$ 
  - For  $V_{DD} = 3\text{ V}$  the step-up converter acts as a voltage tripler with regulation of  $V_{UP}$  at approximately 5.5 V
  - For  $V_{DD} = 5\text{ V}$  the step-up converter acts as a voltage doubler with regulation of  $V_{UP}$  at approximately 5.5 V
- $V_{CC} = 3\text{ V}$ 
  - For  $V_{DD} = 3\text{ V}$  the step-up converter acts as a voltage doubler with regulation of  $V_{UP}$  at approximately 4.0 V
  - For  $V_{DD} = 5\text{ V}$  the step-up converter acts as a voltage follower and  $V_{DD}$  is applied to  $V_{UP}$
- $V_{CC} = 1.8\text{ V}$ 
  - The step-up converter acts as a voltage follower for any value of  $V_{DD}$ .

The recognition of the supply voltage is done by the TDA8007BHL/C4 at approximately 3.5 V.

The output voltage  $V_{UP}$  is fed to the  $V_{CC}$  generators.  $V_{CC}$  and GNDC are used as a reference for all other card contacts.

## 8.5 ISO 7816 security

The correct sequence during activation and deactivation of the cards is ensured by two specific sequencers, the clock is defined by a division ratio of the internal oscillator.

Activation (bit START = 1 in registers PCR1 or PCR2) is only possible if the card is present (pin PRES is active high with an internal current source to ground) and if the supply voltage is correct (voltage supervisor not active).

The presence of the cards is signalled to the microcontroller by register HSR. Bits PR1 or PR2 in register MSR are set if card 1 or 2 is present. Bits PRL1 or PRL2 are set if pins PRES1 or PRES2 have been toggled.

During a session, the sequencer performs an automatic emergency deactivation on one card in the event of card take-off, or short-circuit. Both cards are automatically deactivated in the event of a supply voltage drop, or overheating. Register HSR is updated and the INT line falls so that the system microcontroller is aware of what happened.



8.6 Activation sequence

When the cards are inactive, pins V<sub>CC</sub>, CLK, RST, C4x, C8x and I/O are at low level and have a low impedance with respect to ground. The step-up converter is stopped.

When everything is satisfactory (voltage supply, card present and no hardware problems), the system microcontroller may initiate an activation sequence of a present card.

After selecting the card and leaving the UART reset mode, and then configuring the necessary parameters for the counters and the UART, bit START can be set within register PCR at t<sub>0</sub> (see Figure 18)

1. The step-up converter is started (t<sub>1</sub>); if one card was already active, then the step-up converter was already on and nothing more occurs at this step.
2. Pin V<sub>CC</sub> starts rising (t<sub>2</sub>) from 0 V to 3 V or 5 V with a controlled rise time of 0.17 V/μs (typical).
3. Pin I/O rises to V<sub>CC</sub> (t<sub>3</sub>); pins C4x and C8x also rise if bits C4 and C8 within register PCR have been set to logic 1 (integrated 14 kΩ pull-up resistors to V<sub>CC</sub>).
4. Clock pulse CLK is sent to the card (t<sub>4</sub>) and pin RST is enabled.
5. After a number of CLK pulses that can be counted with the time-out counter, bit RSTIN may be set by software and pin RST will then rise to V<sub>CC</sub>.
6. The sequencer is clocked by 1/64f<sub>int</sub> which leads to a time interval of t = 25 μs (typical).

Thus:

$$t_1 = 0 \text{ to } \frac{1}{64}t$$

$$t_2 = t_1 + \frac{3}{2}t$$

$$t_3 = t_1 + \frac{7}{2}t$$

$$t_4 = t_1 + 4t.$$

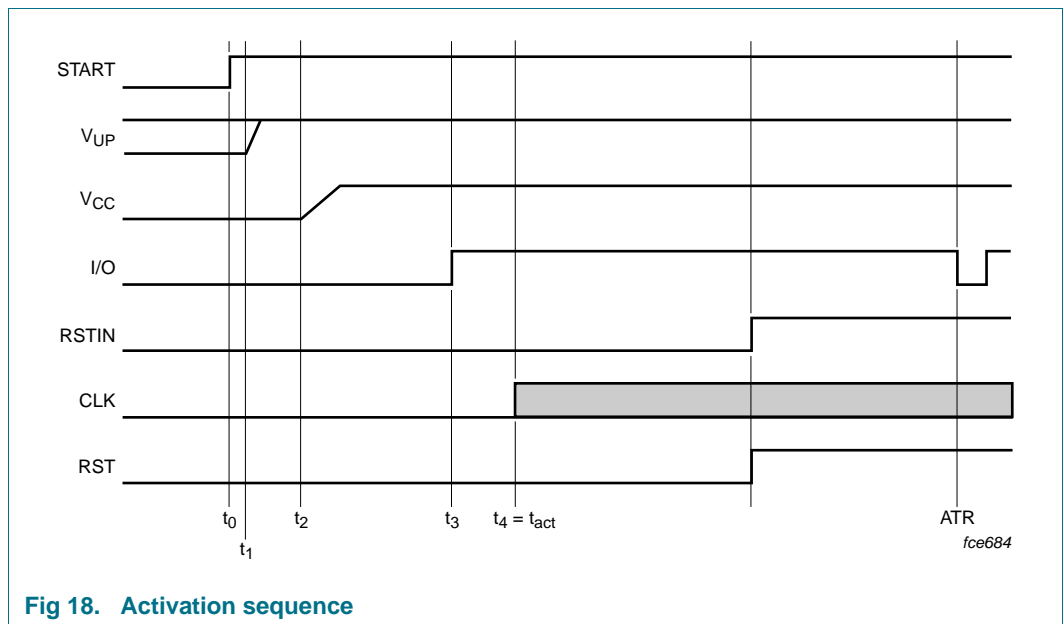

Fig 18. Activation sequence

### 8.7 Deactivation sequence

When the session is completed, the microcontroller resets bit START at  $t_{10}$ . The circuit then executes an automatic deactivation sequence (see [Figure 19](#)):

1. The card is reset by signal RST = low ( $t_{11}$ ).
2. Clock pulse CLK is stopped ( $t_{12}$ ).
3. Pins I/O, C4x and C8x fall to 0 V ( $t_{13}$ ).
4. Pin  $V_{CC}$  falls to 0 V with typical 0.17 V/ $\mu$ s slew rate ( $t_{14}$ ).
5. The step-up converter is stopped ( $t_{15}$ ) and pins CLK, RST,  $V_{CC}$  and I/O become low impedance to ground, if both cards are inactive.

Thus:

$$t_{11} = t_{10} + \frac{1}{64}t$$

$$t_{12} = t_{11} + \frac{1}{2}t$$

$$t_{13} = t_{11} + t$$

$$t_{14} = t_{11} + \frac{3}{2}t$$

$$t_{15} = t_{11} + \frac{7}{2}t$$

$t_{de}$  = time that  $V_{CC}$  needs to decrease to less than 0.4 V.

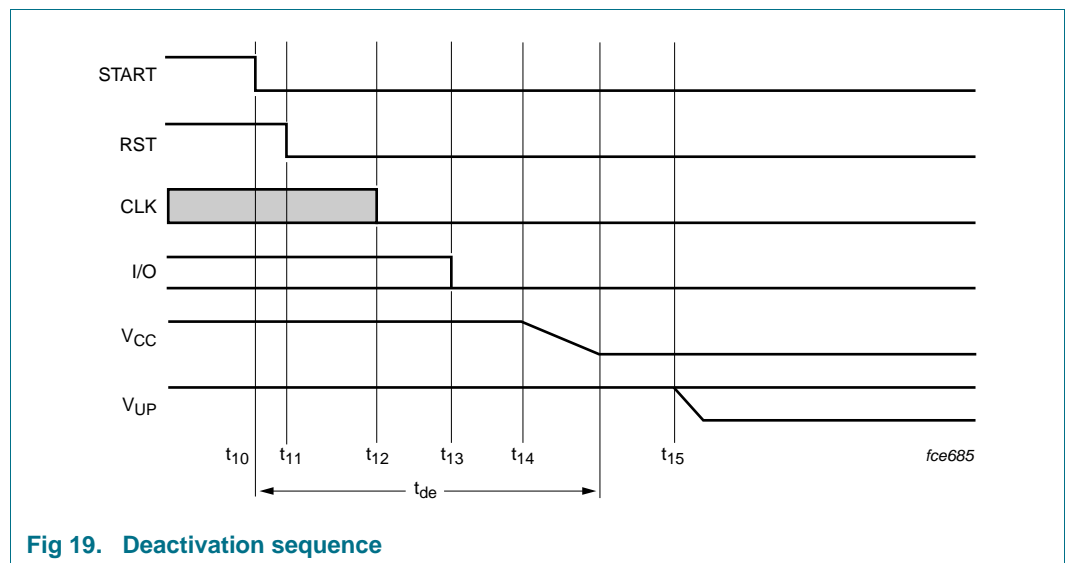

Fig 19. Deactivation sequence

## 9. Limiting values

**Table 33. Limiting values**
*In accordance with the Absolute Maximum Rating System (IEC 60134).*

Symbol	Parameter	Conditions	Min	Max	Unit
V <sub>DD</sub>	supply voltage		-0.5	+6.5	V
V <sub>DDA</sub>	analog supply voltage		-0.5	+6.5	V
V <sub>I</sub>	input voltage	on pins SAM, SAP, SBM, SBP and V <sub>UP</sub>	-0.5	+7.5	V
		on all other pins	-0.5	V <sub>DD</sub> + 0.5	V
P <sub>tot</sub>	total power dissipation	T <sub>amb</sub> = - 25 to +85 °C	-	700	mW
T <sub>stg</sub>	storage temperature		-55	+150	°C
T <sub>j</sub>	junction temperature		-	125	°C
V <sub>esd</sub>	electrostatic discharge voltage	human body model <a href="#">[1]</a>			
		on pins I/O1, I/O2, V <sub>CC1</sub> , V <sub>CC2</sub> , RST1, RST2, CLK1, CLK2, CGND1, CGND2, PRES1 and PRES2	-6	+6	kV
		on pins C4x, C8x	-5	+5	kV
		on all other pins	-2	+2	kV

[1] Human body model as define in JEDEC Standard JESD22-A114-B dated June 2000

## 10. Thermal characteristics

**Table 34. Thermal characteristics**

Symbol	Package name	Parameter	Conditions	Typ	Unit
R <sub>th(j-a)</sub>	LQFP48	thermal resistance from junction to ambient	in free air	78	K/W

## 11. Characteristics

**Table 35. Characteristics**
*V<sub>DD</sub> = 3.3 V; V<sub>DDA</sub> = 3.3 V; T<sub>amb</sub> = 25 °C; unless otherwise specified.*

Symbol	Parameter	Conditions	Min	Typ	Max	Unit
<b>Supplies</b>						
V <sub>DD</sub>	supply voltage		2.7	-	6.0	V
V <sub>DDA</sub>	analog supply voltage	step-up converter	V <sub>DD</sub>	-	6.0	V
I <sub>DD(pd)</sub>	supply current in power-down mode	cards inactive; f <sub>XTAL</sub> = 0 Hz	-	-	350	μA
		cards active; V <sub>CC</sub> = 5 V; f <sub>CLK</sub> = 0 Hz; f <sub>XTAL</sub> = 0 Hz	-	-	3	mA
I <sub>DD(sm)</sub>	supply current in sleep mode	cards active; f <sub>CLK</sub> = 0 Hz	-	-	5.5	mA

**Table 35. Characteristics ...continued**

$V_{DD} = 3.3\text{ V}$ ;  $V_{DDA} = 3.3\text{ V}$ ;  $T_{amb} = 25\text{ }^{\circ}\text{C}$ ; unless otherwise specified.

Symbol	Parameter	Conditions	Min	Typ	Max	Unit
$I_{DD(oper)}$	supply current in operating modem	5 V cards	-	-	315	mA
		$I_{CC1} = 65\text{ mA}$ ; $I_{CC2} = 15\text{ mA}$ ; $f_{XTAL} = 20\text{ MHz}$ ; $f_{CLK} = 10\text{ MHz}$ ; $V_{DD} = 2.7\text{ V}$				
		3 V cards	-	-	215	mA
		$I_{CC1} = 50\text{ mA}$ ; $I_{CC2} = 30\text{ mA}$ ; $f_{XTAL} = 20\text{ MHz}$ ; $f_{CLK} = 10\text{ MHz}$ $V_{DD} = 2.7\text{ V}$				
	$V_{DD} = 5\text{ V}$	-	-	100	mA	

**Voltage supervisor; see Figure 17**

$V_{th1}$	threshold voltage on pin $V_{DD}$	falling	2.10	-	2.50	V
$V_{hys1}$	hysteresis on $V_{th1}$		50	-	170	mV

**Capacitor connection: pin DELAY**

$V_{th2}$	threshold voltage		-	1.25	-	V
$V_o$	output voltage		-	-	$V_{DD} + 0.3$	V
$I_o$	output current	$V_{DELAY} = 0\text{ V}$ (charge)	-	-2	-	$\mu\text{A}$
		$V_{DELAY} = V_{DD}$ (discharge)	-	2	-	mA
$C_o$	output capacitance		1	-	-	nF
$t_W$	alarm pulse width	$C_{DELAY} = 22\text{ nF}$	-	10	-	ms

**Output: pin RSTOUT (open-drain output)**

**Active high option**

$V_{OH}$	high-level output voltage	$I_{OH} = -1\text{ mA}$	$0.8V_{DD}$	-	$V_{DD} + 0.3$	V
$I_{OL}$	low-level output current	$V_{OL} = 0\text{ V}$	-	-	-10	$\mu\text{A}$

**Active low option**

$I_{OH}$	high-level output current	$V_{OH} = 5\text{ V}$	-	-	10	$\mu\text{A}$
$V_{OL}$	low-level output voltage	$I_{OL} = 2\text{ mA}$	-0.3	-	+0.4	V

**Crystal oscillator**

$f_{XTAL}$	crystal frequency		4	-	20	MHz
$f_{ext}$	external frequency on pin XTAL1		0	-	20	MHz

**Step-up converter**

$f_{int}$	internal oscillator frequency		2	2.5	3.7	MHz
$V_{VUP}$	voltage on pin $V_{VUP}$	at least one 5 V card	-	5.7	-	V
		both 3 V cards	-	4.1	-	V
$V_{det(dt)}$	detection voltage on pin $V_{DD}$ for doubler or tripler selection		3.4	3.5	3.6	V

**Reset output to the cards: pins RST1 and RST2**

$V_{o(inactive)}$	output voltage in inactive mode	no load	0	-	0.1	V
		$I_{o(inactive)} = 1\text{ mA}$	0	-	0.3	V
$I_{o(inactive)}$	output current in inactive mode	$V_o = 0\text{ V}$	0	-	-1	mA
$V_{OL}$	low-level output voltage	$I_{OL} = 200\text{ mA}$	0	-	0.3	V
$V_{OH}$	high-level output voltage	$I_{OH} = -200\mu\text{A}$	$V_{CC} - 0.5$	-	$V_{CC}$	V

**Table 35. Characteristics ...continued**

$V_{DD} = 3.3\text{ V}$ ;  $V_{DDA} = 3.3\text{ V}$ ;  $T_{amb} = 25\text{ °C}$ ; unless otherwise specified.

Symbol	Parameter	Conditions	Min	Typ	Max	Unit
$t_r$	rise time	$C_L = 30\text{ pF}$	-	-	0.1	$\mu\text{s}$
$t_f$	fall time	$C_L = 30\text{ pF}$	-	-	0.1	$\mu\text{s}$

**Clock output to the cards: pins CLK1 and CLK2**

$V_{o(\text{inactive})}$	output voltage in inactive mode	no load	0	-	0.1	V
		$I_{o(\text{inactive})} = 1\text{ mA}$	0	-	0.3	V
$I_{o(\text{inactive})}$	output current in inactive mode	$V_o = 0\text{ V}$	0	-	-1	mA
$V_{OL}$	low-level output voltage	$I_{OL} = 200\text{ }\mu\text{A}$	0	-	0.3	V
$V_{OH}$	high-level output voltage	$I_{OH} = -200\text{ }\mu\text{A}$	$V_{CC} - 0.5$	-	$V_{CC}$	V
$t_r$	rise time	$C_L = 30\text{ pF}$	-	-	8	ns
$t_f$	fall time	$C_L = 30\text{ pF}$	-	-	8	ns
$f_{CLK}$	clock frequency	idle configuration (1 MHz)	1	-	1.85	MHz
		operational	0	-	10	MHz
$\delta$	duty factor	$C_L = 30\text{ pF}$	45	-	55	%
SR	slew rate (rise and fall)	$C_L = 30\text{ pF}$	0.2	-	-	V/ns

**Card supply output voltage: pins  $V_{CC1}$  and  $V_{CC2}$ <sup>[1]</sup>**

$V_{o(\text{inactive})}$	output voltage in inactive mode	no load	0	-	0.1	V
		$I_{o(\text{inactive})} = 1\text{ mA}$	0	-	0.3	V
$I_{o(\text{inactive})}$	output current in inactive mode	$V_o = 0\text{ V}$	-	-	-1	mA
$V_{CC}$	output voltage in active mode	5 V card; $I_{CC} < 65\text{ mA}$	4.75	5	5.25	V
		3 V card; $I_{CC} < 50\text{ mA}$	2.78	3	3.22	V
		1.8 V card; $I_{CC} < 30\text{ mA}$	1.65	1.8	1.95	V
		5 V card; current pulses of 40 nC with $I < 200\text{ mA}$ , $t < 400\text{ ns}$ and $f < 20\text{ MHz}$	4.6	-	5.4	V
		3 V card; current pulses of 24 nC with $I < 200\text{ mA}$ , $t < 400\text{ ns}$ and $f < 20\text{ MHz}$	2.75	-	3.25	V
		1.8 V card; current pulses of 12 nC with $I < 200\text{ mA}$ , $t < 400\text{ ns}$ and $f < 20\text{ MHz}$	1.62	-	1.98	V
		$I_{CC}$	output current	5 V card; $V_{CC} = 0\text{ to }5\text{ V}$	-	-
		3 V card; $V_{CC} = 0\text{ to }3\text{ V}$	-	-	-50	mA
		1.8 V card; $V_{CC} = 0\text{ to }1.8\text{ V}$	-	-	-30	mA
$I_{CC1} + I_{CC2}$	sum of both output currents		-	-	-80	mA
SR	slew rate	up or down; maximum capacitance of 300 nF	0.05	0.16	0.22	V/ $\mu\text{s}$

**Data lines: pins I/O1 and I/O2<sup>[2]</sup>**

$R_{pu}$	internal pull-up resistance	between pin I/O and $V_{CC}$	11	14	17	k $\Omega$
$V_{o(\text{inactive})}$	output voltage in inactive mode	no load	0	-	0.1	V
		$I_{o(\text{inactive})} = 1\text{ mA}$	-	-	0.3	V
$I_{o(\text{inactive})}$	output current in inactive mode	$V_o = 0\text{ V}$	-	-	-1	mA

**Table 35. Characteristics ...continued**

$V_{DD} = 3.3\text{ V}$ ;  $V_{DDA} = 3.3\text{ V}$ ;  $T_{amb} = 25\text{ }^{\circ}\text{C}$ ; unless otherwise specified.

Symbol	Parameter	Conditions	Min	Typ	Max	Unit
<i>Configured as output</i>						
$V_{OL}$	low-level output voltage	$I_{OL} = 1\text{ mA}$	0	-	0.3	V
$V_{OH}$	high-level output voltage	$I_{OH} < -20\text{ }\mu\text{A}$	$0.8V_{CC}$	-	$V_{CC} + 0.25$	V
		$I_{OH} < -40\text{ }\mu\text{A}$ for 5 V and 3 V cards	$0.75V_{CC}$	-	$V_{CC} + 0.25$	V
$t_{o(r)}$ , $t_{o(f)}$	output transition time (rise and fall time)	$C_L < 30\text{ pF}$	-	-	0.1	$\mu\text{s}$
<i>Configured as input</i>						
$V_{IL}$	low-level input voltage		-0.3	-	+0.8	V
$V_{IH}$	high-level input voltage		1.5	-	$V_{CC}$	V
$I_{IL}$	low-level input current	$V_{IL} = 0\text{ V}$	-	-	600	$\mu\text{A}$
$I_{LIH}$	high-level input leakage current	$V_{IH} = V_{CC}$	-	-	20	$\mu\text{A}$
$t_{i(r)}$ , $t_{i(f)}$	input transition time (rise and fall time)	$C_L < 30\text{ pF}$	-	-	1.2	$\mu\text{s}$
<b>Auxiliary cards contacts: pins C41, C81, C42 and C82</b>						
$V_{o(\text{inactive})}$	output voltage in inactive mode	no load	0	-	0.1	V
		$I_{o(\text{inactive})} = 1\text{ mA}$	-	-	0.3	V
$I_{o(\text{inactive})}$	output current in inactive mode	$V_o = 0\text{ V}$	-	-	-1	mA
$t_{W(\text{pu})}$	active pull-up pulse width		-	200	-	ns
$R_{\text{int}(\text{pu})}$	internal pull-up resistance	between pins C4x or C8x and $V_{CC}$	8	10	12	$\text{k}\Omega$
$f_{\text{max}}$	maximum frequency	on card contact pins	-	-	1	MHz
<i>Configured as output</i>						
$V_{OL}$	low-level output voltage	$I_{OL} = 1\text{ mA}$	0	-	0.3	V
$V_{OH}$	high-level output voltage	$I_{OH} < -20\mu\text{A}$	$0.8V_{CC}$	-	$V_{CC} + 0.25$	V
		$I_{OH} < -40\mu\text{A}$ for 5 and 3 V cards	$0.75V_{CC}$	-	$V_{CC} + 0.25$	V
$t_{o(r)}$ , $t_{o(f)}$	output transition time (rise and fall time)	$C_L = 30\text{ pF}$	-	-	0.1	$\mu\text{s}$
<i>Configured as input</i>						
$V_{IL}$	low-level input voltage		-	-	+0.8	V
$V_{IH}$	high-level input voltage		1.5	-	$V_{CC}$	V
$I_{IL}$	low-level input current	$V_{IL} = 0\text{ V}$	-	-	600	$\mu\text{A}$
$I_{LIH}$	high-level input leakage current	$V_{IH} = V_{CC}$	-	-	20	$\mu\text{A}$
$t_{i(r)}$ , $t_{i(f)}$	input transition time (rise and fall time)	$C_L = 30\text{ pF}$	-	-	1.2	$\mu\text{s}$
<b>Timing</b>						
$t_{\text{act}}$	activation sequence duration	see <a href="#">Figure 18</a>	-	-	130	$\mu\text{s}$
$t_{\text{de}}$	deactivation sequence duration	see <a href="#">Figure 19</a>	-	-	150	$\mu\text{s}$
<b>Protection and limitation</b>						
$I_{CC(\text{sd})}$	shutdown and limitation current at pin $V_{CC}$		-	-100	-	mA
$I_{I/O(\text{lim})}$	limitation current on pin I/O		-15	-	+15	mA
$I_{\text{CLK}(\text{lim})}$	limitation current on pin CLK		-70	-	+70	mA

**Table 35. Characteristics ...continued** $V_{DD} = 3.3\text{ V}$ ;  $V_{DDA} = 3.3\text{ V}$ ;  $T_{amb} = 25\text{ }^{\circ}\text{C}$ ; unless otherwise specified.

Symbol	Parameter	Conditions	Min	Typ	Max	Unit
$I_{RST(sd)}$	shutdown current on pin RST		-	-20	-	mA
$I_{RST(lim)}$	limitation current on pin RST		-20	-	+20	mA
$T_{sd}$	shutdown temperature		-	150	-	$^{\circ}\text{C}$
<b>Card presence inputs: pins PRES1 and PRES2</b>						
$V_{IL}$	low-level input voltage		-	-	$0.3V_{DD}$	V
$V_{IH}$	high-level input voltage		$0.7V_{DD}$	-	-	V
$I_{OL}$	low-level output leakage current	$V_{OL} = 0.4\text{ V}$	-	-	10	$\mu\text{A}$
$I_{OH}$	high-level output leakage current	$V_{OH} = 2.5\text{ V}$	-	-	55	$\mu\text{A}$
<b>Bidirectional data bus: pins D0 to D7</b>						
<i>Configured as input</i>						
$V_{IL}$	low-level input voltage		-	-	$0.3V_{DD}$	V
$V_{IH}$	high-level input voltage		$0.7V_{DD}$	-	-	V
$I_{LIL}$	low-level input leakage current		-20	-	+20	$\mu\text{A}$
$I_{LIH}$	high-level input leakage current		-20	-	+20	$\mu\text{A}$
$C_L$	load capacitance		-	-	10	pF
<i>Configured as output</i>						
$V_{OL}$	low-level output voltage	$I_{OL} = 5\text{ mA}$	-	-	$0.2V_{DD}$	V
$V_{OH}$	high-level output voltage	$I_{OH} = -5\text{ mA}$	$0.8V_{DD}$	-	-	V
$t_{o(r)}$ , $t_{o(f)}$	output transition time (rise and fall time)	$C_L = 50\text{ pF}$	-	-	25	ns
<b>Logic inputs: pins AD0, AD1, AD2, AD3, INTAUX, CS, RD and WR</b>						
$V_{IL}$	low-level input voltage		-0.3	-	$0.3V_{DD}$	V
$V_{IH}$	high-level input voltage		$0.7V_{DD}$	-	$V_{DD} + 0.3$	V
$I_{LIL}$	low-level input leakage current		-20	-	+20	$\mu\text{A}$
$I_{LIH}$	high-level input leakage current		-20	-	+20	$\mu\text{A}$
$C_L$	load capacitance		-	-	10	pF
<b>Logic inputs: pins ALE: only applicable for TDA8007BHL/C3</b>						
$V_{IL}$	low-level input voltage		-0.3	-	$0.3V_{DD}$	V
$V_{IH}$	high-level input voltage		$0.7V_{DD}$	-	$V_{DD} + 0.3$	V
$I_{LIL}$	low-level input leakage current		-20	-	+20	$\mu\text{A}$
$I_{LIH}$	high-level input leakage current		-20	-	+20	$\mu\text{A}$
$C_L$	load capacitance		-	-	10	pF
<b>Auxiliary input and output: pin I/OAUX<sup>[4]</sup></b>						
$R_{int(pu)}$	internal pull-up resistance	between pin I/OAUX and $V_{DD}$	11	-	17	k $\Omega$
$f_{max}$	maximum frequency	on pin I/OAUX	-	-	1	MHz
<i>Configured as input</i>						
$V_{IL}$	low-level input voltage		-0.3	-	$0.3V_{DD}$	V
$V_{IH}$	high-level input voltage		$0.7V_{DD}$	-	$V_{DD} + 0.3$	V
$I_{LIH}$	high-level input leakage current		-20	-	+20	$\mu\text{A}$
$I_{IL}$	low-level input current	$V_{IL} = 0\text{ V}$	-	-	-600	$\mu\text{A}$

**Table 35. Characteristics ...continued** $V_{DD} = 3.3\text{ V}$ ;  $V_{DDA} = 3.3\text{ V}$ ;  $T_{amb} = 25\text{ }^{\circ}\text{C}$ ; unless otherwise specified.

Symbol	Parameter	Conditions	Min	Typ	Max	Unit
$t_{i(r)}$ , $t_{i(f)}$	input transition time (rise and fall time)	$C_L = 30\text{ pF}$	-	-	1.2	$\mu\text{s}$
<i>Configured as output</i>						
$V_{OL}$	low-level output voltage	$I_{OL} = 1\text{ mA}$	-	-	300	mV
$V_{OH}$	high-level output voltage	$I_{OH} = 40\text{ mA}$	$0.75V_{DD}$	-	$V_{DD} + 0.25$	V
$t_{o(r)}$ , $t_{o(f)}$	output transition time (rise and fall time)	$C_L = 30\text{ pF}$	-	-	0.1	$\mu\text{s}$
<b>Interrupt line: pin <math>\overline{\text{INT}}</math> (open-drain output)</b>						
$V_{OH}$	low-level output voltage	$I_{OH} = 2\text{ mA}$	-	-	0.3	V
$I_{LIH}$	high-level input leakage current		-	-	10	$\mu\text{A}$

- [1] To meet these specifications, two ceramic multilayer capacitors with low ESR of minimum 100 nF should be used.
- [2] Pin I/O1 has an integrated 14 k $\Omega$  pull-up resistance to  $V_{CC1}$  and pin I/O2 has an integrated 14 k $\Omega$  pull-up resistance to  $V_{CC2}$ .
- [3] Pins C41 and C81 have an integrated 10 k $\Omega$  pull-up resistance to  $V_{CC1}$  and pins C42 and C82 have an integrated 10 k $\Omega$  pull-up resistance to  $V_{CC2}$ .
- [4] Pin I/OAUX has a 14 k $\Omega$  pull-up resistance to  $V_{DD}$ .

## 12. Timings

**Table 36. Timings** $V_{DD} = 3.3\text{ V}$ ;  $V_{DDA} = 3.3\text{ V}$ ;  $T_{amb} = 25\text{ }^{\circ}\text{C}$ ; unless otherwise specified.

Symbol	Parameter	Conditions	Min.	Typ.	Max.	Unit
<b>Timing for non-multiplexed bus</b>						
Read control; see <a href="#">Figure 4</a>						
$t_1$	$\overline{\text{RD}}$ high to $\overline{\text{CS}}$ low		10	-	-	ns
$t_2$	access time $\overline{\text{CS}}$ low to data out valid		-	-	50	ns
$t_3$	$\overline{\text{CS}}$ high to data out (high)		-	-	10	ns
Write control; see <a href="#">Figure 5</a> and <a href="#">6</a>						
$t_4$	data valid to end-of-write		10	-	-	ns
$t_5$	data hold time		10	-	-	ns
$t_6$	$\overline{\text{RD}}$ low to $\overline{\text{CS}}$ or $\overline{\text{WR}}$ low		10	-	-	ns
$t_7$	address stable to $\overline{\text{CS}}$ or $\overline{\text{WR}}$ high		10	-	-	ns
<b>Timing for bit CRED</b>						
Read operations in UART receive register; see <a href="#">Figure 9</a>						
$t_{W(\text{RD})}$	$\overline{\text{RD}}$ pulse width		10	-	-	ns
$t_{\text{RD}(\text{URR})}$	$\overline{\text{RD}}$ low to bit CRED = 1		$t_{W(\text{RD})} + 2T_{\text{cy}(\text{CLK})}$	-	$t_{W(\text{RD})} + 3T_{\text{cy}(\text{CLK})}$	ns
$t_{\text{SB}(\text{FE})}$	set bit time FE		10.5	-	-	ETU
$t_{\text{SB}(\text{RBF})}$	set time bit RBF		10.5	-	-	ETU
Write operations in UART transmit register; see <a href="#">Figure 10</a>						
$t_{W(\text{WR})}$	$\overline{\text{WR}}$ pulse width		10	-	-	ns
$t_{\text{WR}(\text{UTR})}$	$\overline{\text{WR}}$ low to I/O low		$t_{W(\text{WR})} + 2T_{\text{cy}(\text{CLK})}$	-	$t_{W(\text{WR})} + 3T_{\text{cy}(\text{CLK})}$	ns
Write operations in time-out configuration register; see <a href="#">Figure 11</a>						
$t_{W(\text{WR})}$	$\overline{\text{WR}}$ pulse width		10	-	-	ns



**Table 36. Timings**

$V_{DD} = 3.3\text{ V}$ ;  $V_{DDA} = 3.3\text{ V}$ ;  $T_{amb} = 25^{\circ}\text{C}$ ; unless otherwise specified.

Symbol	Parameter	Conditions	Min.	Typ.	Max.	Unit
$t_{WR(TOC)}$	WR low to bit CRED = 1	[1]	$\frac{1}{PSC}$	-	$\frac{2}{PSC}$	ETU
<b>Timing for multiplexed bus, only applicable for TDA8007BHL/C3</b>						
$T_{CY(XTAL1)}$	XTAL1 cyle time		50	-	-	ns
$t_{W(ALE)}$	ALE pulse width		20	-	-	ns
$t_{AVLL}$	address valid to ALE low		10	-	-	ns
$t_{(AL-RWL)}$	ALE low to $\overline{RD}$ or $\overline{WR}$ low		10	-	-	ns
$t_{W(RD)}$	$\overline{RD}$ pulse width	for register URR	$2T_{CY(XTAL1)}$	-	-	ns
		for other registers	10	-	-	ns
$t_{(RL-DV)}$	$\overline{RD}$ low to data read valid		-	-	50	ns
$t_{(RWH-AH)}$	$\overline{RD}$ or $\overline{WR}$ high to ALE high		10	-	-	ns
$t_{W(WR)}$	$\overline{WR}$ pulse width		10	-	-	ns
$t_{(DV-WL)}$	data write valid to $\overline{WR}$ low		10	-	-	ns

[1] PSC is the programmed prescaler value (31 or 32).

13. Application information

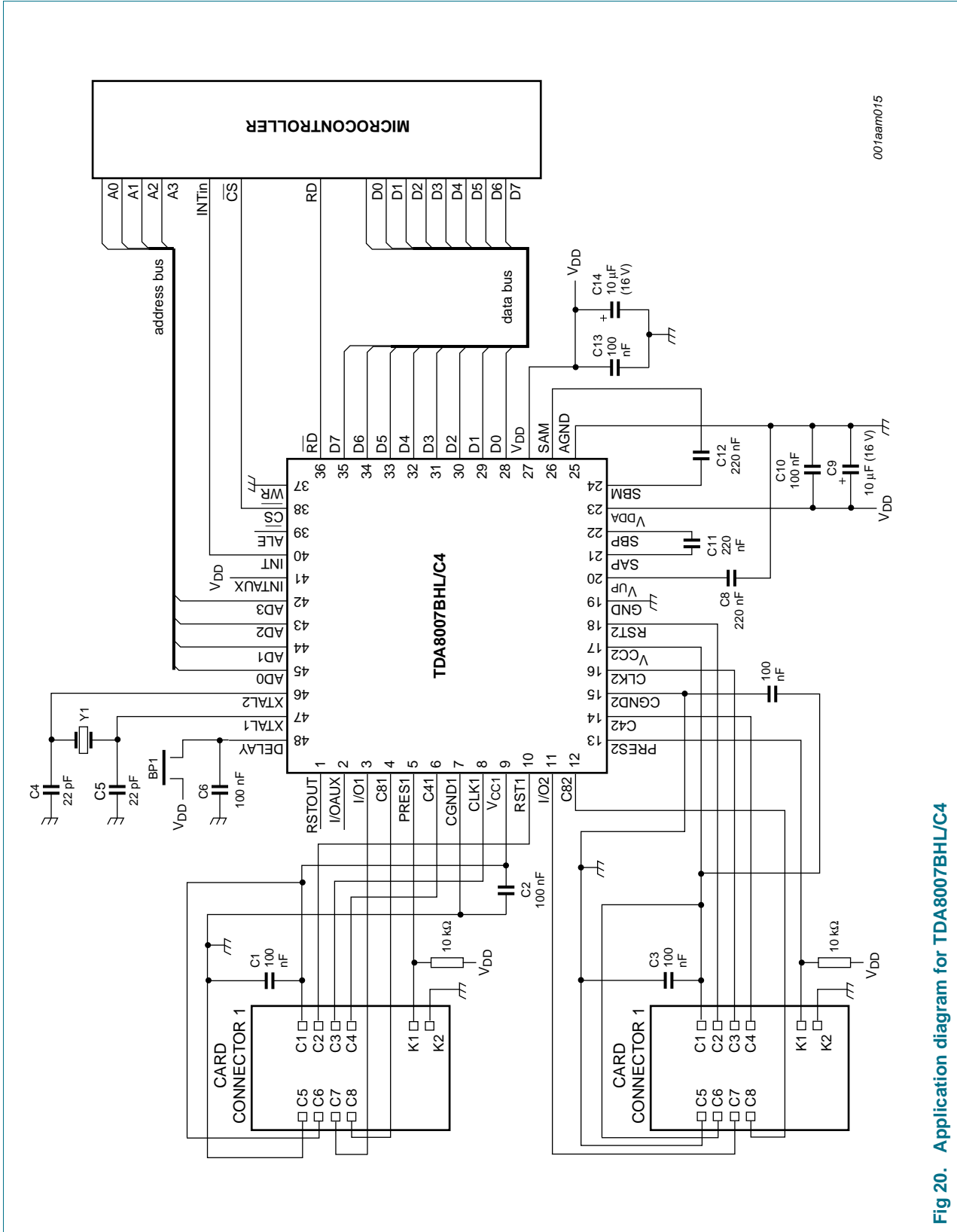

Fig 20. Application diagram for TDA8007BHL/C4

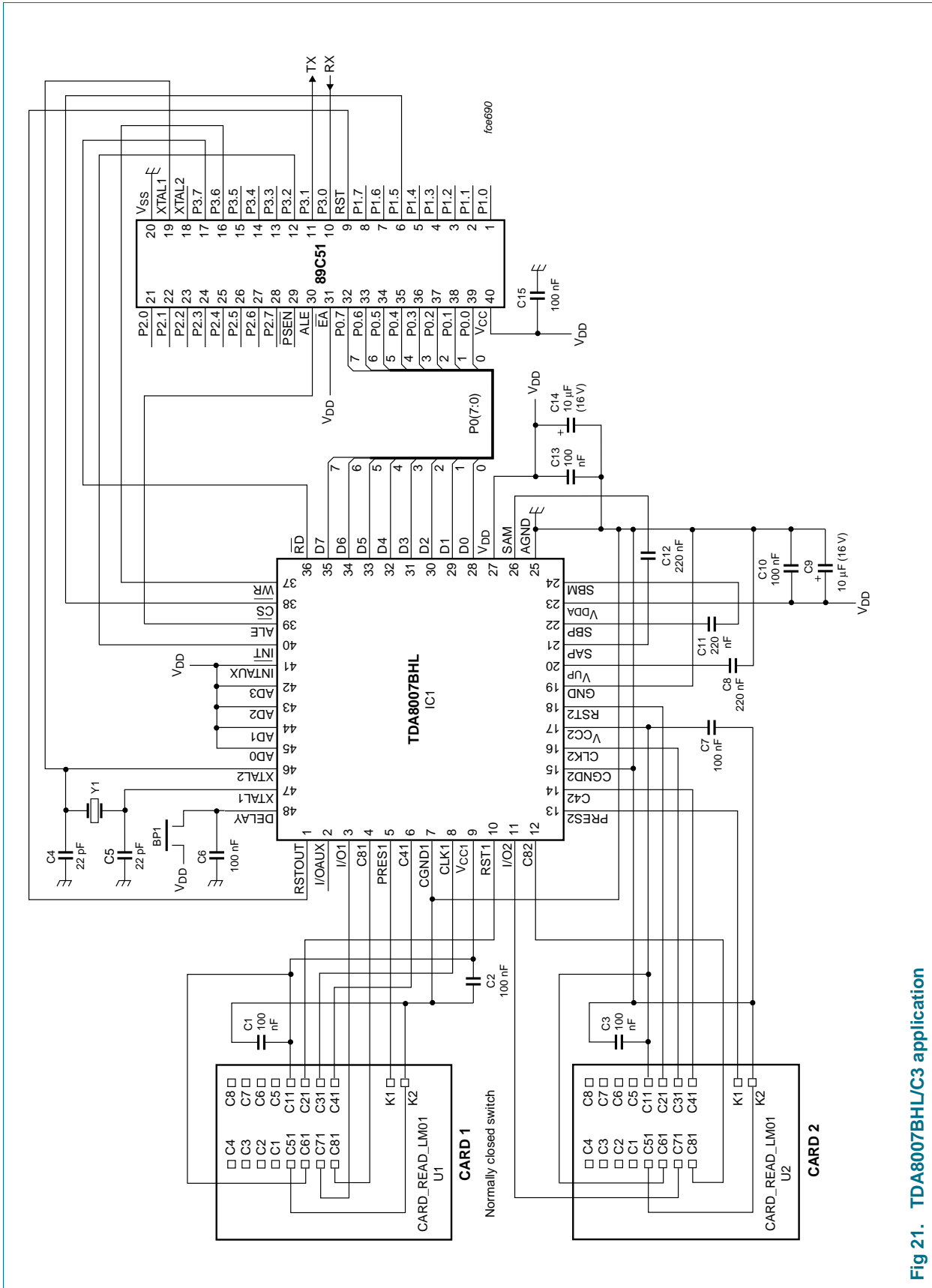

Fig 21. TDA8007BHL/C3 application

14. Package outline

LQFP48: plastic low profile quad flat package; 48 leads; body 7 x 7 x 1.4 mm

SOT313-2

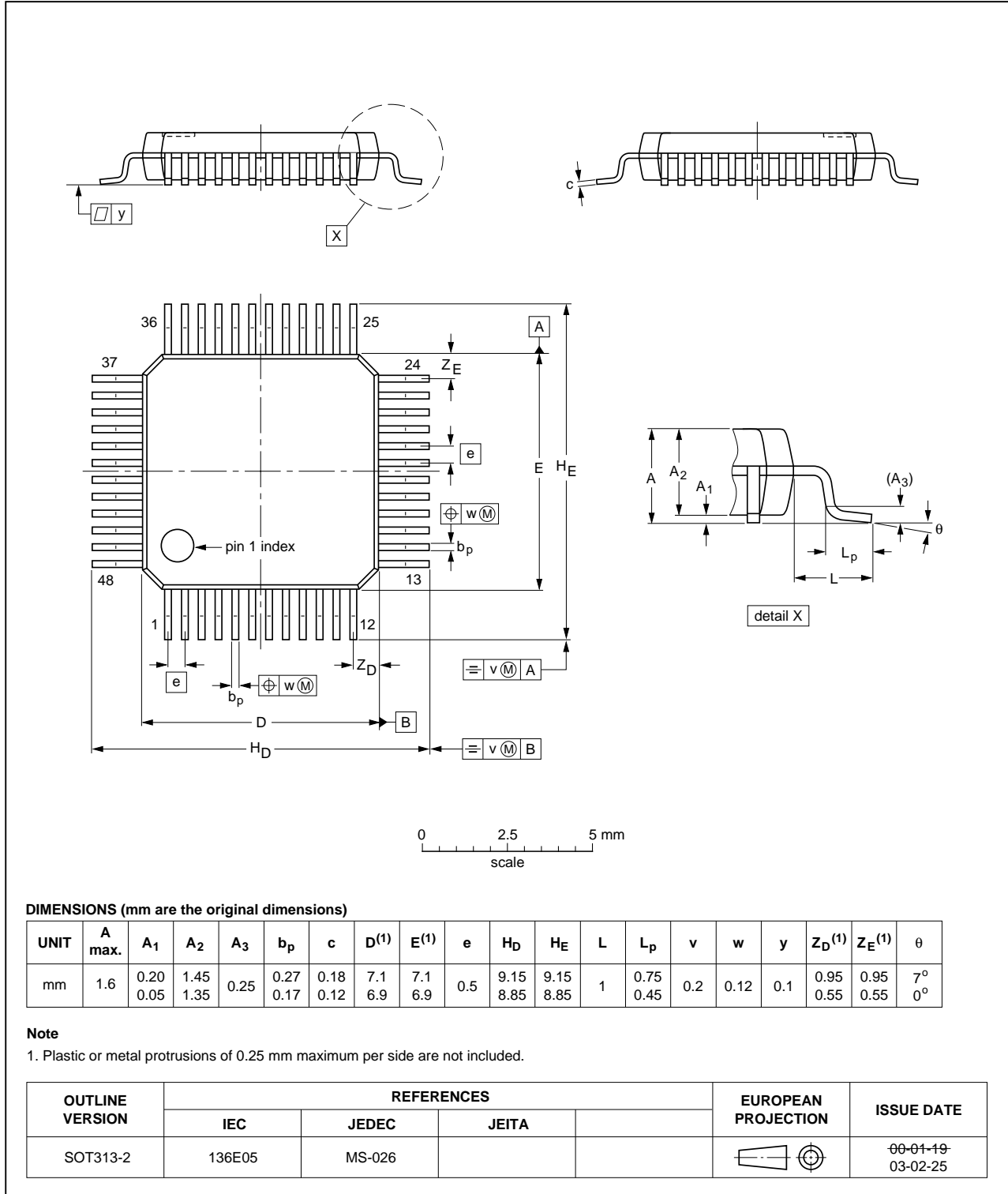

Fig 22. Package outline SOT313-2 (LQFP48)

## 15. Handling information

All input and output pins are protected against ElectroStatic Discharge (ESD) under normal handling. When handling Metal-Oxide Semiconductor (MOS) devices ensure that all normal precautions are taken as described in *JESD625-A*, *IEC 61340-5* or equivalent standards.

## 16. Soldering of SMD packages

This text provides a very brief insight into a complex technology. A more in-depth account of soldering ICs can be found in Application Note *AN10365 "Surface mount reflow soldering description"*.

### 16.1 Introduction to soldering

Soldering is one of the most common methods through which packages are attached to Printed Circuit Boards (PCBs), to form electrical circuits. The soldered joint provides both the mechanical and the electrical connection. There is no single soldering method that is ideal for all IC packages. Wave soldering is often preferred when through-hole and Surface Mount Devices (SMDs) are mixed on one printed wiring board; however, it is not suitable for fine pitch SMDs. Reflow soldering is ideal for the small pitches and high densities that come with increased miniaturization.

### 16.2 Wave and reflow soldering

Wave soldering is a joining technology in which the joints are made by solder coming from a standing wave of liquid solder. The wave soldering process is suitable for the following:

- Through-hole components
- Leaded or leadless SMDs, which are glued to the surface of the printed circuit board

Not all SMDs can be wave soldered. Packages with solder balls, and some leadless packages which have solder lands underneath the body, cannot be wave soldered. Also, leaded SMDs with leads having a pitch smaller than ~0.6 mm cannot be wave soldered, due to an increased probability of bridging.

The reflow soldering process involves applying solder paste to a board, followed by component placement and exposure to a temperature profile. Leaded packages, packages with solder balls, and leadless packages are all reflow solderable.

Key characteristics in both wave and reflow soldering are:

- Board specifications, including the board finish, solder masks and vias
- Package footprints, including solder thieves and orientation
- The moisture sensitivity level of the packages
- Package placement
- Inspection and repair
- Lead-free soldering versus SnPb soldering

### 16.3 Wave soldering

Key characteristics in wave soldering are:

- Process issues, such as application of adhesive and flux, clinching of leads, board transport, the solder wave parameters, and the time during which components are exposed to the wave
- Solder bath specifications, including temperature and impurities

### 16.4 Reflow soldering

Key characteristics in reflow soldering are:

- Lead-free versus SnPb soldering; note that a lead-free reflow process usually leads to higher minimum peak temperatures (see [Figure 23](#)) than a SnPb process, thus reducing the process window
- Solder paste printing issues including smearing, release, and adjusting the process window for a mix of large and small components on one board
- Reflow temperature profile; this profile includes preheat, reflow (in which the board is heated to the peak temperature) and cooling down. It is imperative that the peak temperature is high enough for the solder to make reliable solder joints (a solder paste characteristic). In addition, the peak temperature must be low enough that the packages and/or boards are not damaged. The peak temperature of the package depends on package thickness and volume and is classified in accordance with [Table 37](#) and [38](#)

**Table 37. SnPb eutectic process (from J-STD-020C)**

Package thickness (mm)	Package reflow temperature (°C)	
	Volume (mm <sup>3</sup> )	
	< 350	≥ 350
< 2.5	235	220
≥ 2.5	220	220

**Table 38. Lead-free process (from J-STD-020C)**

Package thickness (mm)	Package reflow temperature (°C)		
	Volume (mm <sup>3</sup> )		
	< 350	350 to 2000	> 2000
< 1.6	260	260	260
1.6 to 2.5	260	250	245
> 2.5	250	245	245

Moisture sensitivity precautions, as indicated on the packing, must be respected at all times.

Studies have shown that small packages reach higher temperatures during reflow soldering, see [Figure 23](#).

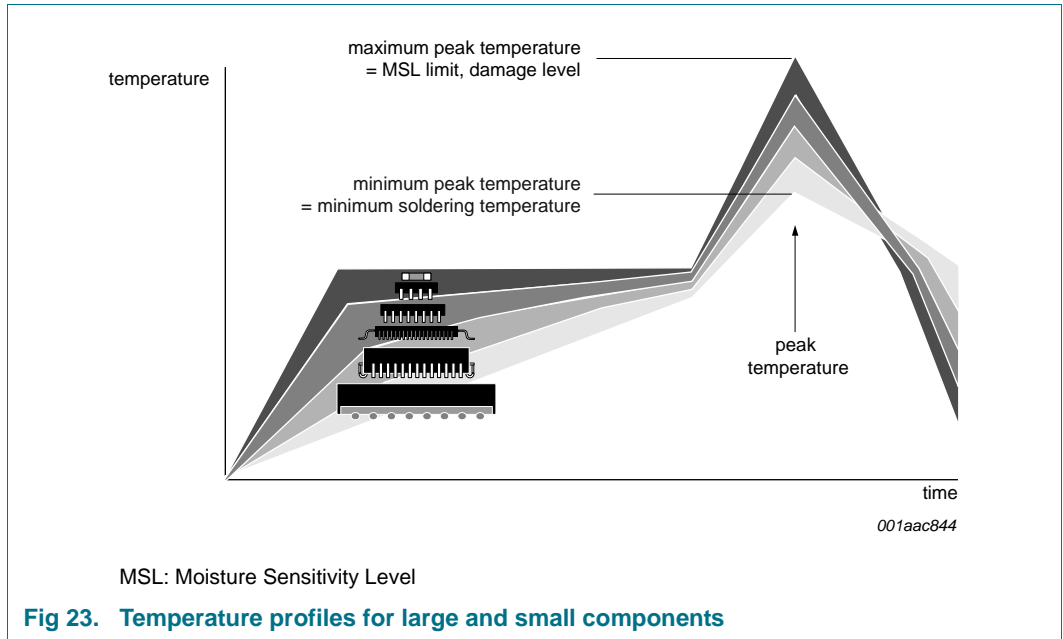

For further information on temperature profiles, refer to Application Note AN10365 “Surface mount reflow soldering description”.

## 17. Revision history

**Table 39. Revision history**

Document ID	Release date	Data sheet status	Change notice	Supersedes
TDA8007BHL v. 9.1	20120618	Product data sheet	-	TDA8007BHL v. 9
Modifications:	<ul style="list-style-type: none"> <li>• Small text correction</li> </ul>			
TDA8007BHL v. 9	20120612	Product data sheet	-	TDA8007BHL v. 8
Modifications:	<ul style="list-style-type: none"> <li>• <a href="#">Table 35 "Characteristics"</a>: Card presence inputs: pins PRES1 and PRES2: values updated</li> </ul>			
TDA8007BHL v. 8	20110111	Product data sheet	-	TDA8007B_7
Modifications:	<ul style="list-style-type: none"> <li>• Text changed to dedicate this data sheet to the C4 as well as the C3 variant.</li> </ul>			
TDA8007B_7	20100512	Product data sheet	-	TDA8007B_6
Modifications:	<ul style="list-style-type: none"> <li>• The format of this data sheet has been redesigned to comply with the new identity guidelines of NXP Semiconductors.</li> <li>• Legal texts have been adapted to the new company name where appropriate.</li> <li>• Text changed to dedicate this data sheet to the C4 variant.</li> </ul>			
TDA8007B_6	20030218	Product specification	-	TDA8007B_5
TDA8007B_5	20021115	Product specification	-	TDA8007B_4
TDA8007B_4	20020215	Product specification	-	TDA8007B_3
TDA8007B_3	20001109	Product specification	-	TDA8007B_2
TDA8007B_2	20000829	Product specification	-	TDA8007B_1
TDA8007B_1	19991111	Objective specification	-	-



## 18. Legal information

### 18.1 Data sheet status

Document status <sup>[1][2]</sup>	Product status <sup>[3]</sup>	Definition
Objective [short] data sheet	Development	This document contains data from the objective specification for product development.
Preliminary [short] data sheet	Qualification	This document contains data from the preliminary specification.
Product [short] data sheet	Production	This document contains the product specification.

[1] Please consult the most recently issued document before initiating or completing a design.

[2] The term 'short data sheet' is explained in section "Definitions".

[3] The product status of device(s) described in this document may have changed since this document was published and may differ in case of multiple devices. The latest product status information is available on the Internet at URL <http://www.nxp.com>.

### 18.2 Definitions

**Draft** — The document is a draft version only. The content is still under internal review and subject to formal approval, which may result in modifications or additions. NXP Semiconductors does not give any representations or warranties as to the accuracy or completeness of information included herein and shall have no liability for the consequences of use of such information.

**Short data sheet** — A short data sheet is an extract from a full data sheet with the same product type number(s) and title. A short data sheet is intended for quick reference only and should not be relied upon to contain detailed and full information. For detailed and full information see the relevant full data sheet, which is available on request via the local NXP Semiconductors sales office. In case of any inconsistency or conflict with the short data sheet, the full data sheet shall prevail.

**Product specification** — The information and data provided in a Product data sheet shall define the specification of the product as agreed between NXP Semiconductors and its customer, unless NXP Semiconductors and customer have explicitly agreed otherwise in writing. In no event however, shall an agreement be valid in which the NXP Semiconductors product is deemed to offer functions and qualities beyond those described in the Product data sheet.

### 18.3 Disclaimers

**Limited warranty and liability** — Information in this document is believed to be accurate and reliable. However, NXP Semiconductors does not give any representations or warranties, expressed or implied, as to the accuracy or completeness of such information and shall have no liability for the consequences of use of such information. NXP Semiconductors takes no responsibility for the content in this document if provided by an information source outside of NXP Semiconductors.

In no event shall NXP Semiconductors be liable for any indirect, incidental, punitive, special or consequential damages (including - without limitation - lost profits, lost savings, business interruption, costs related to the removal or replacement of any products or rework charges) whether or not such damages are based on tort (including negligence), warranty, breach of contract or any other legal theory.

Notwithstanding any damages that customer might incur for any reason whatsoever, NXP Semiconductors' aggregate and cumulative liability towards customer for the products described herein shall be limited in accordance with the *Terms and conditions of commercial sale* of NXP Semiconductors.

**Right to make changes** — NXP Semiconductors reserves the right to make changes to information published in this document, including without limitation specifications and product descriptions, at any time and without notice. This document supersedes and replaces all information supplied prior to the publication hereof.

**Suitability for use** — NXP Semiconductors products are not designed, authorized or warranted to be suitable for use in life support, life-critical or safety-critical systems or equipment, nor in applications where failure or malfunction of an NXP Semiconductors product can reasonably be expected to result in personal injury, death or severe property or environmental damage. NXP Semiconductors and its suppliers accept no liability for inclusion and/or use of NXP Semiconductors products in such equipment or applications and therefore such inclusion and/or use is at the customer's own risk.

**Applications** — Applications that are described herein for any of these products are for illustrative purposes only. NXP Semiconductors makes no representation or warranty that such applications will be suitable for the specified use without further testing or modification.

Customers are responsible for the design and operation of their applications and products using NXP Semiconductors products, and NXP Semiconductors accepts no liability for any assistance with applications or customer product design. It is customer's sole responsibility to determine whether the NXP Semiconductors product is suitable and fit for the customer's applications and products planned, as well as for the planned application and use of customer's third party customer(s). Customers should provide appropriate design and operating safeguards to minimize the risks associated with their applications and products.

NXP Semiconductors does not accept any liability related to any default, damage, costs or problem which is based on any weakness or default in the customer's applications or products, or the application or use by customer's third party customer(s). Customer is responsible for doing all necessary testing for the customer's applications and products using NXP Semiconductors products in order to avoid a default of the applications and the products or of the application or use by customer's third party customer(s). NXP does not accept any liability in this respect.

**Limiting values** — Stress above one or more limiting values (as defined in the Absolute Maximum Ratings System of IEC 60134) will cause permanent damage to the device. Limiting values are stress ratings only and (proper) operation of the device at these or any other conditions above those given in the Recommended operating conditions section (if present) or the Characteristics sections of this document is not warranted. Constant or repeated exposure to limiting values will permanently and irreversibly affect the quality and reliability of the device.

**Terms and conditions of commercial sale** — NXP Semiconductors products are sold subject to the general terms and conditions of commercial sale, as published at <http://www.nxp.com/profile/terms>, unless otherwise agreed in a valid written individual agreement. In case an individual agreement is concluded only the terms and conditions of the respective agreement shall apply. NXP Semiconductors hereby expressly objects to applying the customer's general terms and conditions with regard to the purchase of NXP Semiconductors products by customer.

**No offer to sell or license** — Nothing in this document may be interpreted or construed as an offer to sell products that is open for acceptance or the grant, conveyance or implication of any license under any copyrights, patents or other industrial or intellectual property rights.

**Export control** — This document as well as the item(s) described herein may be subject to export control regulations. Export might require a prior authorization from competent authorities.

**Quick reference data** — The Quick reference data is an extract of the product data given in the Limiting values and Characteristics sections of this document, and as such is not complete, exhaustive or legally binding.

**Non-automotive qualified products** — Unless this data sheet expressly states that this specific NXP Semiconductors product is automotive qualified, the product is not suitable for automotive use. It is neither qualified nor tested in accordance with automotive testing or application requirements. NXP Semiconductors accepts no liability for inclusion and/or use of non-automotive qualified products in automotive equipment or applications.

In the event that customer uses the product for design-in and use in automotive applications to automotive specifications and standards, customer (a) shall use the product without NXP Semiconductors' warranty of the

product for such automotive applications, use and specifications, and (b) whenever customer uses the product for automotive applications beyond NXP Semiconductors' specifications such use shall be solely at customer's own risk, and (c) customer fully indemnifies NXP Semiconductors for any liability, damages or failed product claims resulting from customer design and use of the product for automotive applications beyond NXP Semiconductors' standard warranty and NXP Semiconductors' product specifications.

**Translations** — A non-English (translated) version of a document is for reference only. The English version shall prevail in case of any discrepancy between the translated and English versions.

## 18.4 Trademarks

Notice: All referenced brands, product names, service names and trademarks are the property of their respective owners.

## 19. Contact information

For more information, please visit: <http://www.nxp.com>

For sales office addresses, please send an email to: [salesaddresses@nxp.com](mailto:salesaddresses@nxp.com)

20. Contents

<b>1</b>	<b>General description</b> . . . . .	<b>1</b>	<b>16</b>	<b>Soldering of SMD packages</b> . . . . .	<b>45</b>
<b>2</b>	<b>Features and benefits</b> . . . . .	<b>1</b>	16.1	Introduction to soldering . . . . .	45
<b>3</b>	<b>Applications</b> . . . . .	<b>2</b>	16.2	Wave and reflow soldering . . . . .	45
<b>4</b>	<b>Quick reference data</b> . . . . .	<b>2</b>	16.3	Wave soldering . . . . .	46
<b>5</b>	<b>Ordering information</b> . . . . .	<b>3</b>	16.4	Reflow soldering . . . . .	46
<b>6</b>	<b>Block diagram</b> . . . . .	<b>4</b>	<b>17</b>	<b>Revision history</b> . . . . .	<b>48</b>
<b>7</b>	<b>Pinning information</b> . . . . .	<b>5</b>	<b>18</b>	<b>Legal information</b> . . . . .	<b>49</b>
7.1	Pinning . . . . .	5	18.1	Data sheet status . . . . .	49
7.2	Pin description . . . . .	5	18.2	Definitions . . . . .	49
<b>8</b>	<b>Functional description</b> . . . . .	<b>7</b>	18.3	Disclaimers . . . . .	49
8.1	Interface control . . . . .	7	18.4	Trademarks . . . . .	50
8.1.1	Non-Multiplexed configuration . . . . .	7	<b>19</b>	<b>Contact information</b> . . . . .	<b>50</b>
8.1.2	Multiplexed configuration . . . . .	9	<b>20</b>	<b>Contents</b> . . . . .	<b>51</b>
8.2	Control registers . . . . .	10			
8.2.1	General registers . . . . .	13			
8.2.1.1	Card select register . . . . .	13			
8.2.1.2	Hardware status register . . . . .	13			
8.2.1.3	Time-out registers . . . . .	14			
8.2.1.4	Time-out configuration register . . . . .	15			
8.2.2	ISO UART registers . . . . .	17			
8.2.2.1	UART Transmit Register (UTR) . . . . .	17			
8.2.2.2	UART Receive Register (URR) . . . . .	17			
8.2.2.3	Mixed Status Register (MSR) . . . . .	18			
8.2.2.4	FIFO Control Registers (FSR) . . . . .	22			
8.2.2.5	UART Status Register (USR) . . . . .	22			
8.2.3	Card registers . . . . .	24			
8.2.3.1	Programmable Divider Register (PDR) . . . . .	24			
8.2.3.2	UART Configuration Registers (UCR) 2 . . . . .	24			
8.2.3.3	Guard Time Registers (GTR) . . . . .	26			
8.2.3.4	UART Configuration Registers (UCR) 1 . . . . .	26			
8.2.3.5	Clock Configuration Registers (CCR) . . . . .	27			
8.2.3.6	Power Control Registers (PCR) . . . . .	28			
8.2.4	register summary . . . . .	30			
8.3	Supply . . . . .	31			
8.4	Step up converter . . . . .	32			
8.5	ISO 7816 security . . . . .	32			
8.6	Activation sequence . . . . .	33			
8.7	Deactivation sequence . . . . .	34			
<b>9</b>	<b>Limiting values</b> . . . . .	<b>35</b>			
<b>10</b>	<b>Thermal characteristics</b> . . . . .	<b>35</b>			
<b>11</b>	<b>Characteristics</b> . . . . .	<b>35</b>			
<b>12</b>	<b>Timings</b> . . . . .	<b>40</b>			
<b>13</b>	<b>Application information</b> . . . . .	<b>42</b>			
<b>14</b>	<b>Package outline</b> . . . . .	<b>44</b>			
<b>15</b>	<b>Handling information</b> . . . . .	<b>45</b>			

Please be aware that important notices concerning this document and the product(s) described herein, have been included in section 'Legal information'.

© NXP B.V. 2012. All rights reserved.

For more information, please visit: <http://www.nxp.com>  
 For sales office addresses, please send an email to: [salesaddresses@nxp.com](mailto:salesaddresses@nxp.com)

Date of release: 18 June 2012  
 Document identifier: TDA8007BHL