

GTL2002

2-bit bidirectional low voltage translator

Rev. 07 — 2 July 2009

Product data sheet

1. General description

The Gunning Transceiver Logic - Transceiver Voltage Clamps (GTL-TVC) provide high-speed voltage translation with low ON-state resistance and minimal propagation delay. The GTL2002 provides 2 NMOS pass transistors (Sn and Dn) with a common gate (GREF) and a reference transistor (SREF and DREF). The device allows bidirectional voltage translations between 1.0 V and 5.0 V without use of a direction pin.

When the Sn or Dn port is LOW the clamp is in the ON-state and a low resistance connection exists between the Sn and Dn ports. Assuming the higher voltage is on the Dn port, when the Dn port is HIGH, the voltage on the Sn port is limited to the voltage set by the reference transistor (SREF). When the Sn port is HIGH, the Dn port is pulled to V_{CC} by the pull-up resistors. This functionality allows a seamless translation between higher and lower voltages selected by the user, without the need for directional control.

All transistors have the same electrical characteristics and there is minimal deviation from one output to another in voltage or propagation delay. This is a benefit over discrete transistor voltage translation solutions, since the fabrication of the transistors is symmetrical. Because all transistors in the device are identical, SREF and DREF can be located on any of the other two matched Sn/Dn transistors, allowing for easier board layout. The translator's transistors provide excellent ESD protection to lower voltage devices and at the same time protect less ESD-resistant devices.

2. Features

- 2-bit bidirectional low voltage translator
- Allows voltage level translation between 1.0 V, 1.2 V, 1.5 V, 1.8 V, 2.5 V, 3.3 V and 5 V buses, which allows direct interface with GTL, GTL+, LVTTTL/TTL and 5 V CMOS levels
- Provides bidirectional voltage translation with no direction pin
- Low 6.5Ω ON-state resistance (R_{on}) between input and output pins (Sn/Dn)
- Supports hot insertion
- No power supply required; will not latch up
- 5 V tolerant inputs
- Low standby current
- Flow-through pinout for ease of printed-circuit board trace routing
- ESD protection exceeds 2000 V HBM per JESD22-A114, 150 V MM per JESD22-A115, and 1000 V CDM per JESD22-C101
- Packages offered: SO8, TSSOP8 (MSOP8), VSSOP8, XQFN8U

3. Applications

- Any application that requires bidirectional or unidirectional voltage level translation from any voltage between 1.0 V and 5.0 V to any voltage between 1.0 V and 5.0 V
- The open-drain construction with no direction pin is ideal for bidirectional low voltage (e.g., 1.0 V, 1.2 V, 1.5 V, or 1.8 V) processor I²C-bus port translation to the normal 3.3 V or 5.0 V I²C-bus signal levels or GTL/GTL+ translation to LVTTTL/TTL signal levels.

4. Ordering information

Table 1. Ordering information

Type number	Package		
	Name	Description	Version
GTL2002D	SO8	plastic small outline package; 8 leads; body width 3.9 mm	SOT96-1
GTL2002DP	TSSOP8 ^[1]	plastic thin shrink small outline package; 8 leads; body width 3 mm	SOT505-1
GTL2002DP/Q900 ^[2]	TSSOP8 ^[1]	plastic thin shrink small outline package; 8 leads; body width 3 mm	SOT505-1
GTL2002DC	VSSOP8	plastic very thin shrink small outline package; 8 leads; body width 2.3 mm	SOT765-1
GTL2002GM	XQFN8U	plastic extremely thin quad flat package; no leads; 8 terminals; UTLP based; body 1.6 × 1.6 × 0.5 mm	SOT902-1

[1] Also known as MSOP8.

[2] GTL2002DP/Q900 is AEC-Q100 compliant. Contact i2c.support@nxp.com for PPAP.

4.1 Ordering options

Table 2. Ordering options

Type number	Topside mark	Temperature range
GTL2002D	GTL2002	T _{amb} = -40 °C to +85 °C
GTL2002DP	2002	T _{amb} = -40 °C to +85 °C
GTL2002DP/Q900	2002	T _{amb} = -40 °C to +85 °C
GTL2002DC	2002	T _{amb} = -40 °C to +85 °C
GTL2002GM	G2X ^[1]	T _{amb} = -40 °C to +85 °C

[1] 'X' will change based on date code.

5. Functional diagram

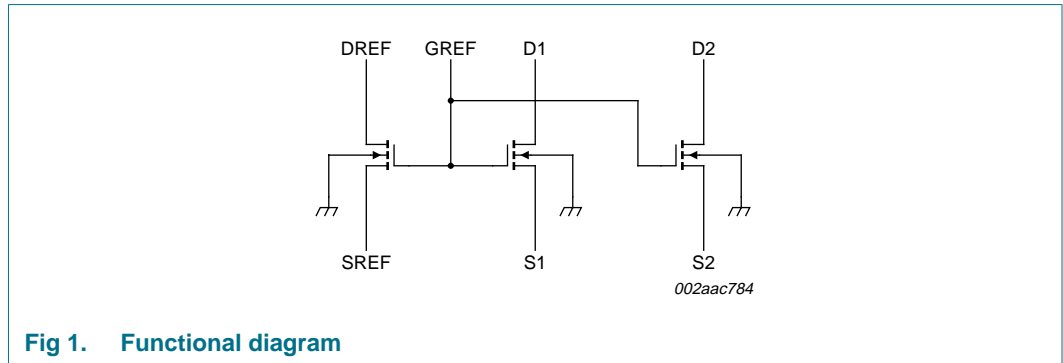

Fig 1. Functional diagram

6. Pinning information

6.1 Pinning

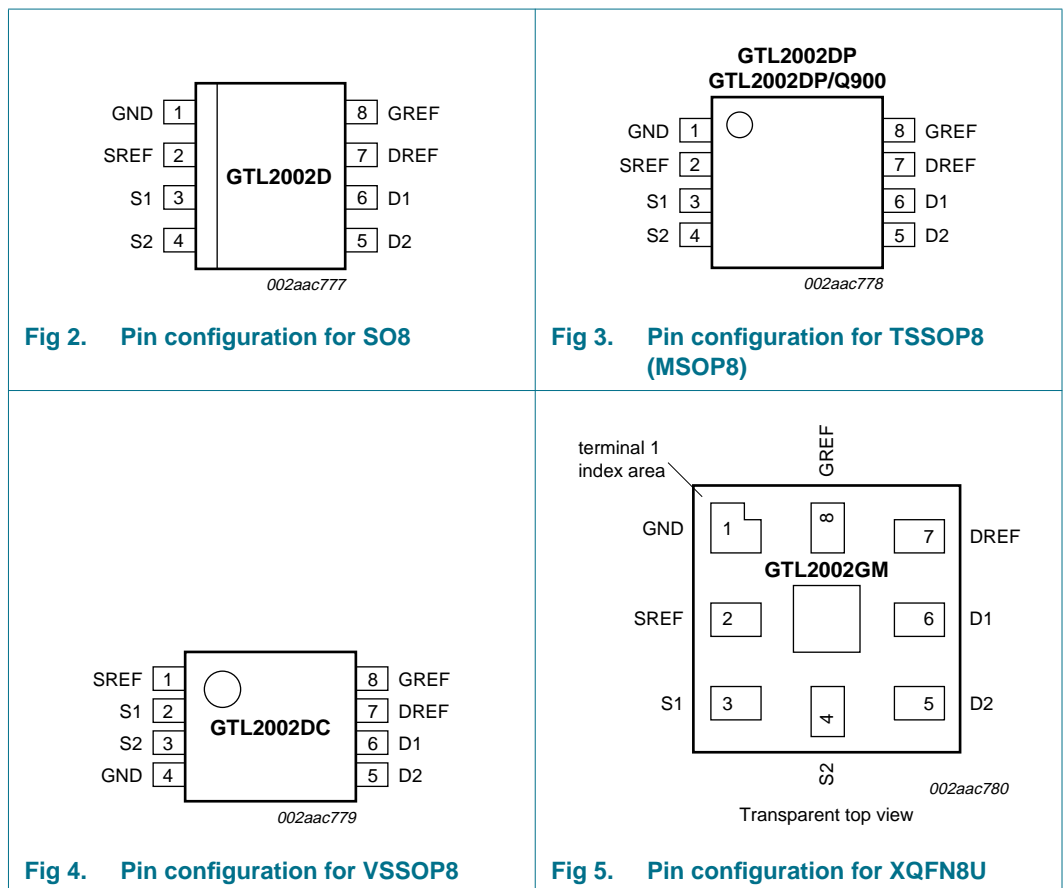

Fig 2. Pin configuration for SO8

Fig 3. Pin configuration for TSSOP8 (MSOP8)

Fig 4. Pin configuration for VSSOP8

Fig 5. Pin configuration for XQFN8U

6.2 Pin description

Table 3. Pin description

Symbol	Pin		Description
	SO8, TSSOP8, XQFN8U	VSSOP8	
GND	1	4	ground (0 V)
SREF	2	1	source of reference transistor
S1	3	2	port S1
S2	4	3	port S2
D2	5	5	port D2
D1	6	6	port D1
DREF	7	7	drain of reference transistor
GREF	8	8	gate of reference transistor

7. Functional description

Refer to [Figure 1 “Functional diagram”](#).

7.1 Function selection

Table 4. Function selection, HIGH to LOW translation

Assuming D_n is at the higher voltage level.

H = HIGH voltage level; L = LOW voltage level; X = Don't care.

GREF ^[1]	DREF	SREF	Input D_n	Output S_n	Transistor
H	H	0 V	X	X	off
H	H	V_{TT} ^[4]	H	V_{TT} ^{[2][4]}	on
H	H	V_{TT} ^[4]	L	L ^[3]	on
L	L	$0\text{ V} - V_{TT}$ ^[4]	X	X	off

[1] GREF should be at least 1.5 V higher than SREF for best translator operation.

[2] S_n is not pulled up or pulled down.

[3] S_n follows the D_n input LOW.

[4] V_{TT} is equal to the SREF voltage.

Table 5. Function selection, LOW to HIGH translation

Assuming D_n is at the higher voltage level.

H = HIGH voltage level; L = LOW voltage level; X = Don't care.

GREF ^[1]	DREF	SREF	Input S_n	Output D_n	Transistor
H	H	0 V	X	X	off
H	H	V_{TT} ^[4]	V_{TT} ^[4]	H ^[2]	nearly off
H	H	V_{TT} ^[4]	L	L ^[3]	on
L	L	$0\text{ V} - V_{TT}$ ^[4]	X	X	off

[1] GREF should be at least 1.5 V higher than SREF for best translator operation.

[2] D_n is pulled up to V_{CC} through an external resistor.

[3] D_n follows the S_n input LOW.

[4] V_{TT} is equal to the SREF voltage.

8. Application design-in information

8.1 Bidirectional translation

For the bidirectional clamping configuration, higher voltage to lower voltage or lower voltage to higher voltage, the GREF input must be connected to DREF and both pins pulled to HIGH side V_{CC} through a pull-up resistor (typically 200 k Ω). A filter capacitor on DREF is recommended. The processor output can be totem pole or open-drain (pull-up resistors may be required) and the chip set output can be totem pole or open-drain (pull-up resistors are required to pull the Dn outputs to V_{CC}). However, if either output is totem pole, data must be unidirectional or the outputs must be 3-stateable and the outputs must be controlled by some direction control mechanism to prevent HIGH-to-LOW contentions in either direction. If both outputs are open-drain, no direction control is needed. The opposite side of the reference transistor (SREF) is connected to the processor core power supply voltage. When DREF is connected through a 200 k Ω resistor to a 3.3 V to 5.5 V V_{CC} supply and SREF is set between 1.0 V to ($V_{CC} - 1.5$ V), the output of each Sn has a maximum output voltage equal to SREF and the output of each Dn has a maximum output voltage equal to V_{CC} .

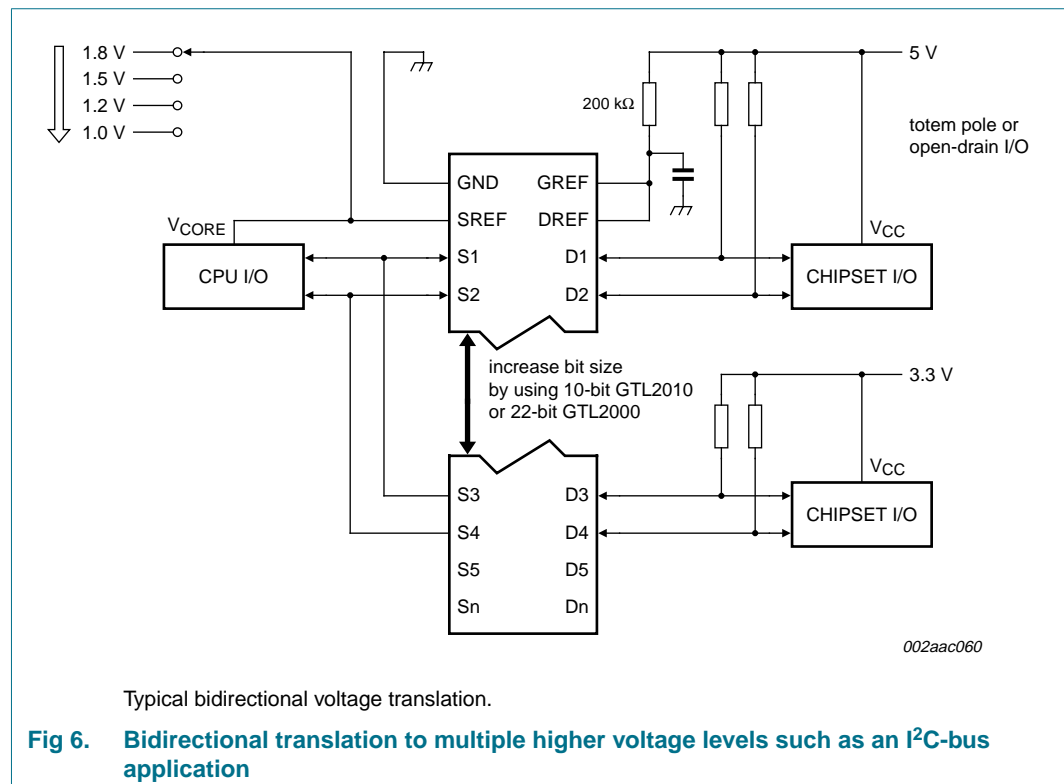

8.2 Unidirectional down translation

For unidirectional clamping, higher voltage to lower voltage, the GREF input must be connected to DREF and both pins pulled to the higher side V_{CC} through a pull-up resistor (typically 200 k Ω). A filter capacitor on DREF is recommended. Pull-up resistors are required if the chip set I/O are open-drain. The opposite side of the reference transistor (SREF) is connected to the processor core supply voltage. When DREF is connected through a 200 k Ω resistor to a 3.3 V to 5.5 V V_{CC} supply and SREF is set between 1.0 V to ($V_{CC} - 1.5$ V), the output of each S_n has a maximum output voltage equal to SREF.

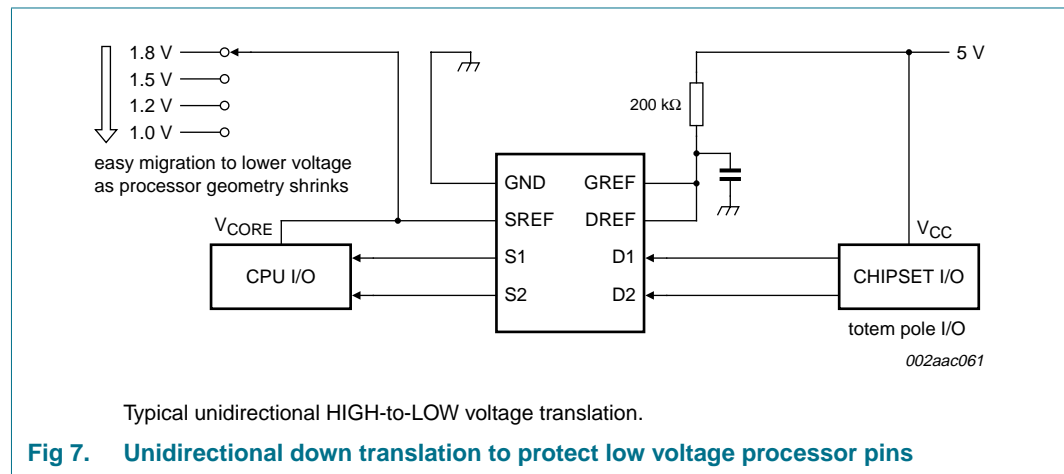

8.3 Unidirectional up translation

For unidirectional up translation, lower voltage to higher voltage, the reference transistor is connected the same as for a down translation. A pull-up resistor is required on the higher voltage side (D_n or S_n) to get the full HIGH level, since the GTL-TV C device will only pass the reference source (SREF) voltage as a HIGH when doing an up translation. The driver on the lower voltage side only needs pull-up resistors if it is open-drain.

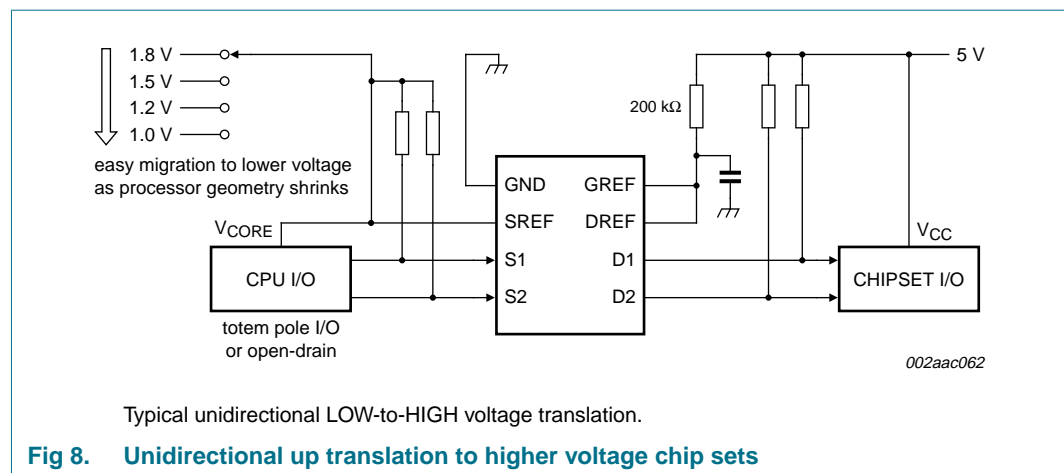

8.4 Sizing pull-up resistor

The pull-up resistor value needs to limit the current through the pass transistor when it is in the ON state to about 15 mA. This will guarantee a pass voltage of 260 mV to 350 mV. If the current through the pass transistor is higher than 15 mA, the pass voltage will also be higher in the ON state. To set the current through each pass transistor at 15 mA, the pull-up resistor value is calculated as shown in [Equation 1](#):

$$resistor\ value\ (\Omega) = \frac{pull\text{-}up\ voltage\ (V) - 0.35\ V}{0.015\ A} \tag{1}$$

[Table 6](#) summarizes resistor values for various reference voltages and currents at 15 mA and also at 10 mA and 3 mA. The resistor value shown in the +10 % column or a larger value should be used to ensure that the pass voltage of the transistor would be 350 mV or less. The external driver must be able to sink the total current from the resistors on both sides of the GTL-TVC device at 0.175 V, although the 15 mA only applies to current flowing through the GTL-TVC device. See application note *AN10145, "Bidirectional low voltage translators"* for more information.

Table 6. Pull-up resistor values

Voltage	Pull-up resistor value (Ω) ^[1]					
	15 mA ^[2]		10 mA ^[2]		3 mA ^[2]	
	Nominal	+ 10 % ^[3]	Nominal	+ 10 % ^[3]	Nominal	+ 10 % ^[3]
5.0 V	310	341	465	512	1550	1705
3.3 V	197	217	295	325	983	1082
2.5 V	143	158	215	237	717	788
1.8 V	97	106	145	160	483	532
1.5 V	77	85	115	127	383	422
1.2 V	57	63	85	94	283	312

[1] Calculated for V_{OL} = 0.35 V.

[2] Assumes output driver V_{OL} = 0.175 V at stated current.

[3] + 10 % to compensate for V_{DD} range and resistor tolerance.

9. Limiting values

Table 7. Limiting values^[1]

In accordance with the Absolute Maximum Rating System (IEC 60134).

Symbol	Parameter	Conditions	Min	Max	Unit
V _{SREF}	voltage on pin SREF		[2] -0.5	+7.0	V
V _{DREF}	voltage on pin DREF		[2] -0.5	+7.0	V
V _{GREF}	voltage on pin GREF		[2] -0.5	+7.0	V
V _{Sn}	voltage on port Sn		[2] -0.5	+7.0	V
V _{Dn}	voltage on port Dn		[2] -0.5	+7.0	V
I _{REFK}	diode current on reference pins	V _I < 0 V	-	-50	mA
I _{SK}	diode current port Sn	V _I < 0 V	-	-50	mA
I _{DK}	diode current port Dn	V _I < 0 V	-	-50	mA
I _{max}	clamp current per channel	channel in ON state	-	±128	mA
T _{stg}	storage temperature		-65	+150	°C

[1] The performance capability of a high-performance integrated circuit in conjunction with its thermal environment can create junction temperature which are detrimental to reliability. The maximum junction temperature of this integrated circuit should not exceed 150 °C.

[2] The input and output negative voltage ratings may be exceeded if the input and output clamp current ratings are observed.

10. Recommended operating conditions

Table 8. Recommended operating conditions

Symbol	Parameter	Conditions	Min	Max	Unit
V _{I/O}	voltage on an input/output pin	Sn, Dn	0	5.5	V
V _{SREF}	voltage on pin SREF		[1] 0	5.5	V
V _{DREF}	voltage on pin DREF		0	5.5	V
V _{GREF}	voltage on pin GREF		0	5.5	V
I _{PASS}	pass transistor current		-	64	mA
T _{amb}	ambient temperature	operating in free air	-40	+85	°C

[1] V_{SREF} ≤ V_{DREF} - 1.5 V for best results in level shifting applications.

11. Static characteristics

Table 9. Static characteristics

$T_{amb} = -40\text{ }^{\circ}\text{C}$ to $+85\text{ }^{\circ}\text{C}$, unless otherwise specified.

Symbol	Parameter	Conditions	Min	Typ ^[1]	Max	Unit
V_{OL}	LOW-level output voltage	$V_{DD} = 3.0\text{ V}$; $V_{SREF} = 1.365\text{ V}$; V_{Sn} or $V_{Dn} = 0.175\text{ V}$; $I_{clamp} = 15.2\text{ mA}$	-	260	350	mV
V_{IK}	input clamping voltage	$I_I = -18\text{ mA}$; $V_{GREF} = 0\text{ V}$	-	-	-1.2	V
$I_{LI(gate)}$	gate input leakage current	$V_I = 5\text{ V}$; $V_{GREF} = 0\text{ V}$	-	-	5	μA
C_{ig}	input capacitance at gate	pin GREF; $V_I = 3\text{ V}$ or 0 V	-	19.4	-	pF
$C_{io(off)}$	off-state input/output capacitance	$V_O = 3\text{ V}$ or 0 V ; $V_{GREF} = 0\text{ V}$	[2]	7.4	-	pF
$C_{io(on)}$	on-state input/output capacitance	$V_O = 3\text{ V}$ or 0 V ; $V_{GREF} = 3\text{ V}$	[2]	18.6	-	pF
R_{on}	ON-state resistance	$V_I = 0\text{ V}$; $I_O = 64\text{ mA}$	[3]			
		$V_{GREF} = 4.5\text{ V}$	-	3.5	5	Ω
		$V_{GREF} = 3\text{ V}$	-	4.4	7	Ω
		$V_{GREF} = 2.3\text{ V}$	-	5.5	9	Ω
		$V_{GREF} = 1.5\text{ V}$	-	67	105	Ω
		$V_I = 0\text{ V}$; $I_O = 30\text{ mA}$; $V_{GREF} = 1.5\text{ V}$	[3]	9	15	Ω
		$V_I = 2.4\text{ V}$; $I_O = 15\text{ mA}$; $V_{GREF} = 4.5\text{ V}$	[3]	7	10	Ω
		$V_I = 2.4\text{ V}$; $I_O = 15\text{ mA}$; $V_{GREF} = 3\text{ V}$	[3]	58	80	Ω
		$V_I = 1.7\text{ V}$; $I_O = 15\text{ mA}$; $V_{GREF} = 2.3\text{ V}$	[3]	50	70	Ω

[1] All typical values are measured at $T_{amb} = 25\text{ }^{\circ}\text{C}$.

[2] $C_{io(on)}$ maximum of 30 pF and $C_{io(off)}$ maximum of 15 pF is guaranteed by design.

[3] Measured by the voltage drop between the Sn and the Dn terminals at the indicated current through the switch. ON-state resistance is determined by the lowest voltage of the two (Sn or Dn) terminals.

12. Dynamic characteristics

12.1 Dynamic characteristics for translator-type application

Table 10. Dynamic characteristics for translator-type application

$T_{amb} = -40\text{ }^{\circ}\text{C}$ to $+85\text{ }^{\circ}\text{C}$; $V_{ref} = 1.365\text{ V}$ to 1.635 V ; $V_{DD1} = 3.0\text{ V}$ to 3.6 V ; $V_{DD2} = 2.36\text{ V}$ to 2.64 V ; $GND = 0\text{ V}$; $t_r = t_f \leq 3.0\text{ ns}$. Refer to [Figure 11](#).

Symbol	Parameter	Conditions	Min	Typ ^[1]	Max	Unit
t_{PLH}	LOW to HIGH propagation delay	Sn to Dn; Dn to Sn	[2] 0.5	1.5	5.5	ns
t_{PHL}	HIGH to LOW propagation delay	Sn to Dn; Dn to Sn	[2] 0.5	1.5	5.5	ns

[1] All typical values are measured at $V_{DD1} = 3.3\text{ V}$, $V_{DD2} = 2.5\text{ V}$; $V_{ref} = 1.5\text{ V}$ and $T_{amb} = 25\text{ }^{\circ}\text{C}$.

[2] Propagation delay guaranteed by characterization.

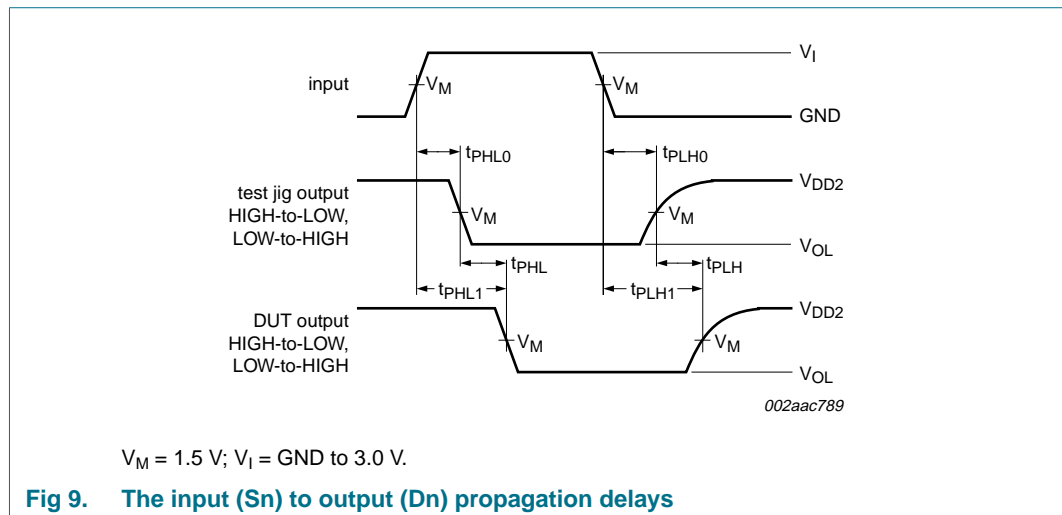

Fig 9. The input (Sn) to output (Dn) propagation delays

12.2 Dynamic characteristics for CBT-type application

Table 11. Dynamic characteristics for CBT-type application

$T_{amb} = -40\text{ }^{\circ}\text{C to }+85\text{ }^{\circ}\text{C}$; $V_{GREF} = 5\text{ V} \pm 0.5\text{ V}$; $GND = 0\text{ V}$; $t_r = t_f \leq 3.0\text{ ns}$; $C_L = 50\text{ pF}$.

Symbol	Parameter	Conditions	Min	Typ	Max	Unit
t_{PD}	propagation delay	[1]	-	-	250	ps

[1] This parameter is warranted by the ON-state resistance at $GREF = 4.5\text{ V}$, but is not directly production tested. The propagation delay is based on the RC time constant of the typical ON-state resistance of the switch and a load capacitance of 50 pF , when driven by an ideal voltage source (zero output impedance).

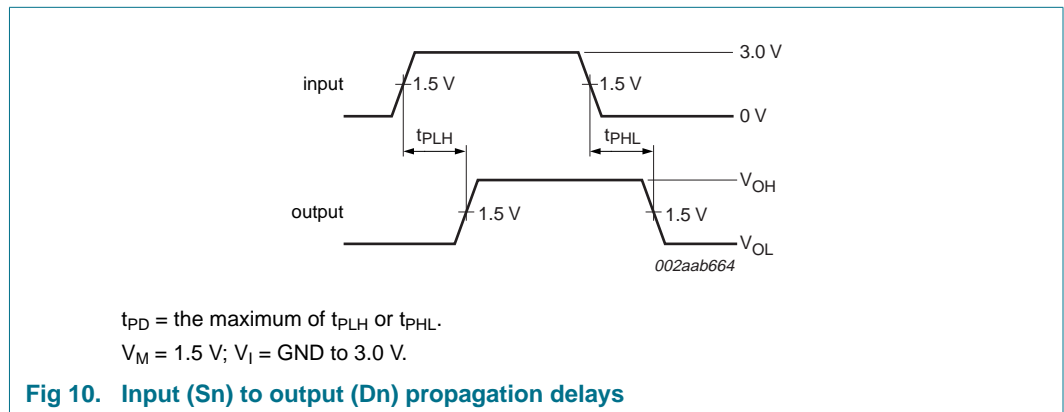

13. Test information

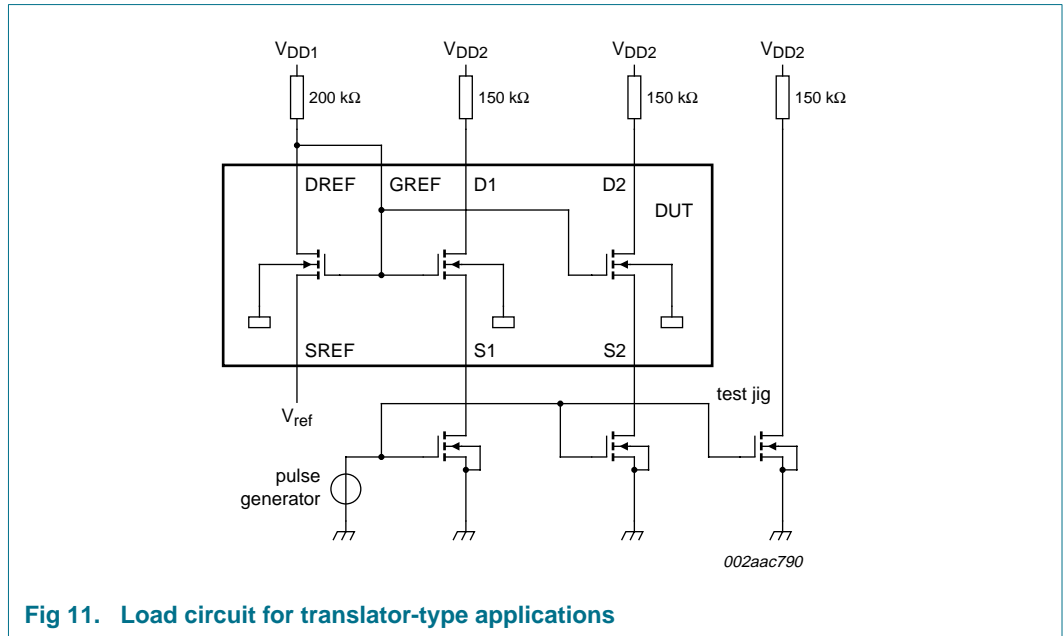

Fig 11. Load circuit for translator-type applications

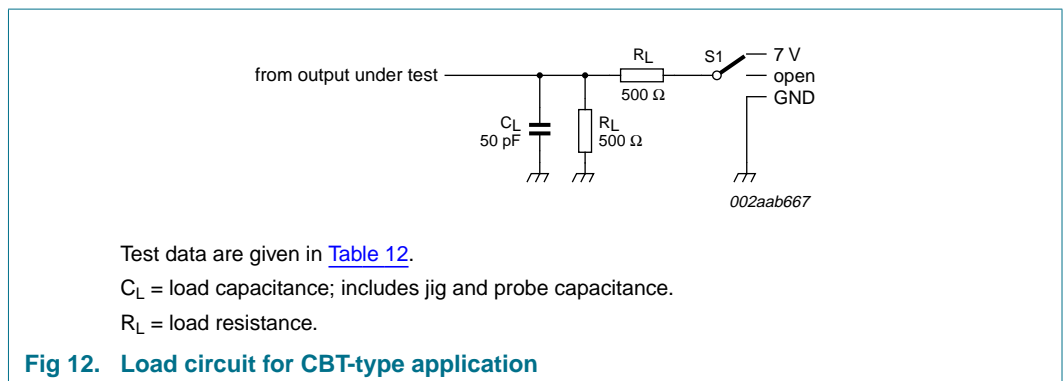

Fig 12. Load circuit for CBT-type application

Table 12. Test data

Test	Load		Switch
	C_L	R_L	
t_{PD}	50 pF	500 Ω	open

14. Package outline

SO8: plastic small outline package; 8 leads; body width 3.9 mm

SOT96-1

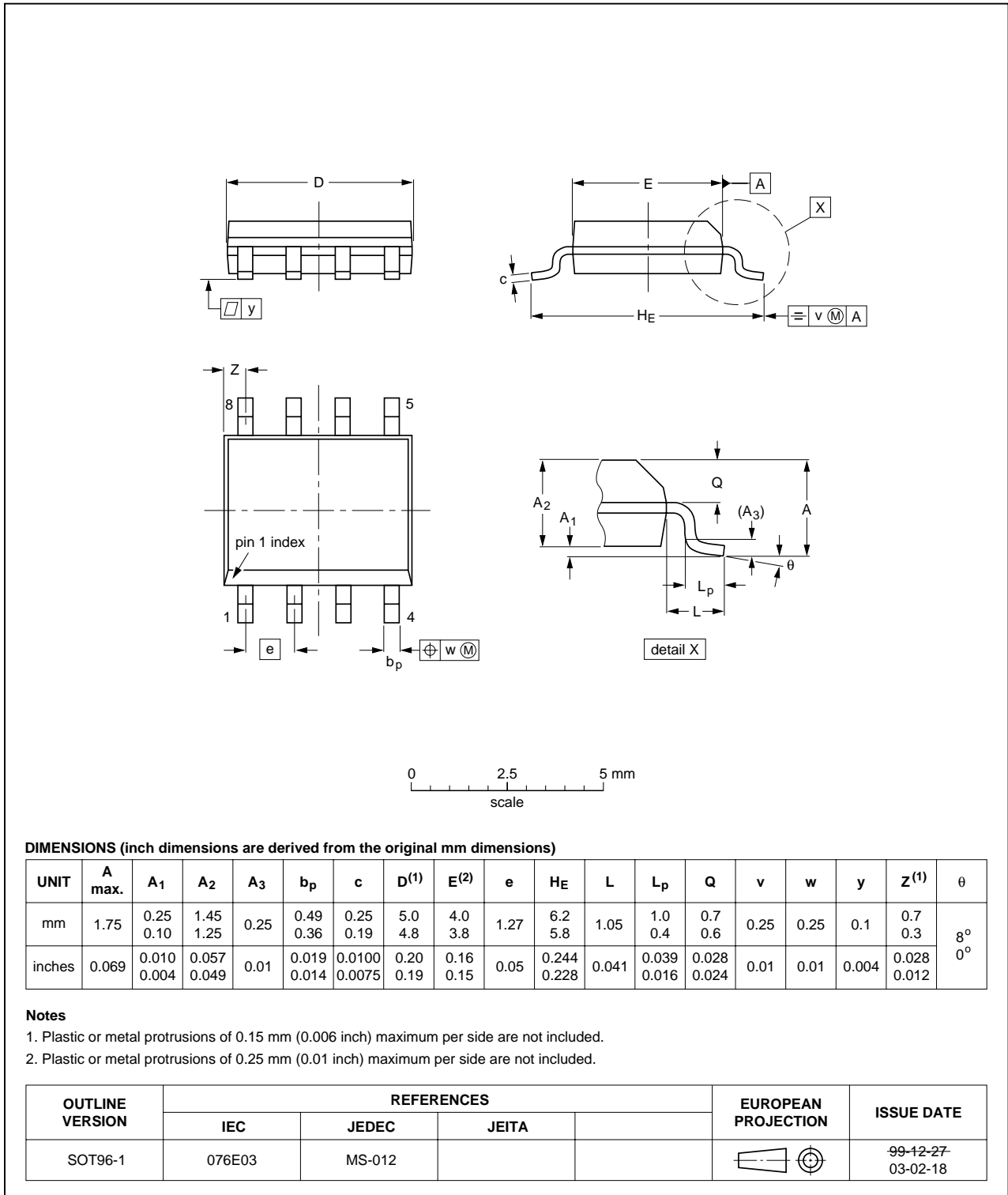

Fig 13. Package outline SOT96-1 (SO8)

TSSOP8: plastic thin shrink small outline package; 8 leads; body width 3 mm

SOT505-1

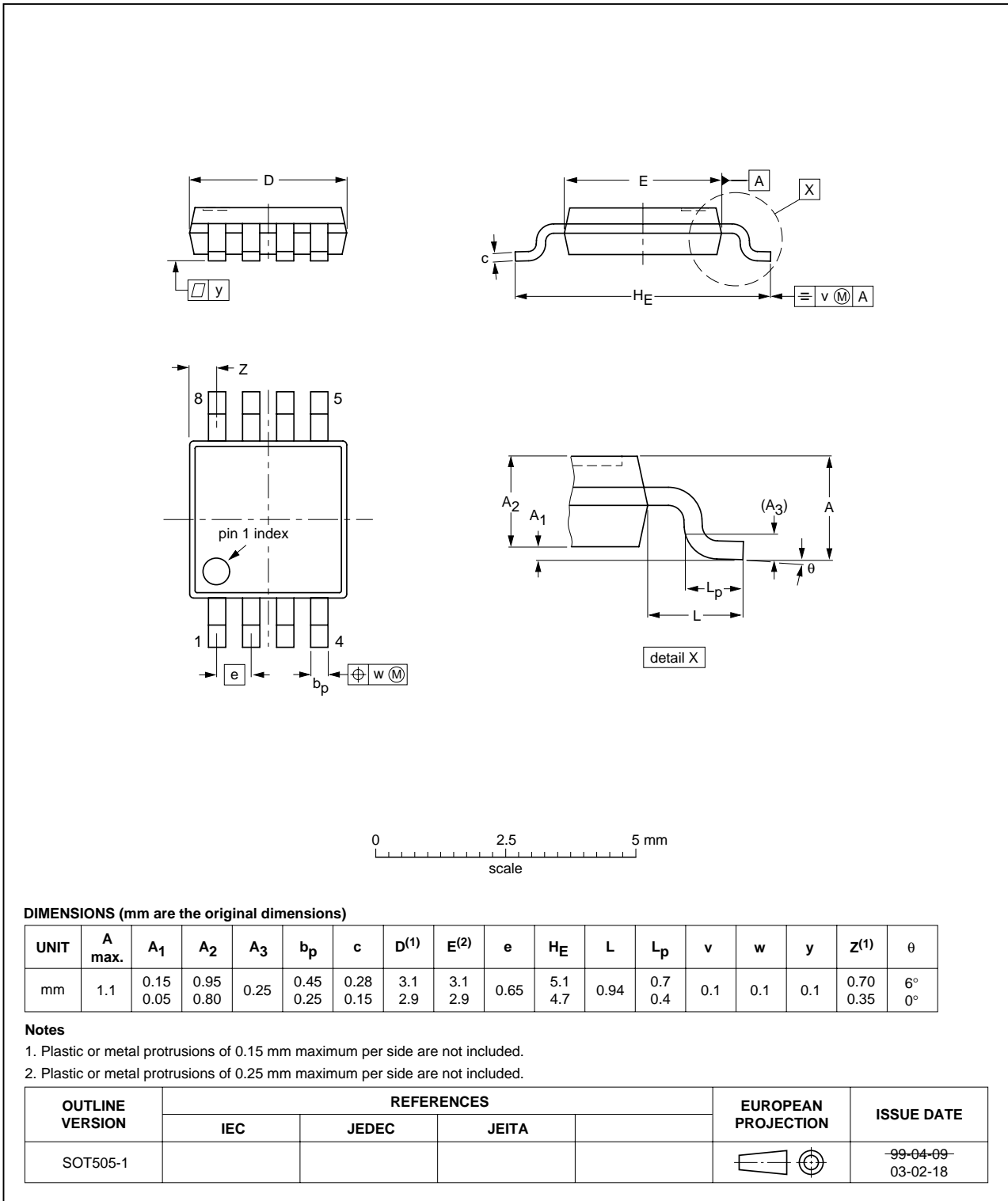

Fig 14. Package outline SOT505-1 (TSSOP8)

VSSOP8: plastic very thin shrink small outline package; 8 leads; body width 2.3 mm

SOT765-1

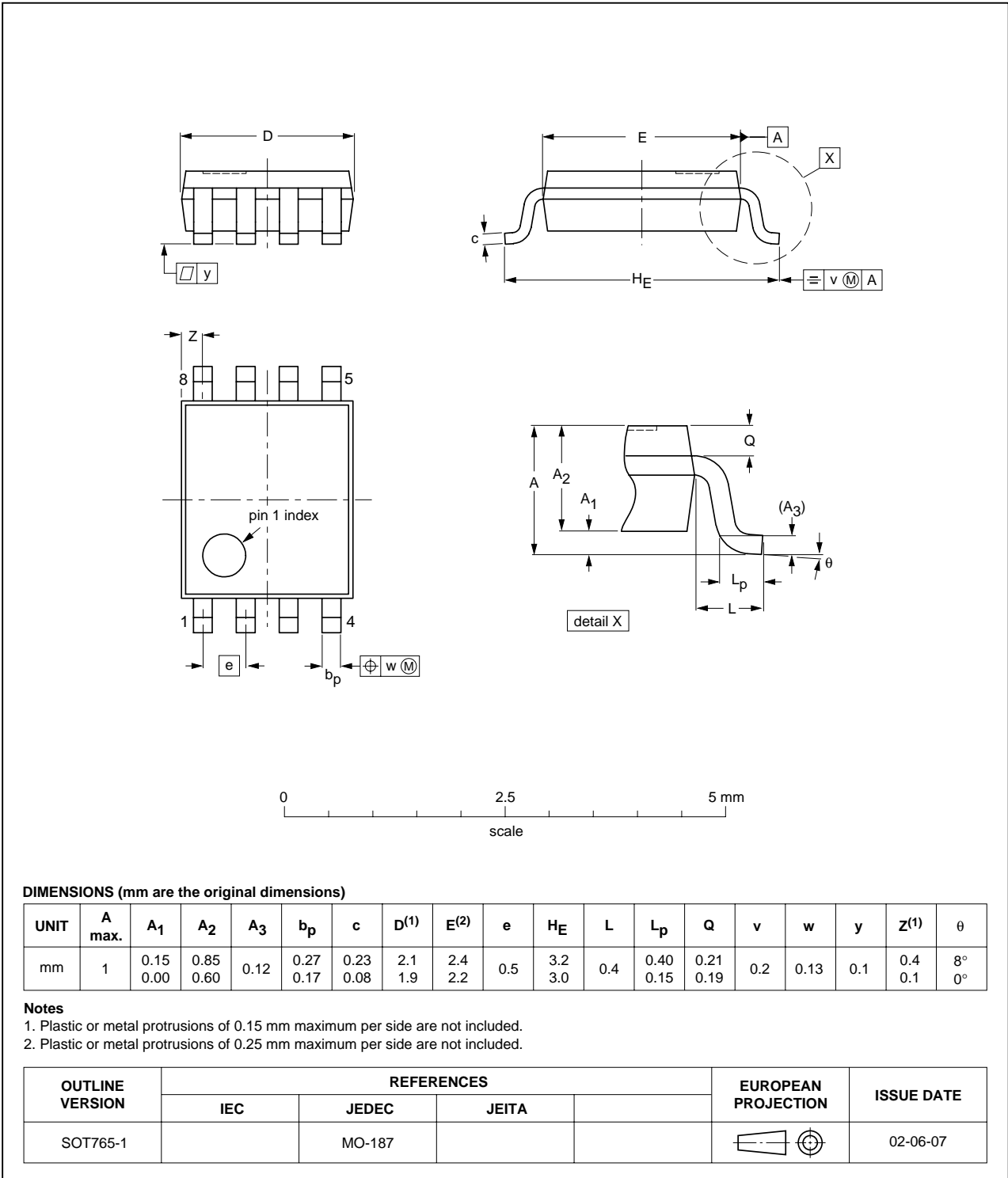

Fig 15. Package outline SOT765-1 (VSSOP8)

XQFN8U: plastic extremely thin quad flat package; no leads; 8 terminals; UTLP based; body 1.6 x 1.6 x 0.5 mm

SOT902-1

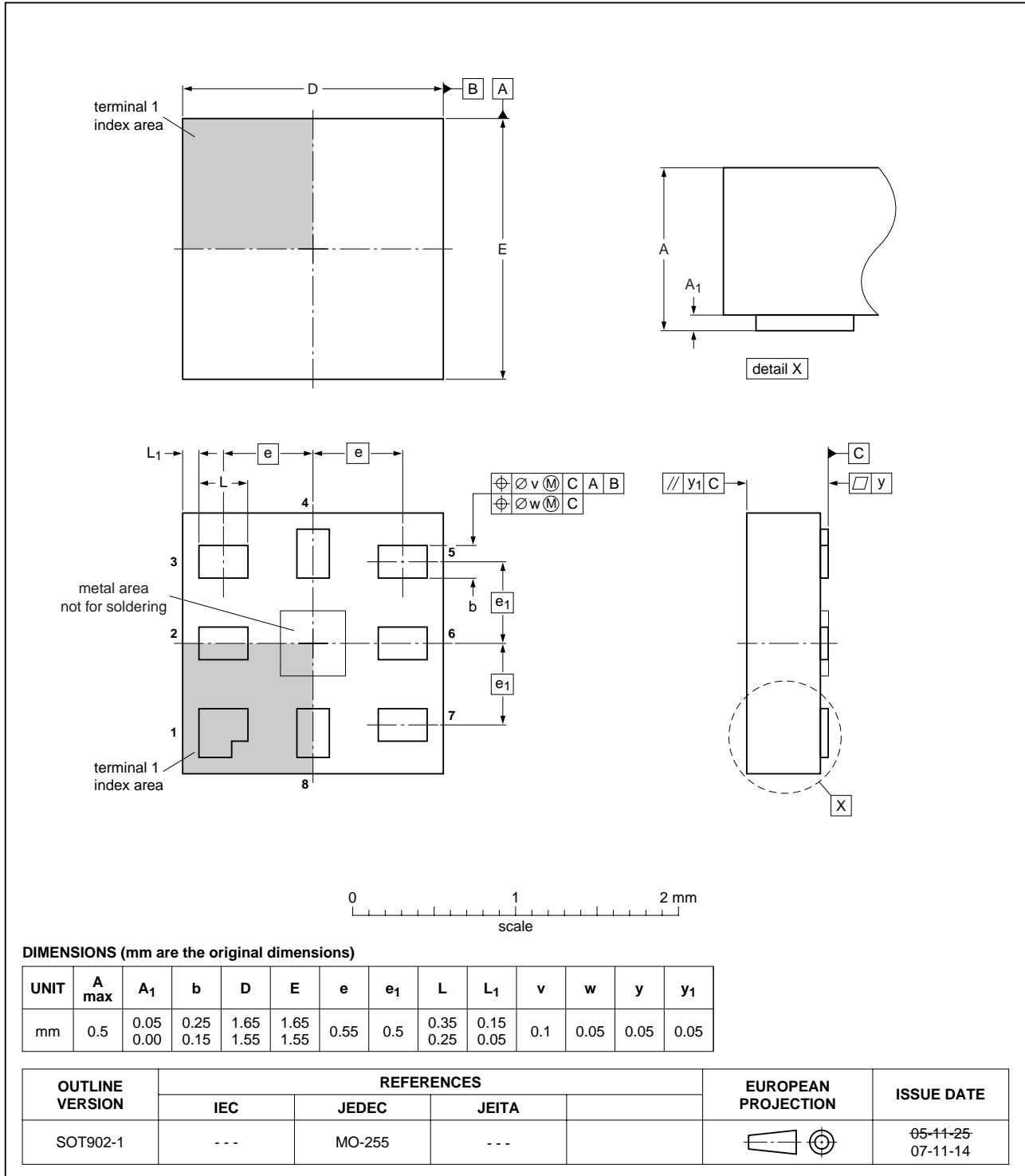

Fig 16. Package outline SOT902-1 (XQFN8U)

15. Soldering of SMD packages

This text provides a very brief insight into a complex technology. A more in-depth account of soldering ICs can be found in Application Note *AN10365 "Surface mount reflow soldering description"*.

15.1 Introduction to soldering

Soldering is one of the most common methods through which packages are attached to Printed Circuit Boards (PCBs), to form electrical circuits. The soldered joint provides both the mechanical and the electrical connection. There is no single soldering method that is ideal for all IC packages. Wave soldering is often preferred when through-hole and Surface Mount Devices (SMDs) are mixed on one printed wiring board; however, it is not suitable for fine pitch SMDs. Reflow soldering is ideal for the small pitches and high densities that come with increased miniaturization.

15.2 Wave and reflow soldering

Wave soldering is a joining technology in which the joints are made by solder coming from a standing wave of liquid solder. The wave soldering process is suitable for the following:

- Through-hole components
- Leaded or leadless SMDs, which are glued to the surface of the printed circuit board

Not all SMDs can be wave soldered. Packages with solder balls, and some leadless packages which have solder lands underneath the body, cannot be wave soldered. Also, leaded SMDs with leads having a pitch smaller than ~0.6 mm cannot be wave soldered, due to an increased probability of bridging.

The reflow soldering process involves applying solder paste to a board, followed by component placement and exposure to a temperature profile. Leaded packages, packages with solder balls, and leadless packages are all reflow solderable.

Key characteristics in both wave and reflow soldering are:

- Board specifications, including the board finish, solder masks and vias
- Package footprints, including solder thieves and orientation
- The moisture sensitivity level of the packages
- Package placement
- Inspection and repair
- Lead-free soldering versus SnPb soldering

15.3 Wave soldering

Key characteristics in wave soldering are:

- Process issues, such as application of adhesive and flux, clinching of leads, board transport, the solder wave parameters, and the time during which components are exposed to the wave
- Solder bath specifications, including temperature and impurities

15.4 Reflow soldering

Key characteristics in reflow soldering are:

- Lead-free versus SnPb soldering; note that a lead-free reflow process usually leads to higher minimum peak temperatures (see [Figure 17](#)) than a SnPb process, thus reducing the process window
- Solder paste printing issues including smearing, release, and adjusting the process window for a mix of large and small components on one board
- Reflow temperature profile; this profile includes preheat, reflow (in which the board is heated to the peak temperature) and cooling down. It is imperative that the peak temperature is high enough for the solder to make reliable solder joints (a solder paste characteristic). In addition, the peak temperature must be low enough that the packages and/or boards are not damaged. The peak temperature of the package depends on package thickness and volume and is classified in accordance with [Table 13](#) and [14](#)

Table 13. SnPb eutectic process (from J-STD-020C)

Package thickness (mm)	Package reflow temperature (°C)	
	Volume (mm ³)	
	< 350	≥ 350
< 2.5	235	220
≥ 2.5	220	220

Table 14. Lead-free process (from J-STD-020C)

Package thickness (mm)	Package reflow temperature (°C)		
	Volume (mm ³)		
	< 350	350 to 2000	> 2000
< 1.6	260	260	260
1.6 to 2.5	260	250	245
> 2.5	250	245	245

Moisture sensitivity precautions, as indicated on the packing, must be respected at all times.

Studies have shown that small packages reach higher temperatures during reflow soldering, see [Figure 17](#).

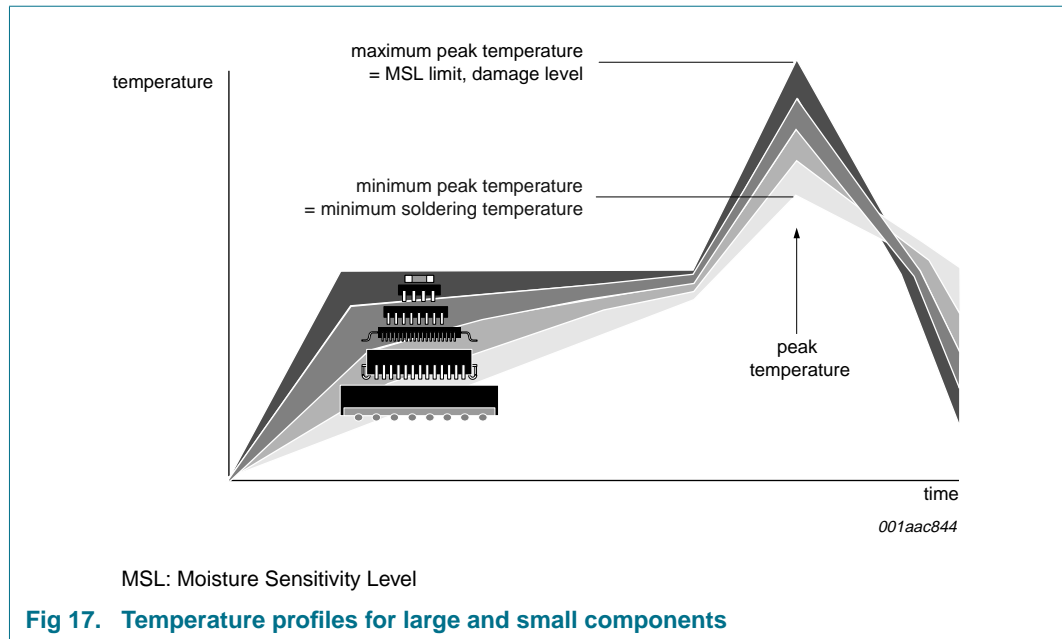

For further information on temperature profiles, refer to Application Note AN10365 “Surface mount reflow soldering description”.

16. Abbreviations

Table 15. Abbreviations

Acronym	Description
CBT	Cross Bar Technology
CDM	Charged-Device Model
CMOS	Complementary Metal-Oxide Semiconductor
CPU	Central Processing Unit
ESD	ElectroStatic Discharge
GTL	Gunning Transceiver Logic
HBM	Human Body Model
I/O	Input/Output
I ² C-bus	Inter-Integrated Circuit bus
LVTTTL	Low Voltage Transistor-Transistor Logic
MM	Machine Model
NMOS	Negative-channel Metal-Oxide Semiconductor
RC	Resistor Capacitor network
TTL	Transistor-Transistor Logic
TVC	Transceiver Voltage Clamps

17. Revision history

Table 16. Revision history

Document ID	Release date	Data sheet status	Change notice	Supersedes
GTL2002_7	20090702	Product data sheet	-	GTL2002_6
Modifications:	<ul style="list-style-type: none"> • Table 1 “Ordering information”: added type number GTL2002DP/Q900 • Table 2 “Ordering options”: added type number GTL2002DP/Q900 • Figure 3 “Pin configuration for TSSOP8 (MSOP8)”: added type number GTL2002DP/Q900 • Table 8 “Recommended operating conditions”: deleted (empty) Typ column • updated soldering information 			
GTL2002_6	20071221	Product data sheet	-	GTL2002_5
GTL2002_5	20070813	Product data sheet	-	GTL2002_4
GTL2002_4	20060829	Product data sheet	-	GTL2002_3
GTL2002_3 (9397 750 13058)	20040929	Product data sheet	-	GTL2002_2
GTL2002_2 (9397 750 11349)	20030401	Product data	ECN 853-2214 29603 dated 2003 Feb 28	GTL2002_1
GTL2002_1 (9397 750 07417)	20000216	Product specification	ECN 853-2214 24367 dated 2000 Aug 16	-

18. Legal information

18.1 Data sheet status

Document status ^{[1][2]}	Product status ^[3]	Definition
Objective [short] data sheet	Development	This document contains data from the objective specification for product development.
Preliminary [short] data sheet	Qualification	This document contains data from the preliminary specification.
Product [short] data sheet	Production	This document contains the product specification.

[1] Please consult the most recently issued document before initiating or completing a design.

[2] The term 'short data sheet' is explained in section "Definitions".

[3] The product status of device(s) described in this document may have changed since this document was published and may differ in case of multiple devices. The latest product status information is available on the Internet at URL <http://www.nxp.com>.

18.2 Definitions

Draft — The document is a draft version only. The content is still under internal review and subject to formal approval, which may result in modifications or additions. NXP Semiconductors does not give any representations or warranties as to the accuracy or completeness of information included herein and shall have no liability for the consequences of use of such information.

Short data sheet — A short data sheet is an extract from a full data sheet with the same product type number(s) and title. A short data sheet is intended for quick reference only and should not be relied upon to contain detailed and full information. For detailed and full information see the relevant full data sheet, which is available on request via the local NXP Semiconductors sales office. In case of any inconsistency or conflict with the short data sheet, the full data sheet shall prevail.

18.3 Disclaimers

General — Information in this document is believed to be accurate and reliable. However, NXP Semiconductors does not give any representations or warranties, expressed or implied, as to the accuracy or completeness of such information and shall have no liability for the consequences of use of such information.

Right to make changes — NXP Semiconductors reserves the right to make changes to information published in this document, including without limitation specifications and product descriptions, at any time and without notice. This document supersedes and replaces all information supplied prior to the publication hereof.

Suitability for use — NXP Semiconductors products are not designed, authorized or warranted to be suitable for use in medical, military, aircraft, space or life support equipment, nor in applications where failure or malfunction of an NXP Semiconductors product can reasonably be expected to result in personal injury, death or severe property or environmental

damage. NXP Semiconductors accepts no liability for inclusion and/or use of NXP Semiconductors products in such equipment or applications and therefore such inclusion and/or use is at the customer's own risk.

Applications — Applications that are described herein for any of these products are for illustrative purposes only. NXP Semiconductors makes no representation or warranty that such applications will be suitable for the specified use without further testing or modification.

Limiting values — Stress above one or more limiting values (as defined in the Absolute Maximum Ratings System of IEC 60134) may cause permanent damage to the device. Limiting values are stress ratings only and operation of the device at these or any other conditions above those given in the Characteristics sections of this document is not implied. Exposure to limiting values for extended periods may affect device reliability.

Terms and conditions of sale — NXP Semiconductors products are sold subject to the general terms and conditions of commercial sale, as published at <http://www.nxp.com/profile/terms>, including those pertaining to warranty, intellectual property rights infringement and limitation of liability, unless explicitly otherwise agreed to in writing by NXP Semiconductors. In case of any inconsistency or conflict between information in this document and such terms and conditions, the latter will prevail.

No offer to sell or license — Nothing in this document may be interpreted or construed as an offer to sell products that is open for acceptance or the grant, conveyance or implication of any license under any copyrights, patents or other industrial or intellectual property rights.

Export control — This document as well as the item(s) described herein may be subject to export control regulations. Export might require a prior authorization from national authorities.

18.4 Trademarks

Notice: All referenced brands, product names, service names and trademarks are the property of their respective owners.

19. Contact information

For more information, please visit: <http://www.nxp.com>

For sales office addresses, please send an email to: salesaddresses@nxp.com

20. Contents

1	General description	1
2	Features	1
3	Applications	2
4	Ordering information	2
4.1	Ordering options	2
5	Functional diagram	3
6	Pinning information	3
6.1	Pinning	3
6.2	Pin description	4
7	Functional description	4
7.1	Function selection	4
8	Application design-in information	5
8.1	Bidirectional translation	5
8.2	Unidirectional down translation	6
8.3	Unidirectional up translation	6
8.4	Sizing pull-up resistor	7
9	Limiting values	8
10	Recommended operating conditions	8
11	Static characteristics	9
12	Dynamic characteristics	10
12.1	Dynamic characteristics for translator-type application	10
12.2	Dynamic characteristics for CBT-type application	11
13	Test information	12
14	Package outline	13
15	Soldering of SMD packages	17
15.1	Introduction to soldering	17
15.2	Wave and reflow soldering	17
15.3	Wave soldering	17
15.4	Reflow soldering	18
16	Abbreviations	19
17	Revision history	20
18	Legal information	21
18.1	Data sheet status	21
18.2	Definitions	21
18.3	Disclaimers	21
18.4	Trademarks	21
19	Contact information	21
20	Contents	22

Please be aware that important notices concerning this document and the product(s) described herein, have been included in section 'Legal information'.



© NXP B.V. 2009.

All rights reserved.

For more information, please visit: <http://www.nxp.com>

For sales office addresses, please send an email to: salesaddresses@nxp.com

Date of release: 2 July 2009

Document identifier: GTL2002_7