



SE95

Ultra high accuracy digital temperature sensor and thermal watchdog

Rev. 07 — 2 September 2009

Product data sheet

1. General description

The SE95 is a temperature-to-digital converter using an on-chip band gap temperature sensor and Sigma Delta analog-to-digital conversion technique. The device is also a thermal detector providing an overtemperature detection output.

The SE95 contains a number of data registers accessed by a controller via the 2-wire serial I²C-bus interface:

- Configuration register (Conf) to store the device settings such as sampling rate, device operation mode, OS operation mode, OS polarity, and OS fault queue
- Temperature register (Temp) to store the digital Temp reading
- Set-point registers (Tos and Thyst) to store programmable overtemperature shutdown and hysteresis limits
- Identification register (ID) to store manufacturer numbers

The device includes an open-drain output (pin OS) which becomes active when the temperature exceeds the programmed limits. There are three selectable logic address pins (pins A2 to A0) so that eight devices can be connected on the same bus without address conflict.

The SE95 can be configured for different operation conditions. It can be set in normal mode to periodically monitor the ambient temperature, or in shutdown mode to minimize power consumption. The OS output operates in either of two selectable modes: OS comparator mode and OS interrupt mode. Its active state can be selected as either HIGH or LOW. The fault queue that defines the number of consecutive faults in order to activate the OS output is programmable as well as the set-point limits.

The temperature register always stores a 13-bit two's complement data giving a temperature resolution of 0.03125 °C. This high temperature resolution is particularly useful in applications of measuring precisely the thermal drift or runaway. For normal operation and compatibility with the LM75A, only the 11 MSBs are read, with a resolution of 0.125 °C to provide the accuracies specified. To be compatible with the LM75, read only the 9 MSBs.

The device is powered-up in normal operation mode with the OS in comparator mode, temperature threshold of 80 °C and hysteresis of 75 °C, so that it can be used as a stand-alone thermostat with those pre-defined temperature set points. The conversion rate is programmable, with a default of 10 conversions/s.

2. Features

- Pin-for-pin replacement for industry standard LM75/LM75A
- Specification of a single part over supply voltage from 2.8 V to 5.5 V
- Small 8-pin package types: SO8 and TSSOP8 (MSOP8)
- I²C-bus interface to 400 kHz with up to 8 devices on the same bus
- Supply voltage from 2.8 V to 5.5 V
- Temperature range from -55 °C to +125 °C
- 13-bit ADC that offers a temperature resolution of 0.03125 °C
- Temperature accuracy of ± 1 °C from -25 °C to +100 °C
- Programmable temperature threshold and hysteresis set points
- Supply current of 7.0 µA in shutdown mode for power conservation
- Stand-alone operation as thermostat at power-up
- ESD protection exceeds 1000 V for Human Body Model (HBM) per JESD22-A114 and 150 V for Machine Model (MM) per JESD22-A115
- Latch-up testing is done to JEDEC Standard JESD78 which exceeds 100 mA

3. Applications

- System thermal management
- Personal computers
- Electronics equipment
- Industrial controllers

4. Ordering information

Table 1. Ordering information

Type number	Package			
	Temperature range	Name	Description	Version
SE95D	-55 °C to +125 °C	SO8	plastic small outline package; 8 leads; body width 3.9 mm	SOT96-1
SE95DP	-55 °C to +125 °C	TSSOP8	plastic thin shrink small outline package; 8 leads; body width 3 mm	SOT505-1
SE95U	-55 °C to +125 °C	-	wafer	-

5. Block diagram

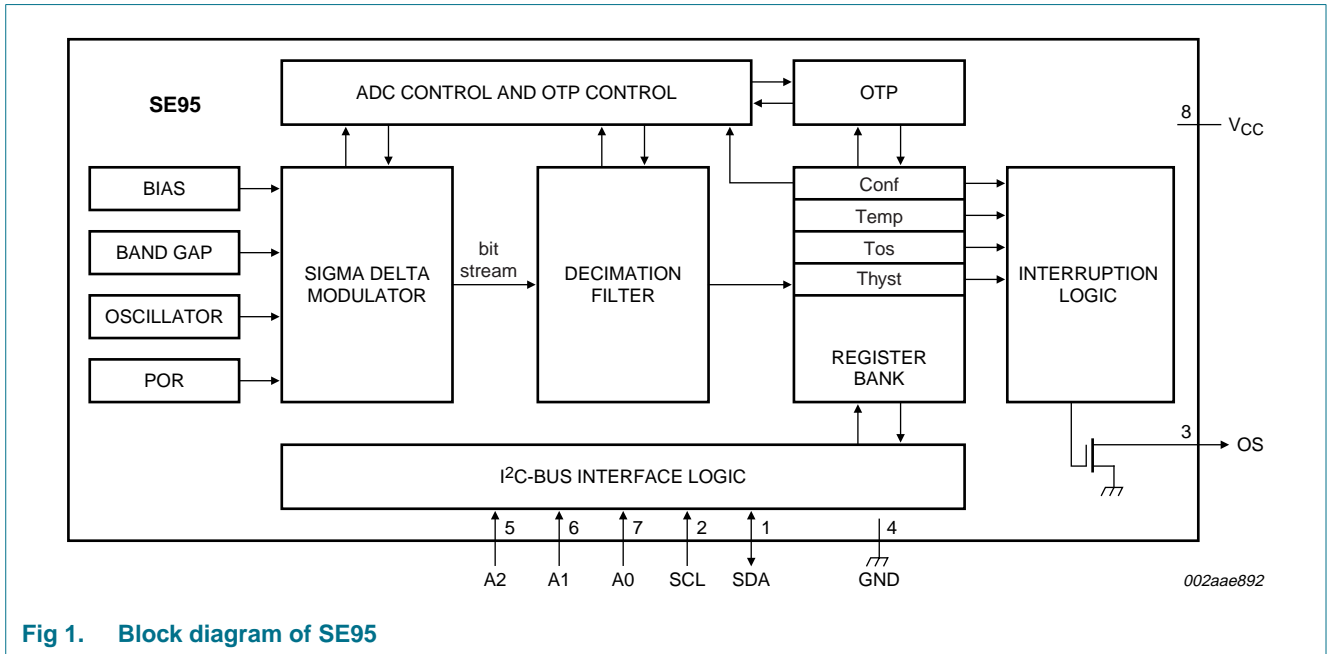

Fig 1. Block diagram of SE95

6. Pinning information

6.1 Pinning

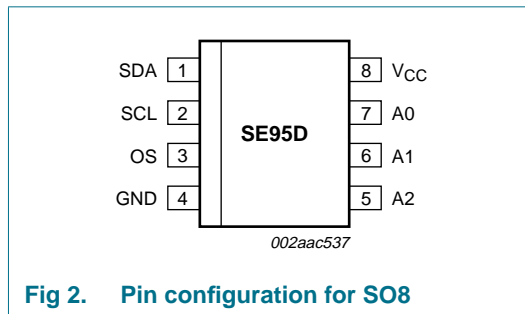

Fig 2. Pin configuration for SO8

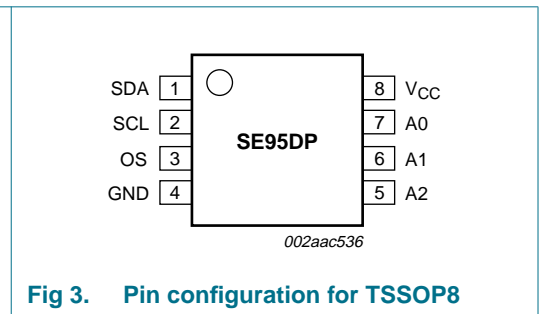

Fig 3. Pin configuration for TSSOP8

6.2 Pin description

Table 2. Pin description

Symbol	Pin	Description
SDA	1	I ² C-bus serial bidirectional data line digital I/O; open-drain
SCL	2	I ² C-bus serial clock digital input
OS	3	overtemperature shutdown output; open-drain
GND	4	ground; to be connected to the system ground
A2	5	user-defined address bit 2 digital input

Table 2. Pin description ...continued

Symbol	Pin	Description
A1	6	user-defined address bit 1 digital input
A0	7	user-defined address bit 0 digital input
V _{CC}	8	supply voltage

7. Functional description

7.1 General operation

The SE95 uses the on-chip band gap sensor to measure the device temperature with a resolution of 0.03125 °C and stores the 13-bit two's complement digital data, resulting from 13-bit analog to digital conversion, into register Temp. Register Temp can be read at any time by a controller on the I²C-bus. Reading temperature data does not affect the conversion in progress during the read operation.

The device can be set to operate in either mode: normal or shutdown mode. In normal operation mode, by default, the temperature-to-digital conversion is executed every 100 ms and register Temp is updated at the end of each conversion. In shutdown mode, the device becomes idle, data conversion is disabled and register Temp holds the latest result; however, the device I²C-bus interface is still active and register write/read operation can be performed. The device operation mode is controlled by programming bit SHUTDOWN of register Conf. The temperature conversion is initiated when the device is powered up or returned to normal mode from shutdown mode.

In addition, at the end of each conversion in normal mode, the temperature data (or Temp) in register Temp is automatically compared with the overtemperature shutdown threshold data (or Tos) stored in register Tos, and the hysteresis data (or Thyst) stored in register Thyst, in order to set the state of the device OS output accordingly. The registers Tos and Thyst are write/read capable, and both operate with 9-bit two's complement digital data. To match with this 9-bit operation, register Temp uses only the 9 MSB bits of its 13-bit data for the comparison.

The device temperature conversion rate is programmable and can be chosen to be one of the four values: 0.125, 1.0, 10, and 30 conversions/s. The default conversion rate is 10 conversions/s. Furthermore, the conversion rate is selected by programming bits RATEVAL[1:0] of register Conf as shown in [Table 6](#). Note that the average supply current as well as the device power consumption increase with the conversion rate.

The way that the OS output responds to the comparison operation depends upon the OS operation mode selected by configuration bit OS_COMP_INT, and the user-defined fault queue defined by configuration bits OS_F_QUE[1:0].

In OS comparator mode, the OS output behaves like a thermostat. It becomes active when the temperature exceeds T_{OS}, and is reset when the temperature drops below T_{hyst}. Reading the device registers or putting the device into shutdown mode does not change the state of the OS output. The OS output in this case can be used to control cooling fans or thermal switches.

In OS interrupt mode, the OS output is used for thermal interruption. When the device is powered-up, the OS output is first activated only when Temp exceeds T_{OS} ; then it remains active indefinitely until being reset by a read of any register. Once the OS output has been activated by crossing T_{OS} and then reset, it can be activated again only when Temp drops below T_{hyst} ; then again, it remains active indefinitely until being reset by a read of any register. The OS interrupt operation would be continued in this sequence: T_{OS} trip, reset, T_{hyst} trip, reset, T_{OS} trip, reset, T_{hyst} trip, reset, and etc. Putting the device into shutdown mode also resets the OS output.

In both cases, comparator mode and interrupt mode, the OS output is activated only if a number of consecutive faults, defined by the device fault queue, has been met. The fault queue is programmable and stored in bits OS_F_QUE[1:0], of register Conf. Also, the OS output active state is selectable as HIGH or LOW by setting accordingly the bit OS_POL of register Conf.

At power-up, the device is put into normal operation mode, register Tos is set to 80 °C, register Thyst is set to 75 °C, OS active state is selected LOW and the fault queue is equal to 1. The data reading of register Temp is not available until the first conversion is completed in about 33 ms.

The OS response to the temperature is illustrated in [Figure 4](#).

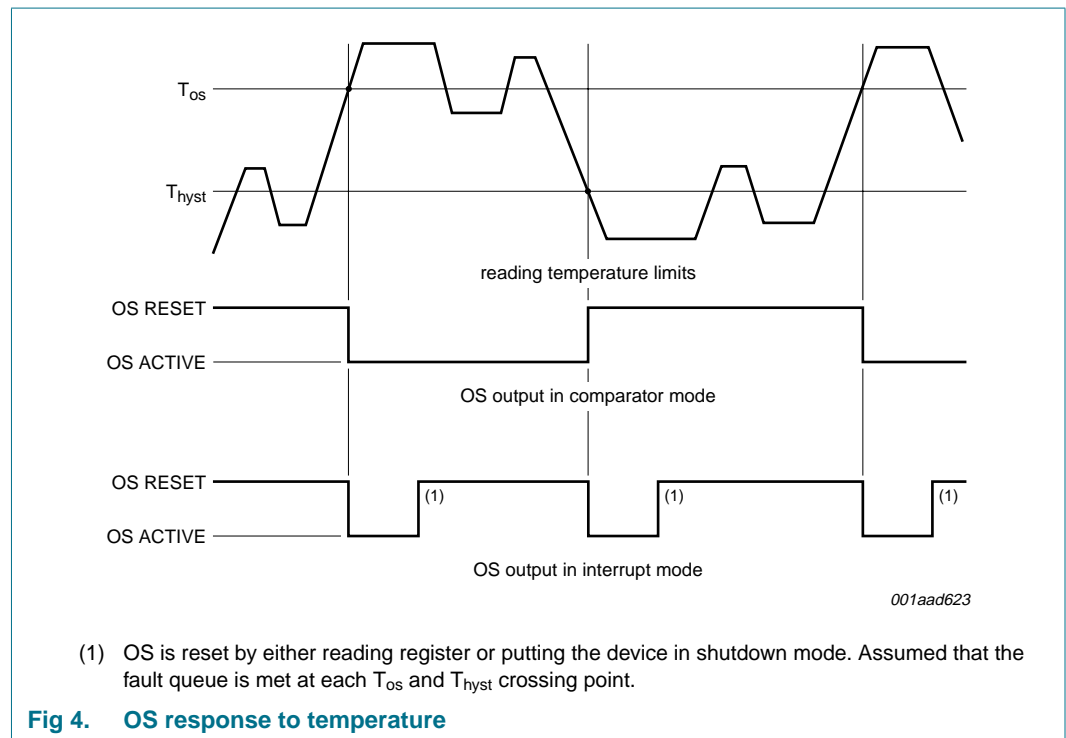

7.2 OS output and polarity

The OS output is an open-drain output and its state represents results of the device watchdog operation as described in [Section 7.1](#). In order to observe this output state, an external pull-up resistor is needed. The resistor should be as large as possible, up to 200 k Ω , to minimize the Temp reading error due to internal heating by the high OS sinking current.

The OS output active state can be selected as HIGH or LOW by programming bit OS_POL of register Conf: setting bit OS_POL to logic 1 selects OS active HIGH and setting to logic 0 sets OS active LOW. At power-up, bit OS_POL is equal to logic 0 and the OS active state is LOW.

7.3 OS comparator and interrupt modes

As described in [Section 7.1](#), the OS output responds to the result of the comparison between register Temp data and the programmed limits, in registers Tos and Thyst, in different ways depending on the selected OS mode: OS comparator or OS interrupt. The OS mode is selected by programming bit OS_COMP_INT of register Conf: setting bit OS_COMP_INT to logic 1 selects the OS interrupt mode, and setting to logic 0 selects the OS comparator mode. At power-up, bit OS_COMP_INT is equal to logic 0 and the OS comparator is selected.

The main difference between the two modes is that in OS comparator mode, the OS output becomes active when Temp has exceeded T_{os} and reset when Temp has dropped below T_{hyst} , reading a register or putting the device into shutdown mode does not change the state of the OS output; while in OS interrupt mode, once it has been activated either by exceeding T_{os} or dropping below T_{hyst} , the OS output will remain active indefinitely until reading a register or putting the device into shutdown mode occurs, then the OS output is reset.

Temperature limits T_{os} and T_{hyst} must be selected so that $T_{os} > T_{hyst}$. Otherwise, the OS output state will be undefined.

7.4 OS fault queue

Fault queue is defined as the number of faults that must occur consecutively to activate the OS output. It is provided to avoid false tripping due to noise. Because faults are determined at the end of data conversions, fault queue is also defined as the number of consecutive conversions returning a temperature trip. The value of fault queue is selectable by programming the two bits OS_F_QUE[1:0] in register Conf. Notice that the programmed data and the fault queue value are not the same. [Table 3](#) shows the one-to-one relationship between them. At power-up, fault queue data = 00 and fault queue value = 1.

Table 3. Fault queue table

Fault queue data		Fault queue value
OS_F_QUE[1]	OS_F_QUE[0]	Decimal
0	0	1
0	1	2
1	0	4
1	1	6

7.5 Shutdown mode

The device operation mode is selected by programming bit SHUTDOWN of register Conf. Setting bit SHUTDOWN to logic 1 will put the device into shutdown mode. Resetting bit SHUTDOWN to logic 0 will return the device to normal mode.

In shutdown mode, the device draws a small current of approximately 7.5 μA and the power dissipation is minimized; the temperature conversion stops, but the I²C-bus interface remains active and register write/read operation can be performed. If the OS output is in comparator mode, then it remains unchanged. In interrupt mode, the OS output is reset.

7.6 Power-up default and power-on reset

The SE95 always powers-up in its default state with:

- Normal operation mode
- OS comparator mode
- $T_{\text{os}} = 80\text{ }^{\circ}\text{C}$
- $T_{\text{hyst}} = 75\text{ }^{\circ}\text{C}$
- OS output active state is LOW
- Pointer value is logic 0

When the power supply voltage is dropped below the device power-on reset level of approximately 1.9 V (POR) and then rises up again, the device will be reset to its default condition as listed above.

8. I²C-bus serial interface

The SE95 can be connected to a compatible 2-wire serial interface I²C-bus as a slave device under the control of a controller or master device, using two device terminals, SCL and SDA. The controller must provide the SCL clock signal and write/read data to and from the device through the SDA terminal. Note that if the I²C-bus common pull-up resistors have not been installed as required for I²C-bus, then an external pull-up resistor, approximately 10 k Ω , is needed for each of these two terminals. The bus communication protocols are described in [Section 8.7 "Protocols for writing and reading the registers"](#).

8.1 Slave address

The SE95 slave address on the I²C-bus is partially defined by the logic applied to the device address pins A2, A1 and A0. Each pin is typically connected either to GND for logic 0, or to V_{CC} for logic 1. These pins represent the three LSB bits of the device 7-bit address. The other four MSB bits of the address data are preset to 1001 by hard wiring inside the SE95. [Table 4](#) shows the device's complete address and indicates that up to 8 devices can be connected to the same bus without address conflict. Because the input pins SCL, SDA and A2 to A0, are not internally biased, it is important that they should not be left floating in any application.

0Ch is a reserved address for SMBus Alert Response Address (ARA). This is an optional command from the SMBus specification to allow SMBus devices to respond to an SMBus master with their slave device if they are generating an interrupt. The SE95 will send a

false alert if the address 0Ch is sent and cannot be active on the I²C-bus if this address is used. Consider using the SE98 since it supports SMBus ARA as well as time-out features and provides ± 1 °C accuracy.

Table 4. Address table

MSB				LSB		
1	0	0	1	A2	A1	A0

8.2 Register list

The SE95 contains 7 data registers. The registers can be 1 byte or 2 bytes wide, and are defined in [Table 5](#). The registers are accessed by the value in the content of the pointer register during I²C-bus communication. The types of registers are: read only, read/write, and reserved for manufacturer use. Note that when reading a two-byte register, the host must provide enough clock pulses as required by the I²C-bus protocol (see [Section 8.7](#)) for the device to completely return both data bytes. Otherwise the device may hold the SDA line in LOW state, resulting in a bus hang condition.

Table 5. Register table

Register name	Pointer value	R/W	POR state	Description
Conf	01h	R/W	00h	configuration register: contains a single 8-bit data byte; to set an operating condition
Temp	00h	read only	N/A	temperature register: contains two 8-bit data bytes; to store the measured Temp
Tos	03h	R/W	5000h	overtemperature shutdown threshold register: contains two 8-bit data bytes; to store the overtemperature shutdown limit; default T _{os} = 80 °C
Thyst	02h	R/W	4B00h	hysteresis register: contains two 8-bit data bytes; to store the hysteresis limit; bit 7 to bit 0 are also used in OTP (One Time Programmable) test mode to supply OTP write data; default T _{hyst} = 75 °C
ID	05h	read only	A1h	identification register: contains a single 8-bit data byte for the manufacturer ID code
Reserved	04h	N/A	N/A	reserved
Reserved	06h	N/A	N/A	reserved

8.3 Register pointer

The register pointer or pointer byte is an 8-bit data byte that is equivalent to the register command in the I²C-bus definitions and is used to identify the device register to be accessed for a write or read operation. Its values are listed as pointer values in [Table 5](#). For the device register I²C-bus communication, the pointer byte may or may not need to be included within the command as illustrated in the I²C-bus protocol figures in [Section 8.7](#).

The command statements for writing data to a register must always include the pointer byte; while the command statements for reading data from a register may or may not include it. To read a register that is different from the one that has been recently read, the pointer byte must be included. However, to re-read a register that has been recently read, the pointer byte may not have to be included in the reading.

At power-up, the pointer value is preset to logic 0 for register Temp; users can then read the temperature without specifying the pointer byte.

8.4 Configuration register

The Configuration (Conf) register is a read/write register and contains an 8-bit non-complement data byte that is used to configure the device for different operating conditions. [Table 6](#) shows the bit assignments of this register.

Table 6. Conf register

Legend: * = default value.

Bit	Symbol	Access	Value	Description
7	reserved	R/W	0*	reserved for manufacturer's use
6 and 5	RATEVAL[1:0]	R/W		sets the conversion rate
			00*	10 conversion/s
			01	0.125 conversion/s
			10	1 conversion/s
			11	30 conversion/s
4 and 3	OS_F_QUE[1:0]	R/W		OS fault queue programming
			00*	queue value = 1
			01	queue value = 2
			10	queue value = 4
			11	queue value = 6
2	OS_POL	R/W		OS polarity selection
			0*	OS active LOW
			1	OS active HIGH
1	OS_COMP_INT	R/W		OS operation mode selection
			0*	OS comparator
			1	OS interrupt
0	SHUTDOWN	R/W	0	operation mode
			0*	normal
			1	shutdown

8.5 Temperature register

The Temperature (Temp) register holds the digital result of temperature measurement or monitor at the end of each analog to digital conversion. This register is read only and contains two 8-bit data bytes consisting of one Most Significant Byte (MSByte) and one Least Significant Byte (LSByte). However, only 13 bits of those two bytes are used to store the Temp data in two's complement format with the resolution of 0.03125 °C. [Table 7](#) shows the bit arrangement of the Temp data in the data bytes.

Table 7. Temp register

MSByte								LSByte							
7	6	5	4	3	2	1	0	7	6	5	4	3	2	1	0
D15	D14	D13	D12	D11	D10	D9	D8	D7	D6	D5	D4	D3	D2	D1	D0

When reading register Temp, all 16 bits of the two data bytes (MSByte and LSByte) must be collected and then the two's complement data value according to the desired resolution must be selected for the temperature calculation. [Table 8](#) shows the example for 11-bit two's complement data value, [Table 9](#) shows the example for 13-bit two's complement data value.

Table 8. Example 11-bit two's complement Temp register

MSByte								LSByte							
7	6	5	4	3	2	1	0	7	6	5	4	3	2	1	0
D10	D9	D8	D7	D6	D5	D4	D3	D2	D1	D0	X	X	X	X	X

Table 9. Example 13-bit two's complement register

MSByte								LSByte							
7	6	5	4	3	2	1	0	7	6	5	4	3	2	1	0
D12	D11	D10	D9	D8	D7	D6	D5	D4	D3	D2	D1	D0	X	X	X

When converting into the temperature the proper resolution must be used as listed in [Table 10](#) using either one of these two formulae:

1. If the Temp data MSB = 0, then: $\text{Temp } (^{\circ}\text{C}) = +(\text{Temp data}) \times \text{value resolution}$
2. If the Temp data MSB = 1, then: $\text{Temp } (^{\circ}\text{C}) = -(\text{two's complement Temp data}) \times \text{value resolution}$

Table 10. Temp data and Temp value resolution

Data resolution	Value resolution
8 bit	1.0 °C
9 bit	0.5 °C
10 bit	0.25 °C
11 bit	0.125 °C
12 bit	0.0625 °C
13 bit	0.03125 °C

[Table 11](#) shows some examples of the results for the 11-bit calculations.

Table 11. Temp register value

11-bit binary (two's complement)	Hexadecimal value	Decimal value	Value
011 1111 1000	3F8	1016	+127.000 °C
011 1111 0111	3F7	1015	+126.875 °C
011 1111 0001	3F1	1009	+126.125 °C
011 1110 1000	3E8	1000	+125.000 °C
000 1100 1000	0C8	200	+25.000 °C
000 0000 0001	001	1	+0.125 °C
000 0000 0000	000	0	0.000 °C
111 1111 1111	7FF	-1	-0.125 °C
111 0011 1000	738	-200	-25.000 °C
110 0100 1001	649	-439	-54.875 °C
110 0100 1000	648	-440	-55.000 °C

Obviously, for 9-bit Temp data application in replacing the industry standard LM75, just use only 9 MSB bits of the two bytes and disregard 7 LSB of the LSByte. The 9-bit Temp data with 0.5 °C resolution of the SE95 is defined exactly in the same way as for the standard LM75 and it is here similar to the Tos and Thyst registers.

8.6 Overtemperature shutdown threshold and hysteresis registers

These two registers, are write/read registers, and also called set-point registers. They are used to store the user-defined temperature limits, called overtemperature shutdown threshold (Tos) and hysteresis temperature (Thyst), for the device watchdog operation. At the end of each conversion the Temp data will be compared with the data stored in these two registers in order to set the state of the device OS output; see [Section 7.1](#).

Each of the set-point registers contains two 8-bit data bytes consisting of one MSByte and one LSByte the same as register Temp. However, only 9 bits of the two bytes are used to store the set-point data in two's complement format with the resolution of 0.5 °C. [Table 12](#) and [Table 13](#) show the bit arrangement of the Tos data and Thyst data in the data bytes.

Notice that because only 9-bit data are used in the set-point registers, the device uses only the 9 MSB of the Temp data for data comparison.

Table 12. Tos register

MSByte								LSByte							
7	6	5	4	3	2	1	0	7	6	5	4	3	2	1	0
D8	D7	D6	D5	D4	D3	D2	D1	D0	X	X	X	X	X	X	X

Table 13. Thyst register

MSByte								LSByte							
7	6	5	4	3	2	1	0	7	6	5	4	3	2	1	0
D8	D7	D6	D5	D4	D3	D2	D1	D0	X	X	X	X	X	X	X

When a set-point register is read, all 16 bits are provided to the bus and must be collected by the controller to complete the bus operation. However, only the 9 most significant bits should be used and the 7 LSB of the LSByte are equal to zero and should be ignored.

[Table 14](#) shows examples of the limit data and value.

Table 14. Tos and Thyst register

11-bit binary (two's complement)	Hexadecimal value	Decimal value	Value
0 1111 1010	0FA	250	125.0 °C
0 0011 0010	032	50	25.0 °C
0 0000 0001	001	1	0.5 °C
0 0000 0000	000	0	0.0 °C
1 1111 1111	1FF	-1	-0.5 °C
1 1100 1110	1CE	-50	-25.0 °C
1 1001 0010	192	-110	-55.0 °C

8.7 Protocols for writing and reading the registers

The communication between the host and the SE95 must follow the rules strictly as defined by the I²C-bus management. The protocols for SE95 register read/write operations are illustrated in [Figure 5](#) to [Figure 10](#) together with the following definitions:

1. Before a communication, the I²C-bus must be free or not busy. It means that the SCL and SDA lines must both be released by all devices on the bus, and they become HIGH by the bus pull-up resistors.
2. The host must provide SCL clock pulses necessary for the communication. Data is transferred in a sequence of 9 SCL clock pulses for every 8-bit data byte followed by 1-bit status of the acknowledgement.
3. During data transfer, except the START and STOP signals, the SDA signal must be stable while the SCL signal is HIGH. It means that the SDA signal can be changed only during the LOW duration of the SCL line.
4. S: START signal, initiated by the host to start a communication, the SDA goes from HIGH-to-LOW while the SCL is HIGH.
5. RS: RE-START signal, same as the START signal, to start a read command that follows a write command.
6. P: STOP signal, generated by the host to stop a communication, the SDA goes from LOW-to-HIGH while the SCL is HIGH. The bus becomes free thereafter.
7. W: write bit, when the write/read bit is in a write command.
8. R: read bit, when the write/read bit is logic 1 in a read command.
9. A: device acknowledge bit, returned by the SE95. It is logic 0 if the device works properly and logic 1 if not. The host must release the SDA line during this period in order to give the device the control on the SDA line.
10. A': master acknowledge bit, not returned by the device, but set by the master or host in reading 2-byte data. During this clock period, the host must set the SDA line to LOW in order to notify the device that the first byte has been read for the device to provide the second byte onto the bus.
11. NA: not-acknowledge bit. During this clock period, both the device and host release the SDA line at the end of a data transfer, the host is then enabled to generate the stop signal.
12. In a write protocol, data is sent from the host to the device and the host controls the SDA line, except during the clock period when the device sends the device acknowledgement signal to the bus.
13. In a read protocol, data is sent to the bus by the device and the host must release the SDA line during the time that the device is providing data onto the bus and controlling the SDA line, except during the clock period when the master sends the master acknowledgement signal to the bus.

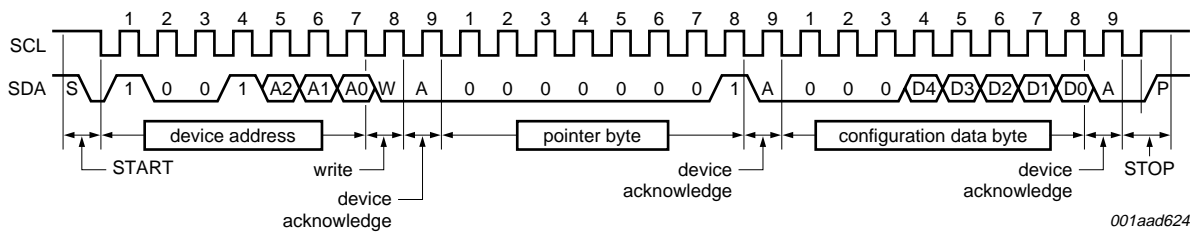

Fig 5. Write configuration register (1-byte data)

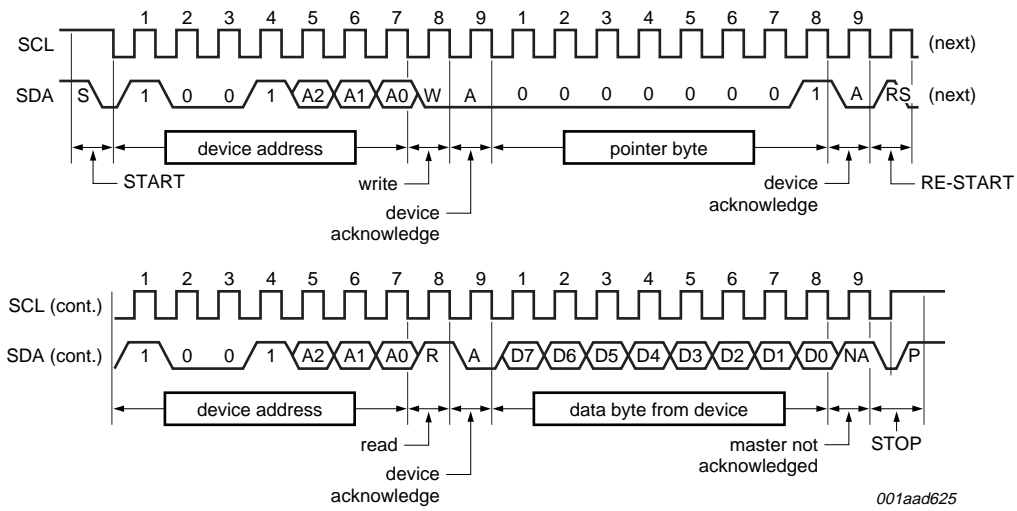

Fig 6. Read configuration register including pointer byte (1-byte data)

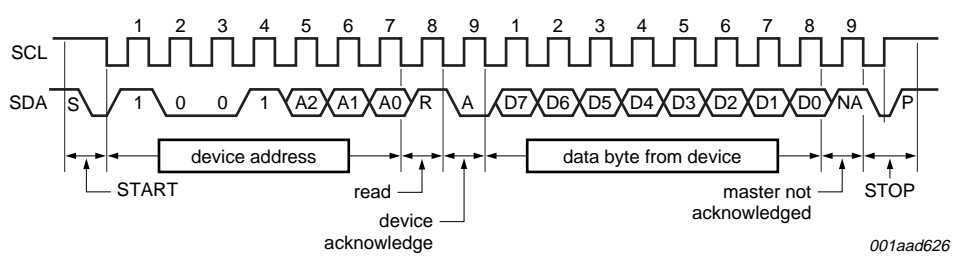

Fig 7. Read configuration register with preset pointer (1-byte data)

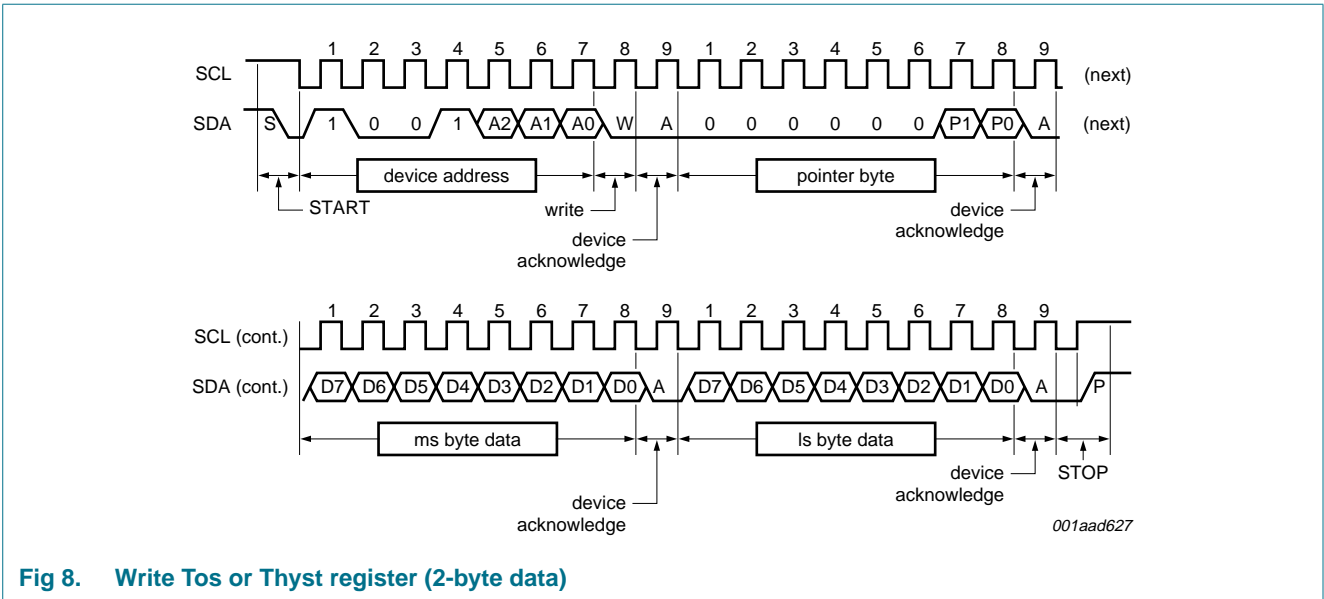

Fig 8. Write Tos or Thyst register (2-byte data)

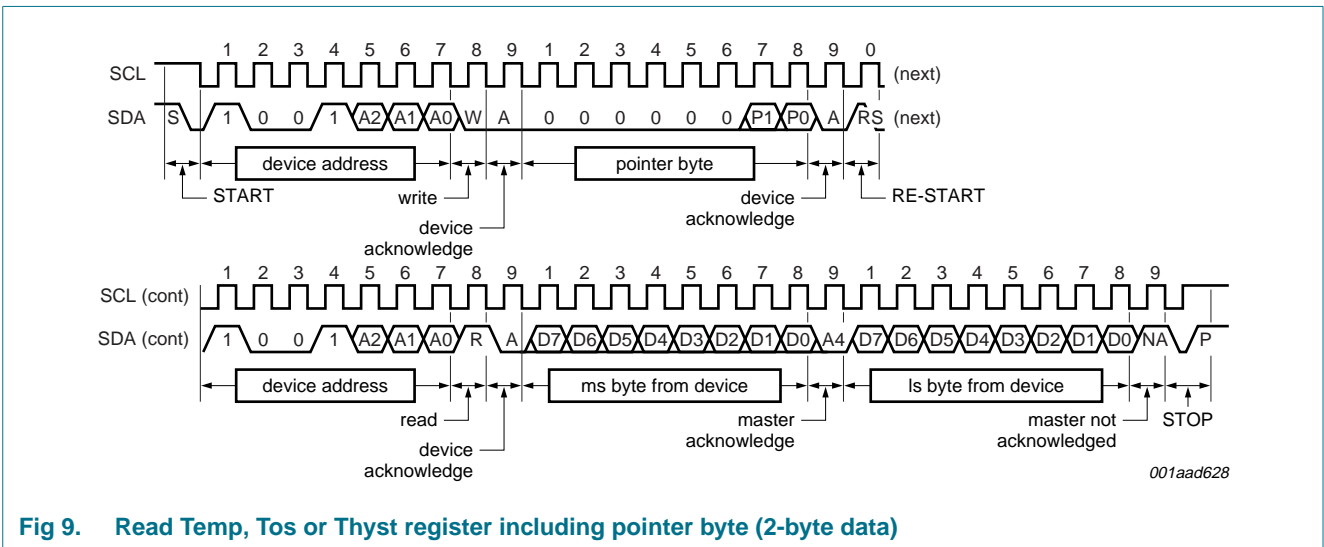

Fig 9. Read Temp, Tos or Thyst register including pointer byte (2-byte data)

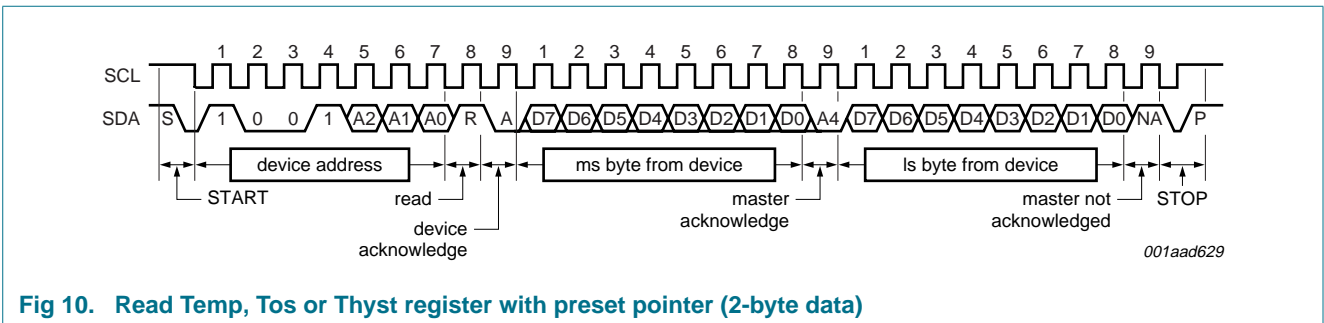

Fig 10. Read Temp, Tos or Thyst register with preset pointer (2-byte data)

9. Limiting values

Table 15. Limiting values

In accordance with the Absolute Maximum Rating System (IEC 60134).

Symbol	Parameter	Conditions	Min	Max	Unit
V_{CC}	supply voltage		-0.3	+6.0	V
$V_{I(SCL)}$	input voltage on pin SCL		-0.3	+6.0	V
$V_{I(SDA)}$	input voltage on pin SDA		-0.3	+6.0	V
$V_{I(A0)}$	input voltage on pin A0		-3.0	$V_{CC} + 0.3$	V
$V_{I(A1)}$	input voltage on pin A1		-3.0	$V_{CC} + 0.3$	V
$V_{I(A2)}$	input voltage on pin A2		-3.0	$V_{CC} + 0.3$	V
$I_{I(PIN)}$	input current on input pins		-5.0	+5.0	mA
$I_{O(OS)}$	output current on pin OS		-	10.0	mA
$V_{O(OS)}$	output voltage on pin OS		-0.3	+6.0	V
V_{ESD}	electrostatic discharge voltage	human body model	-	1000	V
		machine model	-	150	V
T_{stg}	storage temperature		-65	+150	°C
T_j	junction temperature		-	150	°C

10. Recommended operating conditions

Table 16. Recommended operating characteristics

Symbol	Parameter	Conditions	Min	Typ	Max	Unit
V_{CC}	supply voltage		2.8	-	5.5	V
T_{amb}	ambient temperature		-55	-	+125	°C

11. Static characteristics

Table 17. Static characteristics

$V_{CC} = 2.8\text{ V to }5.5\text{ V}$, $T_{amb} = -55\text{ °C to }+125\text{ °C}$; unless otherwise specified.

Symbol	Parameter	Conditions	Min	Typ ^[1]	Max	Unit
T_{acc}	temperature accuracy	$V_{CC} = 2.8\text{ V to }3.6\text{ V}$	[2]			
		$T_{amb} = -25\text{ °C to }+100\text{ °C}$	-1.0	-	+1.0	°C
		$T_{amb} = -55\text{ °C to }+125\text{ °C}$	-2.0	-	+2.0	°C
		$V_{CC} = 3.6\text{ V to }5.5\text{ V}$	[2]			
		$T_{amb} = -25\text{ °C to }+100\text{ °C}$	-2	-	+2	°C
		$T_{amb} = -55\text{ °C to }+125\text{ °C}$	-3	-	+3	°C
T_{res}	temperature resolution	11-bit digital temperature data	-	0.125	-	°C
$t_{conv(T)}$	temperature conversion time	normal mode	-	33	-	ms
I_{CC}	supply current	normal mode: I ² C-bus inactive	-	150	-	µA
		normal mode: I ² C-bus active	-	-	1.0	mA
		shutdown mode	-	7.5	-	µA
V_{IH}	HIGH-level input voltage	digital pins	[3] $0.7V_{CC}$	-	$V_{CC} + 0.3$	V
V_{IL}	LOW-level input voltage	digital pins	[3] -0.3	-	$+0.3V_{CC}$	V
$V_{I(hys)}$	hysteresis of input voltage	pins SCL and SDA	-	300	-	mV
		pins A2 to A0	-	300	-	mV
I_{IH}	HIGH-level input current	digital pins; $V_{IN} = V_{CC}$	[3] -1.0	-	+1.0	µA
I_{IL}	LOW-level input current	digital pins; $V_{IN} = 0\text{ V}$	[3] -1.0	-	+1.0	µA
V_{OL}	LOW-level output voltage	pins SDA and OS; $I_{OL} = 3\text{ mA}$	-	-	0.4	V
		$I_{OL} = 4\text{ mA}$	-	-	0.8	V
I_{LO}	output leakage current	pins SDA and OS; $V_{OH} = V_{CC}$	-	-	10	µA
V_{POR}	power-on reset voltage	V_{CC} supply below which the logic is reset	1.0	-	2.5	V
OSQ	OS fault queue	programmable	[4] 1	-	6	
T_{os}	overtemperature shutdown threshold	default value	-	80	-	°C
f_{sam}	sampling rate	programmable	0.125	10	30	sample/s
T_{hyst}	hysteresis temperature	default value	-	75	-	°C
C_i	input capacitance	digital pins	-	20	-	pF

[1] Typical values are at $V_{CC} = 3.3\text{ V}$ and $T_{amb} = 25\text{ °C}$.

[2] Assumes a minimum 11-bit temperature reading.

[3] The digital pins are pin SCL, SDA and A2 to A0.

[4] Device analog-to-digital conversion.

12. Dynamic characteristics

Table 18. Dynamic characteristics^[1]

$V_{CC} = 2.8\text{ V to }5.5\text{ V}$, $T_{amb} = -55\text{ }^{\circ}\text{C to }+125\text{ }^{\circ}\text{C}$; unless otherwise specified.

Symbol	Parameter	Conditions	Min	Typ	Max	Unit
T_{CLK}	SCL clock period	see Figure 11	2.5	-	-	μs
$t_{(SCL)H}$	HIGH period of the SCL clock		0.6	-	-	μs
$t_{(SCL)L}$	LOW period of the SCL clock		1.3	-	-	μs
$t_{HD;STA}$	hold time (repeated) START condition		100	-	-	ns
$t_{SU;DAT}$	data set-up time		100	-	-	ns
$t_{HD;DAT}$	data hold time		0	-	-	ns
$t_{SU;STO}$	set-up time for STOP condition		100	-	-	ns
t_f	fall time	pins SDA and OS; $C_L = 400\text{ pF}$; $I_{OL} = 3\text{ mA}$	-	250	-	ns

[1] These specifications are guaranteed by design and not tested in production.

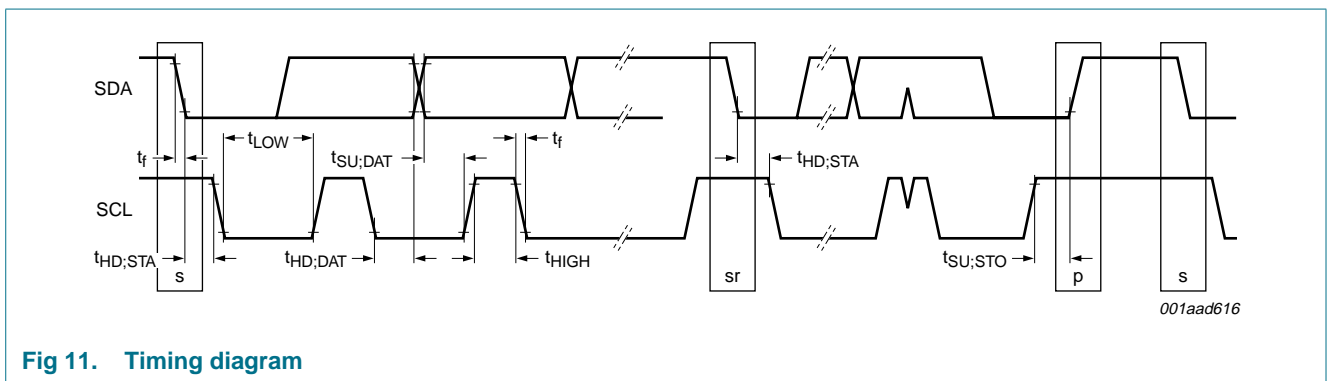

Fig 11. Timing diagram

13. Performance curves

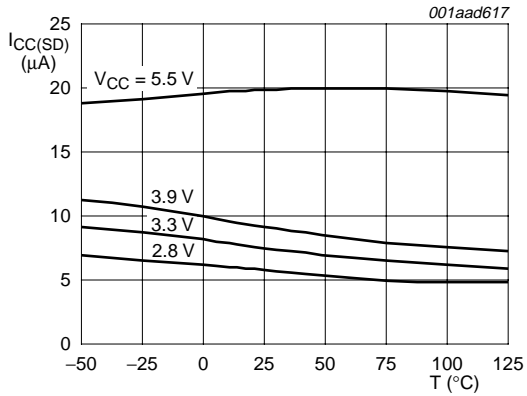

Fig 12. Shutdown supply current as a function of temperature

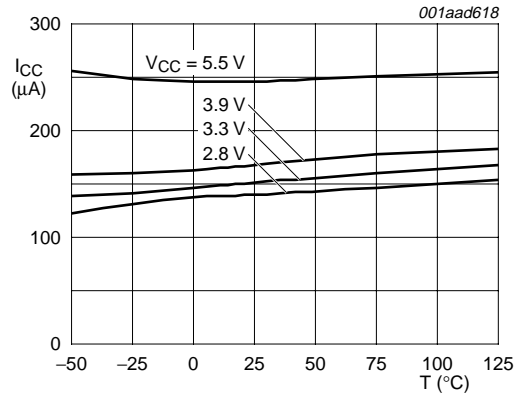

Fig 13. Typical normal I²C-bus inactive supply current as a function of temperature

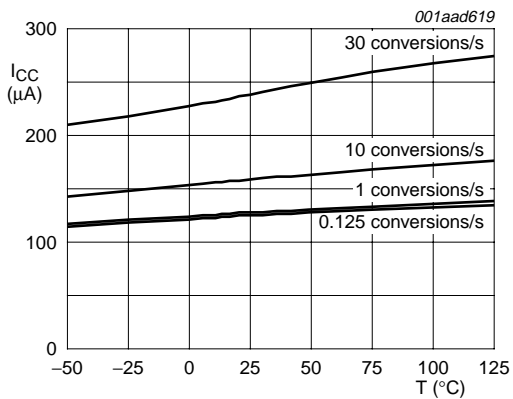

Fig 14. Typical normal I²C-bus inactive supply current as a function of temperature

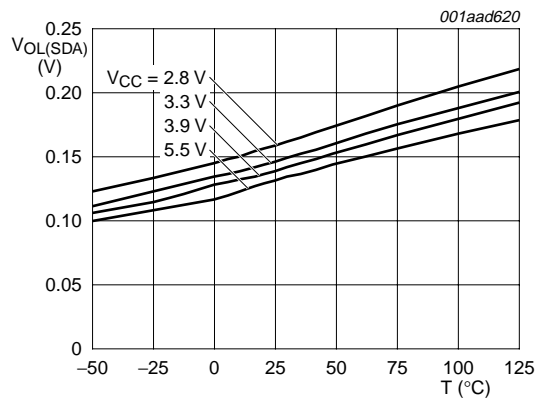

Fig 15. Typical SDA V_{OL} as a function of temperature

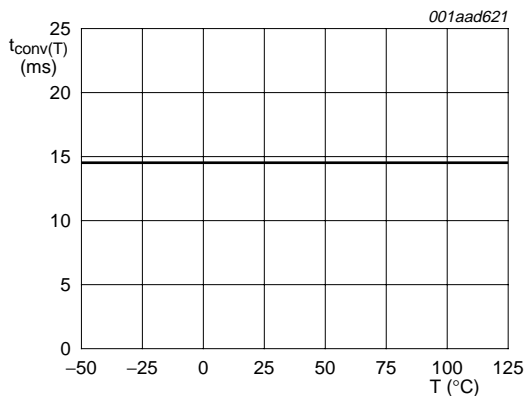

Fig 16. Typical conversion time as a function of temperature

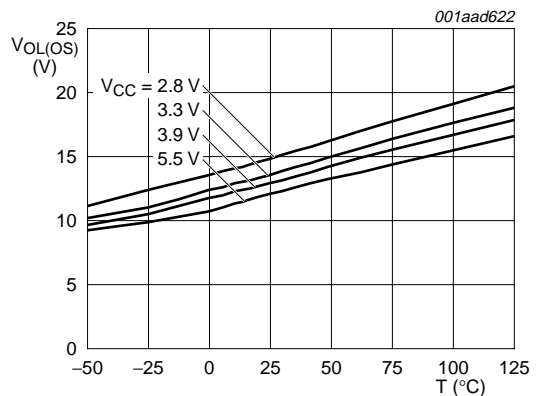

Fig 17. Typical OS V_{OL} as a function of temperature

14. Application information

The SE95 is sensitive to power supplies with ramp-up time ≤ 2 ms and could NACK or hang the I²C-bus. In most applications the SE95 will function properly since power supplies have a > 2 ms ramp-up time. If the power supply ramp-up time is ≤ 2 ms, use an RC network with $R = 300 \Omega$ and $C = 10 \mu\text{F}$, as shown in [Figure 18](#), to add about 3 ms to the ramp-up time. The $10 \mu\text{F}$ capacitor is the same as the bypass capacitor that is typically used to prevent fluctuations on the power supply. The 300Ω resistor will reduce the supply voltage by about 45 mV since the SE95 supply current is about $150 \mu\text{A}$. Ensure the SE95 is the only device connected to the end of 300Ω resistor since additional devices would draw more current and cause a larger voltage drop across the resistor.

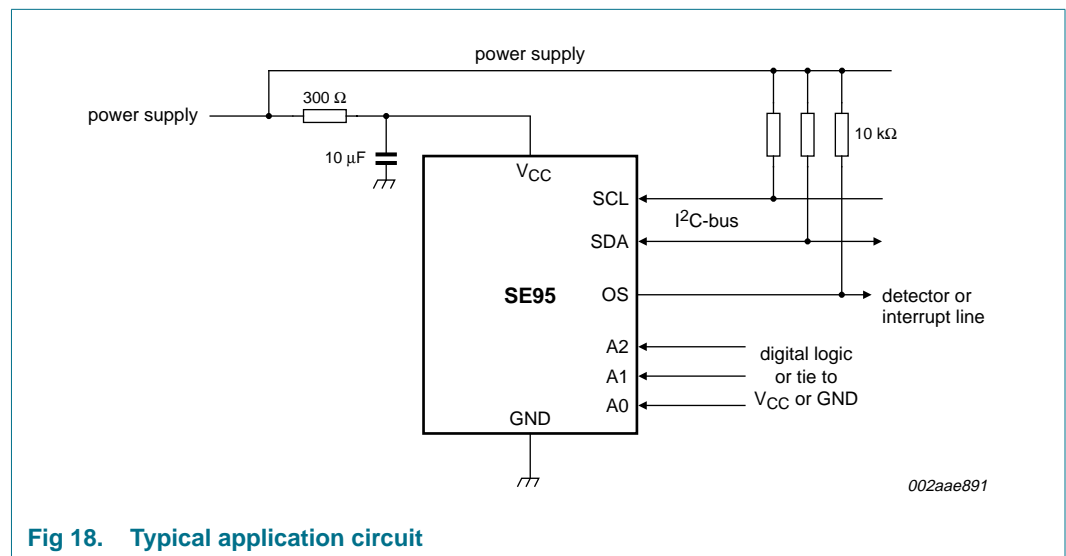

Fig 18. Typical application circuit

15. Package outline

SO8: plastic small outline package; 8 leads; body width 3.9 mm

SOT96-1

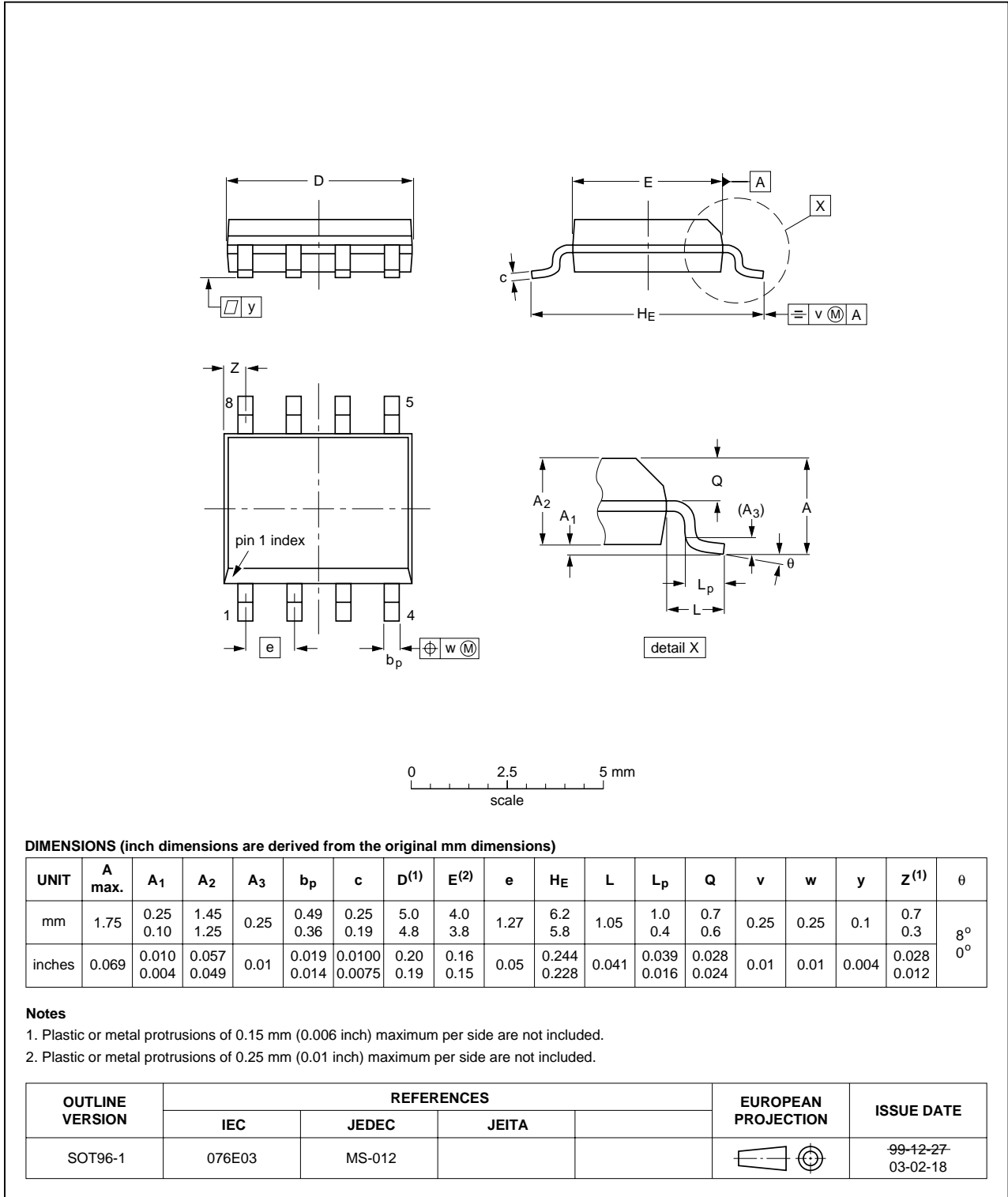

Fig 19. Package outline SOT96-1 (SO8)

TSSOP8: plastic thin shrink small outline package; 8 leads; body width 3 mm

SOT505-1

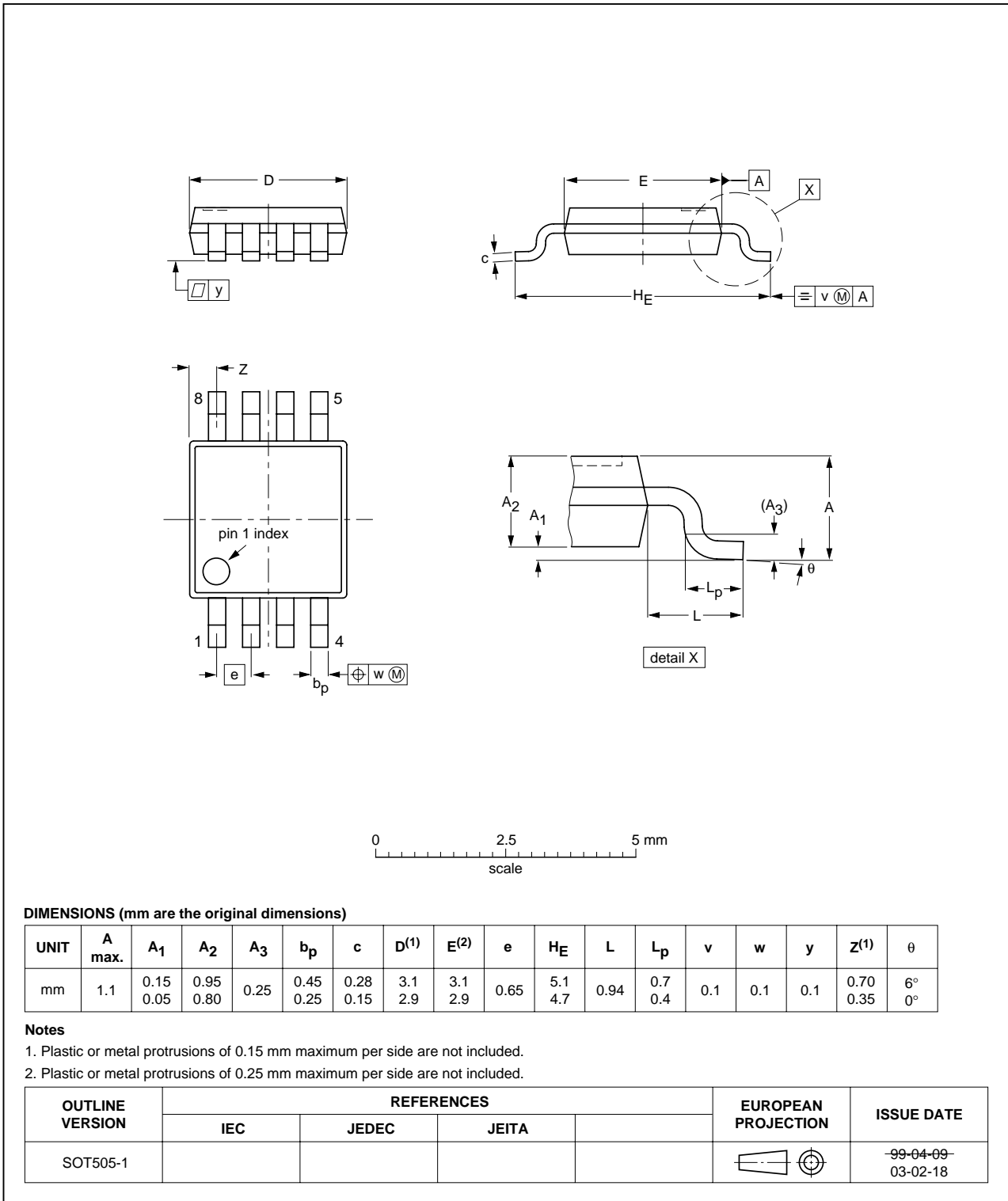

Fig 20. Package outline SOT505-1 (TSSOP8)

16. Soldering of SMD packages

This text provides a very brief insight into a complex technology. A more in-depth account of soldering ICs can be found in Application Note *AN10365 "Surface mount reflow soldering description"*.

16.1 Introduction to soldering

Soldering is one of the most common methods through which packages are attached to Printed Circuit Boards (PCBs), to form electrical circuits. The soldered joint provides both the mechanical and the electrical connection. There is no single soldering method that is ideal for all IC packages. Wave soldering is often preferred when through-hole and Surface Mount Devices (SMDs) are mixed on one printed wiring board; however, it is not suitable for fine pitch SMDs. Reflow soldering is ideal for the small pitches and high densities that come with increased miniaturization.

16.2 Wave and reflow soldering

Wave soldering is a joining technology in which the joints are made by solder coming from a standing wave of liquid solder. The wave soldering process is suitable for the following:

- Through-hole components
- Leaded or leadless SMDs, which are glued to the surface of the printed circuit board

Not all SMDs can be wave soldered. Packages with solder balls, and some leadless packages which have solder lands underneath the body, cannot be wave soldered. Also, leaded SMDs with leads having a pitch smaller than ~0.6 mm cannot be wave soldered, due to an increased probability of bridging.

The reflow soldering process involves applying solder paste to a board, followed by component placement and exposure to a temperature profile. Leaded packages, packages with solder balls, and leadless packages are all reflow solderable.

Key characteristics in both wave and reflow soldering are:

- Board specifications, including the board finish, solder masks and vias
- Package footprints, including solder thieves and orientation
- The moisture sensitivity level of the packages
- Package placement
- Inspection and repair
- Lead-free soldering versus SnPb soldering

16.3 Wave soldering

Key characteristics in wave soldering are:

- Process issues, such as application of adhesive and flux, clinching of leads, board transport, the solder wave parameters, and the time during which components are exposed to the wave
- Solder bath specifications, including temperature and impurities

16.4 Reflow soldering

Key characteristics in reflow soldering are:

- Lead-free versus SnPb soldering; note that a lead-free reflow process usually leads to higher minimum peak temperatures (see [Figure 21](#)) than a SnPb process, thus reducing the process window
- Solder paste printing issues including smearing, release, and adjusting the process window for a mix of large and small components on one board
- Reflow temperature profile; this profile includes preheat, reflow (in which the board is heated to the peak temperature) and cooling down. It is imperative that the peak temperature is high enough for the solder to make reliable solder joints (a solder paste characteristic). In addition, the peak temperature must be low enough that the packages and/or boards are not damaged. The peak temperature of the package depends on package thickness and volume and is classified in accordance with [Table 19](#) and [20](#)

Table 19. SnPb eutectic process (from J-STD-020C)

Package thickness (mm)	Package reflow temperature (°C)	
	Volume (mm ³)	
	< 350	≥ 350
< 2.5	235	220
≥ 2.5	220	220

Table 20. Lead-free process (from J-STD-020C)

Package thickness (mm)	Package reflow temperature (°C)		
	Volume (mm ³)		
	< 350	350 to 2000	> 2000
< 1.6	260	260	260
1.6 to 2.5	260	250	245
> 2.5	250	245	245

Moisture sensitivity precautions, as indicated on the packing, must be respected at all times.

Studies have shown that small packages reach higher temperatures during reflow soldering, see [Figure 21](#).

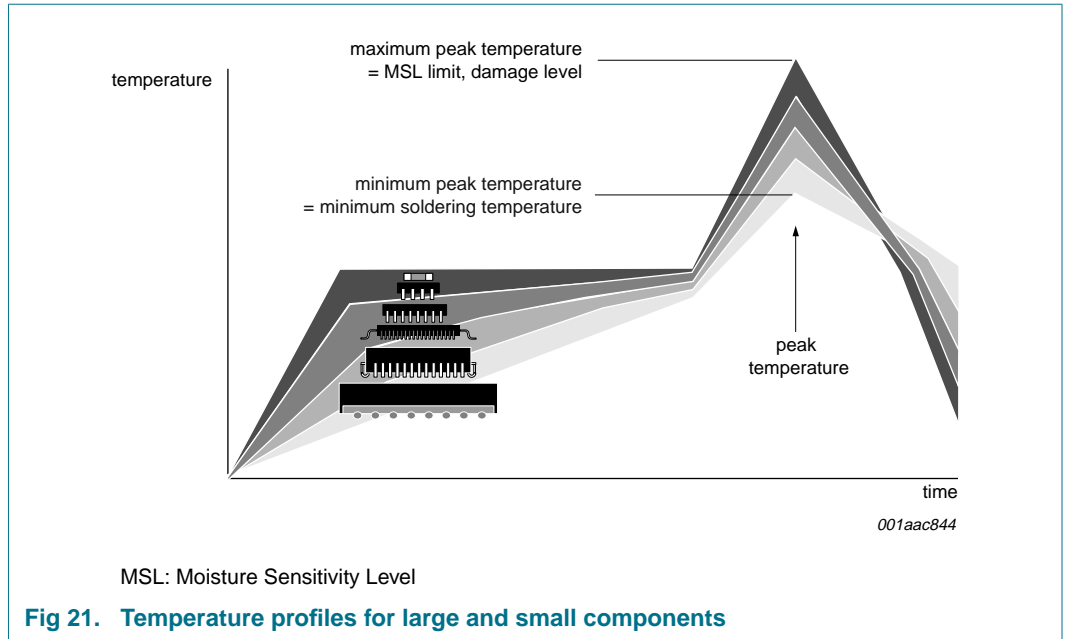

Fig 21. Temperature profiles for large and small components

For further information on temperature profiles, refer to Application Note AN10365 “Surface mount reflow soldering description”.

17. Abbreviations

Table 21. Abbreviations

Acronym	Description
ADC	Analog-to-Digital Converter
ESD	ElectroStatic Discharge
HBM	Human Body Model
I ² C-bus	Inter-Integrated Circuit bus
I/O	Input/Output
LSB	Least Significant Bit
LSByte	Least Significant Byte
MM	Machine Model
MSB	Most Significant Bit
MSByte	Most Significant Byte
OTP	One-Time Programmable
POR	Power-On Reset
SMBus	System Management Bus

18. Revision history

Table 22. Revision history

Document ID	Release date	Data sheet status	Change notice	Supersedes
SE95_7	20090902	Product data sheet	-	SE95_6
Modifications:	<ul style="list-style-type: none"> • Figure 1 “Block diagram of SE95”: changed from “AVD CONTOL” to “ADC CONTROL” • Section 14 “Application information”: <ul style="list-style-type: none"> – Added first paragraph – Figure 18 “Typical application circuit” modified • Added soldering information • Added Section 17 “Abbreviations” 			
SE95_6	20090604	Product data sheet	-	SE95_5
SE95_5	20071213	Product data sheet	-	SE95_4
SE95_4	20070212	Product data sheet	-	SE95_3
SE95_3 (9397 750 14388)	20051212	Product data sheet	-	SE95_2
SE95_2 (9397 750 14163)	20041005	Objective specification	-	SE95_1
SE95_1 (9397 750 10265)	20031003	Objective specification	-	-

19. Legal information

19.1 Data sheet status

Document status ^{[1][2]}	Product status ^[3]	Definition
Objective [short] data sheet	Development	This document contains data from the objective specification for product development.
Preliminary [short] data sheet	Qualification	This document contains data from the preliminary specification.
Product [short] data sheet	Production	This document contains the product specification.

[1] Please consult the most recently issued document before initiating or completing a design.

[2] The term 'short data sheet' is explained in section "Definitions".

[3] The product status of device(s) described in this document may have changed since this document was published and may differ in case of multiple devices. The latest product status information is available on the Internet at URL <http://www.nxp.com>.

19.2 Definitions

Draft — The document is a draft version only. The content is still under internal review and subject to formal approval, which may result in modifications or additions. NXP Semiconductors does not give any representations or warranties as to the accuracy or completeness of information included herein and shall have no liability for the consequences of use of such information.

Short data sheet — A short data sheet is an extract from a full data sheet with the same product type number(s) and title. A short data sheet is intended for quick reference only and should not be relied upon to contain detailed and full information. For detailed and full information see the relevant full data sheet, which is available on request via the local NXP Semiconductors sales office. In case of any inconsistency or conflict with the short data sheet, the full data sheet shall prevail.

19.3 Disclaimers

General — Information in this document is believed to be accurate and reliable. However, NXP Semiconductors does not give any representations or warranties, expressed or implied, as to the accuracy or completeness of such information and shall have no liability for the consequences of use of such information.

Right to make changes — NXP Semiconductors reserves the right to make changes to information published in this document, including without limitation specifications and product descriptions, at any time and without notice. This document supersedes and replaces all information supplied prior to the publication hereof.

Suitability for use — NXP Semiconductors products are not designed, authorized or warranted to be suitable for use in medical, military, aircraft, space or life support equipment, nor in applications where failure or malfunction of an NXP Semiconductors product can reasonably be expected to result in personal injury, death or severe property or environmental

damage. NXP Semiconductors accepts no liability for inclusion and/or use of NXP Semiconductors products in such equipment or applications and therefore such inclusion and/or use is at the customer's own risk.

Applications — Applications that are described herein for any of these products are for illustrative purposes only. NXP Semiconductors makes no representation or warranty that such applications will be suitable for the specified use without further testing or modification.

Limiting values — Stress above one or more limiting values (as defined in the Absolute Maximum Ratings System of IEC 60134) may cause permanent damage to the device. Limiting values are stress ratings only and operation of the device at these or any other conditions above those given in the Characteristics sections of this document is not implied. Exposure to limiting values for extended periods may affect device reliability.

Terms and conditions of sale — NXP Semiconductors products are sold subject to the general terms and conditions of commercial sale, as published at <http://www.nxp.com/profile/terms>, including those pertaining to warranty, intellectual property rights infringement and limitation of liability, unless explicitly otherwise agreed to in writing by NXP Semiconductors. In case of any inconsistency or conflict between information in this document and such terms and conditions, the latter will prevail.

No offer to sell or license — Nothing in this document may be interpreted or construed as an offer to sell products that is open for acceptance or the grant, conveyance or implication of any license under any copyrights, patents or other industrial or intellectual property rights.

Export control — This document as well as the item(s) described herein may be subject to export control regulations. Export might require a prior authorization from national authorities.

19.4 Trademarks

Notice: All referenced brands, product names, service names and trademarks are the property of their respective owners.

I²C-bus — logo is a trademark of NXP B.V.

20. Contact information

For more information, please visit: <http://www.nxp.com>

For sales office addresses, please send an email to: salesaddresses@nxp.com

21. Contents

1	General description	1	20	Contact information	26
2	Features	2	21	Contents	27
3	Applications	2			
4	Ordering information	2			
5	Block diagram	3			
6	Pinning information	3			
6.1	Pinning	3			
6.2	Pin description	3			
7	Functional description	4			
7.1	General operation	4			
7.2	OS output and polarity	6			
7.3	OS comparator and interrupt modes	6			
7.4	OS fault queue	6			
7.5	Shutdown mode	7			
7.6	Power-up default and power-on reset	7			
8	I²C-bus serial interface	7			
8.1	Slave address	7			
8.2	Register list	8			
8.3	Register pointer	8			
8.4	Configuration register	9			
8.5	Temperature register	9			
8.6	Overtemperature shutdown threshold and hysteresis registers	11			
8.7	Protocols for writing and reading the registers	12			
9	Limiting values	15			
10	Recommended operating conditions	15			
11	Static characteristics	16			
12	Dynamic characteristics	17			
13	Performance curves	18			
14	Application information	19			
15	Package outline	20			
16	Soldering of SMD packages	22			
16.1	Introduction to soldering	22			
16.2	Wave and reflow soldering	22			
16.3	Wave soldering	22			
16.4	Reflow soldering	23			
17	Abbreviations	24			
18	Revision history	25			
19	Legal information	26			
19.1	Data sheet status	26			
19.2	Definitions	26			
19.3	Disclaimers	26			
19.4	Trademarks	26			

Please be aware that important notices concerning this document and the product(s) described herein, have been included in section 'Legal information'.



© NXP B.V. 2009.

All rights reserved.

For more information, please visit: <http://www.nxp.com>

For sales office addresses, please send an email to: salesaddresses@nxp.com

Date of release: 2 September 2009

Document identifier: SE95_7