



PCA85132

LCD driver for low multiplex rates

Rev. 3 — 11 July 2013

Product data sheet

1. General description

The PCA85132 is a peripheral device which interfaces to almost any Liquid Crystal Display (LCD)¹ with low multiplex rates. It generates the drive signals for any static or multiplexed LCD containing up to four backplanes and up to 160 segments. It can easily be cascaded for larger LCD applications. The PCA85132 is compatible with most microcontrollers and communicates via the two-line bidirectional I²C-bus. Communication overheads are minimized by a display RAM with auto-incremental addressing, by hardware subaddressing, and by display memory switching (static and duplex drive modes).

2. Features and benefits

- AEC-Q100 compliant for automotive applications
- Single-chip LCD controller and driver for up to 640 elements
- Selectable backplane drive configuration: static, 2, 3, or 4 backplane multiplexing
- 160 segment drives:
 - ◆ Up to 80 7-segment numeric characters
 - ◆ Up to 40 14-segment alphanumeric characters
 - ◆ Any graphics of up to 640 elements
- May be cascaded for large LCD applications (up to 5120 elements possible)
- 160 × 4-bit RAM for display data storage
- Software programmable frame frequency in steps of 5 Hz in the range of 60 Hz to 90 Hz; factory calibrated
- Wide LCD supply range: from 1.8 V for low threshold LCDs and up to 8.0 V for guest-host LCDs and high threshold (automobile) twisted nematic LCDs
- Internal LCD bias generation with voltage-follower buffers
- Selectable display bias configuration: static, 1/2, or 1/3
- Wide power supply range: from 1.8 V to 5.5 V
- LCD and logic supplies may be separated
- Low power consumption, typical: I_{DD} = 4 μA, I_{DD(LCD)} = 30 μA
- 400 kHz I²C-bus interface
- Auto-incremental display data loading across device subaddress boundaries
- Versatile blinking modes
- Compatible with Chip-On-Glass (COG) technology
- No external components required
- Two sets of backplane outputs for optimal COG configurations of the application

1. The definition of the abbreviations and acronyms used in this data sheet can be found in [Section 18 on page 55](#).



3. Ordering information

Table 1. Ordering information

Type number	Package		
	Name	Description	Version
PCA85132U	bare die	197 bumps; 6.5 × 1.16 × 0.40 mm	PCA85132U

3.1 Ordering options

Table 2. Ordering options

Product type number	IC revision	Sales item (12NC)	Delivery form
PCA85132U/2DA/Q1	1	935290542026	chips with hard bumps ^[1] in tray
PCA85132U/2DB/Q1	1	935290543026	chips with soft bumps ^[1] in tray

[1] Bump hardness see [Table 28 on page 53](#).

4. Marking

Table 3. Marking codes

Product type number	Marking code
PCA85132U/2DA/Q1	PC85132/232-1
PCA85132U/2DB/Q1	PC85132/232-1

6.2 Pin description

Table 4. Pin description

Symbol	Pin	Description
SDAACK ^[1]	1 to 3	I ² C-bus acknowledge output
SDA ^[1]	4 to 6	I ² C-bus serial data input
SCL	7 to 9	I ² C-bus serial clock input
CLK	10	clock input and output
V _{DD}	11 to 13	supply voltage
SYNC	14	cascade synchronization input and output
OSC	15	selection of internal or external clock
T1, T2, and T3	16, 17, and 18 to 20	dedicated testing pins; to be tied to V _{SS} in application mode
A0 and A1	21, 22	subaddress inputs
SA0	23	I ² C-bus slave address input
V _{SS} ^[2]	24 to 26	ground supply voltage
V _{LCD}	27 to 29	LCD supply voltage
BP2 and BP0	30, 31	LCD backplane outputs
S0 to S79	32 to 111	LCD segment outputs
BP0, BP2, BP1, and BP3	112 to 115	LCD backplane outputs
S80 to S159	116 to 195	LCD segment outputs
BP3 and BP1	196, 197	LCD backplane outputs

[1] For most applications SDA and SDAACK are shorted together (see [Section 14.3 on page 44](#)).

[2] The substrate (rear side of the die) is connected to V_{SS} and should be electrically isolated.

7. Functional description

The PCA85132 is a versatile peripheral device designed to interface between any microcontroller to a wide variety of LCD segment or dot matrix displays. It can directly drive any static or multiplexed LCD containing up to four backplanes and up to 160 segments.

7.1 Commands of PCA85132

The commands available to the PCA85132 are defined in [Table 5](#).

Table 5. Definition of PCA85132 commands

Command	Operation code								Reference
	7	6	5	4	3	2	1	0	
mode-set	1	1	0	0	E	B	M[1:0]		Table 6
load-data-pointer-MSB	0	0	0	0	P[7:4]				Table 7
load-data-pointer-LSB	0	1	0	0	P[3:0]				Table 8
device-select	1	1	1	0	0	0	A[1:0]		Table 9
bank-select	1	1	1	1	1	0	I	O	Table 10
blink-select	1	1	1	1	0	AB	BF[1:0]		Table 11
frequency-ctrl	1	1	1	0	1	F[2:0]			Table 12

7.1.1 Command: mode-set

The mode-set command allows configuring the multiplex mode, the bias levels and enabling or disabling the display.

Table 6. Mode-set - command bit description

Bit	Symbol	Value	Description
7 to 4	-	1100	fixed value
3	E		display status ^[1]
		0 ^[2]	disabled (blank) ^[3]
		1	enabled
2	B		LCD bias configuration ^[4]
		0 ^[2]	1/3 bias
		1	1/2 bias
1 to 0	M[1:0]		LCD drive mode selection
		01	static; BP0
		10	1:2 multiplex; BP0, BP1
		11	1:3 multiplex; BP0, BP1, BP2
		00 ^[2]	1:4 multiplex; BP0, BP1, BP2, BP3

[1] The possibility to disable the display allows implementation of blinking under external control. The enable bit determines also whether the internal clock signal is available at the CLK pin (see [Section 7.1.6.2 on page 9](#)).

[2] Default value.

[3] The display is disabled by setting all backplane and segment outputs to V_{LCD}.

[4] Not applicable for static drive mode.

7.1.2 Command: load-data-pointer

The load-data-pointer command defines the display RAM address where the following display data will be sent to.

Table 7. Load-data-pointer-MSB - command bit description

See [Section 7.5.1 on page 24](#).

Bit	Symbol	Value	Description
7 to 4	-	0000	fixed value
3 to 0	P[7:4]	0000 ^[1] to 1001	defines the first 4 (most significant) bits of the data-pointer the data-pointer indicates one of the 160 display RAM addresses

[1] Default value.

Table 8. Load-data-pointer-LSB - command bit description

See [Section 7.5.1 on page 24](#).

Bit	Symbol	Value	Description
7 to 4	-	0100	fixed value
3 to 0	P[3:0]	0000 ^[1] to 1111	defines the last 4 (least significant) bits of the data-pointer the data-pointer indicates one of the 160 display RAM addresses

[1] Default value.

7.1.3 Command: device-select

The device-select command allows defining the subaddress counter value.

Table 9. Device-select - command bit description

See [Section 7.5.2 on page 24](#).

Bit	Symbol	Value	Description
7 to 2	-	111000	fixed value
1 to 0	A[1:0]	00 ^[1] to 11	defines one of four hardware subaddresses (see Table 23 on page 44)

[1] Default value.

7.1.4 Command: bank-select

The bank-select command controls where data is written to RAM and where it is displayed from.

Table 10. Bank-select - command bit description

See [Section 7.5.4 on page 25](#).

Bit	Symbol	Value	Description	
			Static	1:2 multiplex ^[1]
7 to 2	-	111110	fixed value	
1	I		input bank selection ; storage of arriving display data	
		0 ^[2]	RAM row 0	RAM rows 0 and 1
		1	RAM row 2	RAM rows 2 and 3
0	O		output bank selection ; retrieval of LCD display data	
		0 ^[2]	RAM row 0	RAM rows 0 and 1
		1	RAM row 2	RAM rows 2 and 3

[1] The bank-select command has no effect in 1:3 and 1:4 multiplex drive modes.

[2] Default value.

7.1.5 Command: blink-select

The blink-select command allows configuring the blink mode and the blink frequency.

Table 11. Blink-select - command bit description

See [Section 7.1.6.6 on page 10](#).

Bit	Symbol	Value	Description
7 to 3	-	11110	fixed value
2	AB		blink mode selection
		0 ^[1]	normal blinking ^[2]
		1	alternate RAM bank blinking ^[3]
1 to 0	BF[1:0]		blink frequency selection
		00 ^[1]	off
		01	1
		10	2
		11	3

[1] Default value.

[2] Normal blinking is assumed when the LCD multiplex drive modes 1:3 or 1:4 are selected.

[3] Alternate RAM bank blinking does not apply in 1:3 and 1:4 multiplex drive modes.

7.1.6 Clock frequency and timing

The timing of the PCA85132 organizes the internal data flow of the device. The timing includes the transfer of display data from the display RAM to the display segment outputs and therefore the frame frequency.

7.1.6.1 Clock source selection

The PCA85132 can be configured to use either the built-in oscillator or an external clock as clock source:

Internal clock — To enable the internal oscillator, pin OSC has to be connected to V_{SS} . Pin CLK then becomes an output. For further information on the internal clock, see [Section 7.1.6.2](#).

External clock — To enable the use of an external clock, pin OSC has to be connected to V_{DD} . Pin CLK then becomes an input for the external clock frequency $f_{clk(ext)}$. For further information on the external clock, see [Section 7.1.6.3](#).

[Figure 3](#) illustrates the frequency generation of the PCA85132.

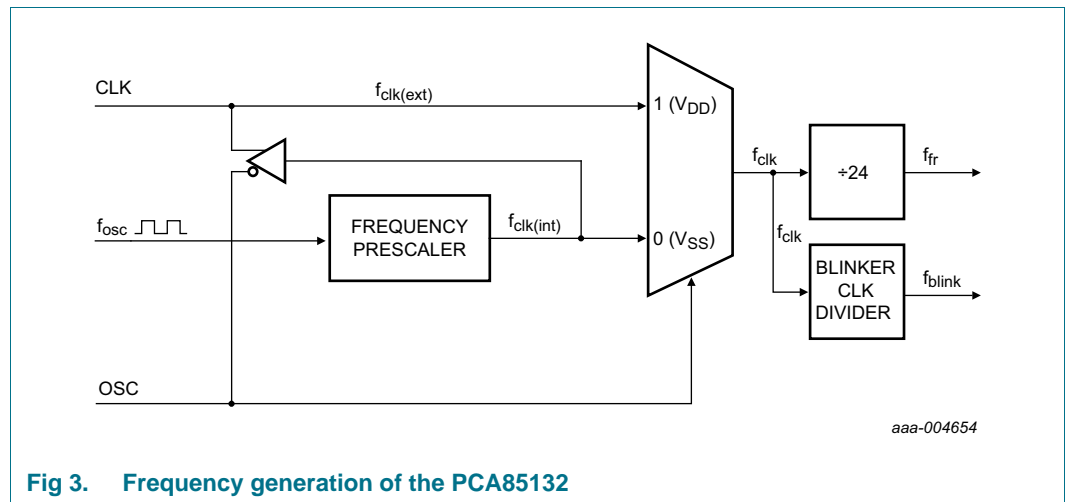

Fig 3. Frequency generation of the PCA85132

Remark: A clock signal must always be supplied to the device. Removing the clock may freeze the LCD in a DC state, which is not suitable for the liquid crystal.

7.1.6.2 Internal clock

If the internal oscillator is used, the timing of the PCA85132 is derived from the built-in oscillator by a pre-scaler which can be configured with the frequency-ctrl command (see [Table 12](#)).

The internal oscillator is calibrated within an accuracy of $\pm 3.9\%$ (at $V_{DD} = 5.0\text{ V}$; $T_{amb} = 30\text{ }^\circ\text{C}$).

The frequency-ctrl command determines the division factor between the oscillator frequency f_{osc} and the internal clock frequency $f_{clk(int)}$. If the internal oscillator is used, the frame frequency is derived from the internal clock frequency $f_{clk(int)}$ by the fixed division shown in [Equation 1 on page 10](#).

If the display is enabled (see bit E in [Table 6](#)), $f_{clk(int)}$ on pin CLK provides the clock signal for cascaded LCD drivers in the system. For further information about cascading, see [Section 14.4 on page 44](#). The value range of f_{osc} is specified in [Table 22 on page 38](#).

7.1.6.3 External clock

If the external clock source is selected, the timing frequency of the PCA85132 is the external clock frequency. In this case, the frequency-ctrl command has no influence on the clock frequency nor the frame frequency. The frame frequency is derived from the external clock frequency $f_{clk(ext)}$ by the fixed division as shown in [Equation 1](#).

7.1.6.4 Frame frequency

Sourced by the internal oscillator or an external clock, the frame frequency is derived from the clock frequency f_{clk} by [Equation 1](#).

$$f_{fr} = \frac{f_{clk}}{24} \tag{1}$$

7.1.6.5 Command: frequency-ctrl

Table 12. Frequency-ctrl - command bit description

Bit	Symbol	Value	Description		
			Equation	Nominal clock frequency ^[1]	Nominal frame frequency ^[1]
7 to 4	-	11101	fixed value		
3 to 0	F[2:0]		defines the division factor		
		000	$f_{clk(int)} = \frac{64}{80} \times f_{osc}$	1440 Hz	60 Hz
		001	$f_{clk(int)} = \frac{64}{74} \times f_{osc}$	1557 Hz	65 Hz
		010	$f_{clk(int)} = \frac{64}{68} \times f_{osc}$	1694 Hz	70 Hz
		011 ^[2] , 111	$f_{clk(int)} = f_{osc}$	1800 Hz	75 Hz
		100	$f_{clk(int)} = \frac{64}{60} \times f_{osc}$	1920 Hz	80 Hz
		101	$f_{clk(int)} = \frac{64}{56} \times f_{osc}$	2057 Hz	85 Hz
		110	$f_{clk(int)} = \frac{64}{53} \times f_{osc}$	2174 Hz	90 Hz

[1] Calculated with the oscillator frequency of $f_{osc} = 1.800$ Hz. The frame frequency is derived from the internal clock frequency by [Equation 1](#).

[2] Default value.

7.1.6.6 Blinking

The display blinking capabilities of the PCA85132 are very versatile. The whole display can blink at frequencies selected by the blink-select command (see [Table 11](#)). The blink frequencies are derived from the clock frequency (f_{clk}). The ratios between the clock and blink frequencies depend on the blink mode in which the device is operating (see [Table 13](#)).

Table 13. Blink frequencies

Assuming that $f_{clk} = 1.800\text{ kHz}$.

Blink mode	Operating mode ratio	Blink frequency
off	-	blinking off
1	$f_{blink} = \frac{f_{clk}}{768}$	~2.34 Hz
2	$f_{blink} = \frac{f_{clk}}{1536}$	~1.17 Hz
3	$f_{blink} = \frac{f_{clk}}{3072}$	~0.59 Hz

An additional feature is for an arbitrary selection of LCD elements to blink. This applies to the static and 1:2 multiplex drive modes and can be implemented without any communication overheads: With the output bank selector, the displayed RAM banks are exchanged (see [Section 7.5.4 on page 25](#)) with alternate RAM banks at the blink frequency. This mode can also be specified by the blink-select command (see [Table 11 on page 8](#)).

In the 1:3 and 1:4 multiplex modes, where no alternate RAM bank is available, groups of LCD elements can blink selectively by changing the display RAM data at fixed time intervals.

The entire display can blink at a frequency other than the nominal blinking frequency. This can be effectively performed by resetting and setting the display enable bit E at the required rate using the mode-set command (see [Table 6](#)).

7.2 Power-On Reset (POR)

At power-on, the PCA85132 resets to the following starting conditions:

- All backplane and segment outputs are set to V_{LCD}
- The selected drive mode is 1:4 multiplex with $\frac{1}{3}$ bias
- Blinking is switched off
- Input and output bank selectors are reset
- The I²C-bus interface is initialized
- The data pointer and the subaddress counter are cleared (set to logic 0)
- The display is disabled (bit E = 0, see [Table 6 on page 6](#))
- If internal oscillator is selected (pin OSC connected to V_{SS}), then there is no clock signal on pin CLK

Remark: Do not transfer data on the I²C-bus for at least 1 ms after a power-on to allow the reset action to complete.

7.3 Possible display configurations

The display configurations possible with the PCA85132 depend on the required number of active backplane outputs. A selection of display configurations is given in [Table 14](#).

All of the display configurations given in [Table 14](#) can be implemented in a typical system as shown in [Figure 5](#).

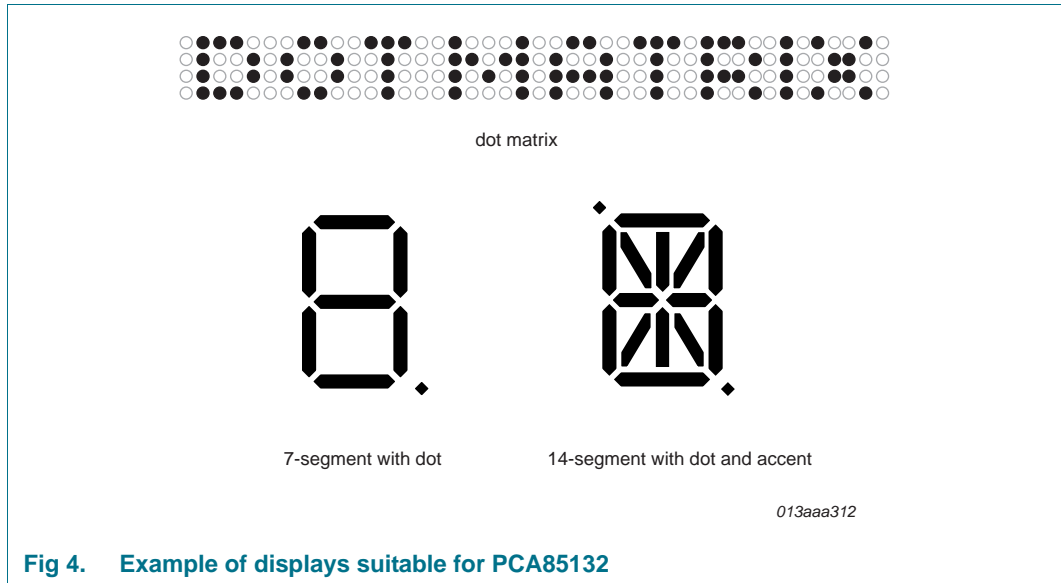

Fig 4. Example of displays suitable for PCA85132

Table 14. Selection of possible display configurations

Number of Backplanes	Icons	Digits/Characters		Dot matrix/ Elements
		7-segment	14-segment	
4	640	80	40	640 dots (4 × 160)
3	480	60	30	480 dots (3 × 160)
2	320	40	20	320 dots (2 × 160)
1	160	20	10	160 dots (1 × 160)

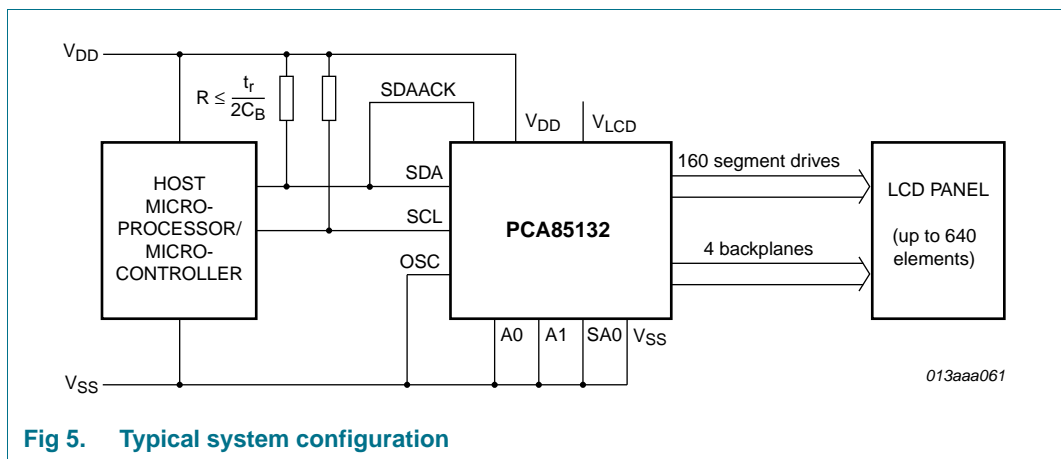

Fig 5. Typical system configuration

The host microcontroller maintains the 2-line I²C-bus communication channel with the PCA85132.

Biasing voltages for the multiplexed LCD waveforms are generated internally, removing the need for an external bias generator. The internal oscillator is selected by connecting pin OSC to V_{SS}. The only other connections required to complete the system are the power supplies (V_{DD}, V_{SS}, and V_{LCD}) and the LCD panel selected for the application.

7.3.1 LCD bias generator

Fractional LCD biasing voltages are obtained from an internal voltage divider of three impedances connected between pins V_{LCD} and V_{SS} . The center impedance is bypassed by switch if the $\frac{1}{2}$ bias voltage level for the 1:2 multiplex drive mode configuration is selected.

7.3.2 Display register

The display register holds the display data while the corresponding multiplex signals are generated.

7.3.3 LCD voltage selector

The LCD voltage selector coordinates the multiplexing of the LCD in accordance with the selected LCD drive configuration. The operation of the voltage selector is controlled by the mode-set command. The biasing configurations that apply to the preferred modes of operation, together with the biasing characteristics as functions of V_{LCD} and the resulting discrimination ratios (D) are given in [Table 15](#).

Discrimination is a term which is defined as the ratio of the on and off RMS voltage across a segment. It can be thought of as a measurement of contrast.

Table 15. Biasing characteristics

LCD drive mode	Number of:		LCD bias configuration	$\frac{V_{off(RMS)}}{V_{LCD}}$	$\frac{V_{on(RMS)}}{V_{LCD}}$	$D = \frac{V_{on(RMS)}}{V_{off(RMS)}}$
	Backplanes	Levels				
static	1	2	static	0	1	∞
1:2 multiplex	2	3	$\frac{1}{2}$	0.354	0.791	2.236
1:2 multiplex	2	4	$\frac{1}{3}$	0.333	0.745	2.236
1:3 multiplex	3	4	$\frac{1}{3}$	0.333	0.638	1.915
1:4 multiplex	4	4	$\frac{1}{3}$	0.333	0.577	1.732

A practical value for V_{LCD} is determined by equating $V_{off(RMS)}$ with a defined LCD threshold voltage ($V_{th(off)}$), typically when the LCD exhibits approximately 10 % contrast. In the static drive mode, a suitable choice is $V_{LCD} > 3V_{th(off)}$.

Multiplex drive modes of 1:3 and 1:4 with $\frac{1}{2}$ bias are possible but the discrimination and hence the contrast ratios are smaller.

Bias is calculated by $\frac{1}{1+a}$, where the values for a are

a = 1 for $\frac{1}{2}$ bias

a = 2 for $\frac{1}{3}$ bias

The RMS on-state voltage ($V_{on(RMS)}$) for the LCD is calculated with [Equation 2](#):

$$V_{on(RMS)} = V_{LCD} \sqrt{\frac{a^2 + 2a + n}{n \times (1 + a)^2}} \tag{2}$$

where the values for n are

n = 1 for static drive mode

n = 2 for 1:2 multiplex drive mode

$n = 3$ for 1:3 multiplex drive mode

$n = 4$ for 1:4 multiplex drive mode

The RMS off-state voltage ($V_{off(RMS)}$) for the LCD is calculated with [Equation 3](#):

$$V_{off(RMS)} = V_{LCD} \sqrt{\frac{a^2 - 2a + n}{n \times (1 + a)^2}} \quad (3)$$

Discrimination is the ratio of $V_{on(RMS)}$ to $V_{off(RMS)}$ and is determined from [Equation 4](#):

$$D = \frac{V_{on(RMS)}}{V_{off(RMS)}} = \sqrt{\frac{a^2 + 2a + n}{a^2 - 2a + n}} \quad (4)$$

Using [Equation 4](#), the discrimination for an LCD drive mode of 1:3 multiplex with

$\frac{1}{2}$ bias is $\sqrt{3} = 1.732$ and the discrimination for an LCD drive mode of 1:4 multiplex with

$\frac{1}{2}$ bias is $\frac{\sqrt{21}}{3} = 1.528$.

The advantage of these LCD drive modes is a reduction of the LCD full scale voltage V_{LCD} as follows:

- 1:3 multiplex ($\frac{1}{2}$ bias): $V_{LCD} = \sqrt{6} \times V_{off(RMS)} = 2.449V_{off(RMS)}$
- 1:4 multiplex ($\frac{1}{2}$ bias): $V_{LCD} = \left[\frac{4 \times \sqrt{3}}{3} \right] = 2.309V_{off(RMS)}$

These compare with $V_{LCD} = 3V_{off(RMS)}$ when $\frac{1}{3}$ bias is used.

V_{LCD} is sometimes referred as the LCD operating voltage.

7.3.3.1 Electro-optical performance

Suitable values for $V_{on(RMS)}$ and $V_{off(RMS)}$ are dependent on the LCD liquid used. The RMS voltages, at which a pixel is switched on or off, determine the transmissibility of the pixel.

For any given liquid, there are two threshold values defined. One point is at 10 % relative transmission (at $V_{th(off)}$) and the other at 90 % relative transmission (at $V_{th(on)}$), see [Figure 6](#). For a good contrast performance, the following rules should be followed:

$$V_{on(RMS)} \geq V_{th(on)} \quad (5)$$

$$V_{off(RMS)} \leq V_{th(off)} \quad (6)$$

$V_{on(RMS)}$ and $V_{off(RMS)}$ are properties of the display driver and are affected by the selection of a (see [Equation 2](#)), n (see [Equation 4](#)), and the V_{LCD} voltage.

$V_{th(off)}$ and $V_{th(on)}$ are properties of the LCD liquid and can be provided by the module manufacturer. $V_{th(off)}$ is sometimes named V_{th} . $V_{th(on)}$ is sometimes named saturation voltage V_{sat} .

It is important to match the module properties to those of the driver in order to achieve optimum performance.

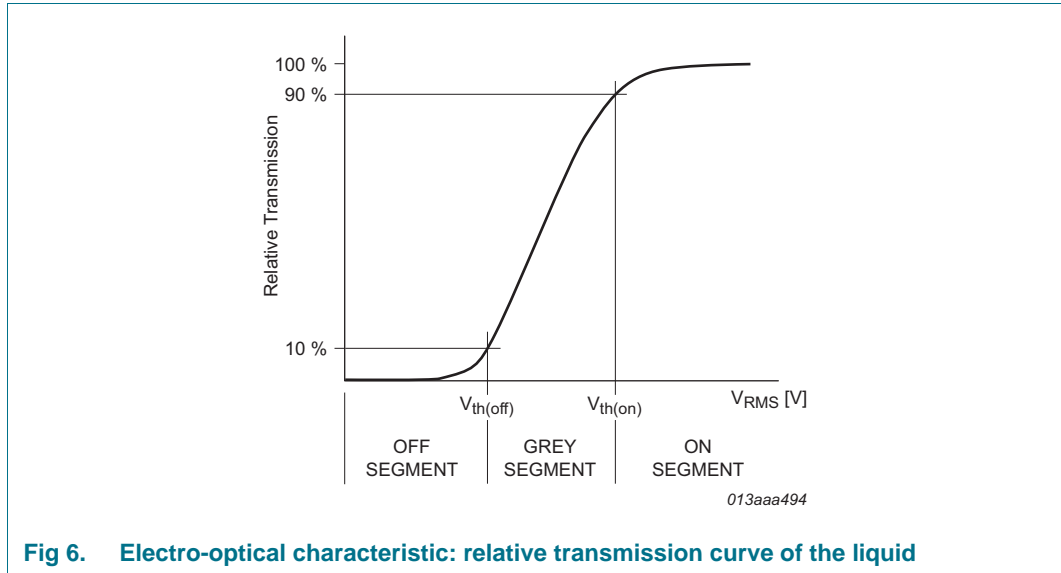

Fig 6. Electro-optical characteristic: relative transmission curve of the liquid

7.3.4 LCD drive mode waveforms

7.3.4.1 Static drive mode

The static LCD drive mode is used when a single backplane is provided in the LCD. Backplane and segment drive waveforms for this mode are shown in [Figure 7](#).

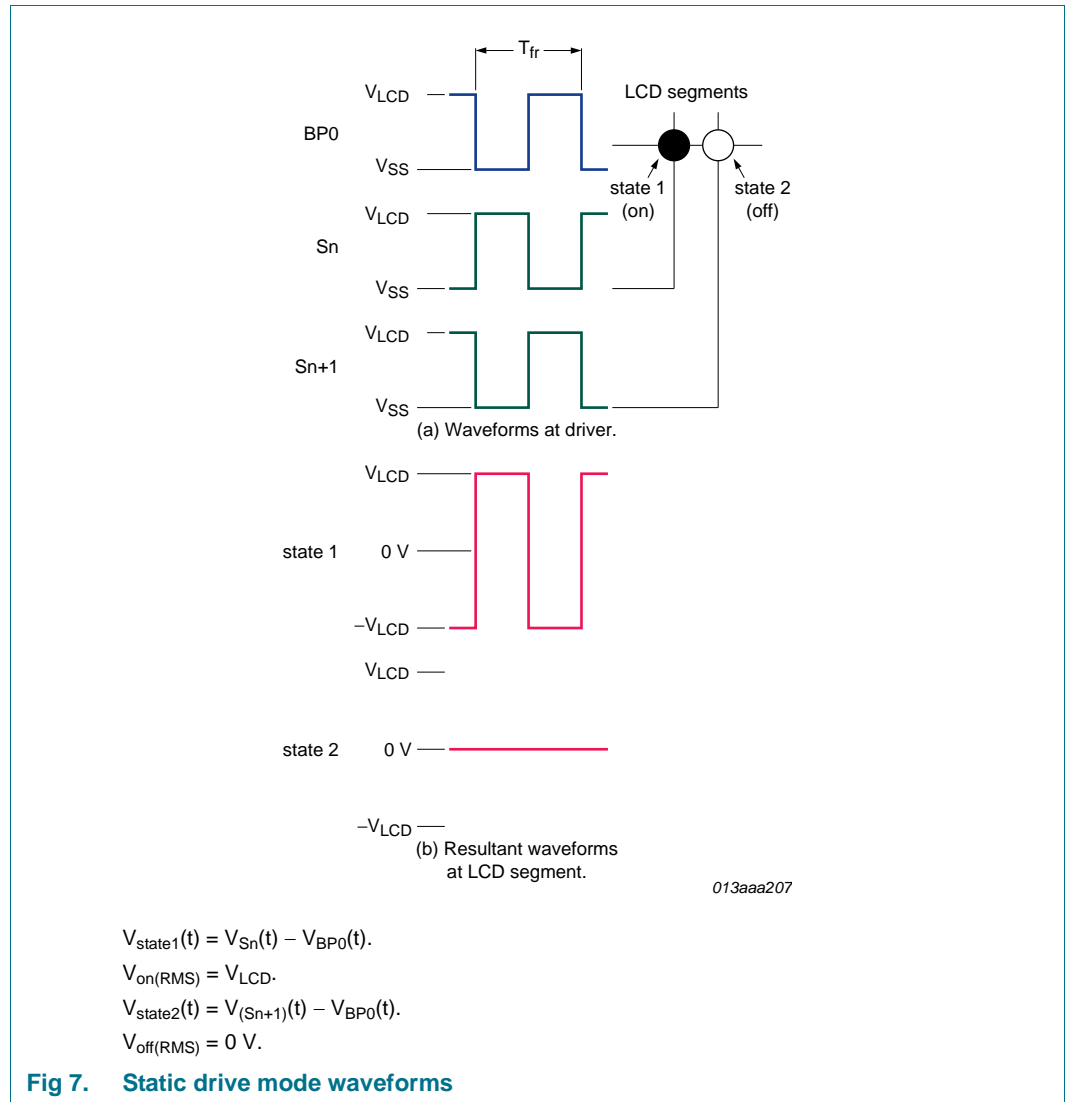

Fig 7. Static drive mode waveforms

7.3.4.2 1:2 multiplex drive mode

When two backplanes are provided in the LCD, the 1:2 multiplex mode applies. The PCA85132 allows the use of 1/2 bias or 1/3 bias in this mode as shown in Figure 8 and Figure 9.

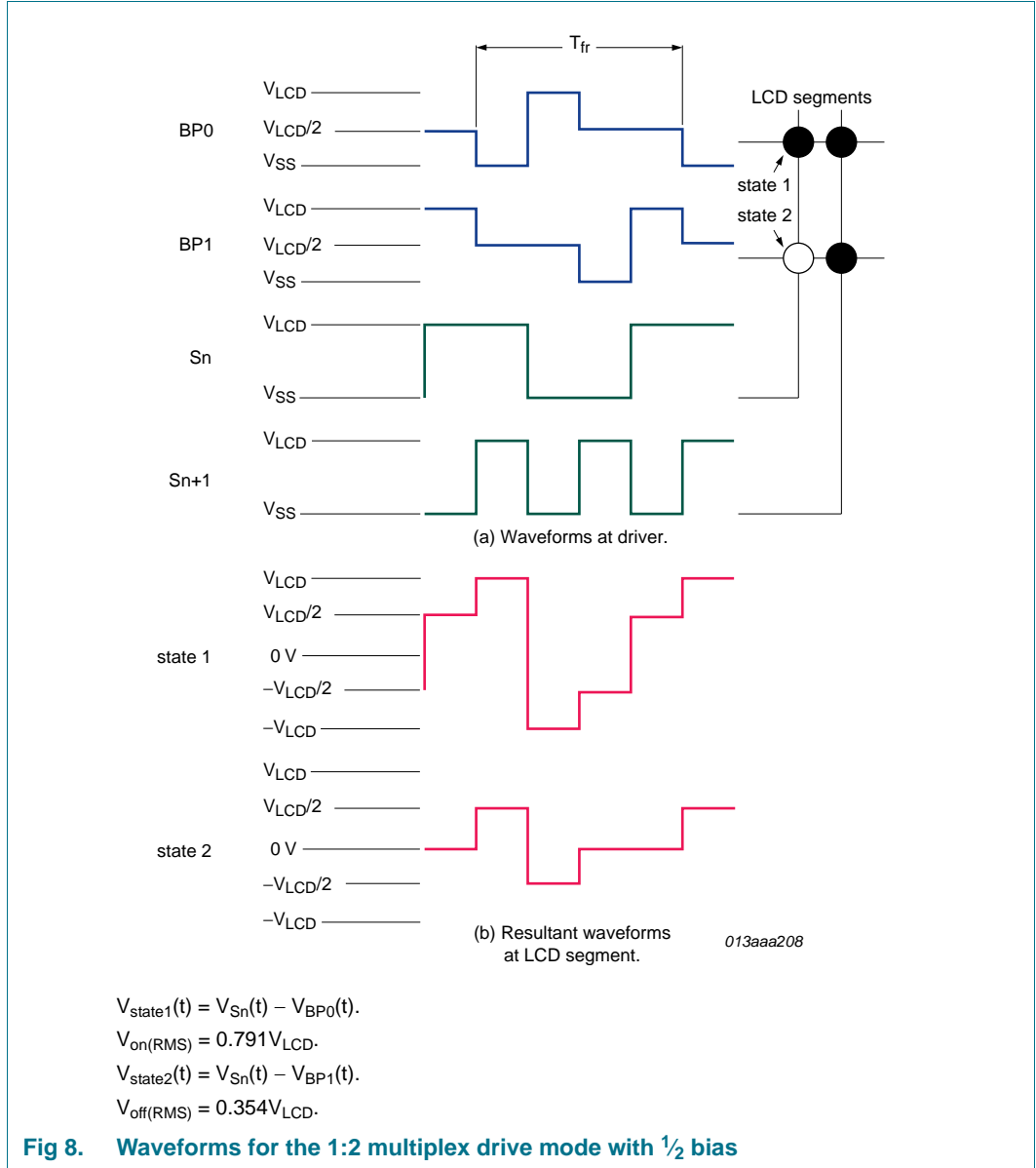

Fig 8. Waveforms for the 1:2 multiplex drive mode with 1/2 bias

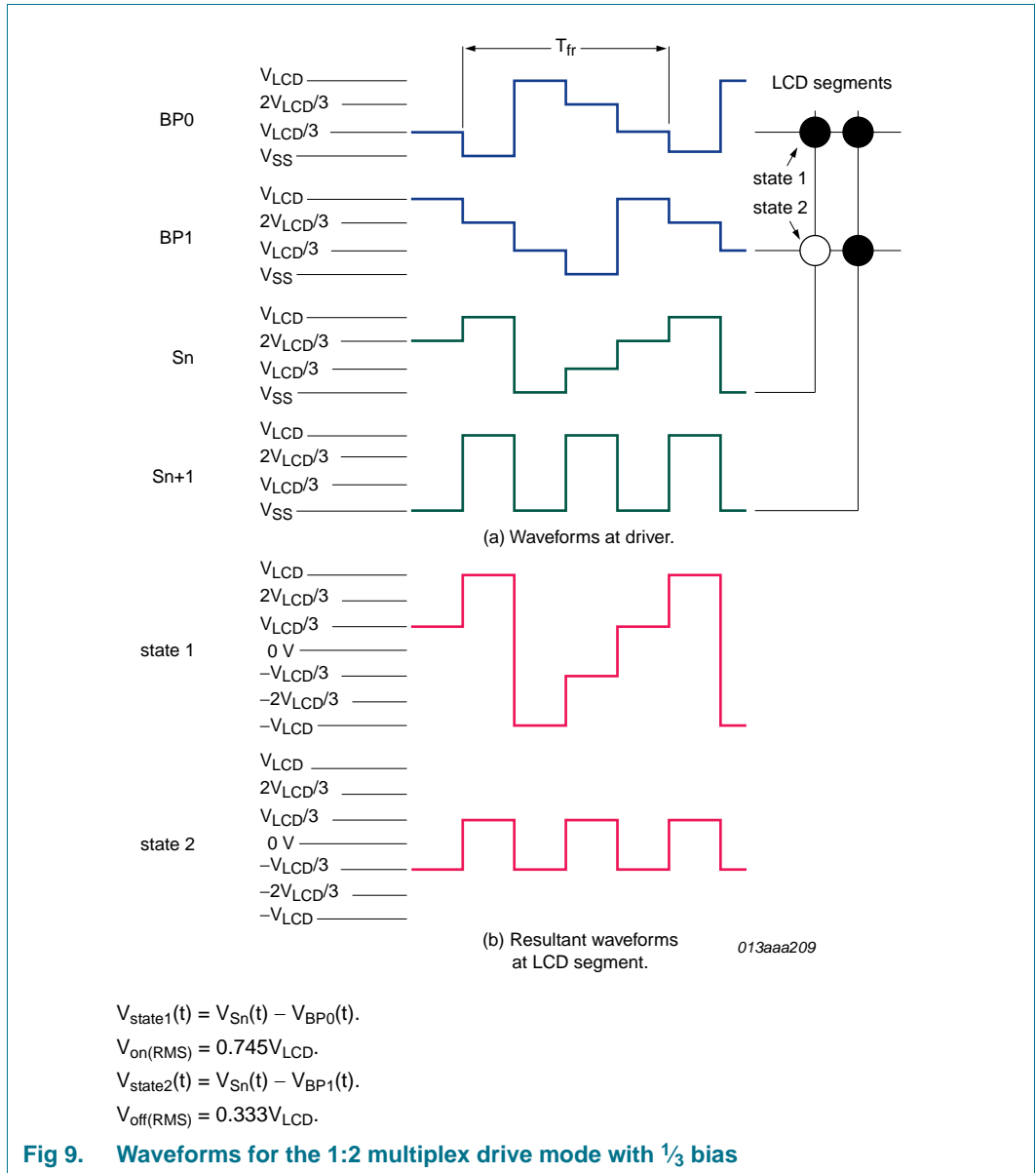
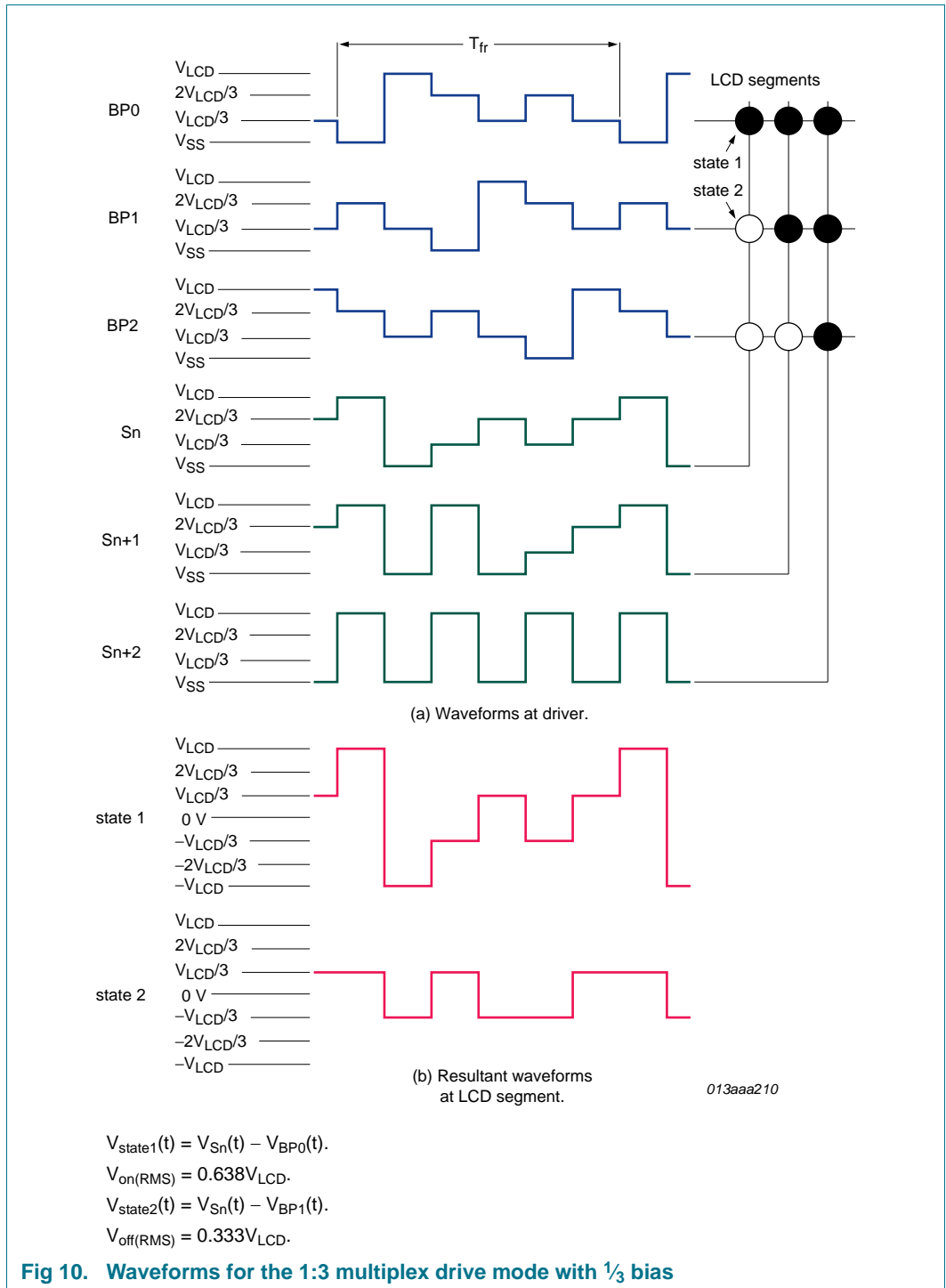

Fig 9. Waveforms for the 1:2 multiplex drive mode with 1/3 bias

7.3.4.3 1:3 multiplex drive mode

When three backplanes are provided in the LCD, the 1:3 multiplex drive mode applies as shown in Figure 10.



7.3.4.4 1:4 multiplex drive mode

When four backplanes are provided in the LCD, the 1:4 multiplex drive mode applies as shown in Figure 11.

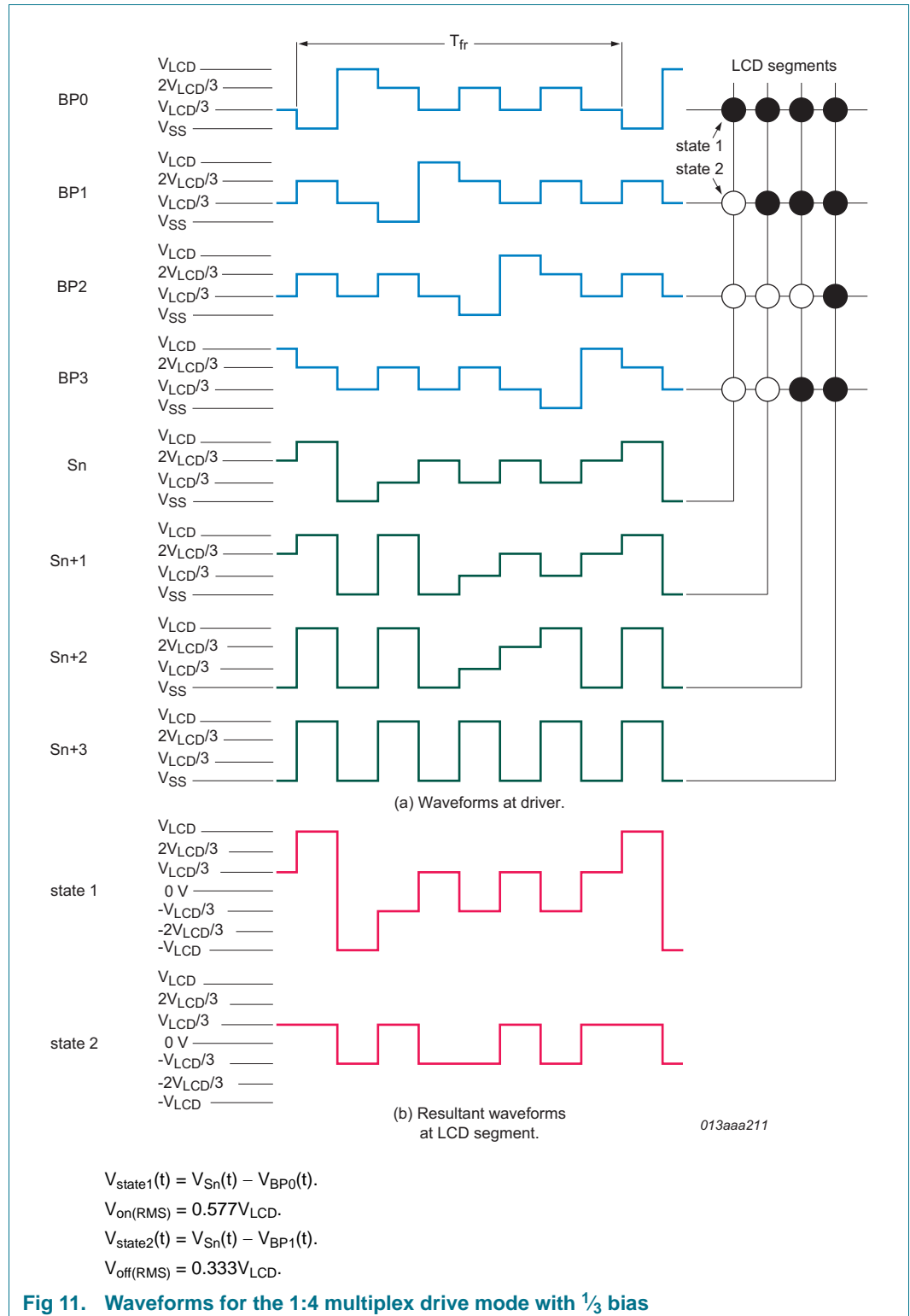

7.4 Backplane and segment outputs

7.4.1 Backplane outputs

The LCD drive section includes four backplane outputs: BP0 to BP3. The backplane output signals are generated in accordance with the selected LCD drive mode.

- In the 1:4 multiplex drive mode BP0 to BP3 must be connected directly to the LCD.

If less than four backplane outputs are required, the unused outputs can be left open-circuit.

- In 1:3 multiplex drive mode BP3 carries the same signal as BP1, therefore these two adjacent outputs can be tied together to give enhanced drive capabilities.
- In 1:2 multiplex drive mode BP0 and BP2, BP1 and BP3 respectively carry the same signals and may also be paired to increase the drive capabilities.
- In static drive mode, the same signal is carried by all four backplane outputs and they can be connected in parallel for very high drive requirements.

The pins for the four backplanes BP0 to BP3 are available on both pin bars of the chip. In applications, it is possible to use either the pins for the backplanes

- on the top pin bar
- on the bottom pin bar
- or both of them to increase the driving strength of the device.

When using all backplanes available they may be connected to the respective sibling (BP0 on the top pin bar with BP0 on the bottom pin bar, and so on).

7.4.2 Segment outputs

The LCD drive section includes 160 segment outputs (S0 to S159) which must be connected directly to the LCD. The segment output signals are generated in accordance with the multiplexed backplane signals and with data resident in the display register. When less than 160 segment outputs are required, the unused segment outputs must be left open-circuit.

7.5 Display RAM

The display RAM is a static 160×4 bit RAM which stores LCD data. There is a one-to-one correspondence between

- the bits in the RAM bitmap and the LCD elements
- the RAM columns and the segment outputs
- the RAM rows and the backplane outputs.

A logic 1 in the RAM bitmap indicates the on-state of the corresponding LCD element; similarly, a logic 0 indicates the off-state.

The display RAM bitmap, [Figure 12](#), shows the rows 0 to 3 which correspond with the backplane outputs BP0 to BP3, and the columns 0 to 159 which correspond with the segment outputs S0 to S159. In multiplexed LCD applications the segment data of the first, second, third, and fourth row of the display RAM are time-multiplexed with BP0, BP1, BP2, and BP3 respectively.

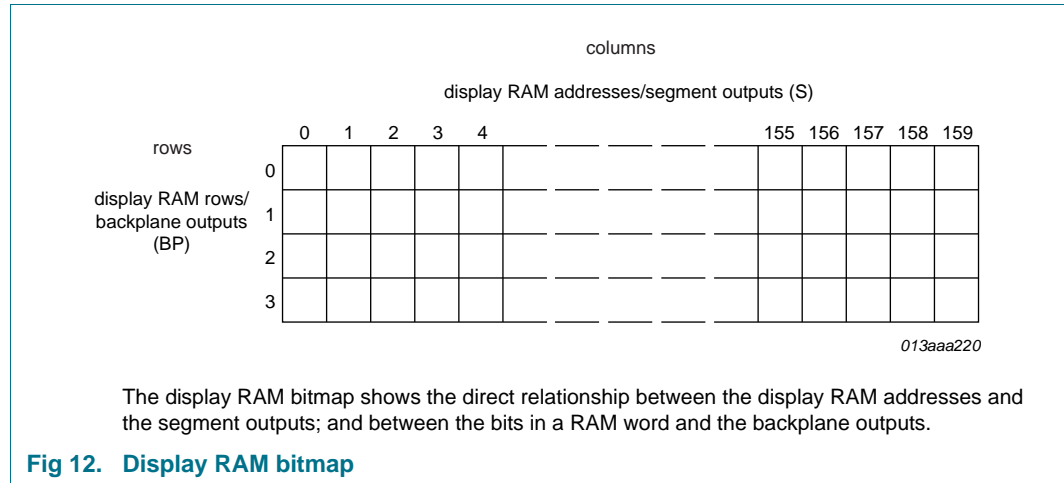

Fig 12. Display RAM bitmap

When display data is transmitted to the PCA85132, the received display bytes are stored in the display RAM in accordance with the selected LCD drive mode. The data is stored as it arrives and does not wait for the acknowledge cycle as with the commands. Depending on the current multiplex drive mode, data is stored singularly, in pairs, triples, or quadruples. To illustrate the filling order, an example of a 7-segment numeric display showing all drive modes is given in [Figure 13](#). The RAM filling organization depicted applies equally to other LCD types.

The following applies to [Figure 13](#):

- In static drive mode the eight transmitted data bits are placed in row 0 as 1 byte.
- In 1:2 multiplex drive mode the eight transmitted data bits are placed in pairs into row 0 and 1 as 2 successive 4-bit RAM words.
- In 1:3 multiplex drive mode the 8 bits are placed in triples into row 0, 1, and 2 as 3 successive 3-bit RAM words, with bit 3 of the third address left unchanged. It is not recommended to use this bit in a display because of the difficult addressing. This last bit may, if necessary, be controlled by an additional transfer to this address but care should be taken to avoid overwriting adjacent data because always full bytes are transmitted (see [Section 7.5.3 on page 25](#)).
- In 1:4 multiplex drive mode, the eight transmitted data bits are placed in quadruples into row 0, 1, 2, and 3 as 2 successive 4-bit RAM words.

drive mode	LCD segments	LCD backplanes	display RAM filling order	transmitted display byte																																																
static			<p>columns display RAM address/segment outputs (s) byte1</p> <table border="1"> <tr><td>n</td><td>n+1</td><td>n+2</td><td>n+3</td><td>n+4</td><td>n+5</td><td>n+6</td><td>n+7</td></tr> <tr><td>c</td><td>b</td><td>a</td><td>f</td><td>g</td><td>e</td><td>d</td><td>DP</td></tr> <tr><td>x</td><td>x</td><td>x</td><td>x</td><td>x</td><td>x</td><td>x</td><td>x</td></tr> <tr><td>x</td><td>x</td><td>x</td><td>x</td><td>x</td><td>x</td><td>x</td><td>x</td></tr> <tr><td>x</td><td>x</td><td>x</td><td>x</td><td>x</td><td>x</td><td>x</td><td>x</td></tr> </table> <p>rows display RAM rows/backplane outputs (BP)</p>	n	n+1	n+2	n+3	n+4	n+5	n+6	n+7	c	b	a	f	g	e	d	DP	x	x	x	x	x	x	x	x	x	x	x	x	x	x	x	x	x	x	x	x	x	x	x	x	<p>MSB</p> <table border="1"> <tr><td>c</td><td>b</td><td>a</td><td>f</td><td>g</td><td>e</td><td>d</td><td>DP</td></tr> </table> <p>LSB</p>	c	b	a	f	g	e	d	DP
n	n+1	n+2	n+3	n+4	n+5	n+6	n+7																																													
c	b	a	f	g	e	d	DP																																													
x	x	x	x	x	x	x	x																																													
x	x	x	x	x	x	x	x																																													
x	x	x	x	x	x	x	x																																													
c	b	a	f	g	e	d	DP																																													
1:2 multiplex			<p>columns display RAM address/segment outputs (s) byte1</p> <table border="1"> <tr><td>n</td><td>n+1</td><td>n+2</td><td>n+3</td></tr> <tr><td>a</td><td>f</td><td>e</td><td>d</td></tr> <tr><td>b</td><td>g</td><td>c</td><td>DP</td></tr> <tr><td>x</td><td>x</td><td>x</td><td>x</td></tr> <tr><td>x</td><td>x</td><td>x</td><td>x</td></tr> </table> <p>rows display RAM rows/backplane outputs (BP)</p>	n	n+1	n+2	n+3	a	f	e	d	b	g	c	DP	x	x	x	x	x	x	x	x	<p>MSB</p> <table border="1"> <tr><td>a</td><td>b</td><td>f</td><td>g</td><td>e</td><td>c</td><td>d</td><td>DP</td></tr> </table> <p>LSB</p>	a	b	f	g	e	c	d	DP																				
n	n+1	n+2	n+3																																																	
a	f	e	d																																																	
b	g	c	DP																																																	
x	x	x	x																																																	
x	x	x	x																																																	
a	b	f	g	e	c	d	DP																																													
1:3 multiplex			<p>columns display RAM address/segment outputs (s) byte1</p> <table border="1"> <tr><td>n</td><td>n+1</td><td>n+2</td></tr> <tr><td>b</td><td>a</td><td>f</td></tr> <tr><td>DP</td><td>d</td><td>e</td></tr> <tr><td>c</td><td>g</td><td>x</td></tr> <tr><td>x</td><td>x</td><td>x</td></tr> </table> <p>rows display RAM rows/backplane outputs (BP)</p>	n	n+1	n+2	b	a	f	DP	d	e	c	g	x	x	x	x	<p>MSB</p> <table border="1"> <tr><td>b</td><td>DP</td><td>c</td><td>a</td><td>d</td><td>g</td><td>f</td><td>e</td></tr> </table> <p>LSB</p>	b	DP	c	a	d	g	f	e																									
n	n+1	n+2																																																		
b	a	f																																																		
DP	d	e																																																		
c	g	x																																																		
x	x	x																																																		
b	DP	c	a	d	g	f	e																																													
1:4 multiplex			<p>columns display RAM address/segment outputs (s) byte1</p> <table border="1"> <tr><td>n</td><td>n+1</td></tr> <tr><td>a</td><td>f</td></tr> <tr><td>c</td><td>e</td></tr> <tr><td>b</td><td>g</td></tr> <tr><td>DP</td><td>d</td></tr> </table> <p>rows display RAM rows/backplane outputs (BP)</p>	n	n+1	a	f	c	e	b	g	DP	d	<p>MSB</p> <table border="1"> <tr><td>a</td><td>c</td><td>b</td><td>DP</td><td>f</td><td>e</td><td>g</td><td>d</td></tr> </table> <p>LSB</p>	a	c	b	DP	f	e	g	d																														
n	n+1																																																			
a	f																																																			
c	e																																																			
b	g																																																			
DP	d																																																			
a	c	b	DP	f	e	g	d																																													

001aa1646

x = data bit unchanged

Fig 13. Relationships between LCD layout, drive mode, display RAM filling order, and display data transmitted over the I²C-bus

7.5.1 Data pointer

The addressing mechanism for the display RAM is realized using the data pointer. This allows the loading of an individual display data byte, or a series of display data bytes, into any location of the display RAM. The sequence commences with the initialization of the data pointer by the load-data-pointer command (see [Table 7 on page 7](#) and [Table 8 on page 7](#)). Following this command, an arriving data byte is stored at the display RAM address indicated by the data pointer. The filling order is shown in [Figure 13](#).

After each byte is stored, the content of the data pointer is automatically incremented by a value dependent on the selected LCD drive mode:

- In static drive mode by eight
- In 1:2 multiplex drive mode by four
- In 1:3 multiplex drive mode by three
- In 1:4 multiplex drive mode by two

If an I²C-bus data access is terminated early, then the state of the data pointer is unknown. The data pointer should be re-written before further RAM accesses.

7.5.2 Subaddress counter

The storage of display data is conditioned by the content of the subaddress counter. Storage is allowed only when the content of the subaddress counter matches with the hardware subaddress applied to A0 and A1. The subaddress counter value is defined by the device-select command (see [Table 9 on page 7](#)). If the content of the subaddress counter and the hardware subaddress do not match then data storage is inhibited but the data pointer is incremented as if data storage had taken place. The subaddress counter is also incremented when the data pointer overflows.

The storage arrangements described lead to extremely efficient data loading in cascaded applications. When a series of display bytes are sent to the display RAM, automatic wrap-over to the next PCA85132 occurs when the last RAM address is exceeded. Subaddressing across device boundaries is successful even if the change to the next device in the cascade occurs within a transmitted character.

The hardware subaddress must not be changed while the device is being accessed on the I²C-bus interface.

7.5.3 RAM writing in 1:3 multiplex drive mode

In 1:3 multiplex drive mode, the RAM is written as shown in [Table 16](#) (see [Figure 13](#) as well).

Table 16. Standard RAM filling in 1:3 multiplex drive mode

Assumption: BP2/S2, BP2/S5, BP2/S8 etc. **are not connected** to any elements on the display.

Display RAM bits (rows)/backplane outputs (BPn)	Display RAM addresses (columns)/segment outputs (Sn)										
	0	1	2	3	4	5	6	7	8	9	:
0	a7	a4	a1	b7	b4	b1	c7	c4	c1	d7	:
1	a6	a3	a0	b6	b3	b0	c6	c3	c0	d6	:
2	a5	a2	-	b5	b2	-	c5	c2	-	d5	:
3	-	-	-	-	-	-	-	-	-	-	:

If the bit at position BP2/S2 would be written by a second byte transmitted, then the mapping of the segment bits would change as illustrated in [Table 17](#).

Table 17. Entire RAM filling by rewriting in 1:3 multiplex drive mode

Assumption: BP2/S2, BP2/S5, BP2/S8 etc. **are connected** to elements on the display.

Display RAM bits (rows)/backplane outputs (BPn)	Display RAM addresses (columns)/segment outputs (Sn)										
	0	1	2	3	4	5	6	7	8	9	:
0	a7	a4	a1/b7	b4	b1/c7	c4	c1/d7	d4	d1/e7	e4	:
1	a6	a3	a0/b6	b3	b0/c6	c3	c0/d6	d3	d0/e6	e3	:
2	a5	a2	b5	b2	c5	c2	d5	d2	e5	e2	:
3	-	-	-	-	-	-	-	-	-	-	:

In the case described in [Table 17](#) the RAM has to be written entirely and BP2/S2, BP2/S5, BP2/S8, and so on, have to be connected to elements on the display. This can be achieved by a combination of writing and rewriting the RAM like follows:

- In the first write to the RAM, bits a7 to a0 are written
- The data-pointer (see [Section 7.1.2 on page 7](#)) has to be set to the address of bit a1
- In the second write, bits b7 to b0 are written, overwriting bits a1 and a0 with bits b7 and b6
- The data-pointer has to be set to the address of bit b1
- In the third write, bits c7 to c0 are written, overwriting bits b1 and b0 with bits c7 and c6

Depending on the method of writing to the RAM (standard or entire filling by rewriting), some elements remain unused or can be used, but it has to be considered in the module layout process as well as in the driver software design.

7.5.4 Bank selection

7.5.4.1 Output bank selector

The output bank selector (see [Table 10 on page 8](#)) selects one of the four rows per display RAM address for transfer to the display register. The actual row selected depends on the particular LCD drive mode in operation and on the instant in the multiplex sequence.

- In 1:4 multiplex mode, all RAM addresses of row 0 are selected, followed by the contents of row 1, row 2, and then row 3
- In 1:3 multiplex mode, rows 0, 1, and 2 are selected sequentially
- In 1:2 multiplex mode, rows 0 and 1 are selected
- In static mode, row 0 is selected

7.5.4.2 Input bank selector

The input bank selector loads display data into the display RAM in accordance with the selected LCD drive configuration. Display data can be loaded by using the bank-select command (see Table 10). The input bank selector functions independently to the output bank selector.

7.5.4.3 RAM bank switching

The PCA85132 includes a RAM bank switching feature in the static and 1:2 multiplex drive modes. A bank can be thought of as one RAM row or a collection of RAM rows (see Figure 14). The RAM bank switching gives the provision for preparing display information in an alternative bank and to be able to switch to it once it is complete.

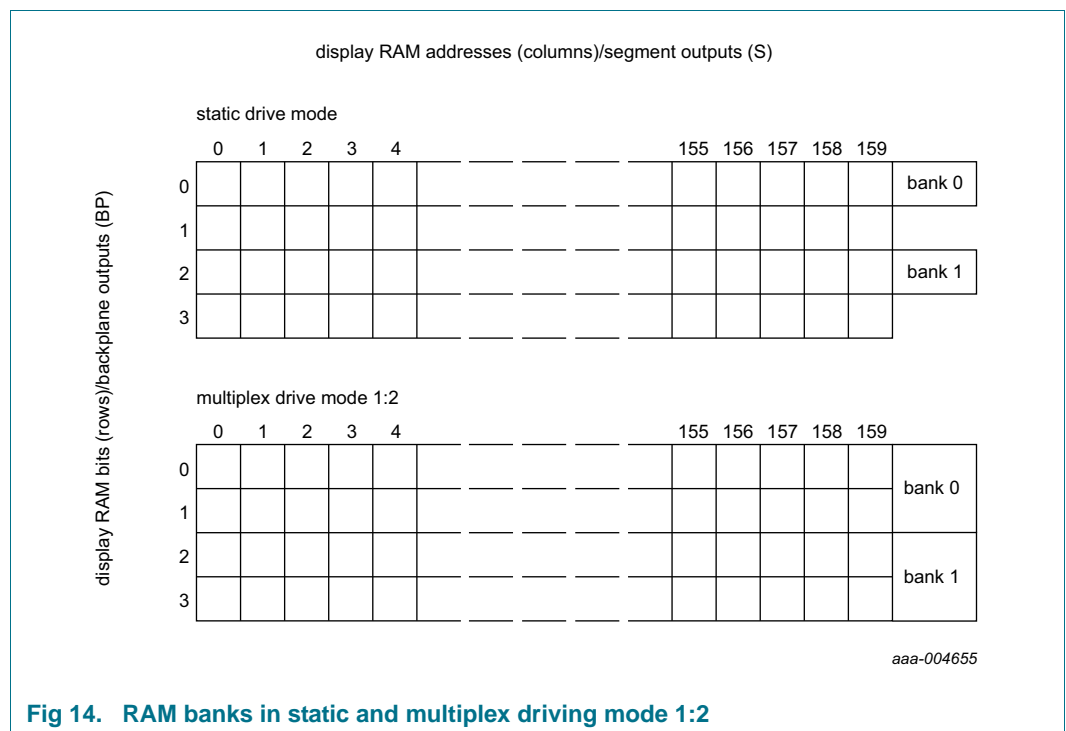

Fig 14. RAM banks in static and multiplex driving mode 1:2

There are two banks; bank 0 and bank 1. Figure 14 shows the location of these banks relative to the RAM map. Input and output banks can be set independently from one another with the Bank-select command (see Table 10 on page 8). Figure 15 shows the concept.

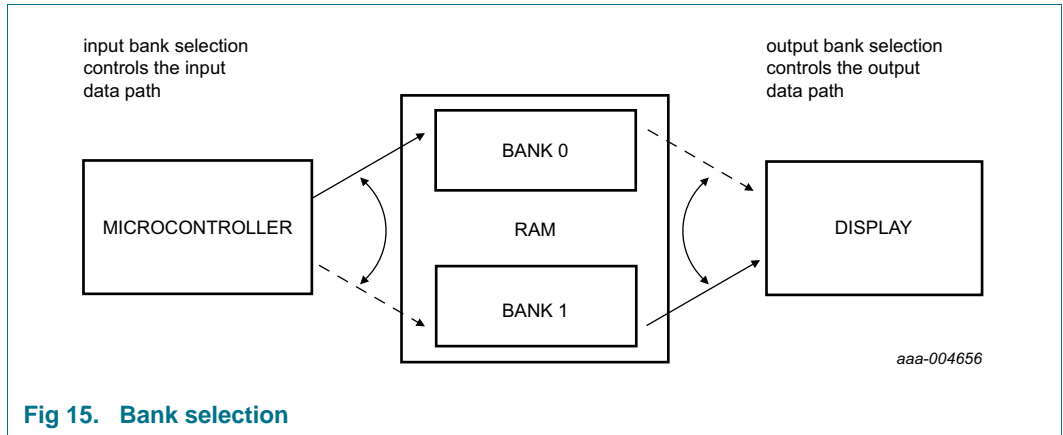

Fig 15. Bank selection

In the static drive mode, the bank-select command may request the contents of row 2 to be selected for display instead of the contents of row 0. In the 1:2 multiplex mode, the contents of rows 2 and 3 may be selected instead of rows 0 and 1. This gives the provision for preparing display information in an alternative bank and to be able to switch to it once it is assembled.

In [Figure 16](#) an example is shown for 1:2 multiplex drive mode where the displayed data is read from the first two rows of the memory (bank 0), while the transmitted data is stored in the second two rows of the memory (bank 1).

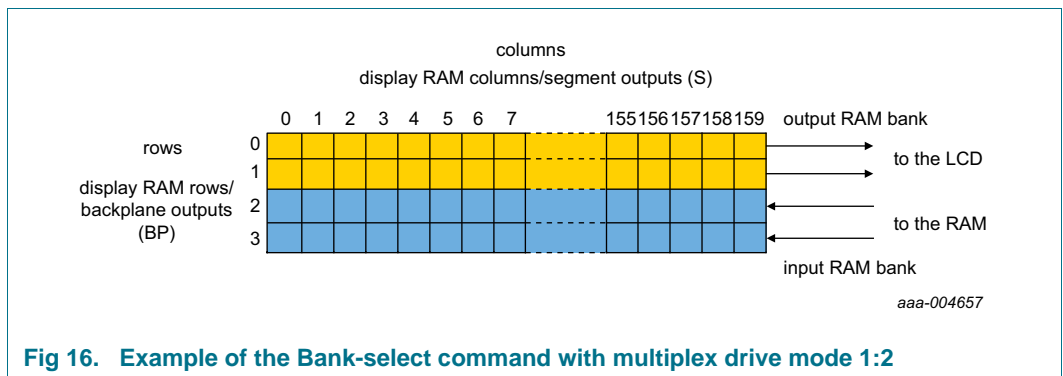

Fig 16. Example of the Bank-select command with multiplex drive mode 1:2

8. Characteristics of the I²C-bus

The I²C-bus is for bidirectional, two-line communication between different ICs or modules. The two lines are a Serial DAta line (SDA) and a Serial CLock line (SCL). Both lines must be connected to a positive supply via a pull-up resistor when connected to the output stages of a device. Data transfer may be initiated only when the bus is not busy.

By connecting pin SDAACK to pin SDA on the PCA85132, the SDA line becomes fully I²C-bus compatible. In COG applications where the track resistance from the SDAACK pin to the system SDA line can be significant, possibly a voltage divider is generated by the bus pull-up resistor and the Indium Tin Oxide (ITO) track resistance. As a consequence, it may be possible that the acknowledge generated by the PCA85132 cannot be interpreted as logic 0 by the master. In COG applications where the acknowledge cycle is required, it is therefore necessary to minimize the track resistance from the SDAACK pin to the system SDA line to guarantee a valid LOW level (see [Section 14.2 on page 42](#)).

By separating the acknowledge output from the serial data line (having the SDAACK open circuit) design efforts to generate a valid acknowledge level can be avoided. However, in that case the I²C-bus master has to be set up in such a way that it ignores the acknowledge cycle.²

The following definition assumes that SDA and SDAACK are connected and refers to the pair as SDA.

8.1 Bit transfer

One data bit is transferred during each clock pulse. The data on the SDA line must remain stable during the HIGH period of the clock pulse as changes in the data line at this time are interpreted as a control signal (see [Figure 17](#)).

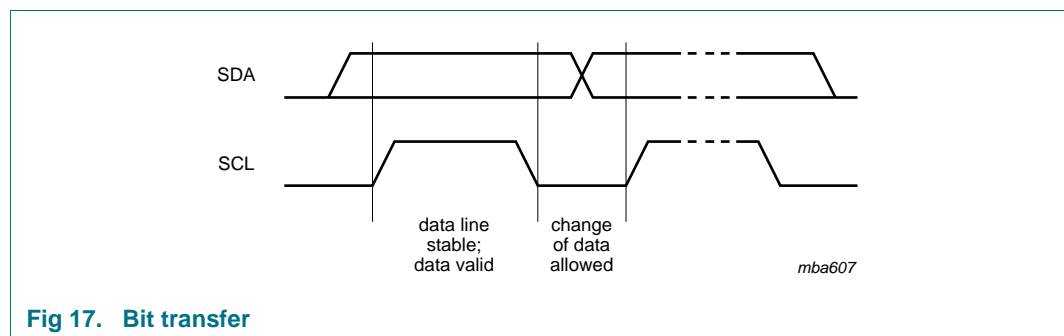

Fig 17. Bit transfer

8.1.1 START and STOP conditions

Both data and clock lines remain HIGH when the bus is not busy. A HIGH-to-LOW change of the data line, while the clock is HIGH is defined as the START condition (S).

A LOW-to-HIGH change of the data line while the clock is HIGH is defined as the STOP condition (P). The START and STOP conditions are shown in [Figure 18](#).

2. For further information, please consider the NXP application note: [Ref. 1 "AN10170"](#).

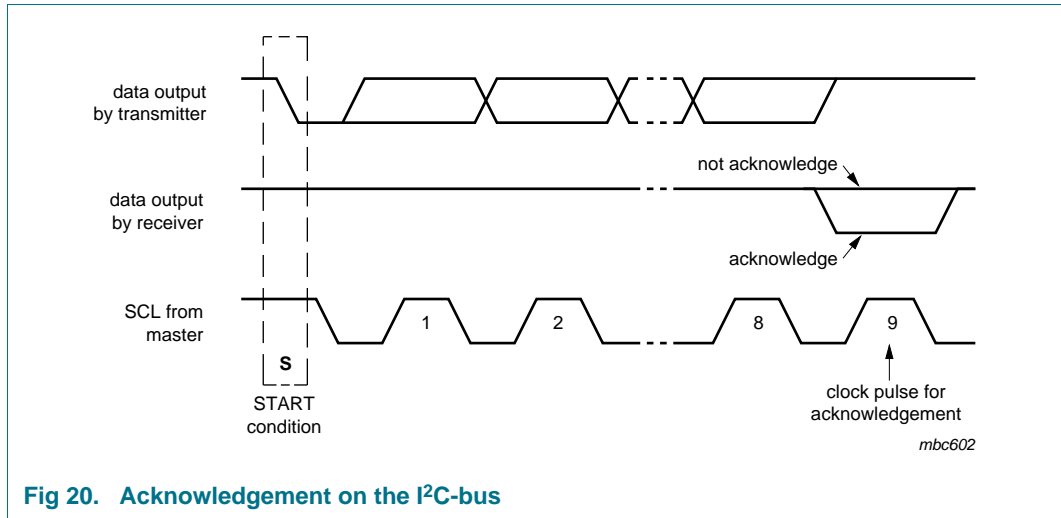

Fig 20. Acknowledgement on the I²C-bus

8.4 I²C-bus controller

The PCA85132 acts as an I²C-bus slave receiver. It does not initiate I²C-bus transfers or transmit data to an I²C-bus master receiver. The only data output from the PCA85132 is the acknowledge signal. Device selection depends on the I²C-bus slave address, on the transferred command data, and on the hardware subaddress.

In single device applications, the hardware subaddress inputs A0 and A1 are normally tied to V_{SS} which defines the hardware subaddress 0. In multiple device applications A0 and A1 are tied to V_{SS} or V_{DD} in accordance with a binary coding scheme. No two devices with a common I²C-bus slave address must have the same hardware subaddress.

8.5 Input filters

To enhance noise immunity in electrical adverse environments, RC low-pass filters are provided on the SDA and SCL lines.

8.6 I²C-bus protocol

Two I²C-bus slave addresses (0111 000 and 0111 001) are reserved for the PCA85132. The entire I²C-bus slave address byte is shown in [Table 18](#).

Table 18. I²C slave address byte

Bit	Slave address							0 LSB
	7 MSB	6	5	4	3	2	1	
	0	1	1	1	0	0	SA0	R/W

The PCA85132 is a write-only device and does not respond to a read access, therefore bit 0 should always be logic 0. Bit 1 of the slave address byte, that a PCA85132 responds to, is defined by the level tied to its SA0 input (V_{SS} for logic 0 and V_{DD} for logic 1).

Having two reserved slave addresses allows the following on the same I²C-bus:

- Up to 8 PCA85132 on the same I²C-bus for very large LCD applications
- The use of two types of LCD multiplex drive modes on the same I²C-bus

The I²C-bus protocol is shown in [Figure 21](#). The sequence is initiated with a START condition (S) from the I²C-bus master which is followed by one of two possible PCA85132 slave addresses available. All PCA85132 with the corresponding SA0 level acknowledge in parallel to the slave address, but all PCA85132 with the alternative SA0 level ignore the whole I²C-bus transfer.

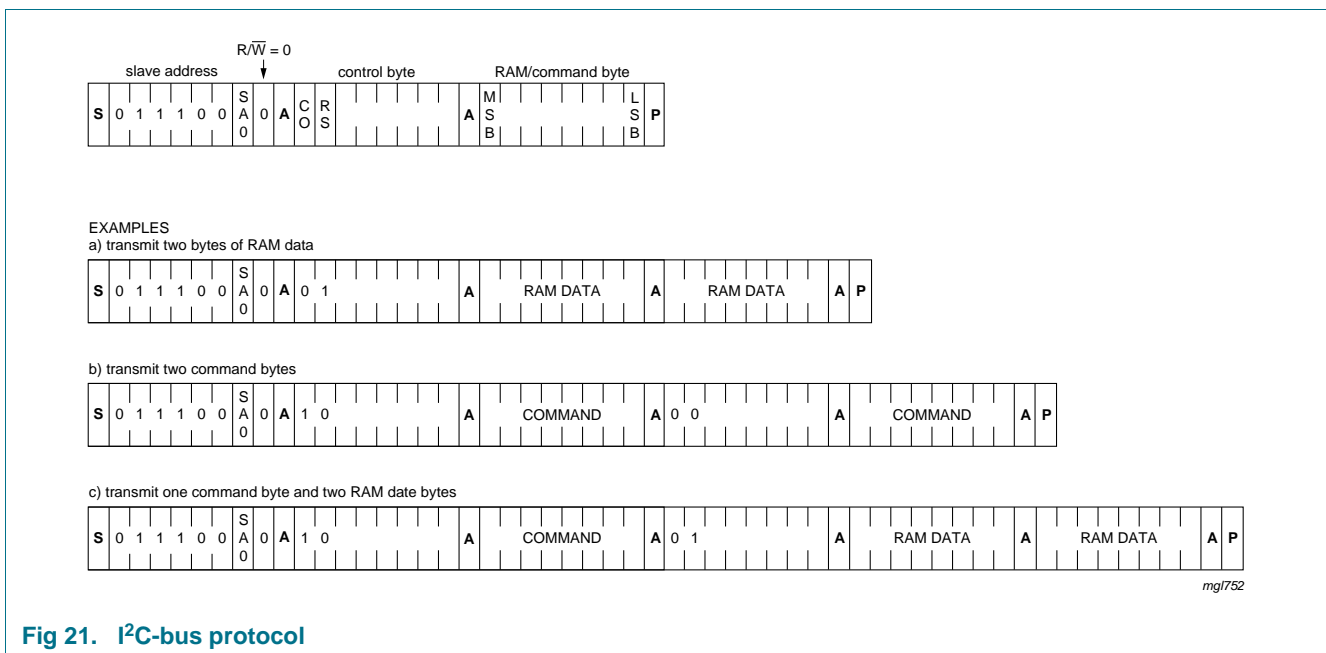
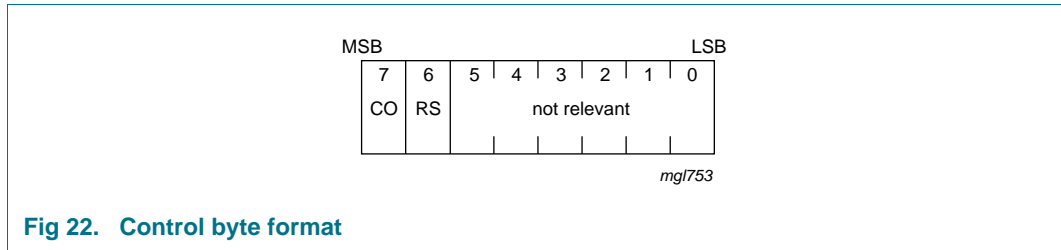

Fig 21. I²C-bus protocol

After acknowledgement, a control byte follows which defines if the next byte is RAM or command information.

Table 19. Control byte description

Bit	Symbol	Value	Description
7	CO		continue bit
		0	last control byte
		1	control bytes continue
6	RS		register selection
		0	command register
		1	data register
5 to 0	-	-	not relevant



In this way, it is possible to configure the device and then fill the display RAM with little overhead.

The command bytes and control bytes are also acknowledged by all addressed PCA85132 connected to the bus.

The display bytes are stored in the display RAM at the address specified by the data pointer and the subaddress counter; see [Section 7.5.1](#) and [Section 7.5.2](#).

The acknowledgement after each byte is made only by the (A0 and A1) addressed PCA85132. After the last (display) byte, the I²C-bus master issues a STOP condition (P). Alternatively a repeated START may be asserted to restart an I²C-bus access.

9. Internal circuitry

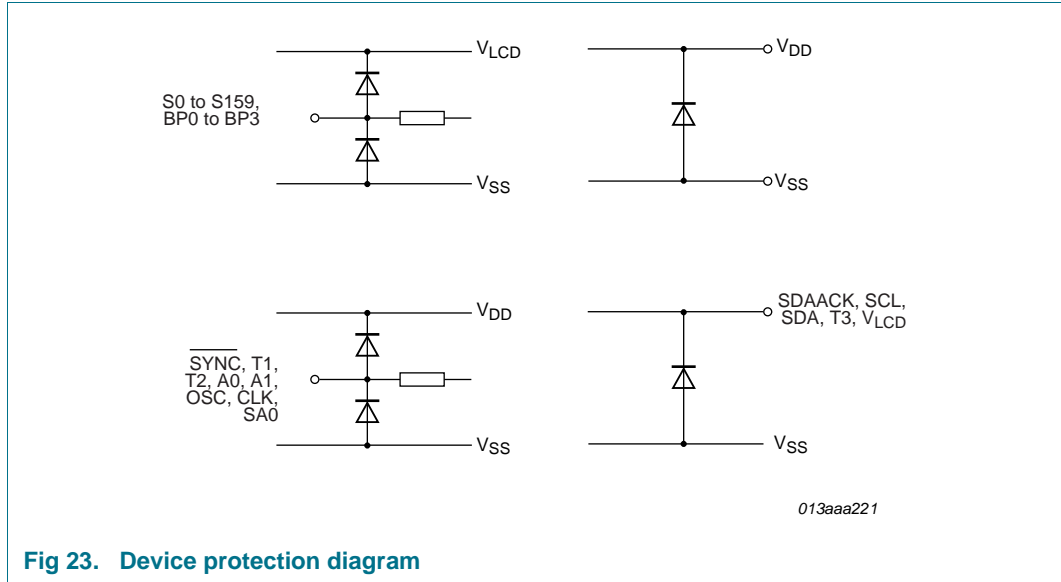

Fig 23. Device protection diagram

10. Safety notes

CAUTION



This device is sensitive to ElectroStatic Discharge (ESD). Observe precautions for handling electrostatic sensitive devices. Such precautions are described in the *ANSI/ESD S20.20*, *IEC/ST 61340-5*, *JESD625-A* or equivalent standards.

CAUTION



Static voltages across the liquid crystal display can build up when the LCD supply voltage (V_{LCD}) is on while the IC supply voltage (V_{DD}) is off, or vice versa. This may cause unwanted display artifacts. To avoid such artifacts, V_{LCD} and V_{DD} must be applied or removed together.

CAUTION



Semiconductors are light sensitive. Exposure to light sources can cause the IC to malfunction. The IC must be protected against light. The protection must be applied to all sides of the IC.

11. Limiting values

Table 20. Limiting values

In accordance with the Absolute Maximum Rating System (IEC 60134).^[1]

Symbol	Parameter	Conditions	Min	Max	Unit
V _{DD}	supply voltage		-0.5	+6.5	V
I _{DD}	supply current		-50	+50	mA
V _{LCD}	LCD supply voltage		-0.5	+9.0	V
I _{DD(LCD)}	LCD supply current		-50	+50	mA
V _i	input voltage	on pins CLK, SYNC, SA0, OSC, SDA, SCL, A0, A1, T1, T2, and T3	-0.5	+6.5	V
I _I	input current		-10	+10	mA
V _O	output voltage	on pins S0 to S159 and BP0 to BP3	-0.5	+9.0	V
		on pins SDAACK, CLK, SYNC	-0.5	+6.5	V
I _O	output current		-10	+10	mA
I _{SS}	ground supply current		-50	+50	mA
P _{tot}	total power dissipation		-	400	mW
P/out	power dissipation per output		-	100	mW
V _{ESD}	electrostatic discharge voltage	HBM	[2] -	±4500	V
		MM	[3] -	±300	V
I _{lu}	latch-up current		[4] -	200	mA
T _{stg}	storage temperature		[5] -65	+150	°C
T _{amb}	ambient temperature	operating device	-40	+95	°C

[1] Stresses above these values listed may cause permanent damage to the device.

[2] Pass level; Human Body Model (HBM) according to Ref. 6 "JESD22-A114".

[3] Pass level; Machine Model (MM), according to Ref. 7 "JESD22-A115".

[4] Pass level; latch-up testing, according to Ref. 8 "JESD78" at maximum ambient temperature (T_{amb(max)}).

[5] According to the store and transport requirements (see Ref. 11 "UM10569") the devices have to be stored at a temperature of +8 °C to +45 °C and a humidity of 25 % to 75 %.

12. Static characteristics

Table 21. Static characteristics
 $V_{DD} = 1.8 \text{ V to } 5.5 \text{ V}; V_{SS} = 0 \text{ V}; V_{LCD} = 1.8 \text{ V to } 8.0 \text{ V}; T_{amb} = -40 \text{ }^{\circ}\text{C to } +95 \text{ }^{\circ}\text{C};$ unless otherwise specified.

Symbol	Parameter	Conditions	Min	Typ	Max	Unit
Supplies						
V_{DD}	supply voltage		1.8	-	5.5	V
V_{LCD}	LCD supply voltage		1.8	-	8.0	V
I_{DD}	supply current	$f_{clk(ext)} = 1.800 \text{ kHz}$	[1][2][3]	-	20	μA
		with internal oscillator running	[1][3]	-	60	μA
$I_{DD(LCD)}$	LCD supply current	$f_{clk(ext)} = 1.800 \text{ kHz}$	[1][2][4]	-	70	μA
		with internal oscillator running	[1][4]	-	70	μA
Logic⁵⁾						
V_I	input voltage	on pins SDA and SCL	-0.5	-	+5.5	V
		all other input pins	-0.5	-	$V_{DD} + 0.5$	V
V_{IH}	HIGH-level input voltage	on pins CLK, $\overline{\text{SYNC}}$, OSC, A0, A1, SA0, SCL, and SDA	$0.7V_{DD}$	-	-	V
V_{IL}	LOW-level input voltage	on pins CLK, $\overline{\text{SYNC}}$, OSC, A0, A1, SA0, SCL, and SDA	-	-	$0.3V_{DD}$	V
V_O	output voltage	on pins CLK and $\overline{\text{SYNC}}$	-0.5	-	$V_{DD} + 0.5$	V
		on pin SDAACK	-0.5	-	+5.5	V
V_{OH}	HIGH-level output voltage	on pin $\overline{\text{SYNC}}$, CLK	$0.8V_{DD}$	-	V_{DD}	V
V_{OL}	LOW-level output voltage	on pin $\overline{\text{SYNC}}$, CLK, SDAACK	V_{SS}	-	$0.2V_{DD}$	V
I_{OH}	HIGH-level output current	output source current; $V_{OH} = 4.6 \text{ V};$ $V_{DD} = 5 \text{ V};$ on pin CLK	1.5	-	-	mA
I_{OL}	LOW-level output current	output sink current; on pins CLK and $\overline{\text{SYNC}}$				
		$V_{OL} = 0.4 \text{ V};$ $V_{DD} = 5 \text{ V}$	1.5	-	-	mA
		on pin SDAACK				
		$V_{DD} \leq 2 \text{ V};$ $V_{OL} = 0.2V_{DD}$	3	-	-	mA
		$2 \text{ V} < V_{DD} < 3 \text{ V};$ $V_{OL} = 0.4 \text{ V}$	3	-	-	mA
	$V_{DD} \geq 3 \text{ V};$ $V_{OL} = 0.4 \text{ V}$	6	-	-	mA	
V_{POR}	power-on reset voltage		1.0	1.3	1.6	V
I_L	leakage current	$V_I = V_{DD}$ or $V_{SS};$ on pin OSC, CLK, A0, A1, SA0, SDA, and SCL	-1	-	+1	μA

Table 21. Static characteristics ...continued

$V_{DD} = 1.8\text{ V to }5.5\text{ V}$; $V_{SS} = 0\text{ V}$; $V_{LCD} = 1.8\text{ V to }8.0\text{ V}$; $T_{amb} = -40\text{ }^{\circ}\text{C to }+95\text{ }^{\circ}\text{C}$; unless otherwise specified.

Symbol	Parameter	Conditions	Min	Typ	Max	Unit
LCD outputs						
ΔV_O	output voltage variation	on pins BP0 to BP3 and S0 to S159	[6][7] -30	-	+30	mV
R_O	output resistance	$V_{LCD} = 5\text{ V}$				
		on pins BP0 to BP3	-	1.5	5	k Ω
		on pins S0 to S159	-	2.0	5	k Ω

- [1] LCD outputs are open-circuit; inputs at V_{SS} or V_{DD} ; I²C-bus inactive; $V_{LCD} = 8.0\text{ V}$, $V_{DD} = 5.0\text{ V}$ and RAM written with all logic 1.
- [2] External clock with 50 % duty factor.
- [3] For typical values, see [Figure 24](#).
- [4] For typical values, see [Figure 25](#).
- [5] The I²C-bus interface of PCA85132 is 5 V tolerant.
- [6] Variation between any 2 backplanes on a given voltage level; static measured.
- [7] Variation between any 2 segments on a given voltage level; static measured.

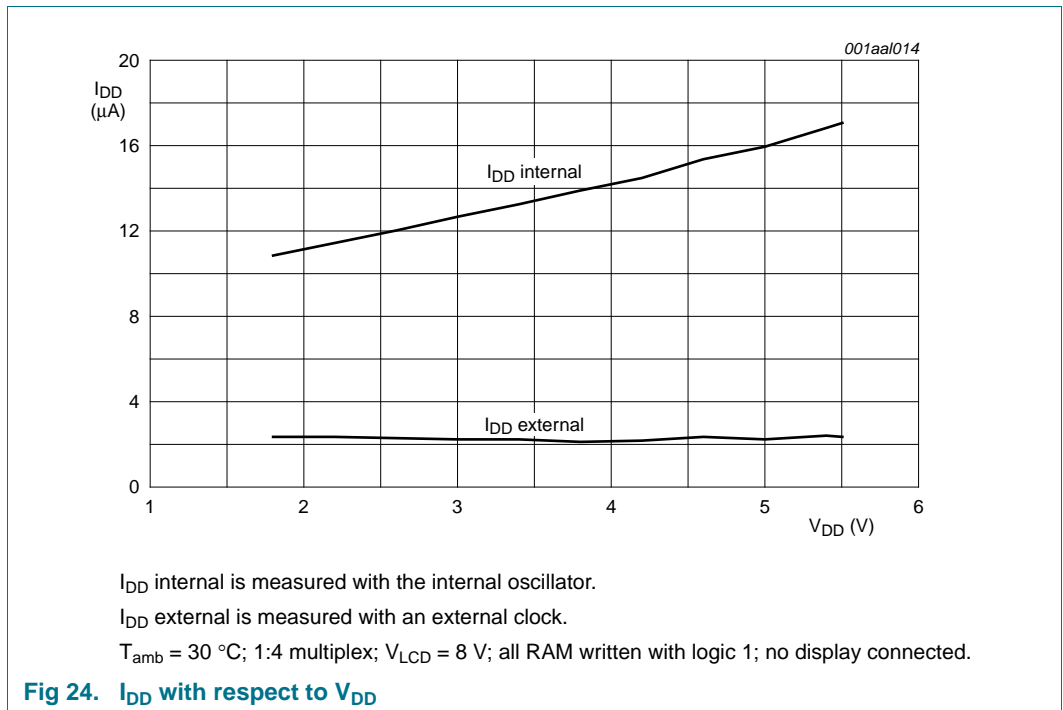

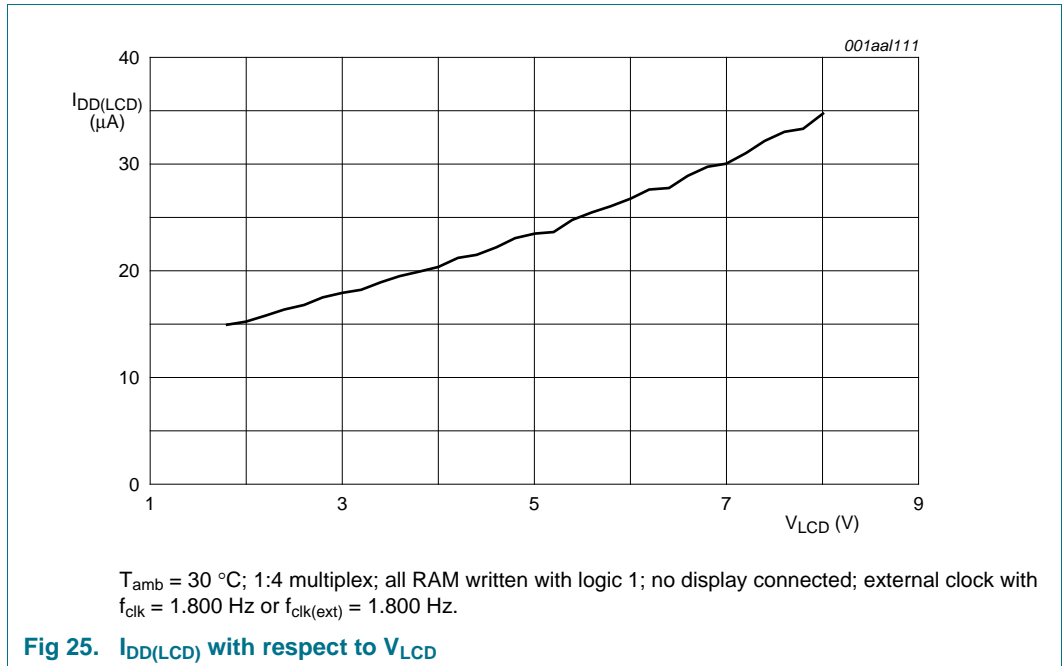

13. Dynamic characteristics

Table 22. Dynamic characteristics
 $V_{DD} = 1.8\text{ V to }5.5\text{ V}; V_{SS} = 0\text{ V}; V_{LCD} = 1.8\text{ V to }8.0\text{ V}; T_{amb} = -40\text{ }^{\circ}\text{C to }+95\text{ }^{\circ}\text{C};$ unless otherwise specified.

Symbol	Parameter	Conditions	Min	Typ	Max	Unit
$f_{clk(int)}$	internal clock frequency	on pin CLK; display enabled; $V_{DD} = 5\text{ V} \pm 0.5\text{ V}$	[1][2][3] 1600	1800	2060	Hz
$f_{clk(ext)}$	external clock frequency		[4] 700	-	5000	Hz
$t_{clk(H)}$	HIGH-level clock time	external clock source used	100	-	-	μs
$t_{clk(L)}$	LOW-level clock time	external clock source used	100	-	-	μs
Δf_{fr}	frame frequency variation	$V_{DD} = 5\text{ V} \pm 0.5\text{ V}$				
		$f_{fr} = 75\text{ Hz};$ $T_{amb} = 30\text{ }^{\circ}\text{C}$	-3.9	-	+3.9	%
		$f_{fr} = 70.3\text{ Hz};$ $T_{amb} = 95\text{ }^{\circ}\text{C}$	-5.2	-	+5.2	%
		$f_{fr} = 80\text{ Hz};$ $T_{amb} = -40\text{ }^{\circ}\text{C}$	-6.3	-	+7.3	%
$t_{PD(SYNC_N)}$	$\overline{\text{SYNC}}$ propagation delay		-	30	-	ns
t_{SYNC_NL}	$\overline{\text{SYNC}}$ LOW time		100	-	-	μs
$t_{PD(drv)}$	driver propagation delay	$V_{LCD} = 5\text{ V}$	-	10	-	μs
Timing characteristics: I²C-bus[5]						
f_{SCL}	SCL clock frequency		-	-	400	kHz
t_{BUF}	bus free time between a STOP and START condition		1.3	-	-	μs
$t_{HD;STA}$	hold time (repeated) START condition		0.6	-	-	μs
$t_{SU;STA}$	set-up time for a repeated START condition		0.6	-	-	μs
$t_{VD;ACK}$	data valid acknowledge time		-	-	0.9	μs
t_{LOW}	LOW period of the SCL clock		1.3	-	-	μs
t_{HIGH}	HIGH period of the SCL clock		0.6	-	-	μs
t_f	fall time	of both SDA and SCL signals	-	-	0.3	μs
t_r	rise time	of both SDA and SCL signals	-	-	0.3	μs
C_b	capacitive load for each bus line		-	-	400	pF
$t_{SU;DAT}$	data set-up time		200	-	-	ns
$t_{HD;DAT}$	data hold time		0	-	-	ns
$t_{SU;STO}$	set-up time for STOP condition		0.6	-	-	μs
t_{SP}	pulse width of spikes that must be suppressed by the input filter		-	-	50	ns

[1] Typical output duty factor: 50 % measured at the CLK output pin.

[2] For the respective frame frequency f_{fr} , see [Table 12](#).

[3] For the characteristics of V_{DD} at a fixed temperature or of the temperature at a fixed V_{DD} , see [Figure 26](#) and [Figure 27](#).

[4] For $f_{clk(ext)} > 4\text{ kHz}$, it is recommended to use an external pull-up resistor between pin $\overline{\text{SYNC}}$ and pin V_{DD} . The value of the resistor should be between 100 k Ω and 1 M Ω .

[5] All timing values are valid within the operating supply voltage and ambient temperature range and are referenced to V_{IL} and V_{IH} with an input voltage swing of V_{SS} to V_{DD} .

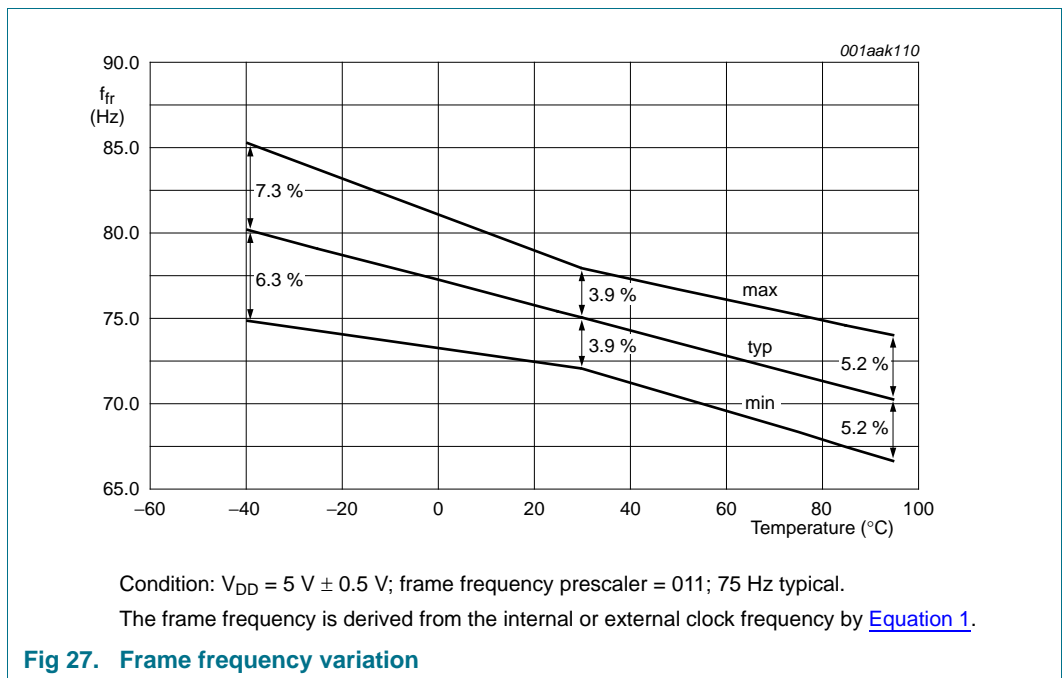
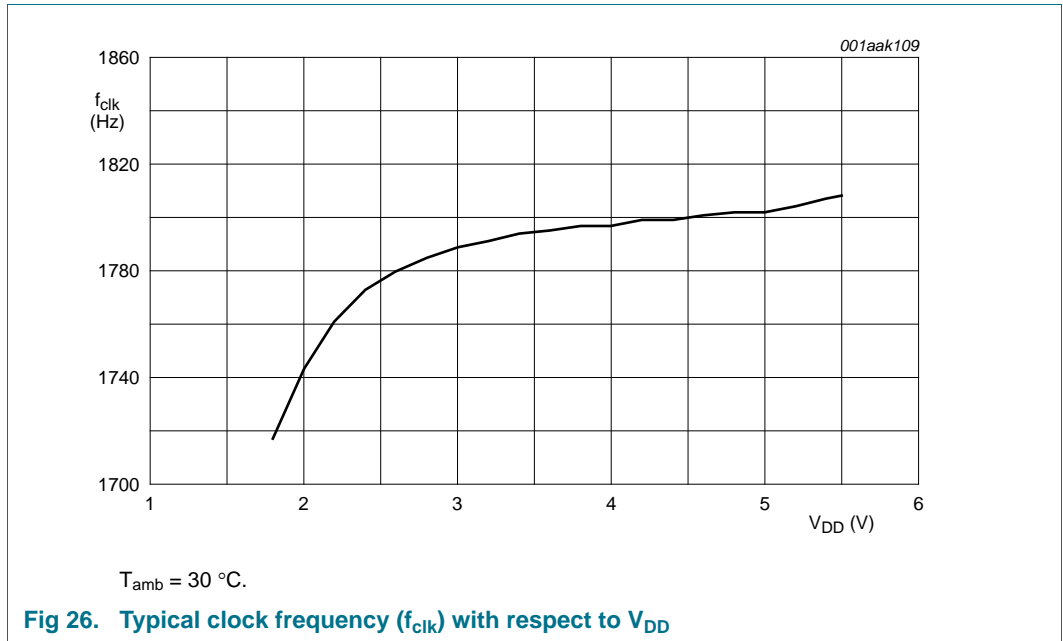

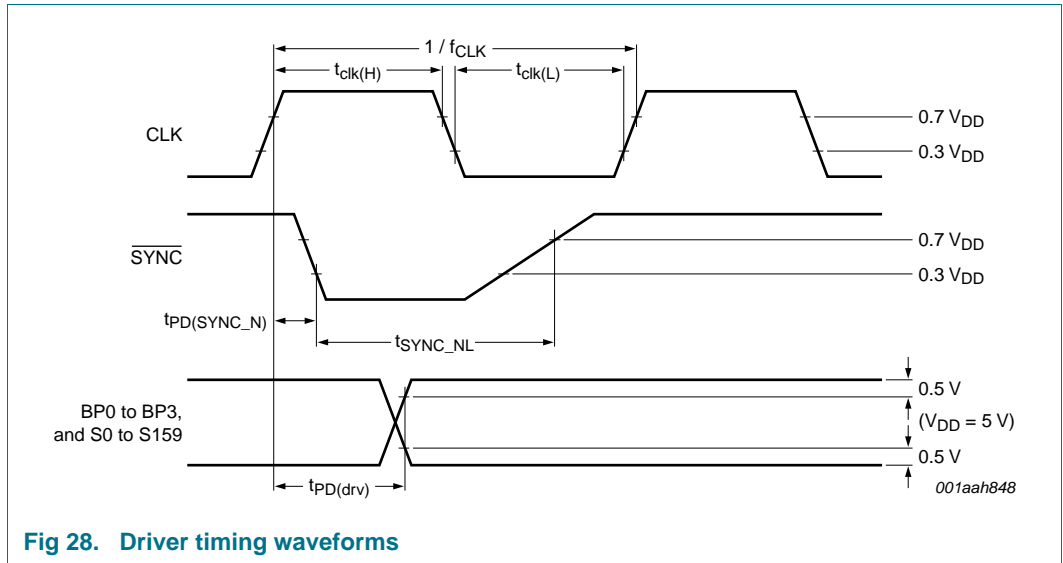

Fig 28. Driver timing waveforms

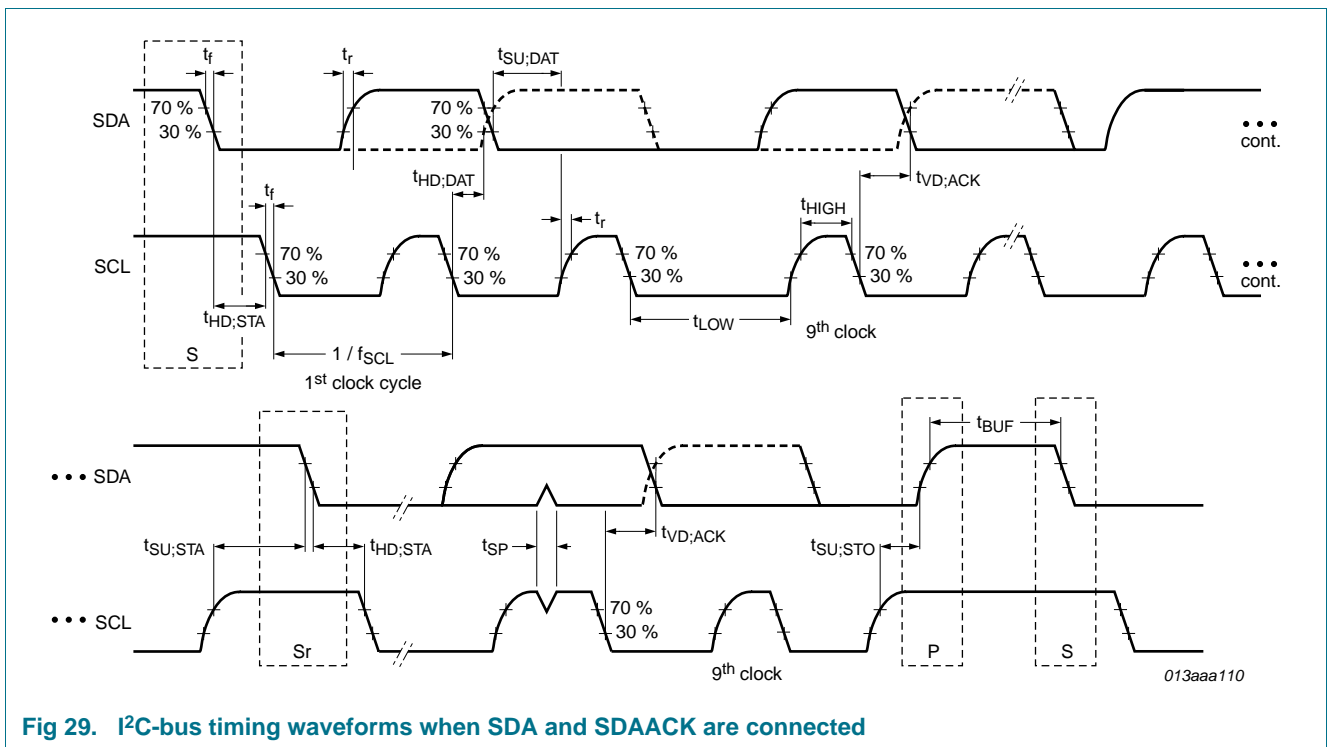

Fig 29. I²C-bus timing waveforms when SDA and SDAACK are connected

14. Application information

14.1 Pull-up resistor sizing on I²C-bus

14.1.1 Max value of pull-up resistor

The bus capacitance (C_b) is the total capacitance of wire, connections, and pins. This capacitance on pin SDA limits the maximum value of the pull-up resistor (R_{PU}) due to the specified rise time.

According to the I²C-bus specification the rise time (t_r) is defined between the V_{DD} -related input threshold of $V_{IL} = 0.3V_{DD}$ and $V_{IH} = 0.7V_{DD}$. The value for $t_{r(max)}$ is 300 ns.

t_r is calculated with [Equation 7](#):

$$t_r = t2 - t1 \tag{7}$$

whereas $t1$ and $t2$ are the time since the charging started. The values for $t1$ and $t2$ are derivatives of the functions $V(t1)$ and $V(t2)$:

$$V(t1) = 0.3V_{DD} = V_{DD}(1 - e^{-t1/R_{PU}C_b}) \tag{8}$$

$$V(t2) = 0.7V_{DD} = V_{DD}(1 - e^{-t2/R_{PU}C_b}) \tag{9}$$

with the results of

$$t1 = -R_{PU}C_b \times \ln(0.7) \tag{10}$$

$$t2 = -R_{PU}C_b \times \ln(0.3) \tag{11}$$

$$t_r = -R_{PU}C_b \times \ln(0.3) + R_{PU}C_b \times \ln(0.7) \tag{12}$$

$R_{PU(max)}$ is a function of the rise time (t_r) and the bus capacitance (C_b) and is calculated with [Equation 13](#):

$$R_{PU(max)} = \frac{t_r}{0.8473C_b} = \frac{300 \times 10^{-9}}{0.8473C_b} \tag{13}$$

14.1.2 Min value of pull-up resistor

The supply voltage limits the minimum value of resistor R_{PU} due to the specified minimum sink current (see value of I_{OL} on pin SDAACK in [Table 21 on page 35](#)). $R_{PU(min)}$ as a function of V_{DD} is calculated with [Equation 14](#):

$$R_{PU(min)} = \frac{V_{DD} - V_{OL}}{I_{OL}} \tag{14}$$

The designer now has the minimum and maximum value of R_{PU} . The values for $R_{PU(max)}$ and $R_{PU(min)}$ are shown in [Figure 30](#) and [Figure 31](#).

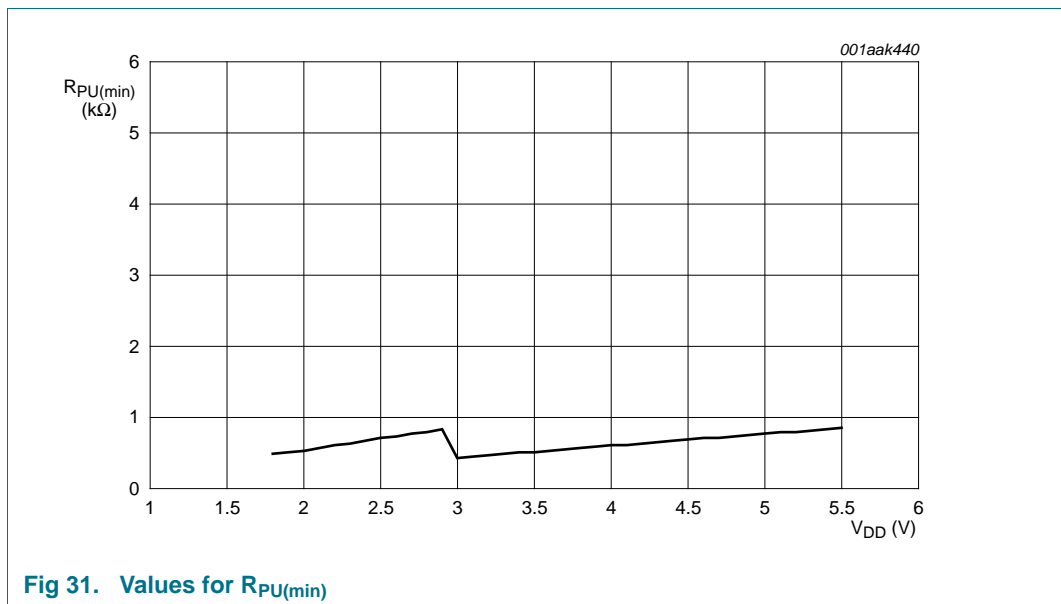
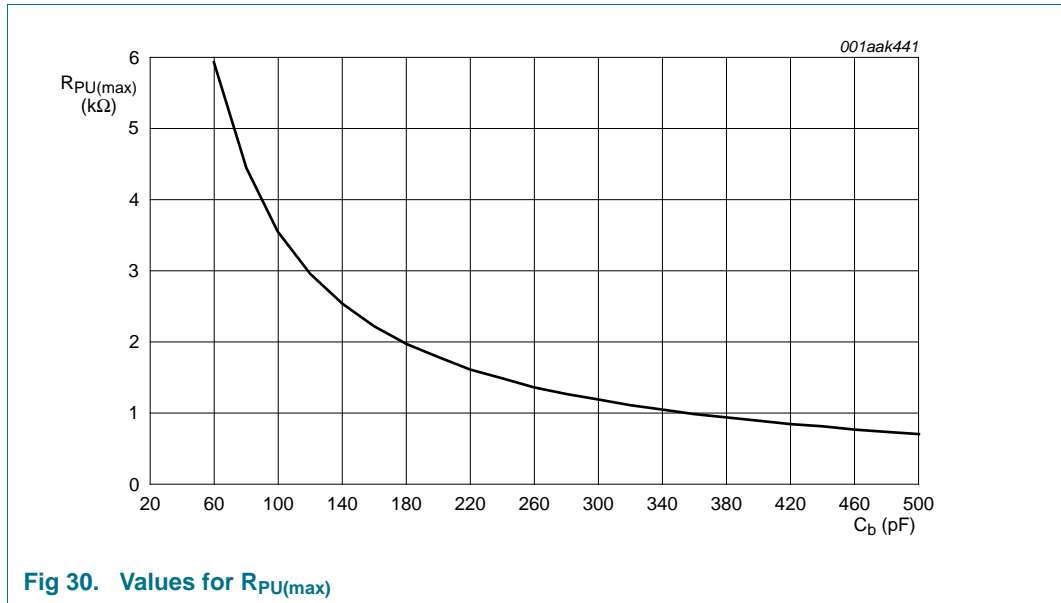

14.2 ITO track resistance

If an application requires to have a low V_{DD} supply voltage compared to the V_{LCD} supply voltage, it is recommended to increase the ITO resistance on the V_{LCD} supply track in order to reduce the noise induced on the V_{SS} line when display is enabled. A low V_{DD} voltage supply and noise peaks on V_{SS} induced by display activities may introduce disturbances into the I²C communication with the microcontroller.

Figure 32 shows that, when the ITO resistance of the V_{SS} pin has a certain value, it is indicated to have a higher ITO resistance on the V_{LCD} track, especially if V_{LCD} (for example, 9 V) is sharply higher than V_{DD} (for example, 1.8 V). With a higher ITO resistance on the V_{LCD} track, the noise spikes induced to the V_{SS} of the PCA85132 are getting smaller and the functionality is less affected.

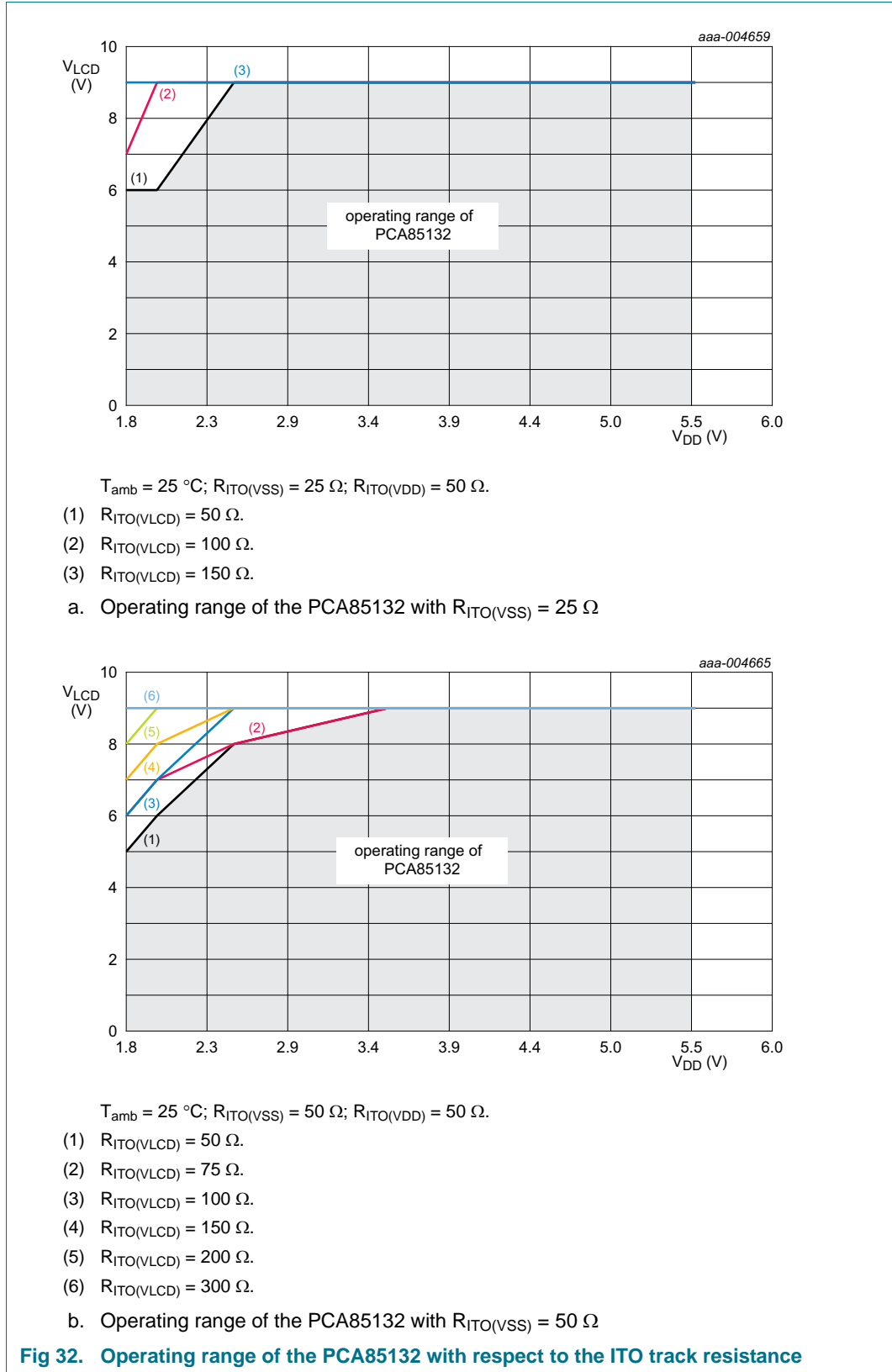

14.3 SDA and SDAACK configuration

The Serial Data line (SDA) and the I²C-bus acknowledge line (SDAACK) are split. Both lines can be connected together to facilitate a single-line SDA.

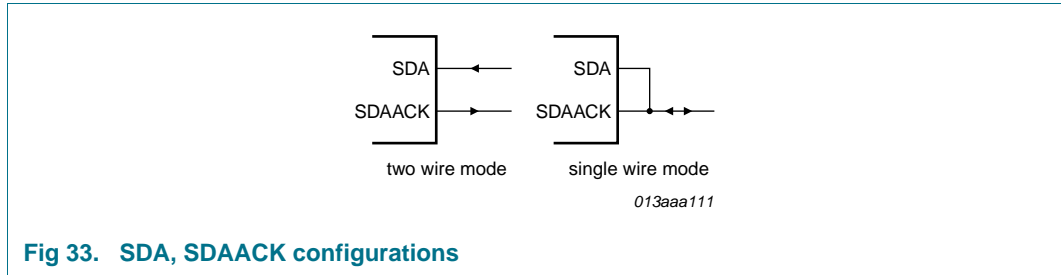

Fig 33. SDA, SDAACK configurations

14.4 Cascaded operation

In large display configurations, up to 8 PCA85132 can be distinguished on the same I²C-bus by using the 2-bit hardware subaddress (A0 and A1) and the programmable I²C-bus slave address (SA0).

Table 23. Addressing cascaded PCA85132

Cluster	Bit SA0	Pin A1	Pin A0	Device
1	0	0	0	0
		0	1	1
		1	0	2
		1	1	3
2	1	0	0	4
		0	1	5
		1	0	6
		1	1	7

When cascaded PCA85132 are synchronized, they can share the backplane signals from one of the devices in the cascade. Such an arrangement is cost-effective in large LCD applications since the backplane outputs of only one device need to be through-plated to the backplane electrodes of the display. The other PCA85132 of the cascade contribute additional segment outputs but their backplane outputs are left open-circuit (see [Figure 34 on page 46](#)).

For display sizes that are not multiple of 640 elements, a mixed cascaded system can be considered containing only devices like PCA85132 and PCA85133. Depending on the application, one must take care of the software commands compatibility and pin connection compatibility.

The $\overline{\text{SYNC}}$ line is provided to maintain the correct synchronization between all cascaded PCA85132. This synchronization is guaranteed after the Power-On Reset (POR). The only time that $\overline{\text{SYNC}}$ is likely to be needed is if synchronization is accidentally lost (for example, by noise in adverse electrical environments, or by the definition of a multiplex mode when PCA85132 with different SA0 levels are cascaded). $\overline{\text{SYNC}}$ is organized as an input/output pin; the output selection being realized as an open-drain driver with an internal pull-up resistor. A PCA85132 asserts the $\overline{\text{SYNC}}$ line at the onset of its last active backplane signal and monitors the $\overline{\text{SYNC}}$ line at all other times. Should synchronization in

the cascade be lost, it is restored by the first PCA85132 to assert $\overline{\text{SYNC}}$. The timing relationship between the backplane waveforms and the $\overline{\text{SYNC}}$ signal for the various drive modes of the PCA85132 are shown in [Figure 36 on page 48](#).

When using an external clock signal with high frequencies ($f_{\text{clk(EXT)}} > 4 \text{ kHz}$), it is recommended to have an external pull-up resistor between pin $\overline{\text{SYNC}}$ and pin V_{DD} (see [Table 22 on page 38](#)). This resistor should be present even when no cascading configuration is used! When using it in a cascaded configuration, care must be taken not to route the $\overline{\text{SYNC}}$ signal to close to noisy signals.

The contact resistance between the $\overline{\text{SYNC}}$ pads of cascaded devices must be controlled. If the resistance is too high, the device is not able to synchronize properly. This is particularly applicable to COG applications. [Table 24](#) shows the limiting values for contact resistance.

Table 24. $\overline{\text{SYNC}}$ contact resistance

Number of devices	Maximum contact resistance
2	6000 Ω
3 to 5	2200 Ω
6 to 8	1200 Ω

In the cascaded applications, the OSC pin of the PCA85132 with subaddress 0 is connected to V_{SS} so that this device uses its internal clock to generate a clock signal at the CLK pin. The other PCA85132 devices are having the OSC pin connected to V_{DD} , meaning that these devices are ready to receive external clock, the signal being provided by the device with subaddress 0.

If the master is providing the clock signal to the slave devices, care must be taken that the sending of display enable or disable is received by both, the master and the slaves at the same time. When the display is disabled, the output from pin CLK is disabled too. The disconnection of the clock may result in a DC component for the display.

Alternatively, the schematic can be also constructed such that all the devices have OSC pin connected to V_{DD} and thus an external CLK being provided for the system (all devices connected to the same external CLK).

A configuration where $\overline{\text{SYNC}}$ is connected but all PCA85132 are using their internal clock (OSC pin tied to V_{SS}) should not be used and may lead to display artifacts!

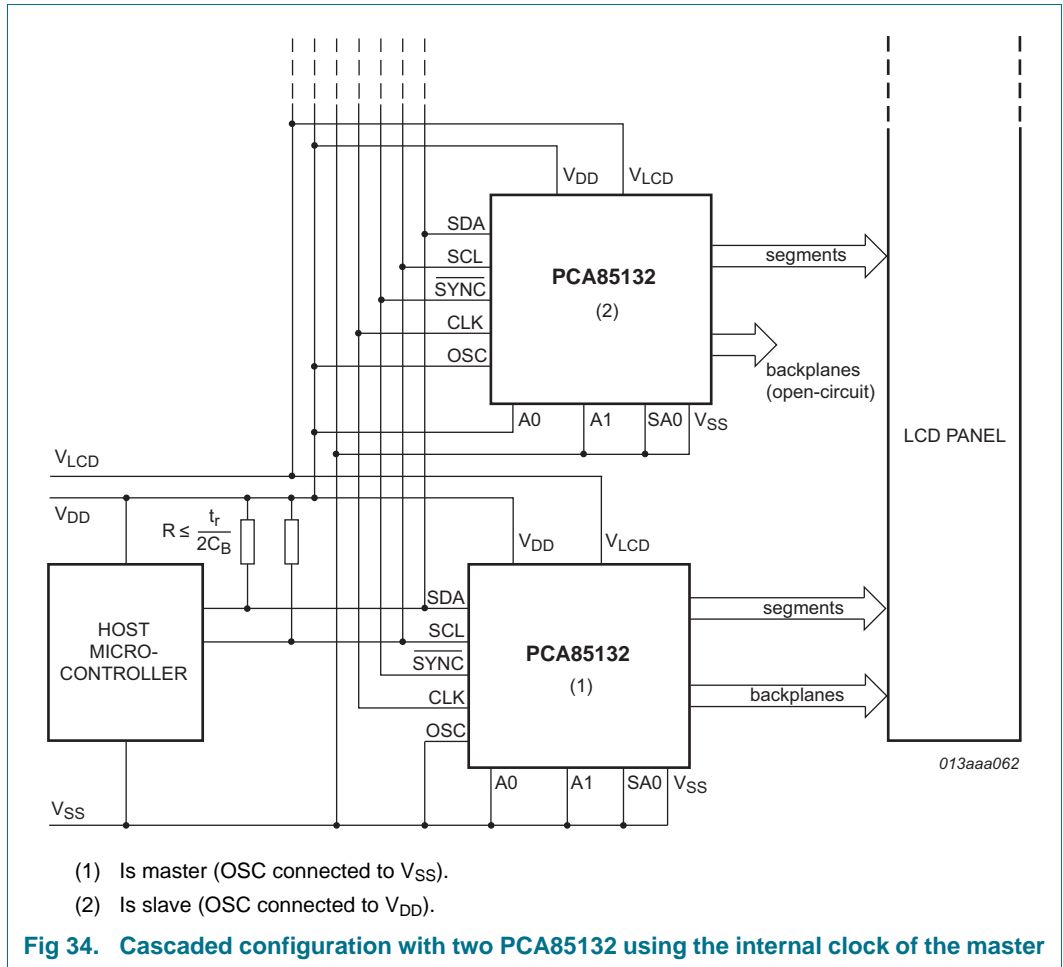

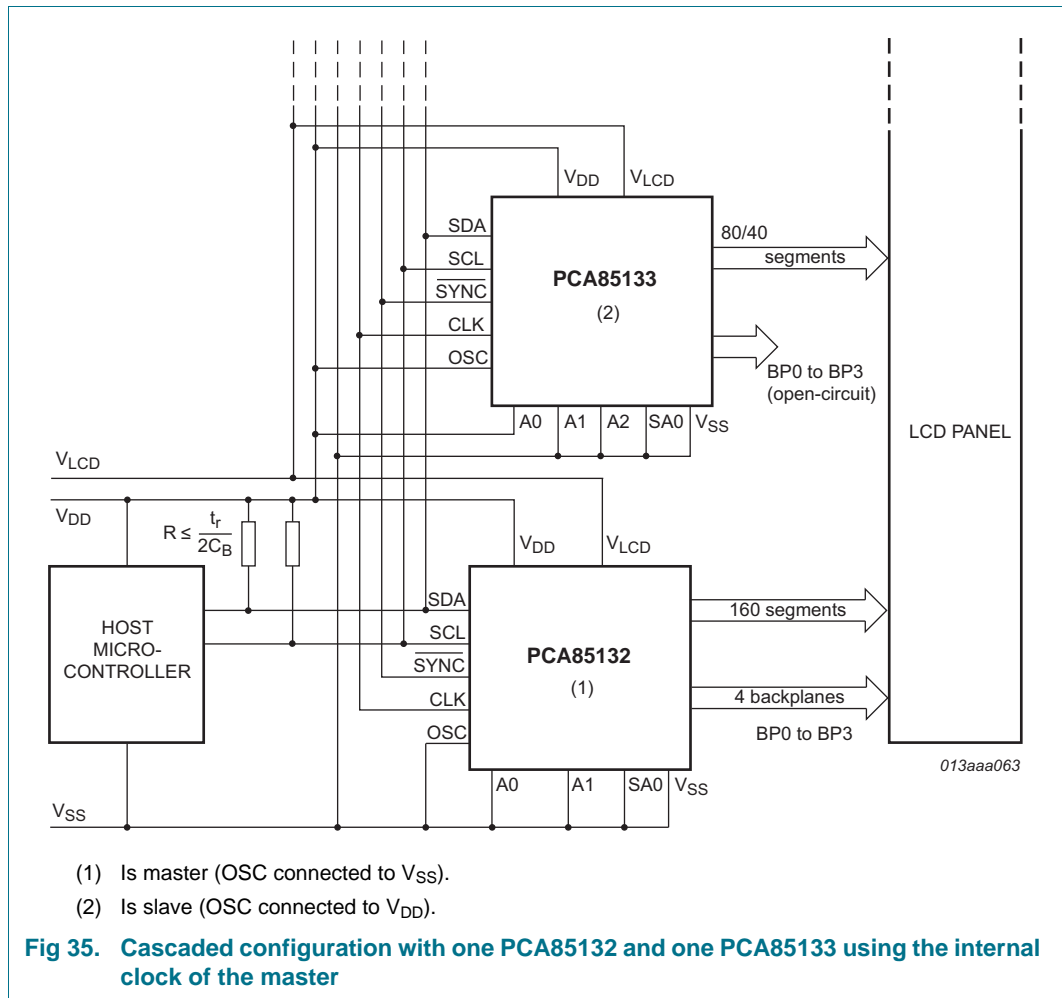

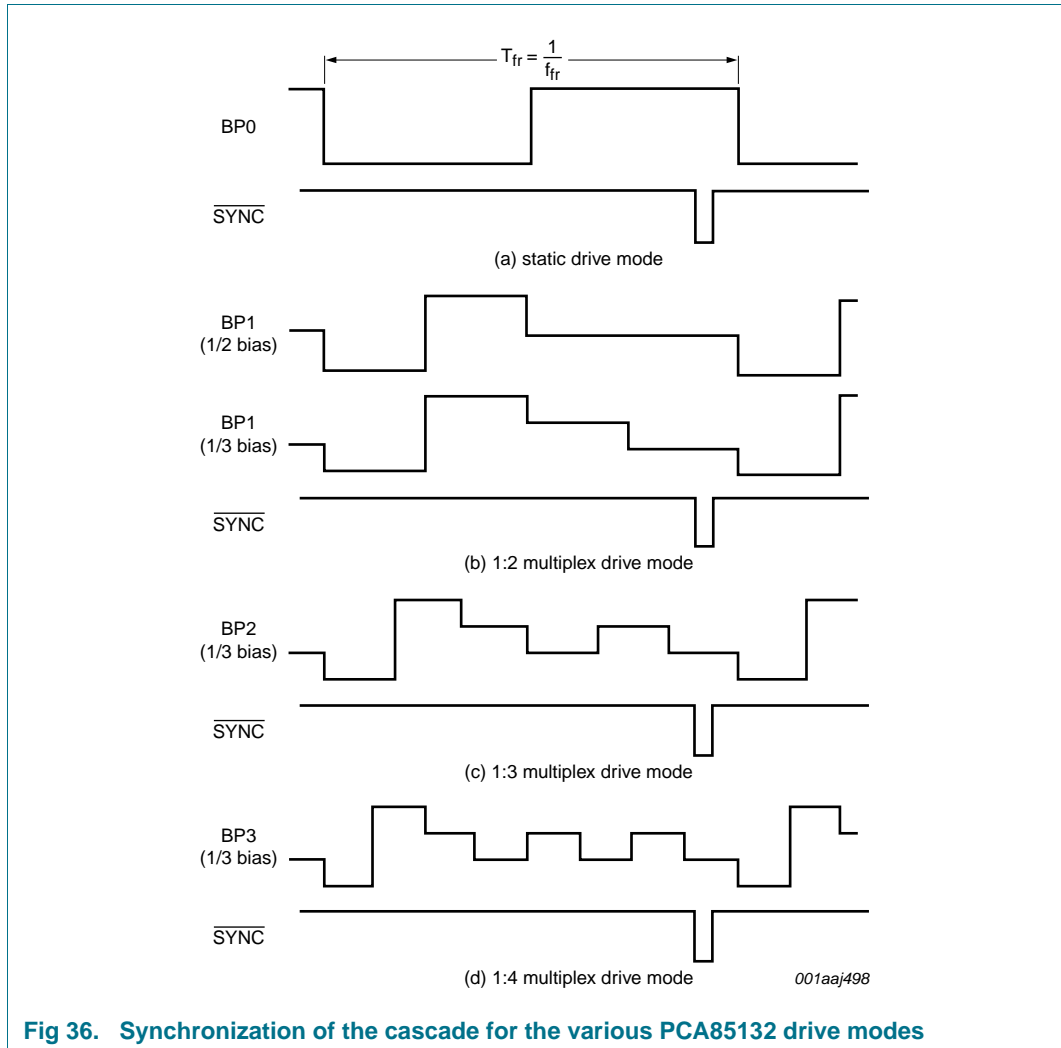

Fig 36. Synchronization of the cascade for the various PCA85132 drive modes

15. Test information

15.1 Quality information

This product has been qualified in accordance with the Automotive Electronics Council (AEC) standard Q100 - *Failure mechanism based stress test qualification for integrated circuits*, and is suitable for use in automotive applications.

16. Bare die outline

Bare die; 197 bumps; 6.5 x 1.16 x 0.40 mm

PCA85132U

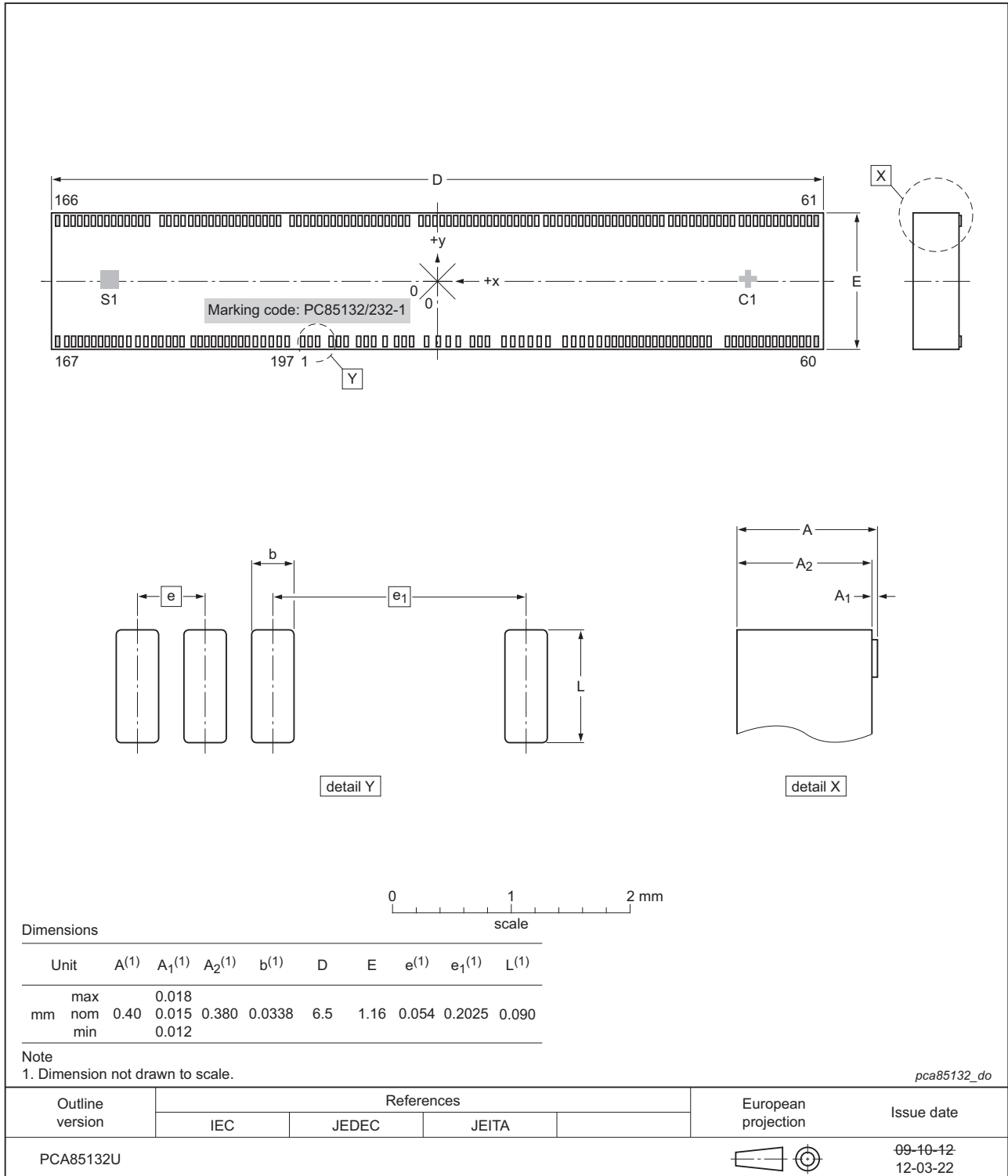

Fig 37. Bare die outline of PCA85132

Table 25. Bump locations

All x/y coordinates represent the position of the center of each bump with respect to the center (x/y = 0) of the chip; see [Figure 37](#).

Symbol	Bump	X (μm)	Y (μm)	Symbol	Bump	X (μm)	Y (μm)
SDAACK	1	-1165.3	-481.5	S68	100	750.2	481.5
SDAACK	2	-1111.3	-481.5	S69	101	696.2	481.5
SDAACK	3	-1057.3	-481.5	S70	102	642.2	481.5
SDA	4	-854.8	-481.5	S71	103	588.2	481.5
SDA	5	-800.8	-481.5	S72	104	534.2	481.5
SDA	6	-746.8	-481.5	S73	105	480.2	481.5
SCL	7	-575.8	-481.5	S74	106	426.2	481.5
SCL	8	-521.8	-481.5	S75	107	372.2	481.5
SCL	9	-467.8	-481.5	S76	108	318.2	481.5
CLK	10	-316.2	-481.5	S77	109	264.2	481.5
V _{DD}	11	-204.1	-481.5	S78	110	210.2	481.5
V _{DD}	12	-150.1	-481.5	S79	111	156.2	481.5
V _{DD}	13	-96.1	-481.5	BP0	112	86.8	481.5
SYNC	14	6.9	-481.5	BP2	113	32.8	481.5
OSC	15	119.4	-481.5	BP1	114	-21.2	481.5
T1	16	203.1	-481.5	BP3	115	-75.2	481.5
T2	17	286.8	-481.5	S80	116	-190.7	481.5
T3	18	389.9	-481.5	S81	117	-244.7	481.5
T3	19	443.9	-481.5	S82	118	-298.7	481.5
T3	20	497.9	-481.5	S83	119	-352.7	481.5
A0	21	640.5	-481.5	S84	120	-406.7	481.5
A1	22	724.2	-481.5	S85	121	-460.7	481.5
SA0	23	807.9	-481.5	S86	122	-514.7	481.5
V _{SS}	24	893.0	-481.5	S87	123	-568.7	481.5
V _{SS}	25	947.0	-481.5	S88	124	-622.7	481.5
V _{SS}	26	1001.0	-481.5	S89	125	-676.7	481.5
V _{LCD}	27	1107.2	-481.5	S90	126	-730.7	481.5
V _{LCD}	28	1161.2	-481.5	S91	127	-784.7	481.5
V _{LCD}	29	1215.2	-481.5	S92	128	-838.7	481.5
BP2	30	1303.4	-481.5	S93	129	-892.7	481.5
BP0	31	1357.4	-481.5	S94	130	-946.7	481.5
S0	32	1411.4	-481.5	S95	131	-1000.7	481.5
S1	33	1465.4	-481.5	S96	132	-1054.7	481.5
S2	34	1519.4	-481.5	S97	133	-1108.7	481.5
S3	35	1573.4	-481.5	S98	134	-1224.2	481.5
S4	36	1627.4	-481.5	S99	135	-1278.2	481.5
S5	37	1681.4	-481.5	S100	136	-1332.2	481.5
S6	38	1735.4	-481.5	S101	137	-1386.2	481.5
S7	39	1789.4	-481.5	S102	138	-1440.2	481.5

Table 25. Bump locations ...continued

All x/y coordinates represent the position of the center of each bump with respect to the center (x/y = 0) of the chip; see [Figure 37](#).

Symbol	Bump	X (μm)	Y (μm)	Symbol	Bump	X (μm)	Y (μm)
S8	40	1843.4	-481.5	S103	139	-1494.2	481.5
S9	41	1897.4	-481.5	S104	140	-1548.2	481.5
S10	42	1951.4	-481.5	S105	141	-1602.2	481.5
S11	43	2005.4	-481.5	S106	142	-1656.2	481.5
S12	44	2059.4	-481.5	S107	143	-1710.2	481.5
S13	45	2113.4	-481.5	S108	144	-1764.2	481.5
S14	46	2167.4	-481.5	S109	145	-1818.2	481.5
S15	47	2221.4	-481.5	S110	146	-1872.2	481.5
S16	48	2363.9	-481.5	S111	147	-1926.2	481.5
S17	49	2417.9	-481.5	S112	148	-1980.2	481.5
S18	50	2471.9	-481.5	S113	149	-2034.2	481.5
S19	51	2525.9	-481.5	S114	150	-2088.2	481.5
S20	52	2579.9	-481.5	S115	151	-2142.2	481.5
S21	53	2633.9	-481.5	S116	152	-2284.7	481.5
S22	54	2687.9	-481.5	S117	153	-2338.7	481.5
S23	55	2741.9	-481.5	S118	154	-2392.7	481.5
S24	56	2795.9	-481.5	S119	155	-2446.7	481.5
S25	57	2849.9	-481.5	S120	156	-2500.7	481.5
S26	58	2903.9	-481.5	S121	157	-2554.7	481.5
S27	59	2957.9	-481.5	S122	158	-2608.7	481.5
S28	60	3011.9	-481.5	S123	159	-2662.7	481.5
S29	61	3067.7	481.5	S124	160	-2716.7	481.5
S30	62	3013.7	481.5	S125	161	-2770.7	481.5
S31	63	2959.7	481.5	S126	162	-2824.7	481.5
S32	64	2905.7	481.5	S127	163	-2878.7	481.5
S33	65	2851.7	481.5	S128	164	-2932.7	481.5
S34	66	2797.7	481.5	S129	165	-2986.7	481.5
S35	67	2743.7	481.5	S130	166	-3040.7	481.5
S36	68	2689.7	481.5	S131	167	-3025.2	-481.5
S37	69	2635.7	481.5	S132	168	-2971.2	-481.5
S38	70	2520.2	481.5	S133	169	-2917.2	-481.5
S39	71	2466.2	481.5	S134	170	-2863.2	-481.5
S40	72	2412.2	481.5	S135	171	-2809.2	-481.5
S41	73	2358.2	481.5	S136	172	-2755.2	-481.5
S42	74	2304.2	481.5	S137	173	-2701.2	-481.5
S43	75	2250.2	481.5	S138	174	-2647.2	-481.5
S44	76	2196.2	481.5	S139	175	-2593.2	-481.5
S45	77	2142.2	481.5	S140	176	-2539.2	-481.5
S46	78	2088.2	481.5	S141	177	-2485.2	-481.5

Table 25. Bump locations ...continued

All x/y coordinates represent the position of the center of each bump with respect to the center (x/y = 0) of the chip; see [Figure 37](#).

Symbol	Bump	X (μm)	Y (μm)	Symbol	Bump	X (μm)	Y (μm)
S47	79	2034.2	481.5	S142	178	-2431.2	-481.5
S48	80	1891.7	481.5	S143	179	-2377.2	-481.5
S49	81	1837.7	481.5	S144	180	-2234.7	-481.5
S50	82	1783.7	481.5	S145	181	-2180.7	-481.5
S51	83	1729.7	481.5	S146	182	-2126.7	-481.5
S52	84	1675.7	481.5	S147	183	-2072.7	-481.5
S53	85	1621.7	481.5	S148	184	-2018.7	-481.5
S54	86	1567.7	481.5	S149	185	-1964.7	-481.5
S55	87	1513.7	481.5	S150	186	-1910.7	-481.5
S56	88	1459.7	481.5	S151	187	-1856.7	-481.5
S57	89	1405.7	481.5	S152	188	-1802.7	-481.5
S58	90	1351.7	481.5	S153	189	-1748.7	-481.5
S59	91	1297.7	481.5	S154	190	-1694.7	-481.5
S60	92	1243.7	481.5	S155	191	-1640.7	-481.5
S61	93	1189.7	481.5	S156	192	-1586.7	-481.5
S62	94	1135.7	481.5	S157	193	-1532.7	-481.5
S63	95	1081.7	481.5	S158	194	-1478.7	-481.5
S64	96	1027.7	481.5	S159	195	-1424.7	-481.5
S65	97	973.7	481.5	BP3	196	-1370.7	-481.5
S66	98	858.2	481.5	BP1	197	-1316.7	-481.5
S67	99	804.2	481.5				

The dummy pins are connected to the pins shown (see [Table 26](#)) but are not tested.

Table 26. Dummy bumps

All x/y coordinates represent the position of the center of each bump with respect to the center (x/y = 0) of the chip; see [Figure 37 on page 49](#).

Symbol	Connected to pin	X (μm)	Y (μm)
D1	S131	-3079.2	-481.5
D2	S28	3065.9	-481.5
D3	S29	3121.7	481.5
D4	S130	-3094.7	481.5

The alignment marks are shown in [Table 27](#).

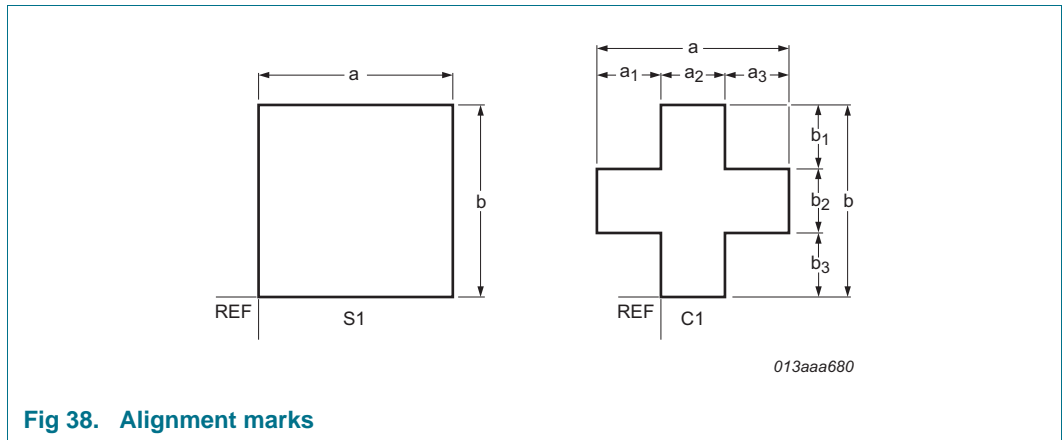

Table 27. Alignment marks

All x/y coordinates represent the position of the REF point (see [Figure 38](#)) with respect to the center (x/y = 0) of the chip; see [Figure 37 on page 49](#).

a	a ₁	a ₂	a ₃	b	b ₁	b ₂	b ₃	Coordinates		Unit
								X	Y	
Alignment mark S1										
121.5	-	-	-	121.5	-	-	-	-2733.75	-47.25	μm
Alignment mark C1										
121.5	36.45	48.6	36.45	121.5	36.45	48.6	36.45	2603.7	-47.25	μm

Table 28. Gold bump hardness

Type number	Min	Max	Unit ^[1]
PCA85132U/2DA/Q1	60	120	HV
PCA85132U/2DB/Q1	35	80	HV

[1] Pressure of diamond head: 10 g to 50 g.

17. Packing information

17.1 Tray information

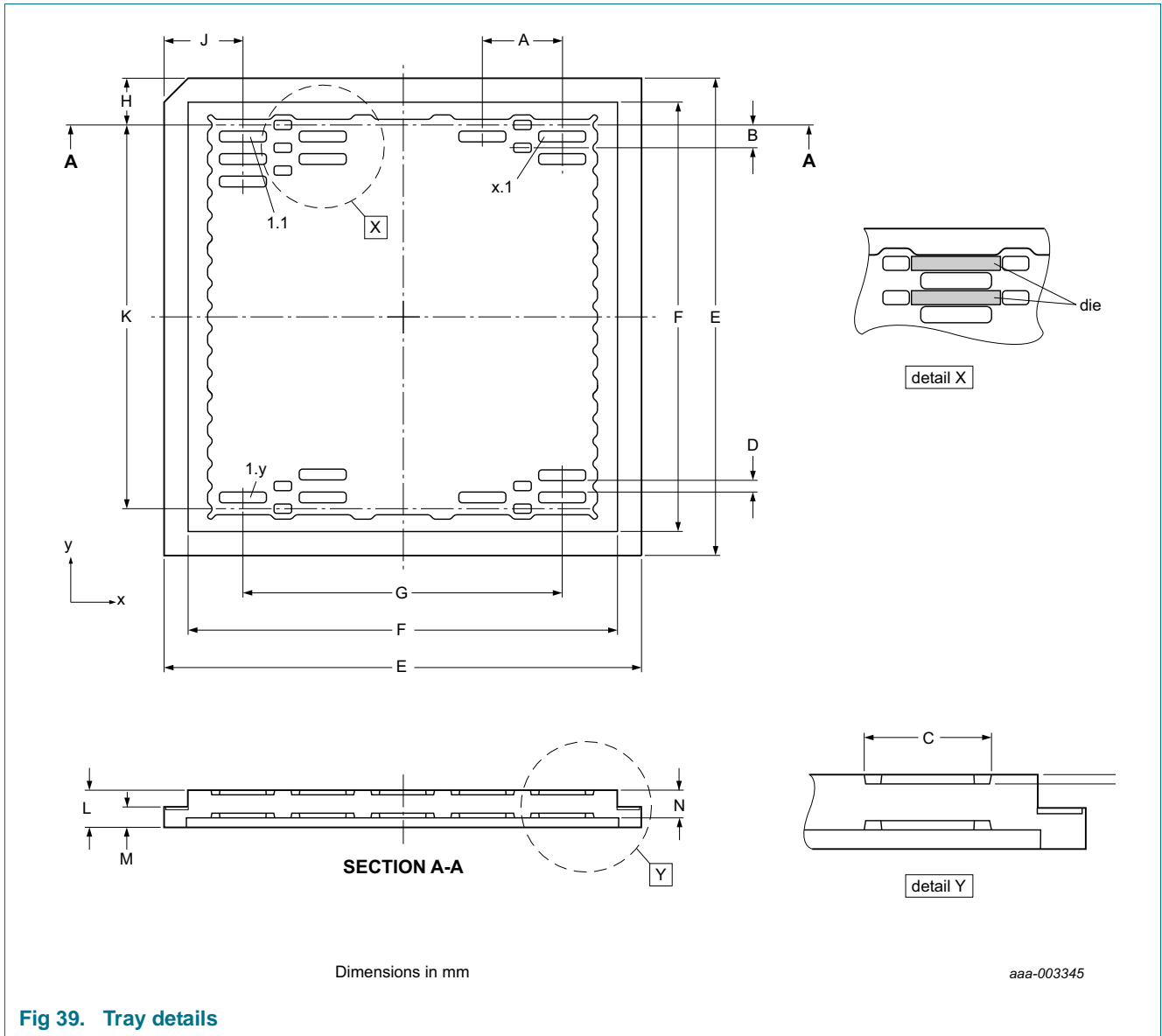

Fig 39. Tray details

Table 29. Description of tray details

Tray details are shown in [Figure 39](#).

Tray details														
Dimensions														
A	B	C	D	E	F	G	H	J	K	L	M	N	O	Unit
8.50	2.40	6.596	1.259	50.8	45.72	34.0	5.0	8.40	40.80	3.96	2.18	2.49	0.5	mm
Number of pockets														
x direction								y direction						
5								18						

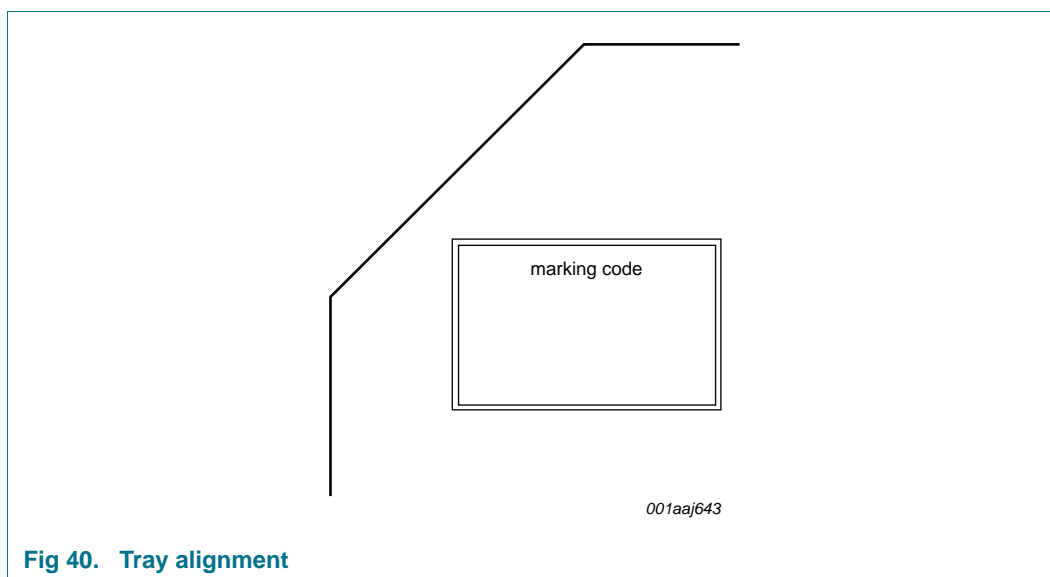

Fig 40. Tray alignment

18. Abbreviations

Table 30. Abbreviations

Acronym	Description
AEC	Automotive Electronics Council
COG	Chip-On-Glass
DC	Direct Current
HBM	Human Body Model
IC	Integrated Circuit
I ² C	Inter-Integrated Circuit
ITO	Indium Tin Oxide
LCD	Liquid Crystal Display
LSB	Least Significant Bit
MM	Machine Model
MSB	Most Significant Bit
POR	Power-On Reset
RC	Resistance and Capacitance
RAM	Random Access Memory
RMS	Root Mean Square
SCL	Serial CLock line
SDA	Serial DATa line

19. References

- [1] **AN10170** — Design guidelines for COG modules with NXP monochrome LCD drivers
- [2] **AN10706** — Handling bare die
- [3] **AN11267** — EMC and system level ESD design guidelines for LCD drivers
- [4] **IEC 60134** — Rating systems for electronic tubes and valves and analogous semiconductor devices
- [5] **IEC 61340-5** — Protection of electronic devices from electrostatic phenomena
- [6] **JESD22-A114** — Electrostatic Discharge (ESD) Sensitivity Testing Human Body Model (HBM)
- [7] **JESD22-A115** — Electrostatic Discharge (ESD) Sensitivity Testing Machine Model (MM)
- [8] **JESD78** — IC Latch-Up Test
- [9] **JESD625-A** — Requirements for Handling Electrostatic-Discharge-Sensitive (ESDS) Devices
- [10] **UM10204** — I²C-bus specification and user manual
- [11] **UM10569** — Store and transport requirements

20. Revision history

Table 31. Revision history

Document ID	Release date	Data sheet status	Change notice	Supersedes
PCA85132 v.3	20130711	Product data sheet	-	PCA85132 v.2
Modifications:	• Changed tray information (Section 17.1)			
PCA85132 v.2	20120905	Product data sheet	-	PCA85132 v.1
PCA85132 v.1	20100506	Product data sheet	-	-

21. Legal information

21.1 Data sheet status

Document status ^{[1][2]}	Product status ^[3]	Definition
Objective [short] data sheet	Development	This document contains data from the objective specification for product development.
Preliminary [short] data sheet	Qualification	This document contains data from the preliminary specification.
Product [short] data sheet	Production	This document contains the product specification.

[1] Please consult the most recently issued document before initiating or completing a design.

[2] The term 'short data sheet' is explained in section "Definitions".

[3] The product status of device(s) described in this document may have changed since this document was published and may differ in case of multiple devices. The latest product status information is available on the Internet at URL <http://www.nxp.com>.

21.2 Definitions

Draft — The document is a draft version only. The content is still under internal review and subject to formal approval, which may result in modifications or additions. NXP Semiconductors does not give any representations or warranties as to the accuracy or completeness of information included herein and shall have no liability for the consequences of use of such information.

Short data sheet — A short data sheet is an extract from a full data sheet with the same product type number(s) and title. A short data sheet is intended for quick reference only and should not be relied upon to contain detailed and full information. For detailed and full information see the relevant full data sheet, which is available on request via the local NXP Semiconductors sales office. In case of any inconsistency or conflict with the short data sheet, the full data sheet shall prevail.

Product specification — The information and data provided in a Product data sheet shall define the specification of the product as agreed between NXP Semiconductors and its customer, unless NXP Semiconductors and customer have explicitly agreed otherwise in writing. In no event however, shall an agreement be valid in which the NXP Semiconductors product is deemed to offer functions and qualities beyond those described in the Product data sheet.

21.3 Disclaimers

Limited warranty and liability — Information in this document is believed to be accurate and reliable. However, NXP Semiconductors does not give any representations or warranties, expressed or implied, as to the accuracy or completeness of such information and shall have no liability for the consequences of use of such information. NXP Semiconductors takes no responsibility for the content in this document if provided by an information source outside of NXP Semiconductors.

In no event shall NXP Semiconductors be liable for any indirect, incidental, punitive, special or consequential damages (including - without limitation - lost profits, lost savings, business interruption, costs related to the removal or replacement of any products or rework charges) whether or not such damages are based on tort (including negligence), warranty, breach of contract or any other legal theory.

Notwithstanding any damages that customer might incur for any reason whatsoever, NXP Semiconductors' aggregate and cumulative liability towards customer for the products described herein shall be limited in accordance with the *Terms and conditions of commercial sale* of NXP Semiconductors.

Right to make changes — NXP Semiconductors reserves the right to make changes to information published in this document, including without limitation specifications and product descriptions, at any time and without notice. This document supersedes and replaces all information supplied prior to the publication hereof.

Suitability for use in automotive applications — This NXP Semiconductors product has been qualified for use in automotive applications. Unless otherwise agreed in writing, the product is not designed, authorized or warranted to be suitable for use in life support, life-critical or safety-critical systems or equipment, nor in applications where failure or malfunction of an NXP Semiconductors product can reasonably be expected to result in personal injury, death or severe property or environmental damage. NXP Semiconductors and its suppliers accept no liability for inclusion and/or use of NXP Semiconductors products in such equipment or applications and therefore such inclusion and/or use is at the customer's own risk.

Applications — Applications that are described herein for any of these products are for illustrative purposes only. NXP Semiconductors makes no representation or warranty that such applications will be suitable for the specified use without further testing or modification.

Customers are responsible for the design and operation of their applications and products using NXP Semiconductors products, and NXP Semiconductors accepts no liability for any assistance with applications or customer product design. It is customer's sole responsibility to determine whether the NXP Semiconductors product is suitable and fit for the customer's applications and products planned, as well as for the planned application and use of customer's third party customer(s). Customers should provide appropriate design and operating safeguards to minimize the risks associated with their applications and products.

NXP Semiconductors does not accept any liability related to any default, damage, costs or problem which is based on any weakness or default in the customer's applications or products, or the application or use by customer's third party customer(s). Customer is responsible for doing all necessary testing for the customer's applications and products using NXP Semiconductors products in order to avoid a default of the applications and the products or of the application or use by customer's third party customer(s). NXP does not accept any liability in this respect.

Limiting values — Stress above one or more limiting values (as defined in the Absolute Maximum Ratings System of IEC 60134) will cause permanent damage to the device. Limiting values are stress ratings only and (proper) operation of the device at these or any other conditions above those given in the Recommended operating conditions section (if present) or the Characteristics sections of this document is not warranted. Constant or repeated exposure to limiting values will permanently and irreversibly affect the quality and reliability of the device.

Terms and conditions of commercial sale — NXP Semiconductors products are sold subject to the general terms and conditions of commercial sale, as published at <http://www.nxp.com/profile/terms>, unless otherwise agreed in a valid written individual agreement. In case an individual agreement is concluded only the terms and conditions of the respective agreement shall apply. NXP Semiconductors hereby expressly objects to applying the customer's general terms and conditions with regard to the purchase of NXP Semiconductors products by customer.

No offer to sell or license — Nothing in this document may be interpreted or construed as an offer to sell products that is open for acceptance or the grant, conveyance or implication of any license under any copyrights, patents or other industrial or intellectual property rights.

Export control — This document as well as the item(s) described herein may be subject to export control regulations. Export might require a prior authorization from competent authorities.

Translations — A non-English (translated) version of a document is for reference only. The English version shall prevail in case of any discrepancy between the translated and English versions.

Bare die — All die are tested on compliance with their related technical specifications as stated in this data sheet up to the point of wafer sawing and are handled in accordance with the NXP Semiconductors storage and transportation conditions. If there are data sheet limits not guaranteed, these will be separately indicated in the data sheet. There are no post-packing tests performed on individual die or wafers.

NXP Semiconductors has no control of third party procedures in the sawing, handling, packing or assembly of the die. Accordingly, NXP Semiconductors assumes no liability for device functionality or performance of the die or systems after third party sawing, handling, packing or assembly of the die. It is the responsibility of the customer to test and qualify their application in which the die is used.

All die sales are conditioned upon and subject to the customer entering into a written die sale agreement with NXP Semiconductors through its legal department.

21.4 Trademarks

Notice: All referenced brands, product names, service names and trademarks are the property of their respective owners.

I²C-bus — logo is a trademark of NXP B.V.

22. Contact information

For more information, please visit: <http://www.nxp.com>

For sales office addresses, please send an email to: salesaddresses@nxp.com

23. Tables

Table 1.	Ordering information	2
Table 2.	Ordering options	2
Table 3.	Marking codes	2
Table 4.	Pin description	5
Table 5.	Definition of PCA85132 commands	6
Table 6.	Mode-set - command bit description	6
Table 7.	Load-data-pointer-MSB - command bit description	7
Table 8.	Load-data-pointer-LSB - command bit description	7
Table 9.	Device-select - command bit description	7
Table 10.	Bank-select - command bit description	8
Table 11.	Blink-select - command bit description	8
Table 12.	Frequency-ctrl - command bit description	10
Table 13.	Blink frequencies	11
Table 14.	Selection of possible display configurations	12
Table 15.	Biasing characteristics	13
Table 16.	Standard RAM filling in 1:3 multiplex drive mode	25
Table 17.	Entire RAM filling by rewriting in 1:3 multiplex drive mode	25
Table 18.	I ² C slave address byte	30
Table 19.	Control byte description	31
Table 20.	Limiting values	34
Table 21.	Static characteristics	35
Table 22.	Dynamic characteristics	38
Table 23.	Addressing cascaded PCA85132	44
Table 24.	SYNC contact resistance	45
Table 25.	Bump locations	50
Table 26.	Dummy bumps	52
Table 27.	Alignment marks	53
Table 28.	Gold bump hardness	53
Table 29.	Description of tray details	54
Table 30.	Abbreviations	55
Table 31.	Revision history	57

24. Figures

Fig 1.	Block diagram of PCA85132	3
Fig 2.	Pinning diagram of PCA85132	4
Fig 3.	Frequency generation of the PCA85132	9
Fig 4.	Example of displays suitable for PCA85132	12
Fig 5.	Typical system configuration	12
Fig 6.	Electro-optical characteristic: relative transmission curve of the liquid	15
Fig 7.	Static drive mode waveforms	16
Fig 8.	Waveforms for the 1:2 multiplex drive mode with $\frac{1}{2}$ bias	17
Fig 9.	Waveforms for the 1:2 multiplex drive mode with $\frac{1}{3}$ bias	18
Fig 10.	Waveforms for the 1:3 multiplex drive mode with $\frac{1}{3}$ bias	19
Fig 11.	Waveforms for the 1:4 multiplex drive mode with $\frac{1}{3}$ bias	20
Fig 12.	Display RAM bitmap	22
Fig 13.	Relationships between LCD layout, drive mode, display RAM filling order, and display data transmitted over the I ² C-bus	23
Fig 14.	RAM banks in static and multiplex driving mode 1:2	26
Fig 15.	Bank selection	27
Fig 16.	Example of the Bank-select command with multiplex drive mode 1:2	27
Fig 17.	Bit transfer	28
Fig 18.	Definition of START and STOP conditions	29
Fig 19.	System configuration	29
Fig 20.	Acknowledgement on the I ² C-bus	30
Fig 21.	I ² C-bus protocol	31
Fig 22.	Control byte format	32
Fig 23.	Device protection diagram	33
Fig 24.	I _{DD} with respect to V _{DD}	36
Fig 25.	I _{DD(LCD)} with respect to V _{LCD}	37
Fig 26.	Typical clock frequency (f _{clk}) with respect to V _{DD}	39
Fig 27.	Frame frequency variation	39
Fig 28.	Driver timing waveforms	40
Fig 29.	I ² C-bus timing waveforms when SDA and SDAACK are connected	40
Fig 30.	Values for R _{PU(max)}	42
Fig 31.	Values for R _{PU(min)}	42
Fig 32.	Operating range of the PCA85132 with respect to the ITO track resistance	43
Fig 33.	SDA, SDAACK configurations	44
Fig 34.	Cascaded configuration with two PCA85132 using the internal clock of the master	46
Fig 35.	Cascaded configuration with one PCA85132 and one PCA85133 using the internal clock of the master	47
Fig 36.	Synchronization of the cascade for the various PCA85132 drive modes	48
Fig 37.	Bare die outline of PCA85132	49
Fig 38.	Alignment marks	53
Fig 39.	Tray details	54
Fig 40.	Tray alignment	55

25. Contents

1	General description	1	8.1	Bit transfer	28
2	Features and benefits	1	8.1.1	START and STOP conditions.	28
3	Ordering information	2	8.2	System configuration	29
3.1	Ordering options	2	8.3	Acknowledge	29
4	Marking	2	8.4	I ² C-bus controller	30
5	Block diagram	3	8.5	Input filters	30
6	Pinning information	4	8.6	I ² C-bus protocol	30
6.1	Pinning	4	9	Internal circuitry	33
6.2	Pin description	5	10	Safety notes	33
7	Functional description	6	11	Limiting values	34
7.1	Commands of PCA85132	6	12	Static characteristics	35
7.1.1	Command: mode-set	6	13	Dynamic characteristics	38
7.1.2	Command: load-data-pointer	7	14	Application information	41
7.1.3	Command: device-select	7	14.1	Pull-up resistor sizing on I ² C-bus	41
7.1.4	Command: bank-select	8	14.1.1	Max value of pull-up resistor	41
7.1.5	Command: blink-select	8	14.1.2	Min value of pull-up resistor	41
7.1.6	Clock frequency and timing	8	14.2	ITO track resistance	42
7.1.6.1	Clock source selection	8	14.3	SDA and SDAACK configuration	44
7.1.6.2	Internal clock	9	14.4	Cascaded operation	44
7.1.6.3	External clock	9	15	Test information	48
7.1.6.4	Frame frequency	10	15.1	Quality information	48
7.1.6.5	Command: frequency-ctrl	10	16	Bare die outline	49
7.1.6.6	Blinking	10	17	Packing information	54
7.2	Power-On Reset (POR)	11	17.1	Tray information	54
7.3	Possible display configurations	11	18	Abbreviations	55
7.3.1	LCD bias generator	13	19	References	56
7.3.2	Display register	13	20	Revision history	57
7.3.3	LCD voltage selector	13	21	Legal information	58
7.3.3.1	Electro-optical performance	14	21.1	Data sheet status	58
7.3.4	LCD drive mode waveforms	16	21.2	Definitions	58
7.3.4.1	Static drive mode	16	21.3	Disclaimers	58
7.3.4.2	1:2 multiplex drive mode	17	21.4	Trademarks	59
7.3.4.3	1:3 multiplex drive mode	19	22	Contact information	59
7.3.4.4	1:4 multiplex drive mode	20	23	Tables	60
7.4	Backplane and segment outputs	21	24	Figures	61
7.4.1	Backplane outputs	21	25	Contents	62
7.4.2	Segment outputs	21			
7.5	Display RAM	21			
7.5.1	Data pointer	24			
7.5.2	Subaddress counter	24			
7.5.3	RAM writing in 1:3 multiplex drive mode	25			
7.5.4	Bank selection	25			
7.5.4.1	Output bank selector	25			
7.5.4.2	Input bank selector	26			
7.5.4.3	RAM bank switching	26			
8	Characteristics of the I²C-bus	28			

Please be aware that important notices concerning this document and the product(s) described herein, have been included in section 'Legal information'.

© NXP B.V. 2013. All rights reserved.

For more information, please visit: <http://www.nxp.com>
 For sales office addresses, please send an email to: salesaddresses@nxp.com
 Date of release: 11 July 2013
 Document identifier: PCA85132