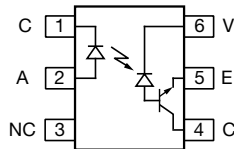
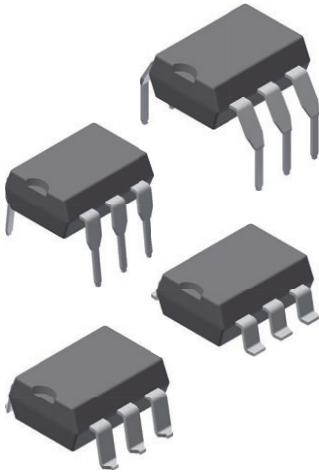


High Speed Optocoupler, Phototransistor Output, 1 MBd, 10 kV/μs CMR, Split Collector Transistor Output



DESCRIPTION

The SFH636 is an optocoupler with a GaAlAs infrared emitting diode, optically coupled to an integrated photo detector consisting of a photo diode and a high speed transistor in a DIP-6 plastic package. The device is functionally similar to 6N136 except there is no base connection and the foot print is different. Noise and common mode rejection performance is enhanced by not bringing out the base connection.

Signals can be transmitted between two electrically separated circuits up to frequencies of 2.0 MHz.

FEATURES

- High CMR of 10 kV/μs
- High speed optocoupler without base connection
- GaAlAs emitter
- Integrated detector with photo diode and transistor
- TTL and CMOS compatible
- Open collector output
- Supply voltage up to 30 V
- High CTR
- Good CTR linearity relative to forward current
- Low coupling capacitance
- Material categorization: for definitions of compliance please see www.vishay.com/doc?99912


RoHS
COMPLIANT

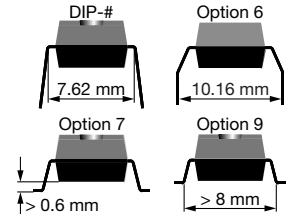
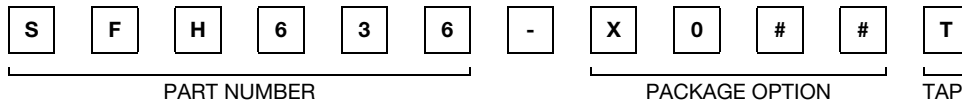
APPLICATIONS

- IGBT drivers and MOSFET driver stages
- Data communications
- Programmable controllers
- IPM drivers

AGENCY APPROVALS

- UL1577, file no. E52744, double protection
- cUL tested to CSA 22.2 bulletin 5A
- DIN EN 60747-5-5 (VDE 0884-5), available with option 1

ORDERING INFORMATION



AGENCY CERTIFIED/PACKAGE	CTR (%)
UL	≥ 19
DIP-6	SFH636
SMD-6, option 7	SFH636-X007, SFH636-X007T
SMD-6, option 9	SFH636-X009
VDE, UL	≥ 19
DIP-6	SFH636-X001
DIP-6, option 6	SFH636-X016
SMD-6, option 7	SFH636-X017, SFH636-X017T

Note

- Additional options may be possible, please contact sales office



ABSOLUTE MAXIMUM RATINGS ($T_{amb} = 25\text{ }^{\circ}\text{C}$, unless otherwise specified)				
PARAMETER	CONDITIONS	SYMBOL	VALUE	UNIT
INPUT				
Reverse voltage		V_R	3.0	V
DC forward current		I_F	25	mA
Surge forward current	$t_p \leq 1.0\text{ }\mu\text{s}$, 300 pulses/s	I_{FSM}	1.0	A
Power dissipation		P_{diss}	45	mW
OUTPUT				
Supply voltage		V_S	-0.5 to +30	V
Output voltage		V_O	-0.5 to +20	V
Output current		I_O	8	mA
Power dissipation		P_{diss}	100	mW
COUPLER				
Storage temperature range		T_{stg}	-55 to +150	$^{\circ}\text{C}$
Ambient temperature range		T_{amb}	-55 to +100	$^{\circ}\text{C}$
Junction temperature		T_j	100	$^{\circ}\text{C}$
Soldering temperature	Max. 10 s, dip soldering: distance to seating plane $\geq 1.5\text{ mm}$	T_{sld}	260	$^{\circ}\text{C}$

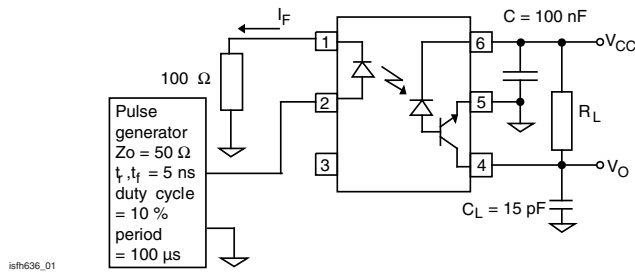
Note

- Stresses in excess of the absolute maximum ratings can cause permanent damage to the device. Functional operation of the device is not implied at these or any other conditions in excess of those given in the operational sections of this document. Exposure to absolute maximum ratings for extended periods of the time can adversely affect reliability.

ELECTRICAL CHARACTERISTICS ($T_{amb} = 0\text{ }^{\circ}\text{C}$ to $70\text{ }^{\circ}\text{C}$ unless otherwise specified, typ. values $T_{amb} = 25\text{ }^{\circ}\text{C}$)						
PARAMETER	TEST CONDITION	SYMBOL	MIN.	TYP.	MAX.	UNIT
input						
Forward voltage	$I_F = 16\text{ mA}$	V_F	-	1.5	1.8	V
Reverse current	$V_R = 3\text{ V}$	I_R	-	0.5	10	μA
Capacitance	$V_R = 0\text{ V}$, $f = 1\text{ MHz}$	C_O	-	125	-	pF
Thermal resistance		R_{thja}	-	700	-	K/W
output						
Logic high supply current	$I_F = 0\text{ V}$, V_O (open), $V_{CC} = 15\text{ V}$, $T_{amb} = 25\text{ }^{\circ}\text{C}$	I_{CCH}	-	0.01	1	μA
	$I_F = 0\text{ V}$, V_O (open), $V_{CC} = 15\text{ V}$	I_{CCH}	-	0.01	2	μA
Output current, output high	$I_F = 0\text{ V}$, V_O (open), $V_{CC} = 5.5\text{ V}$, $T_{amb} = 25\text{ }^{\circ}\text{C}$	I_{OH}	-	0.003	0.5	μA
	$I_F = 0\text{ V}$, V_O (open), $V_{CC} = 15\text{ V}$, $T_{amb} = 25\text{ }^{\circ}\text{C}$	I_{OH}	-	0.01	1	μA
	$I_F = 0\text{ V}$, V_O (open), $V_{CC} = 15\text{ V}$	I_{OH}	-		50	μA
Collector emitter capacitance	$V_{CE} = 5\text{ V}$, $f = 1\text{ MHz}$	C_{CE}	-	3	-	pF
Thermal resistance		R_{thja}	-	300	-	K/W
coupler						
Coupling capacitance		C_C	-	0.6	-	pF
Collector emitter saturation voltage	$I_F = 16\text{ mA}$, $I_O = 2.4\text{ mA}$, $V_{CC} = 4.5\text{ V}$; $T_{amb} = 25\text{ }^{\circ}\text{C}$	V_{OL}	-	0.1	0.4	V
Supply current, logic low	$I_F = 16\text{ mA}$, V_O open, $V_{CC} = 15\text{ V}$	I_{DD}	-	80	-	

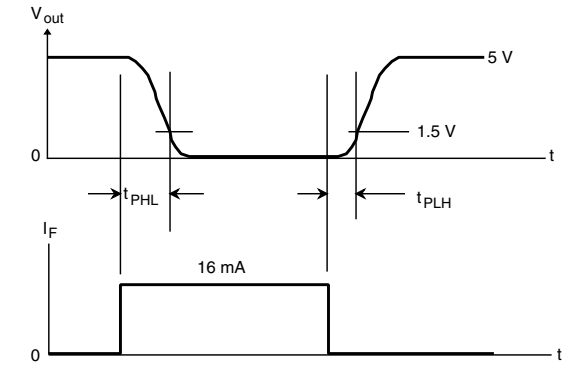
Note

- Minimum and maximum values are testing requirements. Typical values are characteristics of the device and are the result of engineering evaluation. Typical values are for information only and are not part of the testing requirements.



isfh636_01

Fig. 1 - Test Setup

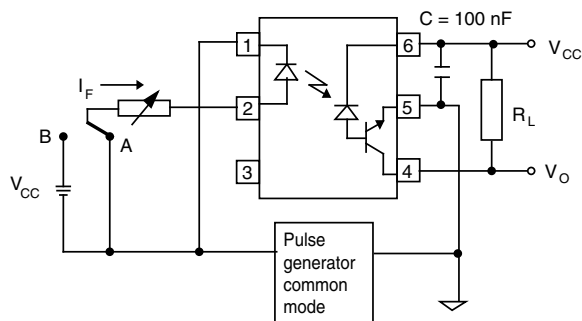


isfh636_02

Fig. 2 - Switching Time Measurement

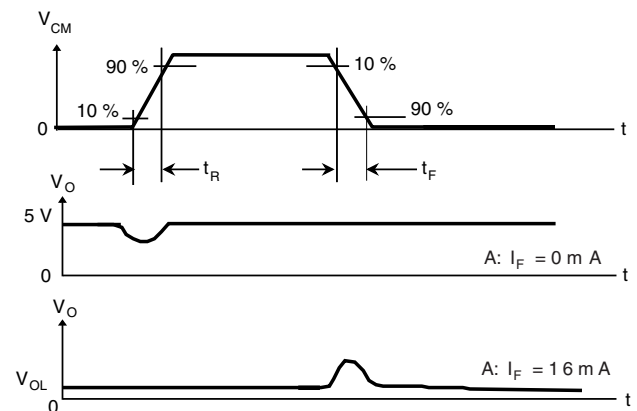
CURRENT TRANSFER RATIO ($T_{amb} = 0\text{ }^{\circ}\text{C}$ to $70\text{ }^{\circ}\text{C}$ unless otherwise specified, typ. values $T_{amb} = 25\text{ }^{\circ}\text{C}$)						
PARAMETER	TEST CONDITION	SYMBOL	MIN.	TYP.	MAX.	UNIT
I_C/I_F	$I_F = 16\text{ mA}$, $V_O = 0.4\text{ V}$, $V_{CC} = 4.5\text{ V}$, $T_{amb} = 25\text{ }^{\circ}\text{C}$	CTR	19	30	-	%
	$I_F = 16\text{ mA}$, $V_O = 0.5\text{ V}$, $V_{CC} = 4.5\text{ V}$	CTR	15	-	-	%

SWITCHING CHARACTERISTICS ($T_{amb} = 25\text{ }^{\circ}\text{C}$ unless otherwise specified)						
PARAMETER	TEST CONDITION	SYMBOL	MIN.	TYP.	MAX.	UNIT
Propagation delay time (high to low)	$I_F = 16\text{ mA}$, $V_{CC} = 5.0\text{ V}$, $R_L = 1.9\text{ k}\Omega$	t_{PHL}	-	0.3	0.8	μs
Propagation delay time (low to low)	$I_F = 16\text{ mA}$, $V_{CC} = 5.0\text{ V}$, $R_L = 1.9\text{ k}\Omega$	t_{PLH}	-	0.3	0.8	μs



isfh636_03

Fig. 3 - Common Mode Transient Test



isfh636_04

Fig. 4 - Measurement Waveform of CMR

COMMON MODE TRANSIENT IMMUNITY ($T_{amb} = 25\text{ }^{\circ}\text{C}$ unless otherwise specified)						
PARAMETER	TEST CONDITION	SYMBOL	MIN.	TYP.	MAX.	UNIT
Common mode transient immunity (high)	$I_O = 0\text{ mA}$, $V_{CM} = 1500\text{ V}_{P-P}$, $R_L = 1.9\text{ k}\Omega$, $V_{CC} = 5.0\text{ V}$	$ CM_H $	-	10 000	-	$\text{V}/\mu\text{s}$
Common mode transient immunity (low)	$I_O = 16\text{ mA}$, $V_{CM} = 1500\text{ V}_{P-P}$, $R_L = 1.9\text{ k}\Omega$, $V_{CC} = 5.0\text{ V}$	$ CM_L $	-	10 000	-	$\text{V}/\mu\text{s}$

SAFETY AND INSULATION RATINGS				
PARAMETER	TEST CONDITION	SYMBOL	VALUE	UNIT
Climatic classification	According to IEC 68 part 1		55/100/21	
Pollution degree	According to DIN VDE 0109		2	
Comparative tracking index	Insulation group IIIa	CTI	175	
Maximum rated withstanding isolation voltage	According to UL1577, t = 1 min	V_{ISO}	4420	V_{RMS}
Tested withstanding isolation voltage	According to UL1577, t = 1 s	V_{ISO}	5300	V_{RMS}
Maximum transient isolation voltage	According to DIN EN 60747-5-5	V_{IOTM}	8000	V_{peak}
Maximum repetitive peak isolation voltage	According to DIN EN 60747-5-5	V_{IORM}	890	V_{peak}
Isolation resistance	$T_{amb} = 25\text{ }^{\circ}\text{C}$, $V_{IO} = 500\text{ V}$	R_{IO}	$\geq 10^{12}$	Ω
	$T_{amb} = 100\text{ }^{\circ}\text{C}$, $V_{IO} = 500\text{ V}$	R_{IO}	$\geq 10^{11}$	Ω
Output safety power		P_{SO}	700	mW
Input safety current		I_{SI}	400	mA
Input safety temperature		T_S	175	$^{\circ}\text{C}$
Creepage distance	DIP-6		≥ 7	mm
Clearance distance	DIP-6		≥ 7	mm
Creepage distance	DIP-6, option 6		≥ 8	mm
Clearance distance	DIP-6, option 6		≥ 8	mm
Creepage distance	SMD-6, option 7		≥ 7	mm
Clearance distance	SMD-6, option 7		≥ 7	mm
Creepage distance	SMD-6, option 9		≥ 7	mm
Clearance distance	SMD-6, option 9		≥ 7	mm
Insulation thickness		DTI	≥ 0.4	mm

Note

- As per IEC 60747-5-5, § 7.4.3.8.2, this optocoupler is suitable for “safe electrical insulation” only within the safety ratings. Compliance with the safety ratings shall be ensured by means of protective circuits.

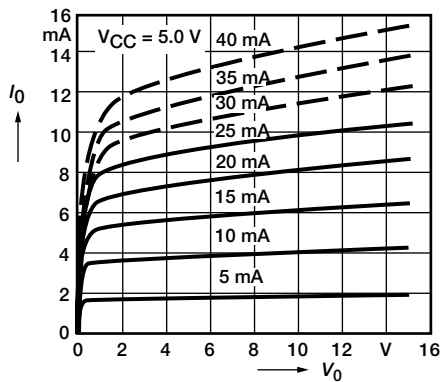
TYPICAL CHARACTERISTICS ($T_{amb} = 25\text{ }^{\circ}\text{C}$, unless otherwise specified)


Fig. 5 - Output Characteristics-Output Current vs. Output Voltage

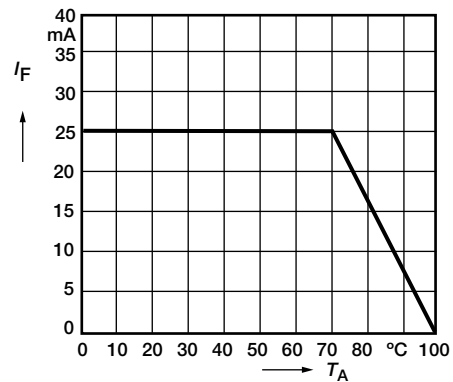


Fig. 6 - Permissible Forward Current of Emitting Diode vs. Ambient Temperature

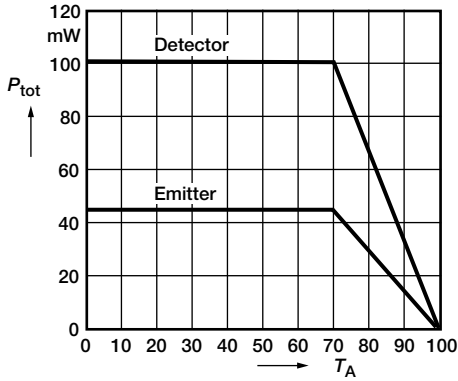


Fig. 7 - Permissible Total Power Dissipation vs. Ambient Temperature

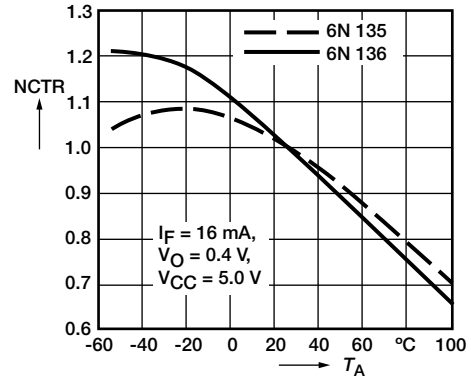


Fig. 10 - Current Transfer Ratio (Normalized) vs. Ambient Temperature

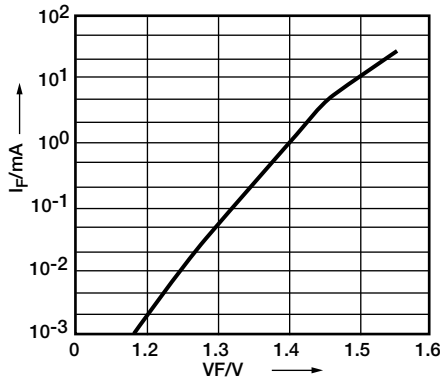


Fig. 8 - Forward Current of Emitting Diode vs. Forward Voltage

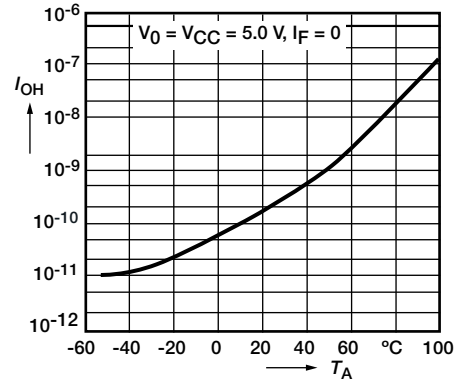


Fig. 11 - Output Current (High) vs. Ambient Temperature

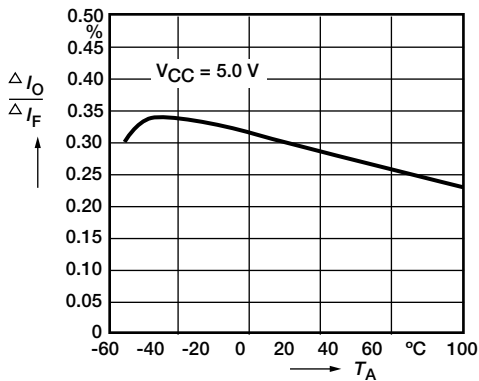


Fig. 9 - Small Signal Transfer Ratio vs. Forward Current

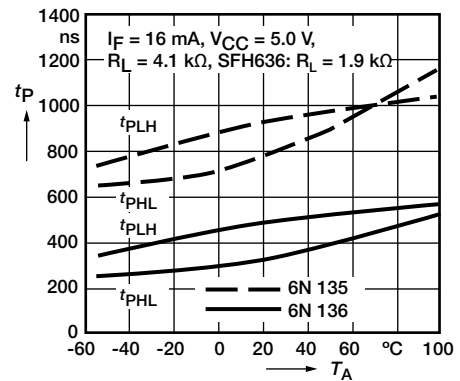


Fig. 12 - Delay Times vs. Ambient Temperature

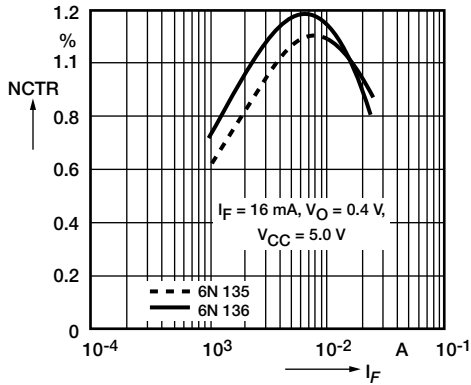
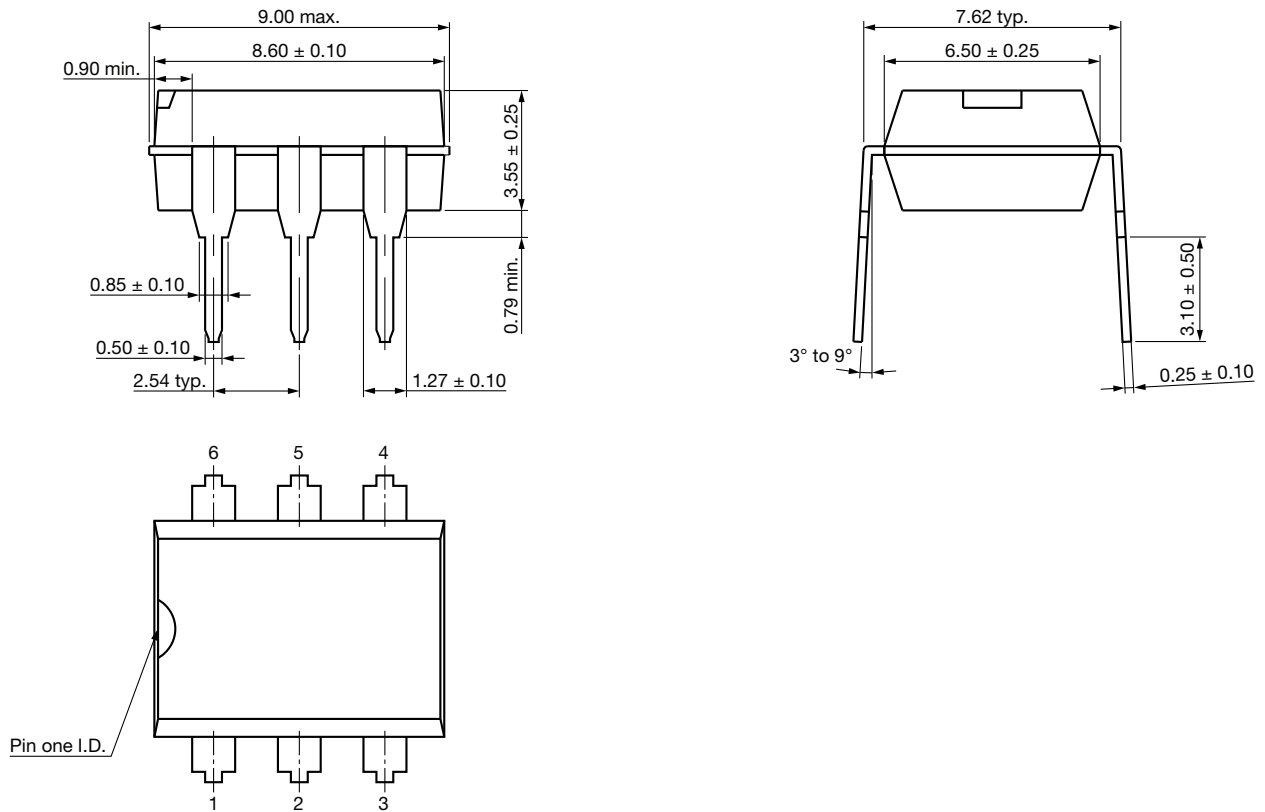


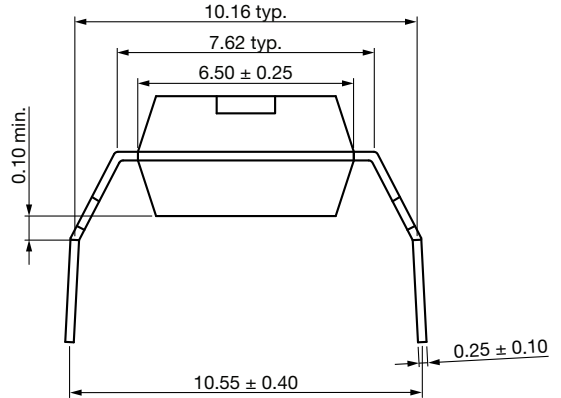
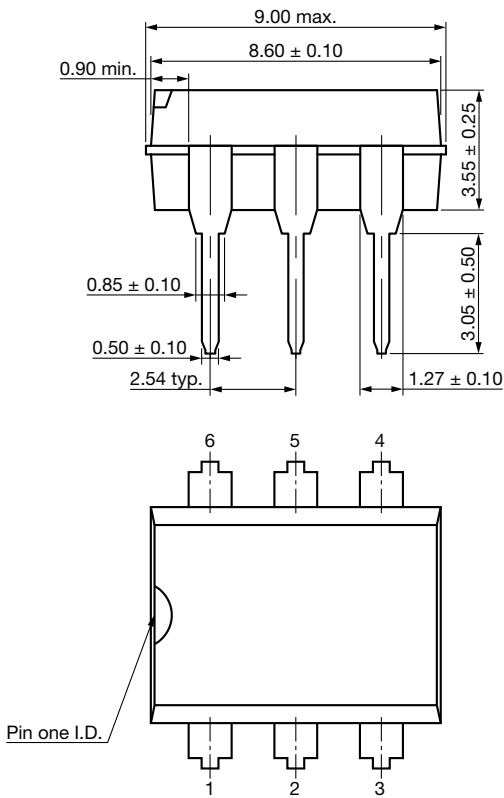
Fig. 13 - Current Transfer Ratio (Normalized) vs. Forward Current

PACKAGE DIMENSIONS in inches (millimeters)

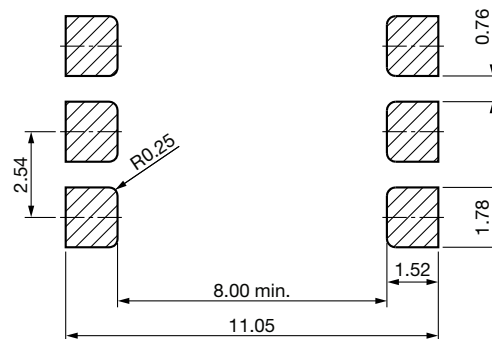
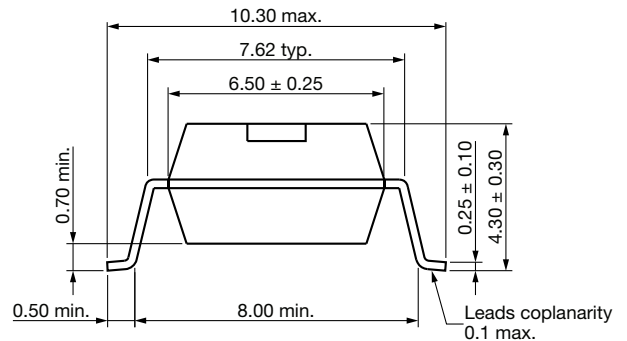
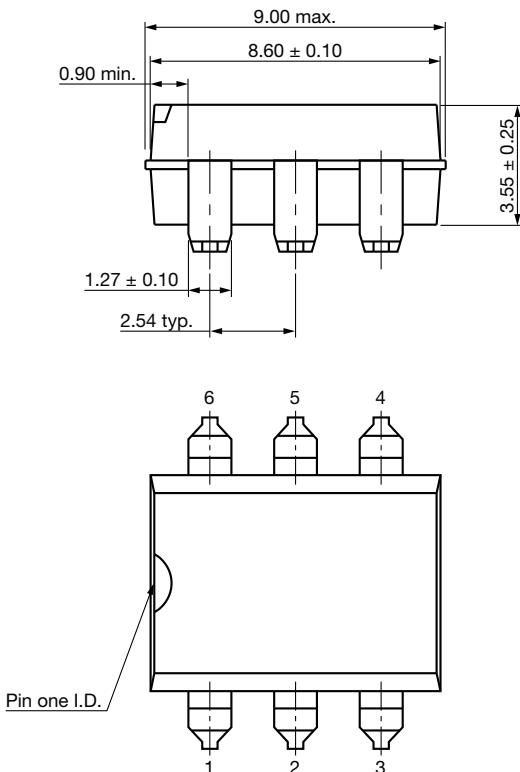
DIP-6



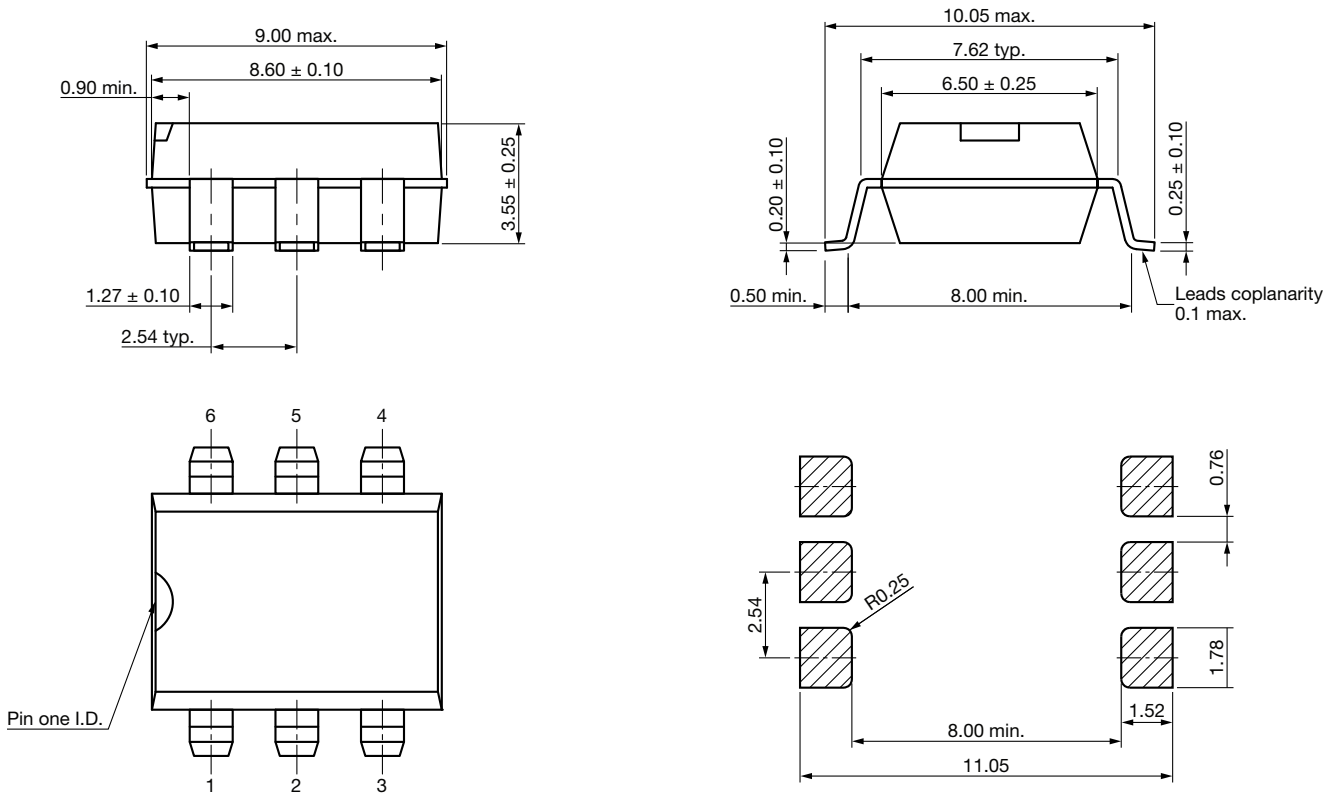
DIP-6, Option 6



SMD-6, Option 7



SMD-6, Option 9



SOLDER PROFILES

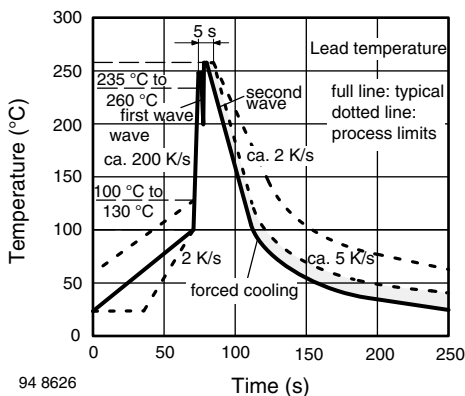


Fig. 14 - Wave Soldering Double Wave Profile According to J-STD-020 for DIP Devices

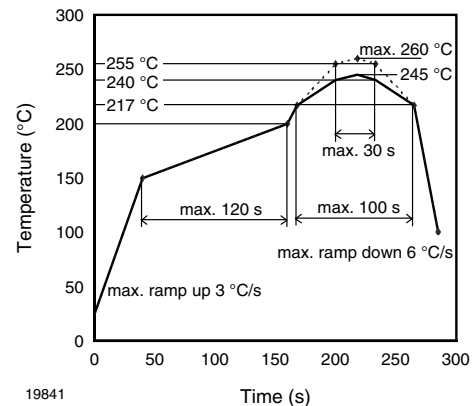


Fig. 15 - Lead (Pb)-free Reflow Solder Profile According to J-STD-020 for SMD Devices

HANDLING AND STORAGE CONDITIONS

- ESD level: HBM class 2
- Floor life: unlimited
- Conditions: $T_{amb} < 30\text{ }^{\circ}\text{C}$, RH < 85 %
- Moisture sensitivity level 1, according to J-STD-020



Disclaimer

ALL PRODUCT, PRODUCT SPECIFICATIONS AND DATA ARE SUBJECT TO CHANGE WITHOUT NOTICE TO IMPROVE RELIABILITY, FUNCTION OR DESIGN OR OTHERWISE.

Vishay Intertechnology, Inc., its affiliates, agents, and employees, and all persons acting on its or their behalf (collectively, "Vishay"), disclaim any and all liability for any errors, inaccuracies or incompleteness contained in any datasheet or in any other disclosure relating to any product.

Vishay makes no warranty, representation or guarantee regarding the suitability of the products for any particular purpose or the continuing production of any product. To the maximum extent permitted by applicable law, Vishay disclaims (i) any and all liability arising out of the application or use of any product, (ii) any and all liability, including without limitation special, consequential or incidental damages, and (iii) any and all implied warranties, including warranties of fitness for particular purpose, non-infringement and merchantability.

Statements regarding the suitability of products for certain types of applications are based on Vishay's knowledge of typical requirements that are often placed on Vishay products in generic applications. Such statements are not binding statements about the suitability of products for a particular application. It is the customer's responsibility to validate that a particular product with the properties described in the product specification is suitable for use in a particular application. Parameters provided in datasheets and / or specifications may vary in different applications and performance may vary over time. All operating parameters, including typical parameters, must be validated for each customer application by the customer's technical experts. Product specifications do not expand or otherwise modify Vishay's terms and conditions of purchase, including but not limited to the warranty expressed therein.

Except as expressly indicated in writing, Vishay products are not designed for use in medical, life-saving, or life-sustaining applications or for any other application in which the failure of the Vishay product could result in personal injury or death. Customers using or selling Vishay products not expressly indicated for use in such applications do so at their own risk. Please contact authorized Vishay personnel to obtain written terms and conditions regarding products designed for such applications.

No license, express or implied, by estoppel or otherwise, to any intellectual property rights is granted by this document or by any conduct of Vishay. Product names and markings noted herein may be trademarks of their respective owners.