

## Half Bridge IGBT Power Module, 1200 V, 100 A

**INT-A-PAK**

### FEATURES

- Low  $V_{CE(sat)}$  trench IGBT technology
- 10  $\mu$ s short circuit capability
- $V_{CE(sat)}$  with positive temperature coefficient
- Maximum junction temperature 175 °C
- Low inductance case
- Fast and soft reverse recovery antiparallel FWD
- Isolated copper baseplate using DCB (Direct Copper Bonding) technology
- Material categorization: for definitions of compliance please see [www.vishay.com/doc?99912](http://www.vishay.com/doc?99912)

**RoHS**  
COMPLIANT

PRODUCT SUMMARY	
$V_{CES}$	1200 V
$I_C$ at $T_C = 80$ °C	100 A
$V_{CE(on)}$ (typical) at $I_C = 100$ A, 25 °C	1.90 V
Speed	8 kHz to 30 kHz
Package	INT-A-PAK
Circuit	Half bridge

### TYPICAL APPLICATIONS

- UPS (Uninterruptable Power Supply)
- Inverter for motor drive
- AC and DC servo drive amplifier

### DESCRIPTION

Vishay's IGBT power module provides ultra low conduction loss as well as short circuit ruggedness. It is designed for applications such as general inverters and UPS.

ABSOLUTE MAXIMUM RATINGS ( $T_C = 25$ °C unless otherwise noted)				
PARAMETER	SYMBOL	TEST CONDITIONS	MAX.	UNITS
Collector to emitter voltage	$V_{CES}$		1200	V
Gate to emitter voltage	$V_{GES}$		$\pm 30$	
Collector current	$I_C$	$T_C = 25$ °C	180	A
		$T_C = 80$ °C	100	
Pulsed collector current	$I_{CM}^{(1)}$	$t_p = 1$ ms	200	
Diode continuous forward current	$I_F$	$T_C = 80$ °C	100	
Diode maximum forward current	$I_{FM}^{(1)}$	$t_p = 1$ ms	200	
Maximum power dissipation	$P_D$	$T_J = 175$ °C	652	
Short circuit withstand time	$t_{SC}$	$T_C = 125$ °C	10	$\mu$ s
RMS isolation voltage	$V_{ISOL}$	$f = 50$ Hz, $t = 1$ min	4000	V

**Note**

(1) Repetitive rating: pulse width limited by maximum junction temperature.

IGBT ELECTRICAL SPECIFICATIONS ( $T_C = 25$ °C unless otherwise noted)						
PARAMETER	SYMBOL	TEST CONDITIONS	MIN.	TYP.	MAX.	UNITS
Collector to emitter breakdown voltage	$V_{(BR)CES}$	$T_J = 25$ °C	1200	-	-	V
Collector to emitter saturation voltage	$V_{CE(sat)}$	$V_{GE} = 15$ V, $I_C = 100$ A, $T_J = 25$ °C	-	1.90	2.35	
		$V_{GE} = 15$ V, $I_C = 100$ A, $T_J = 175$ °C	-	2.50	-	
Gate to emitter threshold voltage	$V_{GE(th)}$	$V_{CE} = V_{GE}$ , $I_C = 5.0$ mA, $T_J = 25$ °C	5.0	5.9	7.5	
Collector cut-off current	$I_{CES}$	$V_{CE} = V_{CES}$ , $V_{GE} = 0$ V, $T_J = 25$ °C	-	-	5.0	mA
Gate to emitter leakage current	$I_{GES}$	$V_{GE} = V_{GES}$ , $V_{CE} = 0$ V, $T_J = 25$ °C	-	-	400	nA



SWITCHING CHARACTERISTICS						
PARAMETER	SYMBOL	TEST CONDITIONS	MIN.	TYP.	MAX.	UNITS
Turn-on delay time	$t_{d(on)}$	$V_{CC} = 600\text{ V}, I_C = 100\text{ A}, R_g = 5.6\ \Omega, V_{GE} = \pm 15\text{ V}, T_J = 25\text{ }^\circ\text{C}$	-	187	-	ns
Rise time	$t_r$		-	57	-	
Turn-off delay time	$t_{d(off)}$		-	180	-	
Fall time	$t_f$		-	149	-	
Turn-on switching loss	$E_{on}$		-	4.97	-	mJ
Turn-off switching loss	$E_{off}$		-	4.69	-	
Turn-on delay time	$t_{d(on)}$	$V_{CC} = 600\text{ V}, I_C = 100\text{ A}, R_g = 5.6\ \Omega, V_{GE} = \pm 15\text{ V}, T_J = 125\text{ }^\circ\text{C}$	-	189	-	ns
Rise time	$t_r$		-	58	-	
Turn-off delay time	$t_{d(off)}$		-	187	-	
Fall time	$t_f$		-	220	-	
Turn-on switching loss	$E_{on}$		-	7.80	-	mJ
Turn-off switching loss	$E_{off}$		-	5.85	-	
Input capacitance	$C_{ies}$	$V_{GE} = 0\text{ V}, V_{CE} = 30\text{ V}, f = 1.0\text{ MHz}$	-	12.8	-	nF
Output capacitance	$C_{oes}$		-	0.46	-	
Reverse transfer capacitance	$C_{res}$		-	0.32	-	
SC data	$I_{SC}$	$t_p \leq 10\ \mu\text{s}, V_{GE} = 15\text{ V}, T_J = 125\text{ }^\circ\text{C}, V_{CC} = 900\text{ V}, V_{CEM} \leq 1200\text{ V}$	-	890	-	A
Stray inductance	$L_{CE}$		-	-	30	nH
Module lead resistance, terminal to chip	$R_{CC'+EE'}$		-	0.75	-	m $\Omega$

DIODE ELECTRICAL SPECIFICATIONS ( $T_C = 25\text{ }^\circ\text{C}$ unless otherwise noted)							
PARAMETER	SYMBOL	TEST CONDITIONS	MIN.	TYP.	MAX.	UNITS	
Forward voltage	$V_F$	$I_F = 100\text{ A}$	$T_J = 25\text{ }^\circ\text{C}$	-	1.82	2.20	V
			$T_J = 125\text{ }^\circ\text{C}$	-	1.95	-	
Reverse recovery charge	$Q_{rr}$	$I_F = 100\text{ A}, V_R = 600\text{ V}, R_G = 5.6\ \Omega, V_{GE} = -15\text{ V}$	$T_J = 25\text{ }^\circ\text{C}$	-	8.1	-	$\mu\text{C}$
			$T_J = 125\text{ }^\circ\text{C}$	-	14.0	-	
Peak reverse recovery current	$I_{rr}$	$I_F = 100\text{ A}, V_R = 600\text{ V}, R_G = 5.6\ \Omega, V_{GE} = -15\text{ V}$	$T_J = 25\text{ }^\circ\text{C}$	-	81	-	A
			$T_J = 125\text{ }^\circ\text{C}$	-	98	-	
Reverse recovery energy	$E_{rec}$	$I_F = 100\text{ A}, V_R = 600\text{ V}, R_G = 5.6\ \Omega, V_{GE} = -15\text{ V}$	$T_J = 25\text{ }^\circ\text{C}$	-	2.99	-	mJ
			$T_J = 125\text{ }^\circ\text{C}$	-	4.85	-	

THERMAL AND MECHANICAL SPECIFICATIONS						
PARAMETER	SYMBOL	TEST CONDITIONS	MIN.	TYP.	MAX.	UNITS
Maximum junction temperature	$T_J$		-	-	175	$^\circ\text{C}$
Storage temperature range	$T_{Stg}$		-40	-	125	$^\circ\text{C}$
Junction to case per 1/2 module	$R_{thJC}$	IGBT	-	-	0.23	K/W
		Diode	-	-	0.36	
Case to sink (Conductive grease applied)	$R_{thCS}$		-	0.05	-	
Mounting torque		Power terminal screw: M5	2.5 to 5.0			Nm
		Mounting screw: M6	3.0 to 5.0			
Weight		Weight of module	-	150	-	g

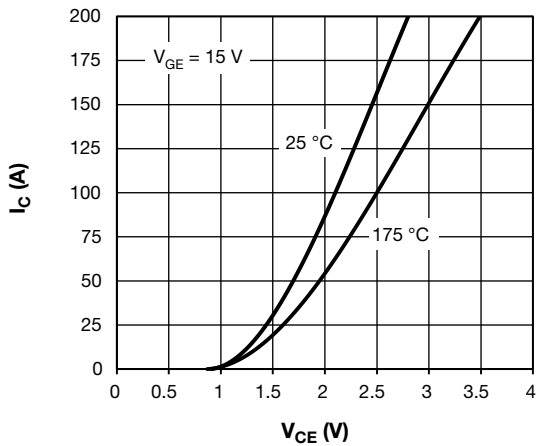

Fig. 1 - IGBT Typical Output Characteristics

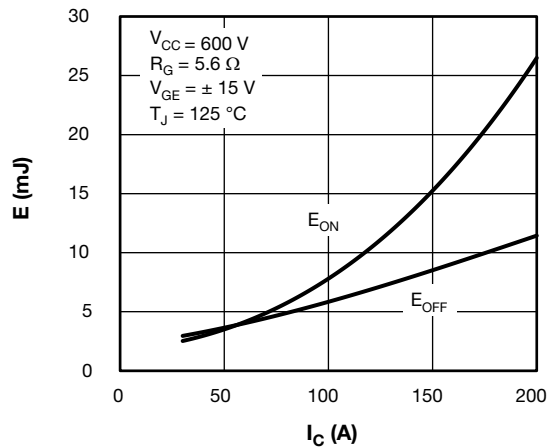

Fig. 3 - IGBT Switching Loss vs.  $I_C$

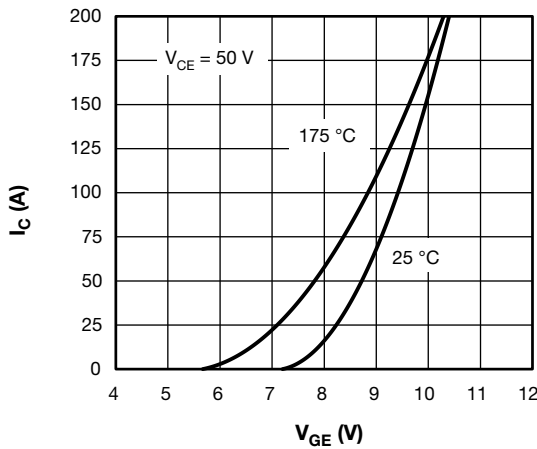

Fig. 2 - IGBT Transfer Characteristics

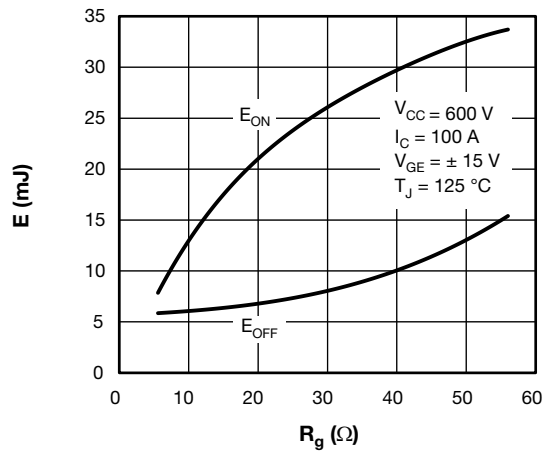

Fig. 4 - IGBT Switching Loss vs.  $R_G$

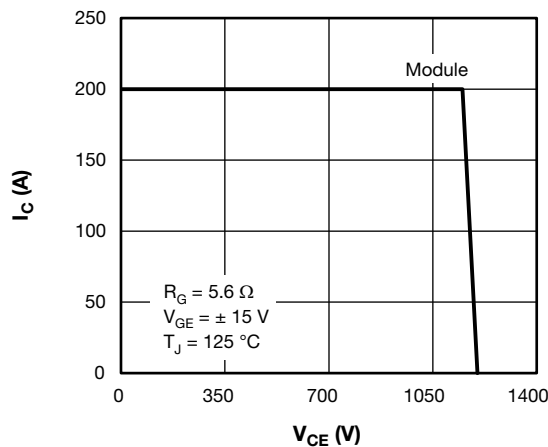

Fig. 5 - RBSOA

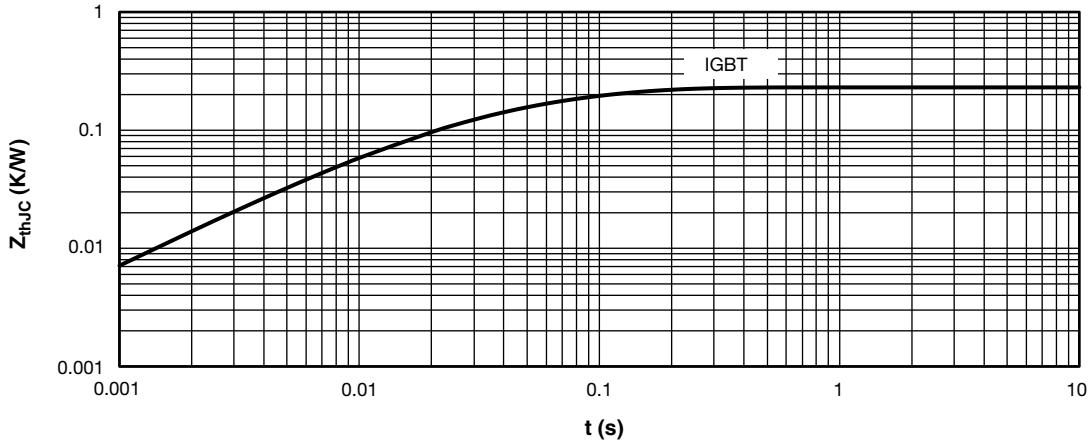

Fig. 6 - IGBT Transient Thermal Impedance

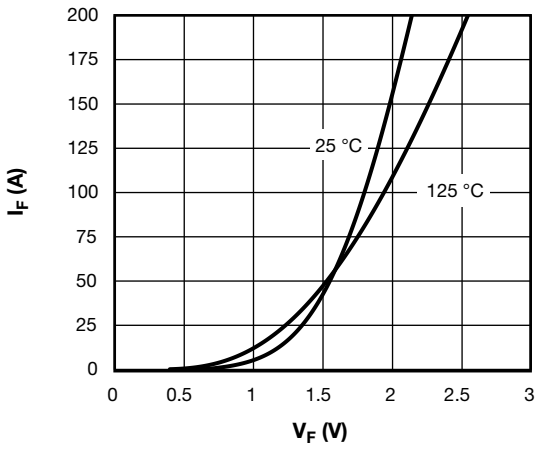

Fig. 7 - Diode Forward Characteristics

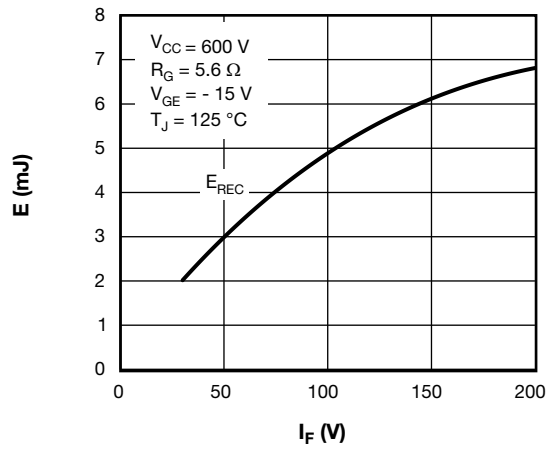

Fig. 8 - Diode Switching Loss vs.  $I_F$

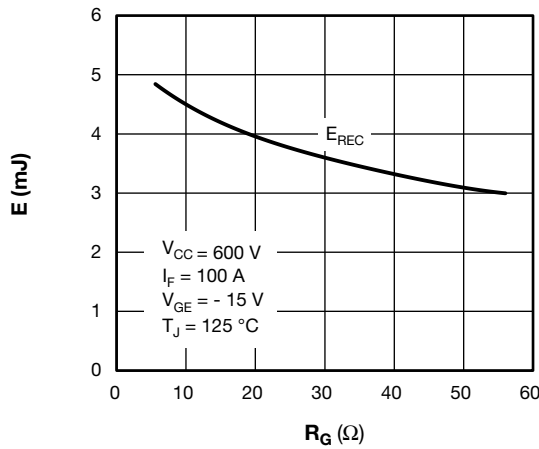

Fig. 9 - Diode Switching Loss vs.  $R_G$

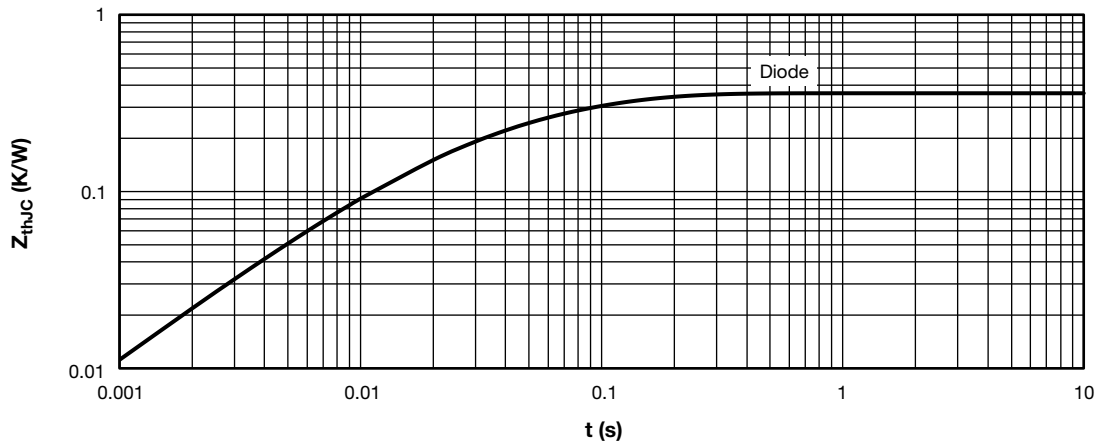
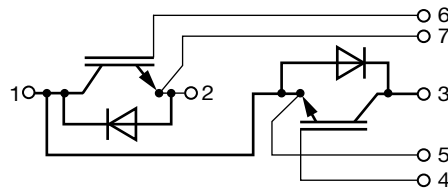

Fig. 10 - Diode Transient Thermal Impedance

**CIRCUIT CONFIGURATION**



LINKS TO RELATED DOCUMENTS	
Dimensions	<a href="http://www.vishay.com/doc?95524">www.vishay.com/doc?95524</a>



## INT-A-PAK

**DIMENSIONS** in millimeters (inches)

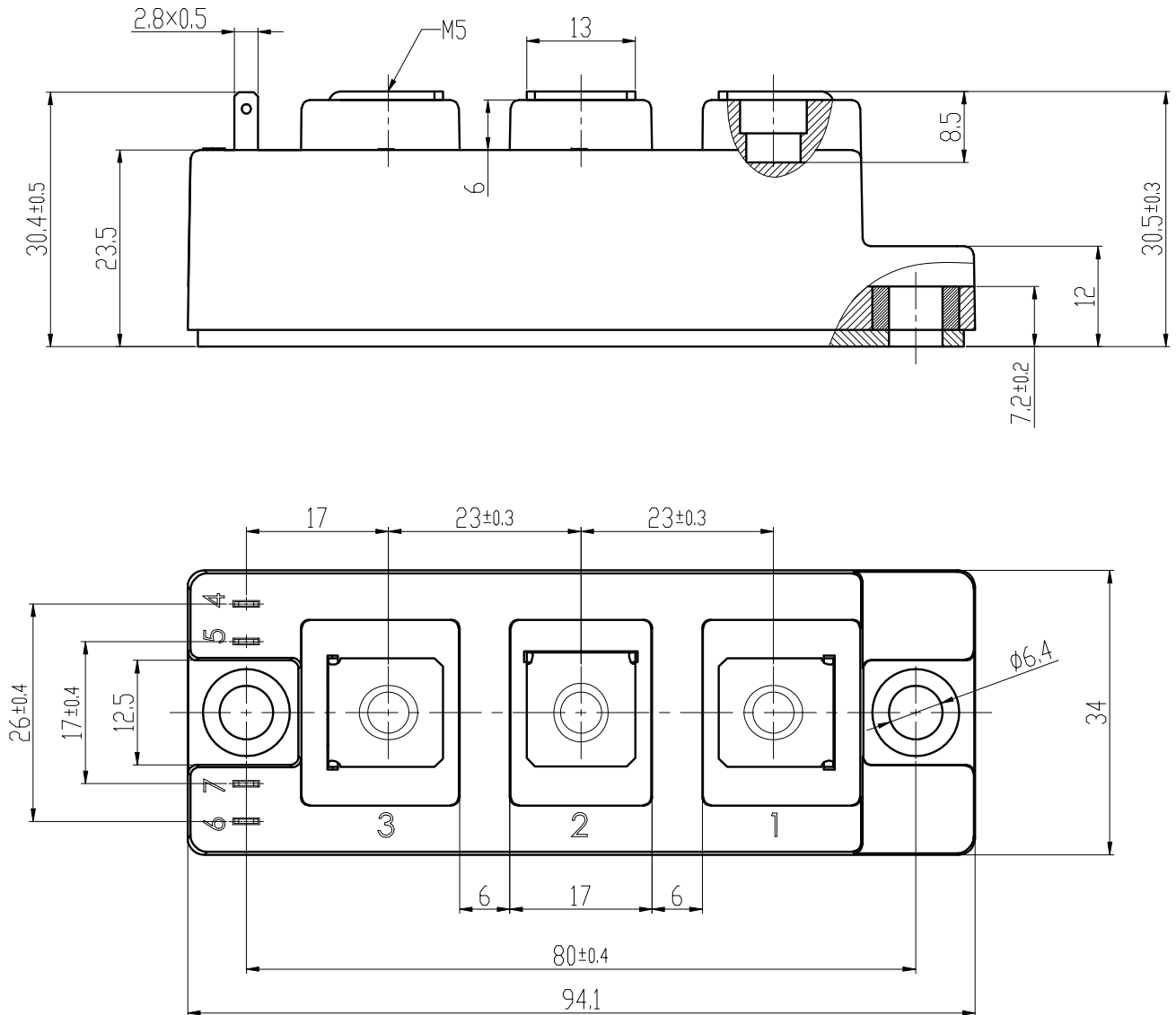



## Disclaimer

ALL PRODUCT, PRODUCT SPECIFICATIONS AND DATA ARE SUBJECT TO CHANGE WITHOUT NOTICE TO IMPROVE RELIABILITY, FUNCTION OR DESIGN OR OTHERWISE.

Vishay Intertechnology, Inc., its affiliates, agents, and employees, and all persons acting on its or their behalf (collectively, "Vishay"), disclaim any and all liability for any errors, inaccuracies or incompleteness contained in any datasheet or in any other disclosure relating to any product.

Vishay makes no warranty, representation or guarantee regarding the suitability of the products for any particular purpose or the continuing production of any product. To the maximum extent permitted by applicable law, Vishay disclaims (i) any and all liability arising out of the application or use of any product, (ii) any and all liability, including without limitation special, consequential or incidental damages, and (iii) any and all implied warranties, including warranties of fitness for particular purpose, non-infringement and merchantability.

Statements regarding the suitability of products for certain types of applications are based on Vishay's knowledge of typical requirements that are often placed on Vishay products in generic applications. Such statements are not binding statements about the suitability of products for a particular application. It is the customer's responsibility to validate that a particular product with the properties described in the product specification is suitable for use in a particular application. Parameters provided in datasheets and/or specifications may vary in different applications and performance may vary over time. All operating parameters, including typical parameters, must be validated for each customer application by the customer's technical experts. Product specifications do not expand or otherwise modify Vishay's terms and conditions of purchase, including but not limited to the warranty expressed therein.

Except as expressly indicated in writing, Vishay products are not designed for use in medical, life-saving, or life-sustaining applications or for any other application in which the failure of the Vishay product could result in personal injury or death. Customers using or selling Vishay products not expressly indicated for use in such applications do so at their own risk. Please contact authorized Vishay personnel to obtain written terms and conditions regarding products designed for such applications.

No license, express or implied, by estoppel or otherwise, to any intellectual property rights is granted by this document or by any conduct of Vishay. Product names and markings noted herein may be trademarks of their respective owners.

## Material Category Policy

**Vishay Intertechnology, Inc. hereby certifies that all its products that are identified as RoHS-Compliant fulfill the definitions and restrictions defined under Directive 2011/65/EU of The European Parliament and of the Council of June 8, 2011 on the restriction of the use of certain hazardous substances in electrical and electronic equipment (EEE) - recast, unless otherwise specified as non-compliant.**

**Please note that some Vishay documentation may still make reference to RoHS Directive 2002/95/EC. We confirm that all the products identified as being compliant to Directive 2002/95/EC conform to Directive 2011/65/EU.**

**Vishay Intertechnology, Inc. hereby certifies that all its products that are identified as Halogen-Free follow Halogen-Free requirements as per JEDEC JS709A standards. Please note that some Vishay documentation may still make reference to the IEC 61249-2-21 definition. We confirm that all the products identified as being compliant to IEC 61249-2-21 conform to JEDEC JS709A standards.**