

Ceramic Disc Capacitors Class 1, 4 kV_{DC}

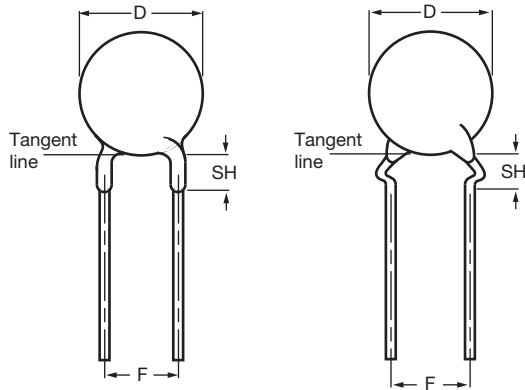

Capacitors with 7.5 mm (0.30") and 10 mm (0.40") lead spacing

| QUICK REFERENCE DATA | |
|----------------------------|---------------|
| DESCRIPTION | CLASS 1 (C0G) |
| Voltage (V _{DC}) | 4000 |
| Min. Capacitance (pF) | 2 |
| Max. Capacitance (pF) | 100 |
| Mounting | Through hole |

MARKING

Straight and kinked leaded versions are gold colored. Marking indicates capacitance value and tolerance in accordance with "EIA 198", and voltage.

OPERATING TEMPERATURE RANGE

Class 1, C0G; U2J, U2M, - 55 °C to + 125 °C

TEMPERATURE COEFFICIENTS

Class 1, C0G

SECTIONAL SPECIFICATIONS

Class 1, C0G, IEC 60384-8,
EIA 198

CLIMATIC CATEGORY

Class 1, C0G; U2J, U2M 55/125/21

FEATURES

- Low losses
- High stability
- High capacitance in small size
- Kinked (preferred) or straight leads
- Compliant of RoHS directive 2002/95/EC



RoHS
COMPLIANT

APPLICATIONS

- DC high voltage
- Pulse high voltage
- LCD backlight inverter

DESIGN

The capacitors consist of a ceramic disc both sides of which are silver-plated. Connection leads are made of tinned copper having a diameter of 0.6 mm or 0.8 mm.

The capacitors may be supplied with kinked or straight leads with a lead spacing of 7.5 mm (0.30") or 10 mm (0.40") and a lead length from 4 mm to 30 mm. The standard tolerance on capacitance is $\pm 5\%$ or $\pm 10\%$ for class 1 capacitors. Encapsulation is made of gold-colored epoxy-resin, flammable resistant in accordance with "UL 94 V-0".

CAPACITANCE RANGE

Class 1, at 1 MHz, 1.2 V_{RMS}; 2 pF to 100 pF

RATED DC VOLTAGE

4 kV

DIELECTRIC STRENGTH

According to IEC 384-8, $1.5 \times U_R + 500 V_{DC}$ (6.5 kV_{DC})

INSULATION RESISTANCE AT 500 V_{DC}

$\geq 10\,000 M\Omega$

TOLERANCE ON CAPACITANCE

$\pm 5\%$; $\pm 10\%$

Other tolerances available on request

DISSIPATION FACTOR

$C \leq 5\text{ pF}$, 0.55 % max.;

$10\text{ pF} \leq C < 33\text{ pF}$, $20 \times (150/C + 7) \times 10^{-4}$;

$C \geq 33\text{ pF}$, 0.20 % max.

| ORDERING INFORMATION, 4 kV _{DC} , KINKED | | | | | |
|---|-------------|---------------------------|---------------------------|---------------------------|---|
| C (pF) | TOL. (%) | D _{MAX.} (mm) | LEAD SPACING F (mm) | SH ⁽¹⁾ (mm) | CLEAR TEXT CODE |
| | | | | | 13TH DIGIT: T = REEL; U = AMMO; 3 = BULK |
| CLASS 1 COG | | | | | |
| 2 | ± 0.5 | 6.5 | 7.5 | 4.0 | S209D25C0KV6.K7R |
| 3 | | | | | S309D25C0JV6.K7R |
| 5 | | 7.5 | | | S509D29C0HV6.K7R |
| 10 | ± 5 | 6.5 | | | S100J25U2JV6.K7R |
| 12 | | 7.5 | | | S120J29U2JV6.K7R |
| 15 | | | | | S150J29U2JV6.K7R |
| 18 | | | | | S180J25U2MV6.K7R |
| 22 | | | | | S220J25U2MV6.K7R |
| 27 | | | | | S270J25U2MV6.K7R |
| 33 | | | | | S330J29U2MV6.K7R |
| 39 | | S390J29U2MV6.K7R | | | |
| 47 | | 8.0 | S470J31U2MV6.K7R | | |
| 68 | | 9.0 | S680J35U2MV6.K7R | | |
| 100 | | 10.0 | S101J39U2MV6.K7R | | |

Notes

- (1) SH = Seated height
- Maximum thickness 5.0 mm
- Refer to outward kinked leads. Other styles available on request (straight or inline kinked leads).

| PACKAGING | | | | | |
|---------------------------------|-----------|--------------------|-------------------------------|------|-------------------------------------|
| PACKAGING TYPE | SIZE CODE | LEAD SPACE (mm) | VOLTAGE (V _{DC}) | SPQ | BOX DIMENSIONS L x W x H (mm) |
| Bulk (long lead L ≥ 25.4 mm) | 25 to 47 | 10.0 | 4 kV | 1000 | 245 x 120 x 65 |
| | | | | 1000 | |
| | 1000 | | | | |
| | 500 | | | | |

Note

- The capacitors are supplied in bulk packaging (cardboard boxes), in tape on reel or in ammopack

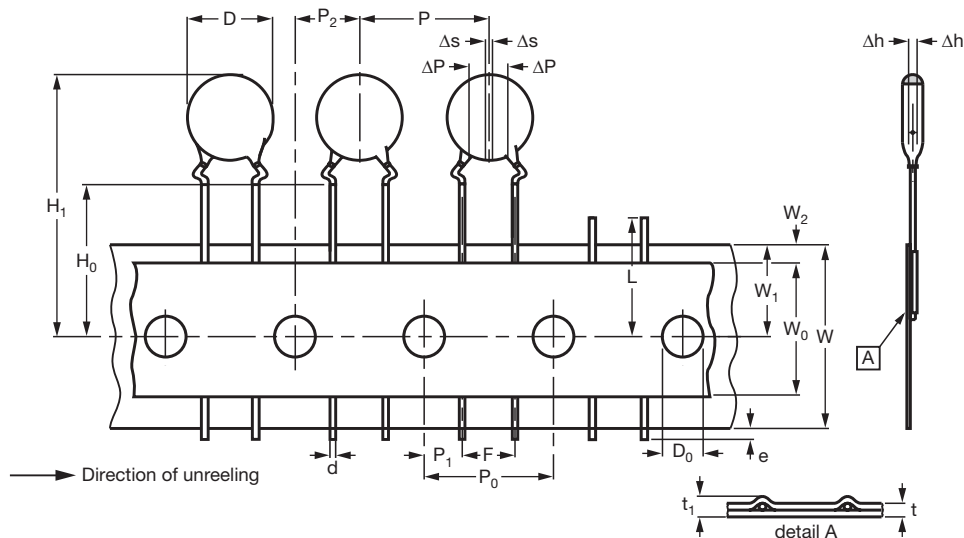

Kinked capacitors on tape, lead spacing 7.5 mm (0.30")

| DIMENSIONS OF TAPE | | | |
|-------------------------------|--------------------------------------|-----------------|---------------|
| SYMBOL | PARAMETER | DIMENSIONS (mm) | |
| | | NOMINAL | TOLERANCE |
| D | Body diameter | 14.0 max. | - |
| d | Lead diameter | 0.6 | ± 0.05 |
| P | Pitch between capacitors | 15 | ± 1.0 |
| P ₀ ⁽¹⁾ | Feed-hole pitch | 15 | ± 0.3 |
| ΔP | Plane deviation | 1.0 max. | - |
| P ₁ ⁽²⁾ | Feed-hole center to lead center | 3.75 | ± 0.7 |
| P ₂ ⁽²⁾ | Feed-hole center to component center | 7.5 | ± 1.3 |
| F | Lead spacing | 7.5 | + 0.6/- 0.4 |
| Δh | Component alignment | 0 | ± 1.0 |
| W | Tape width | 18.0 | 1.0 - 0.5 |
| W ₀ | Hold-down tape width | 5.0 min. | - |
| W ₁ | Hole position | 9.0 | 0.75 - 0.5 |
| W ₂ | Hold-down tape margin | 3.0 max. | - |
| H ₀ | Height to seating plane | 16.0 | ± 0.5 |
| H ₁ | Maximum component height | 40.0 | - |
| e | Lead end protrusion | 1.0 max. | - |
| L | Maximum length of snipped lead | 11.0 | - |
| D ₀ | Feed-hole diameter | 4.0 | ± 0.2 |
| t | Total tape thickness | 0.9 max. | - |
| t ₁ | Maximum thickness of tape and wires | 1.5 max. | - |

Notes

(1) Cumulative pitch error: $\pm \leq 1$ mm/20 pitches

(2) Obliquity maximum 3°

REEL AND TAPE DATA in millimeters

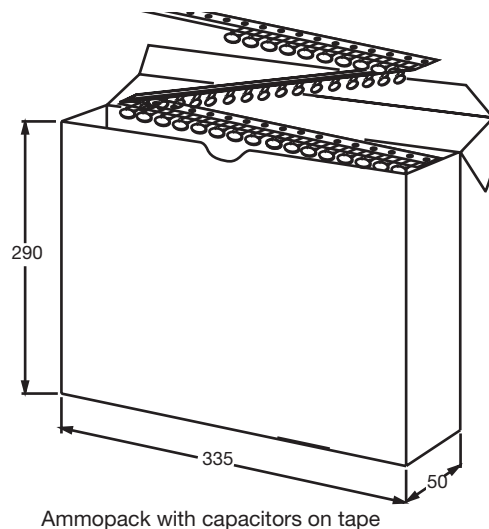
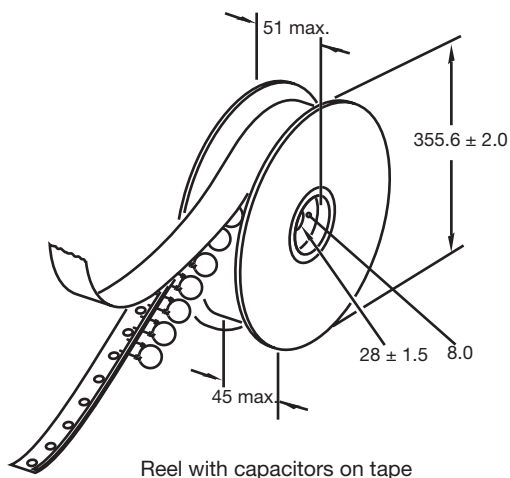



Disclaimer

ALL PRODUCT, PRODUCT SPECIFICATIONS AND DATA ARE SUBJECT TO CHANGE WITHOUT NOTICE TO IMPROVE RELIABILITY, FUNCTION OR DESIGN OR OTHERWISE.

Vishay Intertechnology, Inc., its affiliates, agents, and employees, and all persons acting on its or their behalf (collectively, "Vishay"), disclaim any and all liability for any errors, inaccuracies or incompleteness contained in any datasheet or in any other disclosure relating to any product.

Vishay makes no warranty, representation or guarantee regarding the suitability of the products for any particular purpose or the continuing production of any product. To the maximum extent permitted by applicable law, Vishay disclaims (i) any and all liability arising out of the application or use of any product, (ii) any and all liability, including without limitation special, consequential or incidental damages, and (iii) any and all implied warranties, including warranties of fitness for particular purpose, non-infringement and merchantability.

Statements regarding the suitability of products for certain types of applications are based on Vishay's knowledge of typical requirements that are often placed on Vishay products in generic applications. Such statements are not binding statements about the suitability of products for a particular application. It is the customer's responsibility to validate that a particular product with the properties described in the product specification is suitable for use in a particular application. Parameters provided in datasheets and / or specifications may vary in different applications and performance may vary over time. All operating parameters, including typical parameters, must be validated for each customer application by the customer's technical experts. Product specifications do not expand or otherwise modify Vishay's terms and conditions of purchase, including but not limited to the warranty expressed therein.

Hyperlinks included in this datasheet may direct users to third-party websites. These links are provided as a convenience and for informational purposes only. Inclusion of these hyperlinks does not constitute an endorsement or an approval by Vishay of any of the products, services or opinions of the corporation, organization or individual associated with the third-party website. Vishay disclaims any and all liability and bears no responsibility for the accuracy, legality or content of the third-party website or for that of subsequent links.

Except as expressly indicated in writing, Vishay products are not designed for use in medical, life-saving, or life-sustaining applications or for any other application in which the failure of the Vishay product could result in personal injury or death. Customers using or selling Vishay products not expressly indicated for use in such applications do so at their own risk. Please contact authorized Vishay personnel to obtain written terms and conditions regarding products designed for such applications.

No license, express or implied, by estoppel or otherwise, to any intellectual property rights is granted by this document or by any conduct of Vishay. Product names and markings noted herein may be trademarks of their respective owners.