

TVS Diodes

Transient Voltage Suppressor Diodes

ESD3V3U1U Series

Uni-directional Ultra-low Capacitance ESD / Transient Protection Diode

ESD3V3U1U-02LS
ESD3V3U1U-02LRH

Data Sheet

Revision 1.0, 2011-04-12
Final

Industrial and Multi-Market

Edition 2011-04-12

**Published by
Infineon Technologies AG
81726 Munich, Germany**

**© 2011 Infineon Technologies AG
All Rights Reserved.**

Legal Disclaimer

The information given in this document shall in no event be regarded as a guarantee of conditions or characteristics. With respect to any examples or hints given herein, any typical values stated herein and/or any information regarding the application of the device, Infineon Technologies hereby disclaims any and all warranties and liabilities of any kind, including without limitation, warranties of non-infringement of intellectual property rights of any third party.

Information

For further information on technology, delivery terms and conditions and prices, please contact the nearest Infineon Technologies Office (www.infineon.com).

Warnings

Due to technical requirements, components may contain dangerous substances. For information on the types in question, please contact the nearest Infineon Technologies Office.

Infineon Technologies components may be used in life-support devices or systems only with the express written approval of Infineon Technologies, if a failure of such components can reasonably be expected to cause the failure of that life-support device or system or to affect the safety or effectiveness of that device or system. Life support devices or systems are intended to be implanted in the human body or to support and/or maintain and sustain and/or protect human life. If they fail, it is reasonable to assume that the health of the user or other persons may be endangered.

Revision History

Page or Item	Subjects (major changes since previous revision)
Revision 1.0, 2011-04-12	

Trademarks of Infineon Technologies AG

AURIX™, BlueMoon™, COMNEON™, C166™, CROSSAVE™, CanPAK™, CIPOS™, CoolMOS™, CoolSET™, CORECONTROL™, DAVE™, EasyPIM™, EconoBRIDGE™, EconoDUAL™, EconoPACK™, EconoPIM™, EiceDRIVER™, EUPEC™, FCOS™, HITFET™, HybridPACK™, ISOFACE™, I²RF™, IsoPACK™, MIPAQ™, ModSTACK™, my-d™, NovalithIC™, OmniTune™, OptiMOS™, ORIGA™, PROFET™, PRO-SIL™, PRIMARION™, PrimePACK™, RASIC™, ReverSave™, SatRIC™, SIEGET™, SINDRION™, SMARTi™, SmartLEWIS™, TEMPFET™, thinQ!™, TriCore™, TRENCHSTOP™, X-GOLD™, XMM™, X-PMU™, XPOSYS™.

Other Trademarks

Advance Design System™ (ADS) of Agilent Technologies, AMBA™, ARM™, MULTI-ICE™, PRIMECELL™, REALVIEW™, THUMB™ of ARM Limited, UK. AUTOSAR™ is licensed by AUTOSAR development partnership. Bluetooth™ of Bluetooth SIG Inc. CAT-iq™ of DECT Forum. COLOSSUS™, FirstGPS™ of Trimble Navigation Ltd. EMV™ of EMVCo, LLC (Visa Holdings Inc.). EPCOS™ of Epcos AG. FLEXGO™ of Microsoft Corporation. FlexRay™ is licensed by FlexRay Consortium. HYPERTERMINAL™ of Hilgraeve Incorporated. IEC™ of Commission Electrotechnique Internationale. IrDA™ of Infrared Data Association Corporation. ISO™ of INTERNATIONAL ORGANIZATION FOR STANDARDIZATION. MATLAB™ of MathWorks, Inc. MAXIM™ of Maxim Integrated Products, Inc. MICROTEC™, NUCLEUS™ of Mentor Graphics Corporation. Mifare™ of NXP. MIPI™ of MIPI Alliance, Inc. MIPS™ of MIPS Technologies, Inc., USA. muRata™ of MURATA MANUFACTURING CO., MICROWAVE OFFICE™ (MWO) of Applied Wave Research Inc., OmniVision™ of OmniVision Technologies, Inc. Openwave™ Openwave Systems Inc. RED HAT™ Red Hat, Inc. RFMD™ RF Micro Devices, Inc. SIRIUS™ of Sirius Sattelite Radio Inc. SOLARIS™ of Sun Microsystems, Inc. SPANSION™ of Spansion LLC Ltd. Symbian™ of Symbian Software Limited. TAIYO YUDEN™ of Taiyo Yuden Co. TEAKLITE™ of CEVA, Inc. TEKTRONIX™ of Tektronix Inc. TOKO™ of TOKO KABUSHIKI KAISHA TA. UNIX™ of X/Open Company Limited. VERILOG™, PALLADIUM™ of Cadence Design Systems, Inc. VLYNQ™ of Texas Instruments Incorporated. VXWORKS™, WIND RIVER™ of WIND RIVER SYSTEMS, INC. ZETEX™ of Diodes Zetex Limited.

Last Trademarks Update 2010-06-09

Table of Contents

	Table of Contents	4
	List of Figures	5
	List of Tables	6
1	Uni-directional Ultra-low Capacitance ESD / Transient Protection Diode	7
1.1	Features	7
1.2	Application Examples	7
2	Product Description	7
3	Characteristics	8
3.1	Electrical Characteristics at $T_A = 25\text{ °C}$, unless otherwise specified	8
3.2	Typical Characteristics at $T_A=25\text{°C}$, unless otherwise specified	10
4	Application Information	13
5	Ordering Information Scheme (Examples)	14
6	Package Information	15
6.1	PG-TSSLP-2-1 (mm) [3]	15
6.2	PG-TSLP-2-7 (mm)[3]	16
	Terminology	17
	References	18

List of Figures

Figure 1	Pin Configuration and Schematic Diagram	7
Figure 2	Definitions of Electrical Characteristics	8
Figure 3	Line capacitance $C_L=f(V_R)$ $f = 1\text{MHz}$, from pin 1 to pin 2	10
Figure 4	Line capacitance $C_L=f(f)$, from pin 1 to pin 2	10
Figure 5	Line capacitance $C_L=f(T_A)$, from pin 1 to pin 2	11
Figure 6	Reverse current $I_R=f(T_A)$, $V_R=3.3\text{ V}$, from pin 1 to pin 2	11
Figure 7	Clamping voltage $V_{TLP}=f(I_{TLP})$, from pin 1 to pin 2[1]	12
Figure 8	Forward clamping voltage $V_{TLP}=f(I_{TLP})$, from pin 2 to pin 1[1]	12
Figure 9	Single line, uni-directional ESD / Transient protection[2]	13
Figure 10	Ordering information scheme	14
Figure 11	PG-TSSLP-2-1: Package overview	15
Figure 12	PG-TSSLP-2-1: Footprint	15
Figure 13	PG-TSSLP-2-1: Packing	15
Figure 14	PG-TSSLP-2-1: Marking (example)	15
Figure 15	PG-TSLP-2-7: Package overview	16
Figure 16	PG-TSLP-2-7: Footprint	16
Figure 17	PG-TSLP-2-7: Packing	16
Figure 18	PG-TSLP-2-7: Marking (example)	16

List of Tables

Table 1	Ordering Information	7
Table 2	Maximum Rating at $T_A = 25\text{ °C}$, unless otherwise specified	8
Table 3	DC Characteristics at $T_A = 25\text{ °C}$, unless otherwise specified	8
Table 4	RF Characteristics at $T_A = 25\text{ °C}$, unless otherwise specified	9
Table 5	ESD Characteristics at $T_A = 25\text{ °C}$, unless otherwise specified	9

1 Uni-directional Ultra-low Capacitance ESD / Transient Protection Diode

1.1 Features

- ESD / Transient protection of high speed data lines exceeding
 - IEC61000-4-2 (ESD): ± 20 kV (air / contact)
 - IEC61000-4-4 (EFT): 2.5 kV / 50 A (5/50 ns)
 - IEC61000-4-5 (surge): 3 A (8/20 μ s)
- Maximum working voltage: $V_{RWM} = 3.3$ V
- Ultra low capacitance: $C_L = 0.4$ pF (typical)
- Low clamping voltage, low dynamic resistance $R_{DYN} = 0.6 \Omega$ (typical)
- Pb-free (RoHS compliant) and halogen free package, very small form factor down to $0.62 \times 0.32 \times 0.31$ mm³



1.2 Application Examples

- HDMI, USB 2.0/USB 3.0, DisplayPort, DVI
- 10/100/1000 Ethernet, Firewire, S-ATA
- Mobile HDMI Link, MDDI, MIPI, etc.

2 Product Description

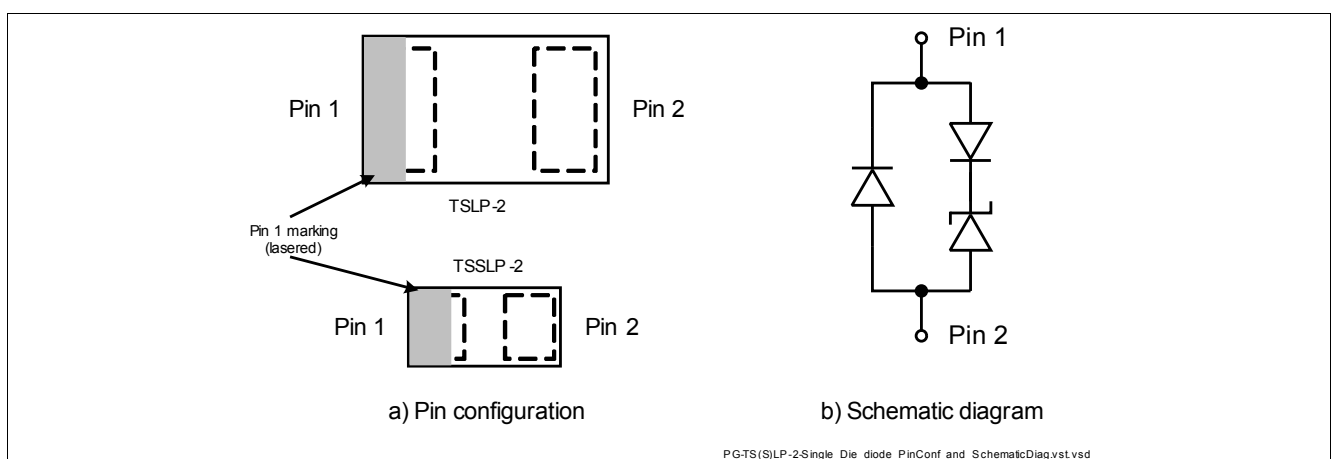

Figure 1 Pin Configuration and Schematic Diagram

Table 1 Ordering Information

Type	Package	Configuration	Marking code
ESD3V3U1U-02LS	PG-TSSLP-2-1	1 line, uni-directional	Z
ESD3V3U1U-02LRH	PG-TSLP-2-7	1 line, uni-directional	E3

3 Characteristics

Table 2 Maximum Rating at $T_A = 25\text{ }^\circ\text{C}$, unless otherwise specified

Parameter	Symbol	Values			Unit
		Min.	Typ.	Max.	
ESD (air / contact) discharge ¹⁾	V_{ESD}	–	–	20	kV
Peak pulse current ($t_p = 8/20\text{ }\mu\text{s}$) ²⁾	I_{PP}	–	–	3	A
Operating temperature range	T_{OP}	-55	–	125	$^\circ\text{C}$
Storage temperature	T_{stg}	-65	–	150	$^\circ\text{C}$

1) V_{ESD} according to IEC61000-4-2

2) I_{PP} according to IEC61000-4-5

3.1 Electrical Characteristics at $T_A = 25\text{ }^\circ\text{C}$, unless otherwise specified

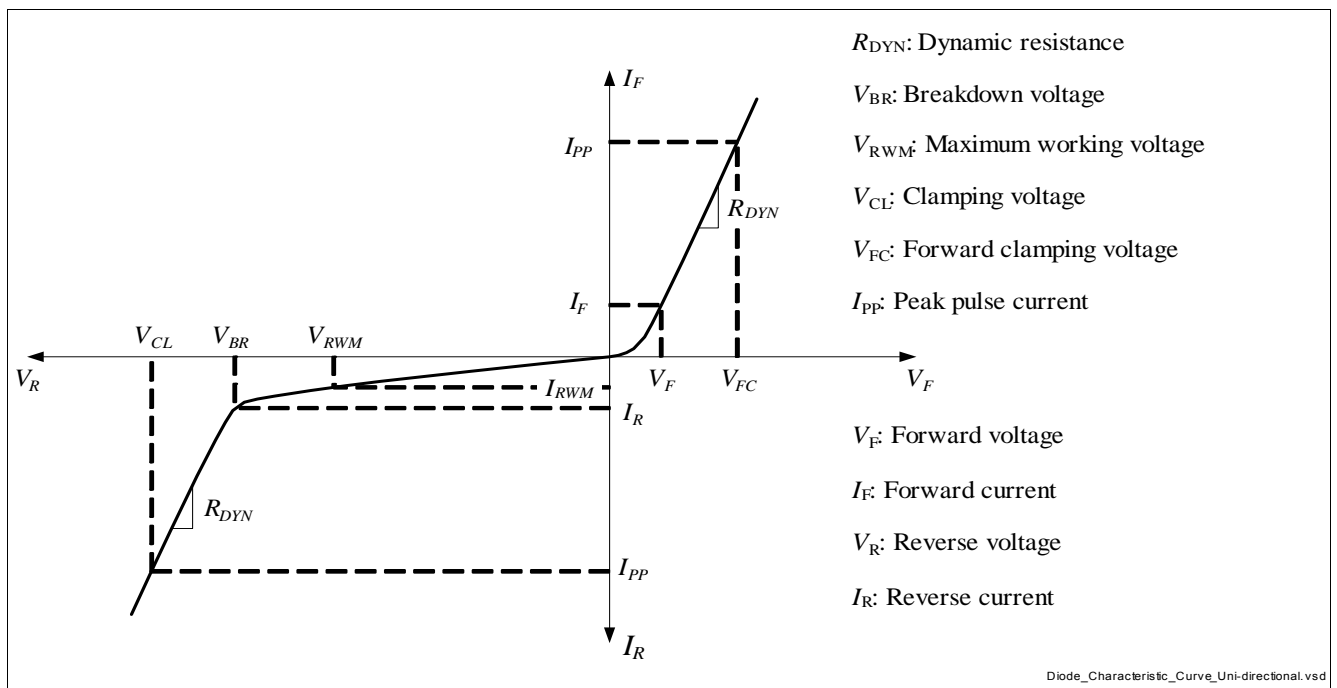

Figure 2 Definitions of Electrical Characteristics

Table 3 DC Characteristics at $T_A = 25\text{ }^\circ\text{C}$, unless otherwise specified

Parameter	Symbol	Values			Unit	Note / Test Condition
		Min.	Typ.	Max.		
Reverse working voltage	V_{RWM}	–	–	3.3	V	Pin 1 to Pin 2
Breakdown voltage	V_{BR}	5	–	–	V	$I_{BR} = 1\text{ mA}$, from Pin 1 to Pin 2
Reverse current	I_R	–	<1	50	nA	$V_R = 3.3\text{ V}$, from Pin 1 to Pin 2

Table 4 RF Characteristics at $T_A = 25\text{ }^\circ\text{C}$, unless otherwise specified

Parameter	Symbol	Values			Unit	Note / Test Condition
		Min.	Typ.	Max.		
Line capacitance ¹⁾	C_L	–	0.4	0.6	pF	$V_R = 0\text{ V}, f = 1\text{ MHz}$
Serie inductance	L_S	–	0.2	–	nH	ESD3V3U1U-02LS
		–	0.4	–	nH	ESD3V3U1U-02LRH

1) Total capacitance line to ground

Table 5 ESD Characteristics at $T_A = 25\text{ }^\circ\text{C}$, unless otherwise specified

Parameter	Symbol	Values			Unit	Note / Test Condition
		Min.	Typ.	Max.		
Clamping voltage	V_{CL}	–	19	–	V	$I_{PP} = 16\text{ A}$, from Pin 1 to Pin 2
		–	28	–	V	$I_{PP} = 30\text{ A}$, from Pin 1 to Pin 2
Forward clamping voltage	V_{FC}	–	10	–	V	$I_{PP} = 16\text{ A}$, from Pin 2 to Pin 1
		–	17	–	V	$I_{PP} = 30\text{ A}$, from Pin 2 to Pin 1
Dynamic resistance ¹⁾	R_{DYN}	–	0.6	–	Ω	Pin 1 to Pin 2
		–	0.5	–	Ω	Pin 2 to Pin 1

1) Please refer to Application Note AN210. TLP parameter: $Z_0 = 50\ \Omega$, $t_p = 100\text{ ns}$, $t_r = 300\text{ ps}$, averaging window: $t_1 = 30\text{ ns}$ to $t_2 = 60\text{ ns}$, extraction of dynamic resistance using least squares fit of TLP characteristics between $I_{PP1} = 10\text{ A}$ and $I_{PP2} = 40\text{ A}$.

3.2 Typical Characteristics at $T_A=25^\circ\text{C}$, unless otherwise specified

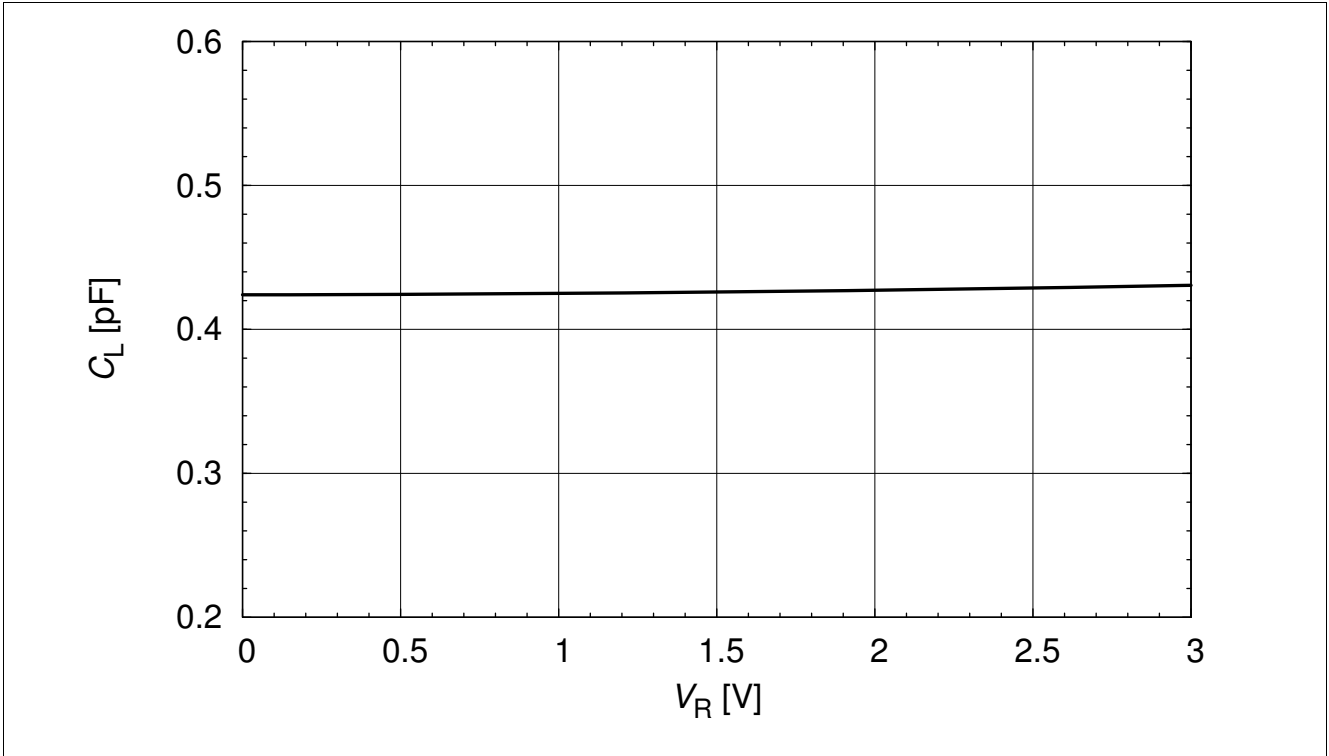

Figure 3 Line capacitance $C_L=f(V_R)$ $f = 1\text{ MHz}$, from pin 1 to pin 2

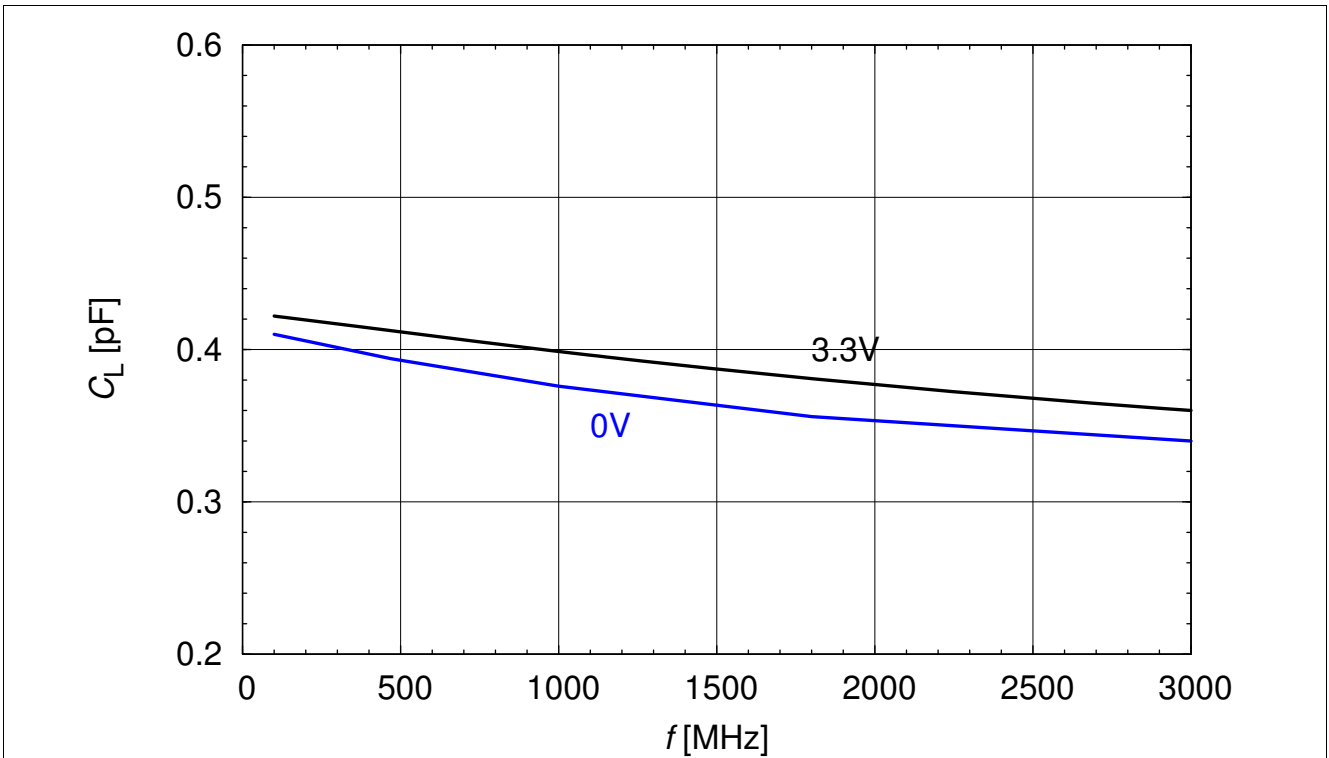

Figure 4 Line capacitance $C_L=f(f)$, from pin 1 to pin 2

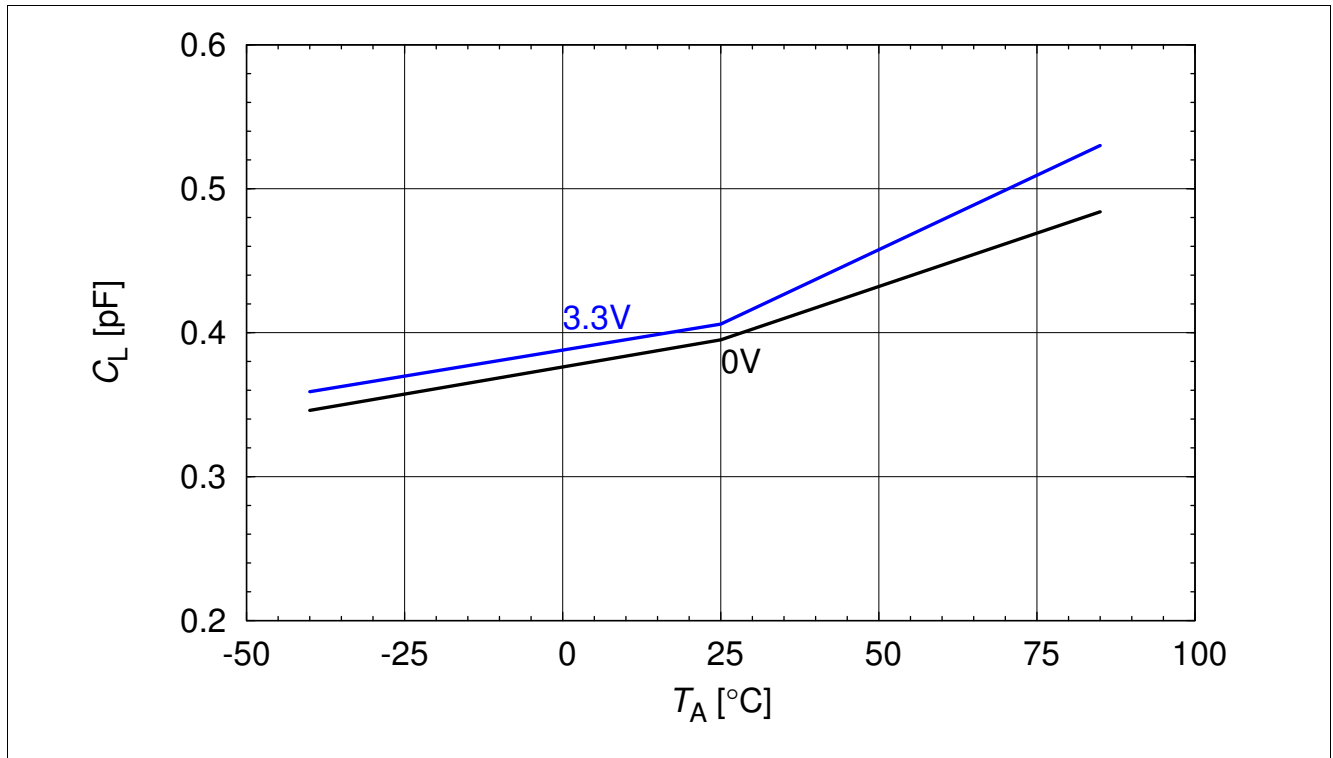

Figure 5 Line capacitance $C_L=f(T_A)$, from pin 1 to pin 2

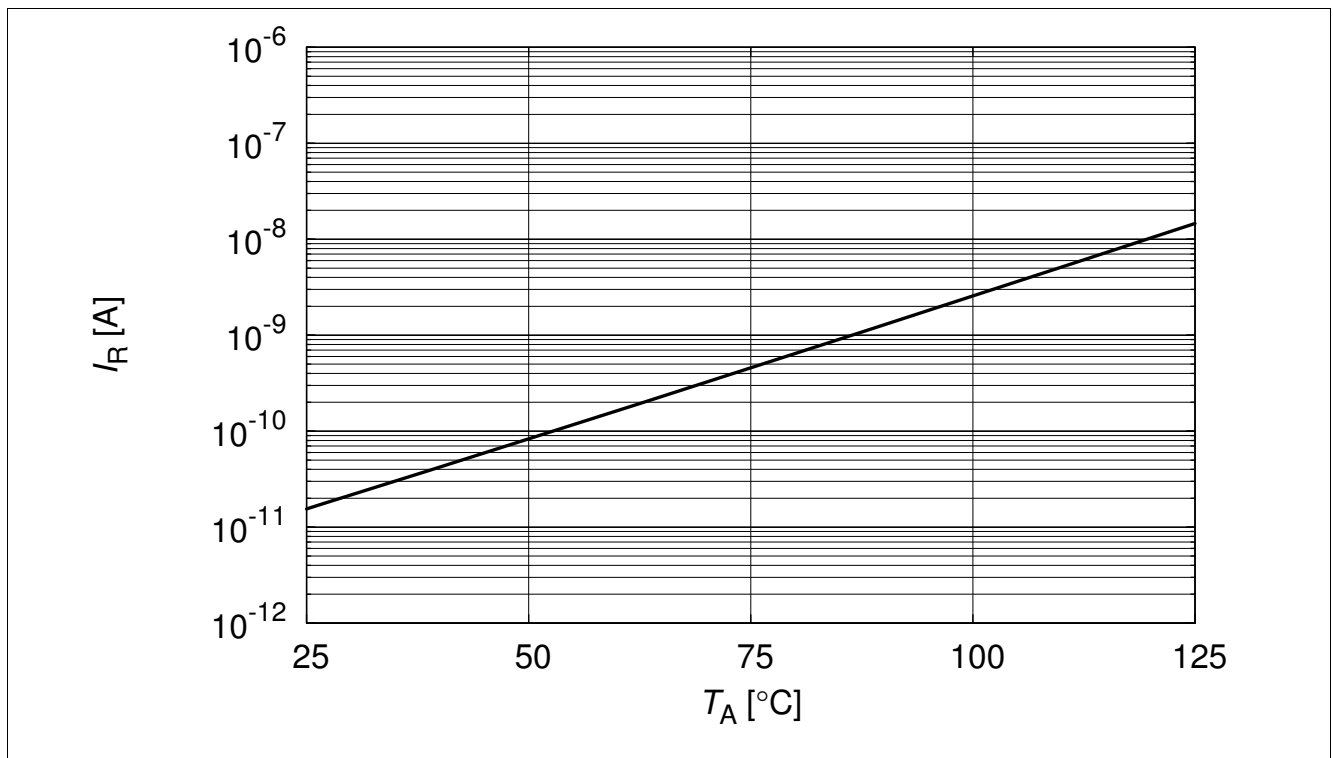

Figure 6 Reverse current $I_R=f(T_A)$, $V_R=3.3$ V, from pin 1 to pin 2

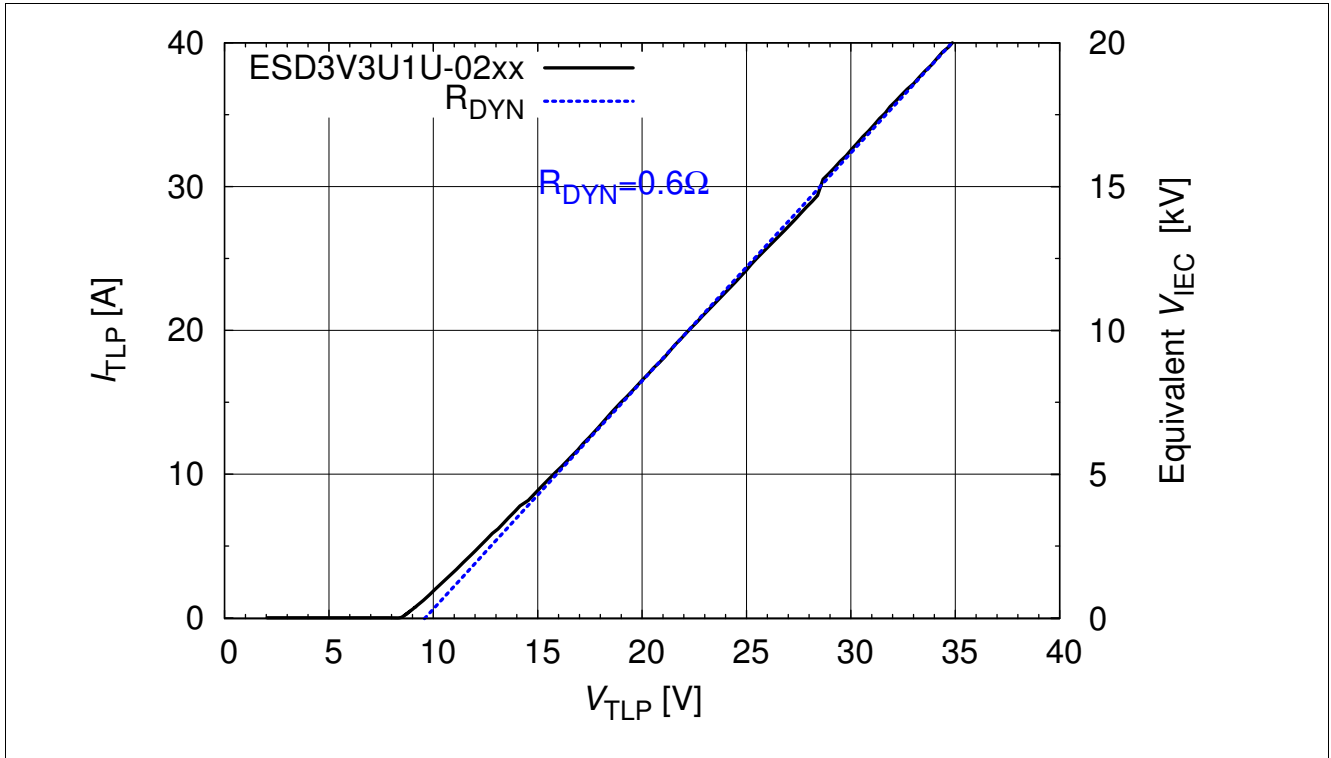

Figure 7 Clamping voltage $V_{TLP}=f(I_{TLP})$, from pin 1 to pin 2[1]

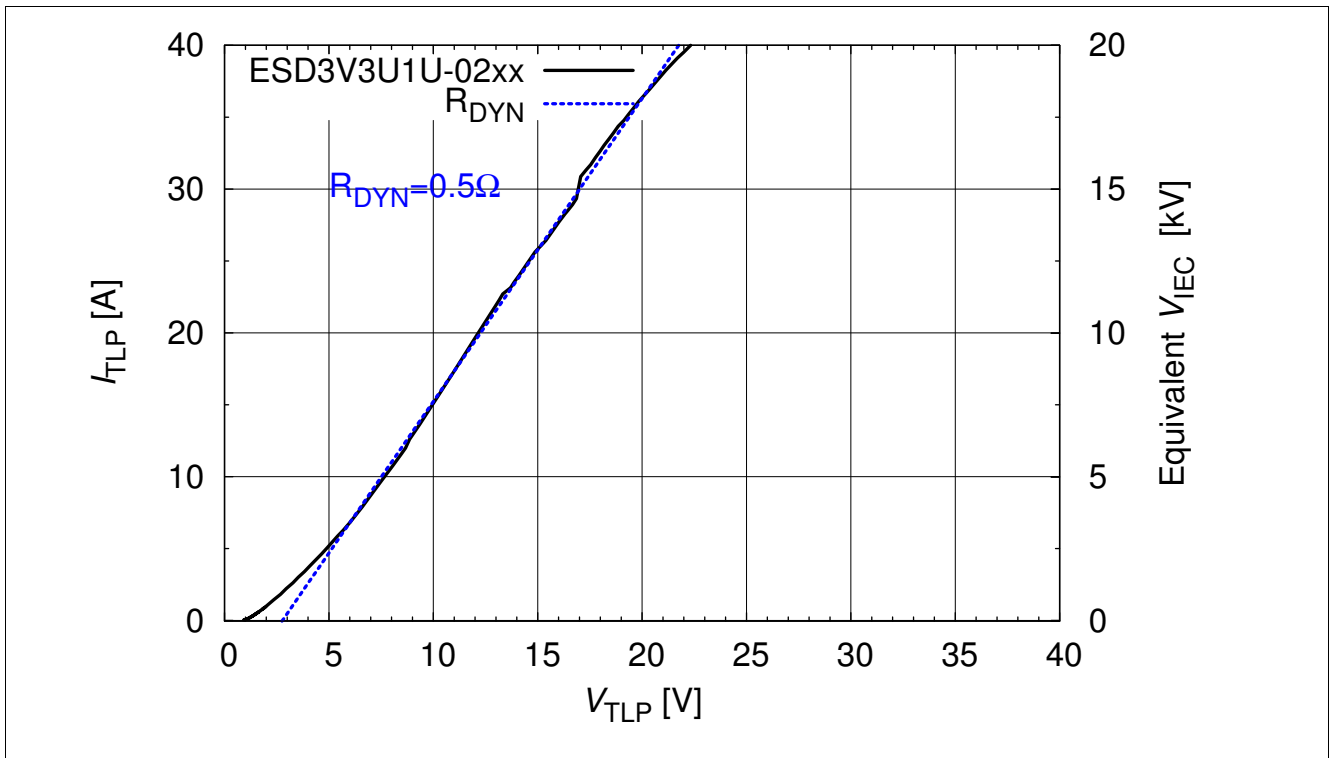

Figure 8 Forward clamping voltage $V_{TLP}=f(I_{TLP})$, from pin 2 to pin 1[1]

4 Application Information

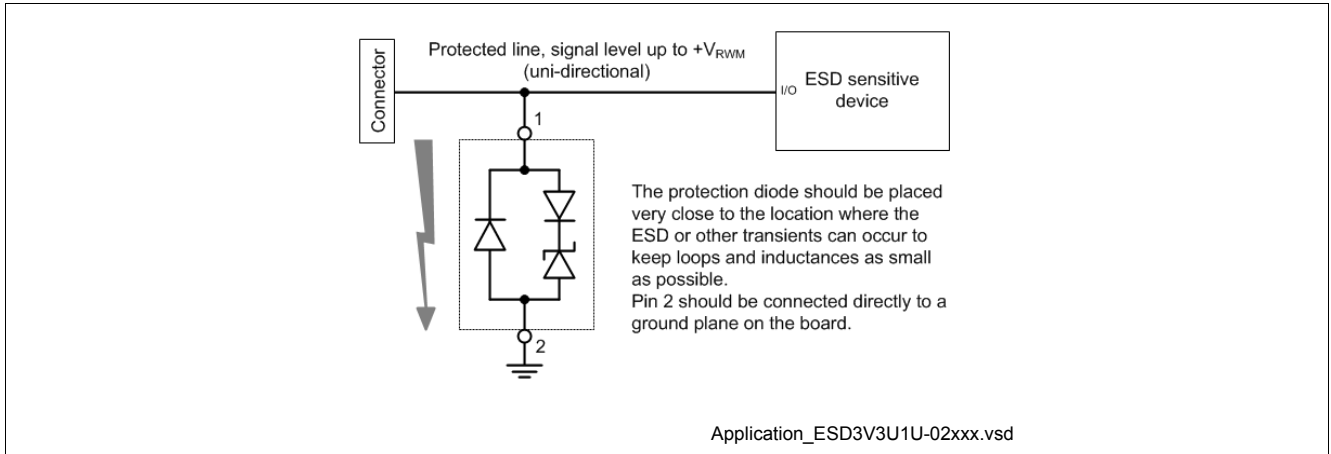

Figure 9 Single line, uni-directional ESD / Transient protection[2]

5 Ordering Information Scheme (Examples)

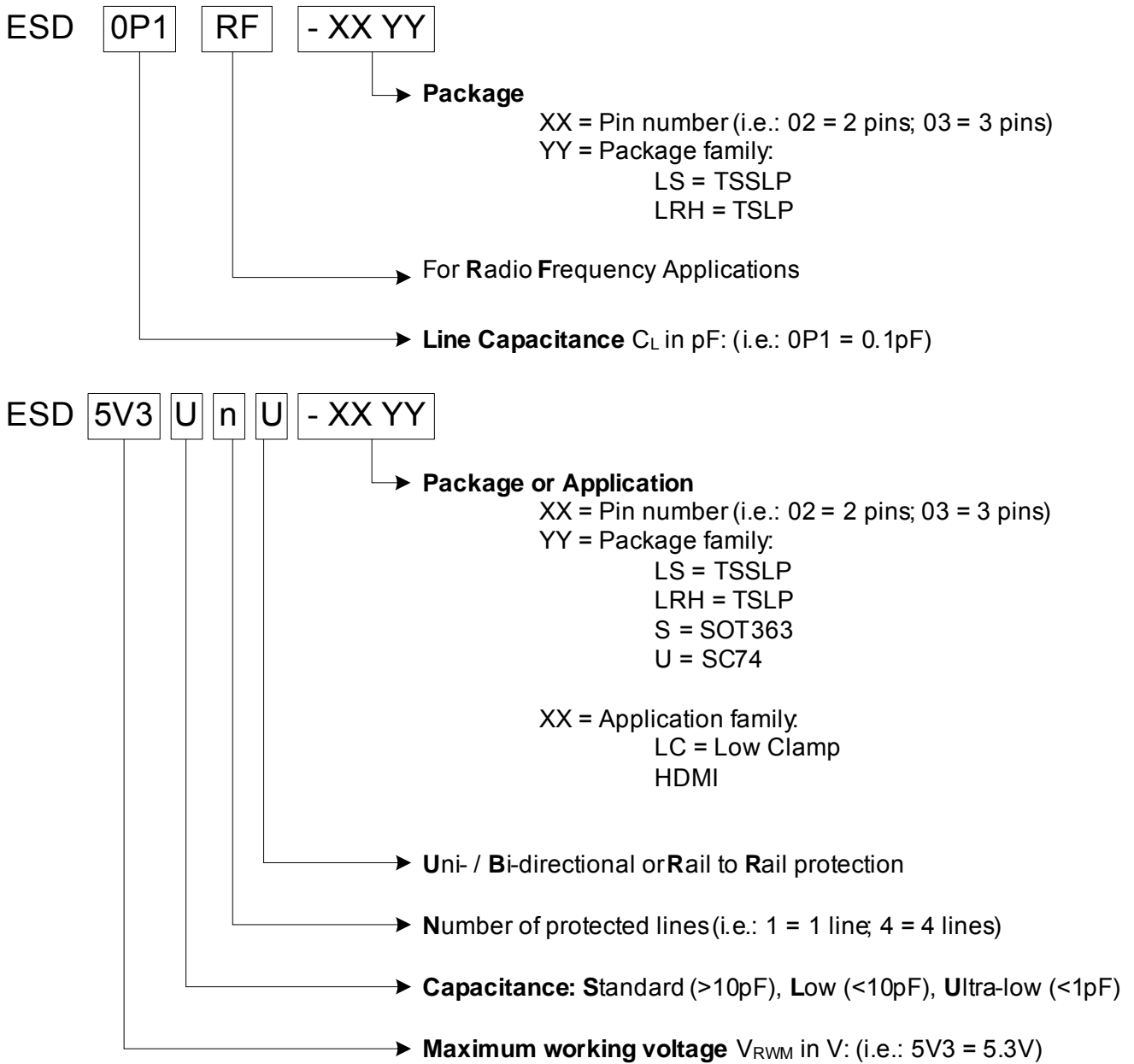

Figure 10 Ordering information scheme

6 Package Information

6.1 PG-TSSLP-2-1 (mm) [3]

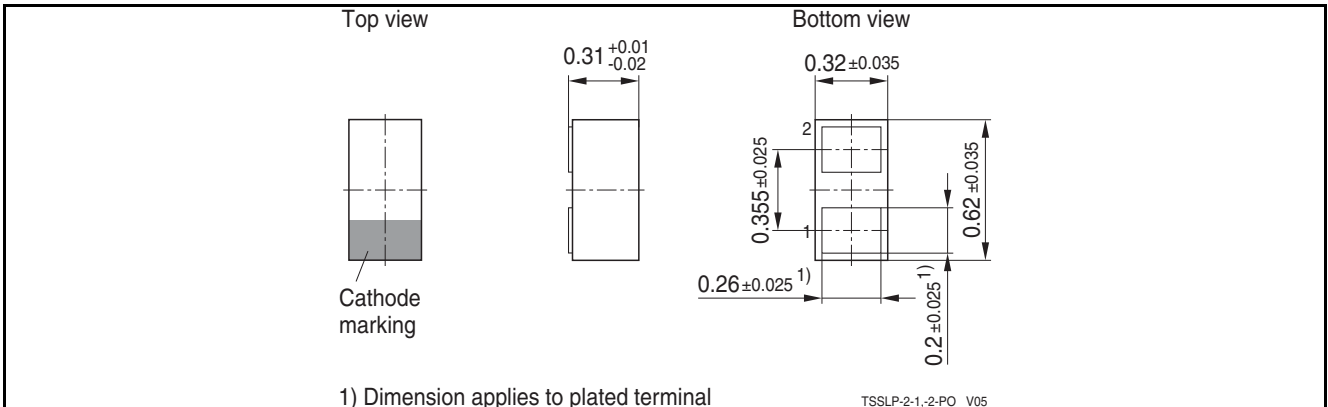

Figure 11 PG-TSSLP-2-1: Package overview

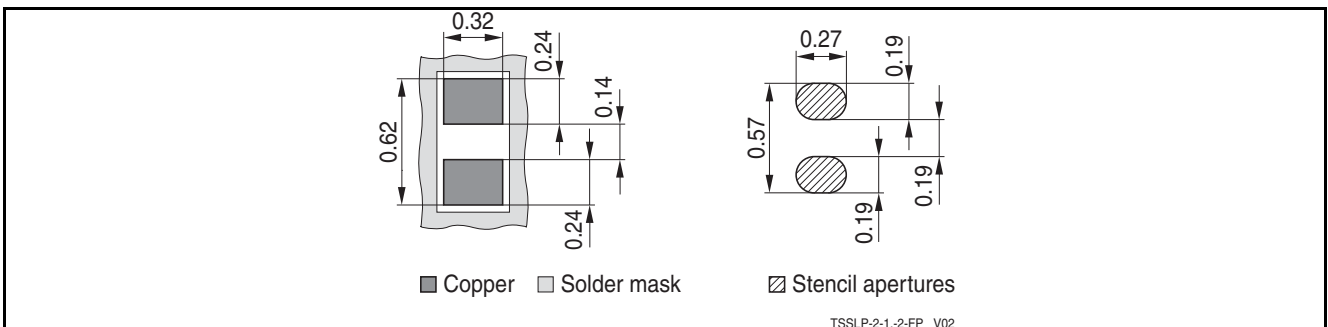

Figure 12 PG-TSSLP-2-1: Footprint

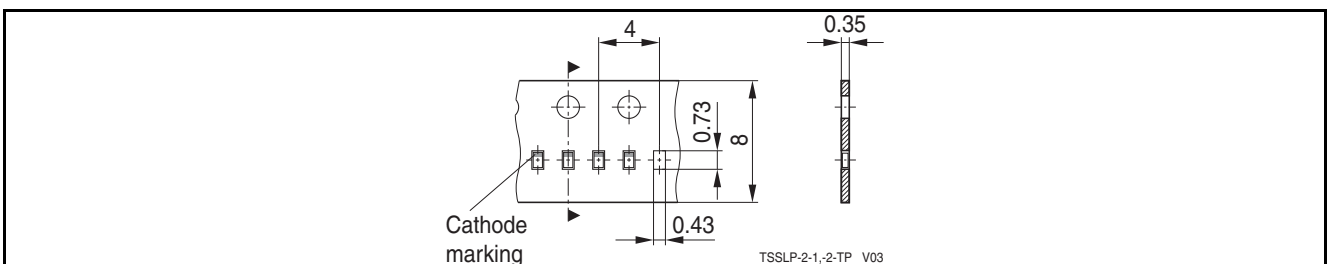

Figure 13 PG-TSSLP-2-1: Packing

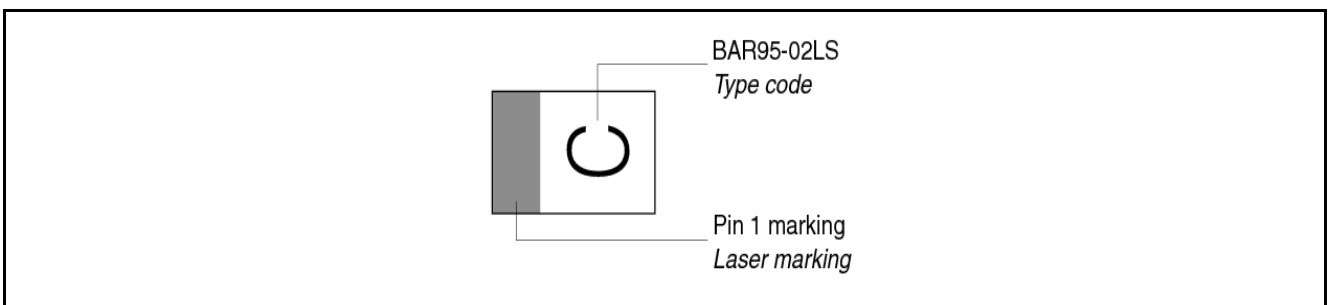

Figure 14 PG-TSSLP-2-1: Marking (example)

6.2 PG-TSLP-2-7 (mm)[3]

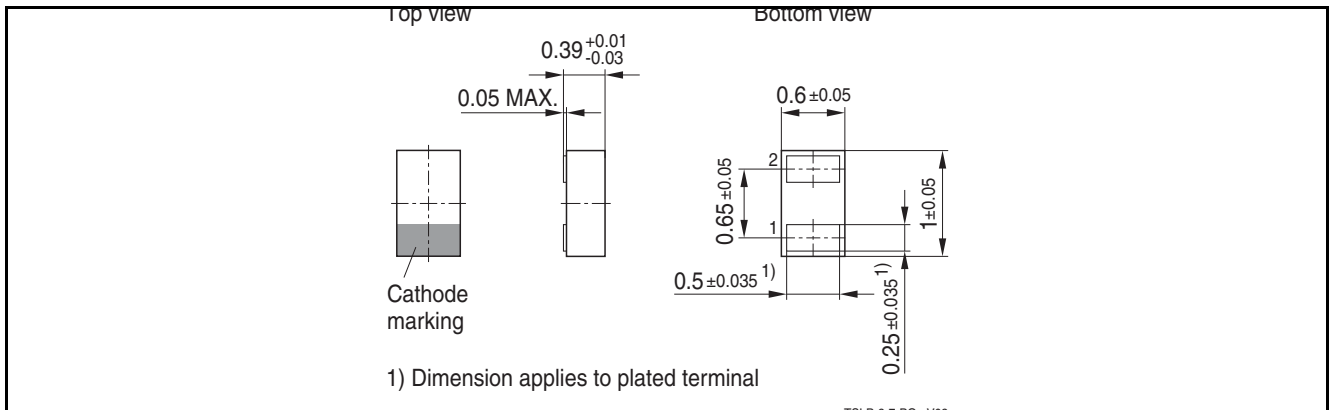

Figure 15 PG-TSLP-2-7: Package overview

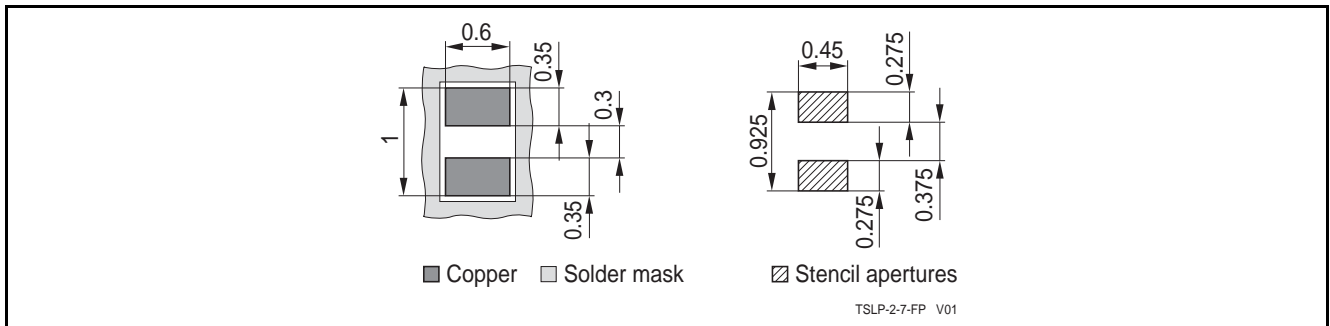

Figure 16 PG-TSLP-2-7: Footprint

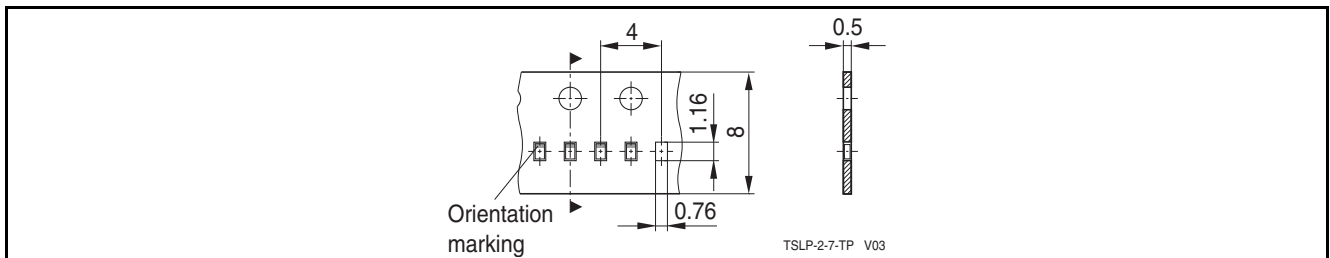

Figure 17 PG-TSLP-2-7: Packing

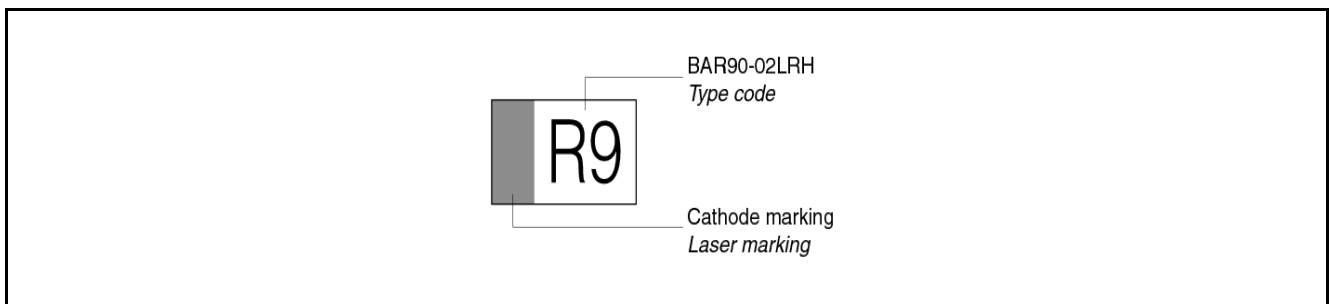

Figure 18 PG-TSLP-2-7: Marking (example)

Terminology

C_L	Line capacitance
EFT	Electrical Fast Transient
ESD	Electrostatic Discharge
HDMI	High Definition Multimedia Interface
IEC	International Electrotechnical Commission
I_{PP}	Peak pulse current
I_R	Reverse current
I_{RWM}	Maximum Reverse working Current
LCD	Liquid Crystal Display
L_S	Serial inductance
MDDI	Mobile Display Digital Interface
MIPI	Mobile Industrial Processor Interface
RoHS	Restriction of Hazardous Substances Directive
S-ATA	Serial Advanced Technology Attachment
T_A	Ambient temperature
T_{OP}	Operation temperature
t_p	Pulse duration
T_{stg}	Storage temperature
USB	Universal Serial Bus
V_{BR}	Breakdown Voltage
V_{CL}	Reverse Clamping Voltage
V_{ESD}	Electrostatic Discharge Voltage
V_{FC}	Forward Clamping Voltage
V_R	Reverse Voltage
V_{RWM}	Maximum Reverse Working Voltage

References

- [1] Infineon AG - **Application Note AN210**: Effective ESD Protection Design at System Level Using VF-TLP Characterization Methodology
- [2] Infineon AG - **Application Note AN140**: ESD Protection for Digital High-Speed Interfaces (HDMI, FireWire, ...) using ESD5V3U1U)
- [3] Infineon AG - Recommendations for PCB Assembly of Infineon TSLP and TSSLP Package

www.infineon.com

Published by Infineon Technologies AG