

# BTS441RG

Smart Power High-Side-Switch  
One Channel 20 mΩ

## Data sheet

Rev. 1.21, 2012-12-06

Automotive Power



## 1 Overview

### General Description

- N channel vertical power FET with charge pump, ground referenced CMOS compatible input, monolithically integrated in Smart SiPMOS technology
- Providing embedded protective functions
- Green Product (RoHS compliant)
- AEC Qualified

### Application

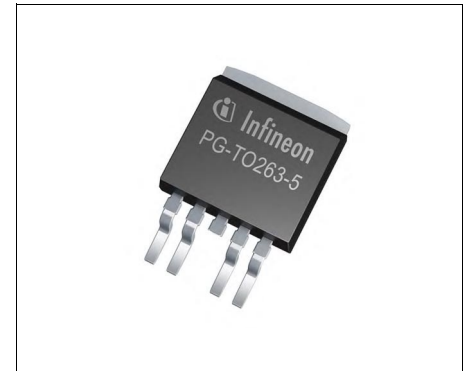
- $\mu$ C compatible power switch 5 V, 12 V and 24 V DC applications
- All types of resistive, inductive and capacitive loads
- Most suitable for loads with high inrush currents, so as lamps
- Replaces electromechanical relays, fuses and discrete circuits

### Basic Functions

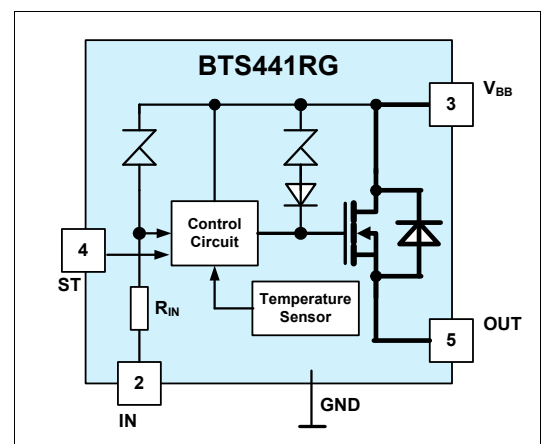
- Very low standby current
- Optimized static electromagnetic compatibility (EMC)
- $\mu$ C and CMOS compatible
- Fast demagnetization of inductive loads
- Stable behavior at undervoltage

### Protection Functions

- Short circuit protection
- Current limitation
- Overload protection
- Thermal Shutdown
- Overvoltage protection (including load dump) with external GND resistor
- Reverse battery protection with external GND-resistor
- Loss of ground and loss of  $V_{bb}$  protection
- Electrostatic discharge (ESD) protection



**PG-TO263-5**



Type	Package	Marking
BTS441RG	PG-TO263-5	BTS441R

**Diagnostic Function**

- Diagnostic feedback with open drain output
- Open load detection in OFF-state
- Feedback of thermal shutdown in ON-state

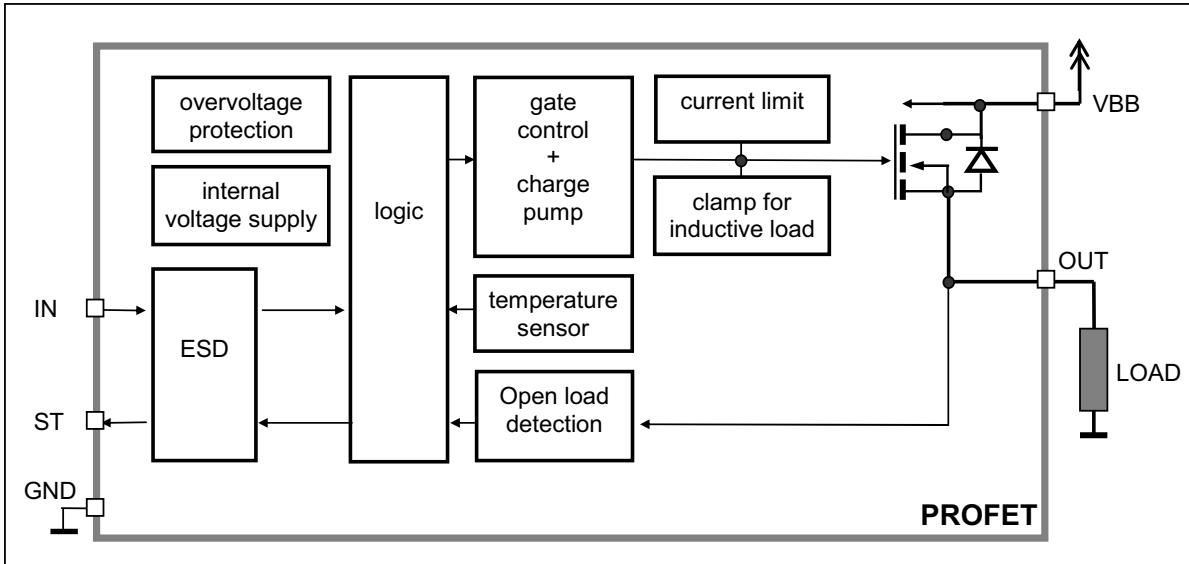
**Product Summary**

Maximum on-state resistance at $T_j = 150\text{ °C}$	$R_{DS(ON)}$	20 mΩ
Operating voltage	$V_{SOP}$	4.75 V ... 41 V
Nominal load current	$I_{L(nom)}$	21 A
Current limitation	$I_{L(lim)}$	65 A

**Product Information**

Device Name	Status	Package	Pins	ECO status
BTS441RG	Active	PG-TO263-5	5	Green
BTS441RG	Discontinued	P-TO263-5	5	Gray
BTS441RS	Discontinued	P-TO220-5	5	Gray
BTS441RS	Discontinued	PG-TO220-5	5	Green

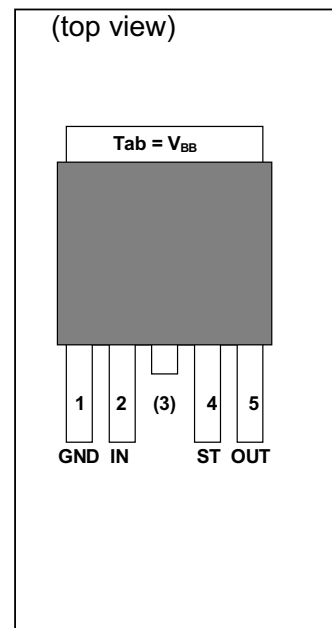
**Functional diagram**



**Pin Definitions and Functions**

Pin	Symbol	Function
1	GND	<b>Logic ground</b>
2	IN	<b>Input</b> , activates the power switch in case of logical high signal
3	V <sub>bb</sub>	<b>Positive power supply voltage</b> The tab is shorted to pin 3
4	ST	<b>Diagnostic feedback</b> , low on failure
5	OUT	<b>Output to the load</b>
Tab	V <sub>bb</sub>	<b>Positive power supply voltage</b> The tab is shorted to pin 3

**Pin configuration**



**Maximum Ratings** at  $T_j = 25\text{ °C}$  unless otherwise specified



Parameter	Symbol	Values	Unit	
Supply voltage (overvoltage protection see page 4)	$V_{bb}$	43	V	
Supply voltage for full short circuit protection $T_{j\text{ Start}} = -40 \dots +150\text{ °C}$	$V_{bb}$	34	V	
Load dump protection <sup>1)</sup> $V_{\text{Load Dump}} = V_A + V_S$ , $V_A = 13.5\text{ V}$ $R_1^2 = 2\ \Omega$ , $R_L = 0,5\ \Omega$ , $t_d = 200\text{ ms}$ , IN= low or high	$V_{\text{Load dump}}^3)$	60	V	
Load current (Short-circuit current, see page 5)	$I_L$	self-limited	A	
Operating temperature range	$T_j$	-40 ... +150	°C	
Storage temperature range	$T_{\text{stg}}$	-55 ... +150		
Power dissipation (DC) ; $TC \leq 25\text{ °C}$	$P_{\text{tot}}$	125	W	
Maximal switchable inductance, single pulse $V_{bb} = 12\text{ V}$ , $T_{j,\text{start}} = 150\text{ °C}$ , $T_C = 150\text{ °C}$ const. (see diagram, p.7) $I_{L(\text{ISO})} = 21\text{ A}$ , $R_L = 0\ \Omega$ ; $E^4_{\text{AS}} = 0.7\text{ J}$ :	$Z_L$	2.1	mH	
Electrostatic discharge capability (ESD) (Human Body Model) IN: ST: Out to all other pins shorted: acc. MIL-STD883D, method 3015.7 and ESD assn. std. S5.1-1993; $R = 1.5\text{ k}\Omega$ ; $C = 100\text{ pF}$	$V_{\text{ESD}}$	1.0 4.0 8.0	kV	
Input voltage (DC)	$V_{\text{IN}}$	-10 ... +16	V	
Current through input pin (DC)	$I_{\text{IN}}$	$\pm 2.0$	mA	
Current through status pin (DC) see internal circuit diagrams page 7	$I_{\text{ST}}$	$\pm 5.0$		
Thermal resistance	chip - case: junction - ambient (free air): SMD version, device on pcb <sup>5)</sup> :	$R_{\text{thJC}}$ $R_{\text{thJA}}$	$\leq 1$ $\leq 75$ $\leq 33$	K/W

- 1) Supply voltages higher than  $V_{bb(\text{AZ})}$  require an external current limit for the GND pin, e.g. with a  $150\ \Omega$  resistor in the GND connection. A resistor for the protection of the input is integrated.
- 2)  $R_1$  = internal resistance of the load dump test pulse generator
- 3)  $V_{\text{Load dump}}$  is setup without the DUT connected to the generator per ISO 7637-1 and DIN 40839
- 4)  $E_{\text{AS}}$  is the maximum inductive switch off energy
- 5) Device on  $50\text{ mm} \times 50\text{ mm} \times 1.5\text{ mm}$  epoxy PCB FR4 with  $6\text{ cm}^2$  (one layer,  $70\ \mu\text{m}$  thick) copper area for  $V_{bb}$  connection. PCB is vertical without blown air.

## Electrical Characteristics

Parameter and Conditions at $T_j = -40...+150^\circ\text{C}$ , $V_{bb} = 12\text{ V}$ unless otherwise specified	Symbol	Values			Unit
		min	typ	max	

### Load Switching Capabilities and Characteristics

On-state resistance ( $V_{bb}$ (pin3) to OUT (pin5)); $I_L = 2\text{ A}$ , $V_{bb} \geq 7\text{ V}$ ; $T_j = 25^\circ\text{C}$ : $T_j = 150^\circ\text{C}$ : see diagram page 9	$R_{ON}$	--	15 28	20 37	m $\Omega$
Nominal load current (pin 3 to 5) ISO 10483-1, 6.7: $V_{ON} = 0.5\text{ V}$ , $T_c = 85^\circ\text{C}$	$I_{L(ISO)}$	17	21	--	A
Output current (pin 5) while GND disconnected or GND pulled up <sup>6)</sup> , $V_{bb} = 30\text{ V}$ , $V_{IN} = 0$ , see diagram page 7	$I_{L(GNDhigh)}$	--	--	2	mA
Turn-on time Turn-off time $R_L = 12\ \Omega$ ,	IN  to 90% $V_{OUT}$ : IN  to 10% $V_{OUT}$ : $t_{on}$ $t_{off}$	40 40	90 110	200 250	$\mu\text{s}$
Slew rate on 10 to 30% $V_{OUT}$ , $R_L = 12\ \Omega$ ,	$dV/dt_{on}$	0.1	--	1	V/ $\mu\text{s}$
Slew rate off 70 to 40% $V_{OUT}$ , $R_L = 12\ \Omega$ ,	$-dV/dt_{off}$	0.1	--	1	V/ $\mu\text{s}$

### Operating Parameters

Operating voltage $T_j = -40^\circ\text{C}$ $T_j = +25^\circ\text{C}$ $T_j = +105^\circ\text{C}$ <sup>6)</sup> $T_j = +150^\circ\text{C}$	$V_{bb(on)}$	4.75 4.75 4.75 5.0	-- -- -- --	41 43 43 43	V
Overvoltage protection <sup>7)</sup> $I_{bb} = 40\text{ mA}$ $T_j = -40^\circ\text{C}$ : $T_j = +25...+150^\circ\text{C}$ :	$V_{bb(AZ)}$	41 43	-- 47	-- 52	V
Standby current (pin 3) <sup>8)</sup> $T_j = -40...+25^\circ\text{C}$ : $T_j = +105^\circ\text{C}$ <sup>6)</sup> : $T_j = +150^\circ\text{C}$ : $V_{IN} = 0$ see diagram page 9	$I_{bb(off)}$	-- -- --	-- -- --	5 10 25	$\mu\text{A}$
Off-State output current (included in $I_{bb(off)}$ ) $V_{IN} = 0$	$I_{L(off)}$	--	1.5	10	$\mu\text{A}$
Operating current (Pin 1) <sup>9)</sup> , $V_{IN} = 5\text{ V}$ ,	$I_{GND}$	--	2	4	mA

6) not subject to production test, specified by design

7) see also  $V_{ON(CL)}$  in table of protection functions and circuit diagram page 7

8) Measured with load, typ. 40  $\mu\text{A}$  when no load in off

9) Add  $I_{ST}$ , if  $I_{ST} > 0$ , add  $I_{IN}$ , if  $V_{IN} > 5.5\text{ V}$

Parameter and Conditions at $T_j = -40\dots+150^\circ\text{C}$ , $V_{bb} = 12\text{ V}$ unless otherwise specified	Symbol	Values			Unit	
		min	typ	max		
<b>Protection Functions<sup>10)</sup></b>						
Current limit (pin 3 to 5) (see timing diagrams, page 9)	$T_j = -40^\circ\text{C}$ : $T_j = 25^\circ\text{C}$ : $T_j = +150^\circ\text{C}$ :	$I_{L(\text{lim})}$	-- -- 40	-- 65 --	85 -- --	A
Repetitive short circuit current limit $T_j = T_{jt}$ (see timing diagrams, page 10)		$I_{L(\text{SCr})}$	--	55	--	A
Thermal shutdown time <sup>11)12)</sup> (see timing diagram on page 10)	$T_{j,\text{start}} = 25^\circ\text{C}$ :	$T_{\text{off}(\text{SC})}$	--	14	--	ms
Output clamp (inductive load switch off) at $V_{\text{OUT}} = V_{bb} - V_{\text{ON}(\text{CL})}$ , $I_L = 40\text{ mA}$	$T_j = -40^\circ\text{C}$ : $T_j = 25\dots150^\circ\text{C}$ :	$V_{\text{ON}(\text{CL})}$	41 43	-- 47	-- 52	V
Thermal overload trip temperature		$T_{jt}$	150	--	--	$^\circ\text{C}$
Thermal hysteresis		$\Delta T_{jt}$	--	10	--	K
Reverse battery (pin 3 to 1) <sup>13)</sup>		$-V_{bb}$	--	--	32	V
Reverse battery voltage drop ( $V_{\text{OUT}} > V_{bb}$ ) $I_L = -2\text{ A}$	$T_j = +150^\circ\text{C}$ :	$-V_{\text{ON}(\text{rev})}$	--	540	--	mV

<sup>10)</sup> Integrated protection functions are designed to prevent IC destruction under fault conditions described in the data sheet. Fault conditions are considered as "outside" normal operating range. Protection functions are not designed for continuous repetitive operation.

<sup>11)</sup> not subject to production test, specified by design

<sup>12)</sup> Device on 50mm\*50mm\*1.5mm epoxy PCB FR4 with 6cm<sup>2</sup> (one layer, 70μm thick) copper area for  $V_{bb}$  connection. PCB is vertical without blown air.



<sup>13)</sup> Requires 150 Ω resistor in GND connection. The reverse load current through the intrinsic drain-source diode has to be limited by the connected load. Note that the power dissipation is higher compared to normal operating conditions due to the voltage drop across the intrinsic drain-source diode. The temperature protection is not active during reverse current operation! Input and Status currents have to be limited (see max. ratings page 1 and circuit page 7).

Parameter and Conditions at $T_j = -40...+150^\circ\text{C}$ , $V_{bb} = 12\text{ V}$ unless otherwise specified	Symbol	Values			Unit
		min	typ	max	

### Diagnostic Characteristics

Open load detection voltage <sup>14)</sup>	$V_{\text{OUT(OL)}}$	2	3	4	V
--	----------------------	---	---	---	---

### Input and Status Feedback<sup>15)</sup>

Input resistance	see circuit page 7	$R_I$	2.5	3.8	6.5	k $\Omega$
Input turn-on threshold voltage 		$V_{\text{IN(T+)}}$	1.2	--	2.2	V
Input turn-off threshold voltage 		$V_{\text{IN(T-)}}$	0.8	--	--	V
Input threshold hysteresis		$\Delta V_{\text{IN(T)}}$	--	0.3	--	V
Off state input current (pin 2)	$V_{\text{IN}} = 0.4\text{ V}$ :	$I_{\text{IN(off)}}$	1	--	15	$\mu\text{A}$
On state input current (pin 2)	$V_{\text{IN}} = 5\text{ V}$ :	$I_{\text{IN(on)}}$	4.5	12	24	$\mu\text{A}$
Delay time for status with open load after switch off (see timing diagrams, page 11),		$t_{\text{ST delay}}$	--	--	500	$\mu\text{s}$
Status output (open drain)						
Zener limit voltage	$I_{\text{ST}} = +1.6\text{ mA}$ :	$V_{\text{ST(high)}}$	5.4	6.1	--	V
ST low voltage	$I_{\text{ST}} = +1.6\text{ mA}$ ::	$V_{\text{ST(low)}}$	--	--	0.4	

### Truth Table

	IN	OUT	ST
Normal operation	L	L	H
	H	H	H
Open load	L	Z	L <sup>16)</sup>
	H	H	H
Short circuit to $V_{bb}$	L	H	L
	H	H	H
Overtemperature	L	L	H
	H	L	L

L = "Low" Level  
H = "High" Level

Z = high impedance, potential depends on external circuit  
Status signal valid after the time delay shown in the timing diagrams

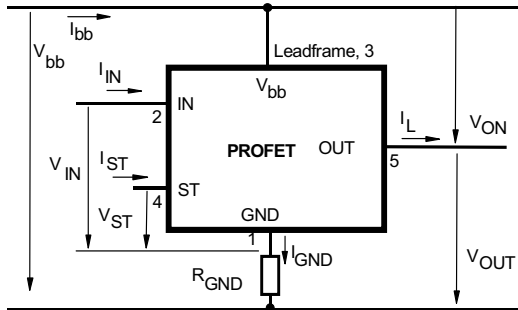
<sup>14)</sup> External pull up resistor required for open load detection in off state

<sup>15)</sup> If a ground resistor  $R_{\text{GND}}$  is used, add the voltage drop across this resistor.

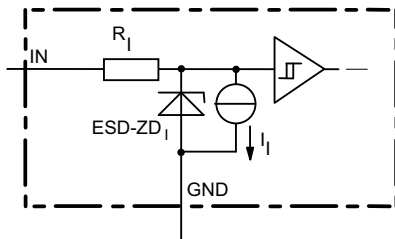
<sup>16)</sup> L, if potential at the Output exceeds the OpenLoad detection voltage



**Terms**

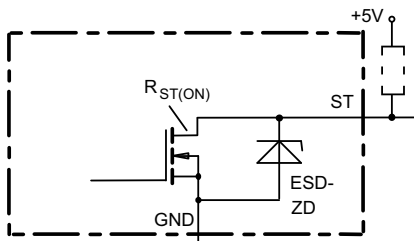


**Input circuit (ESD protection)**



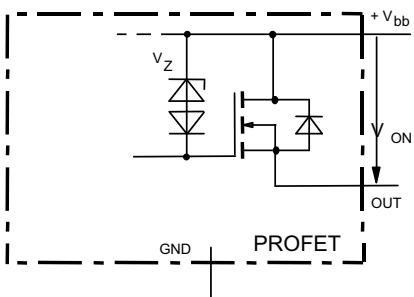
The use of ESD zener diodes as voltage clamp at DC conditions is not recommended.

**Status output**



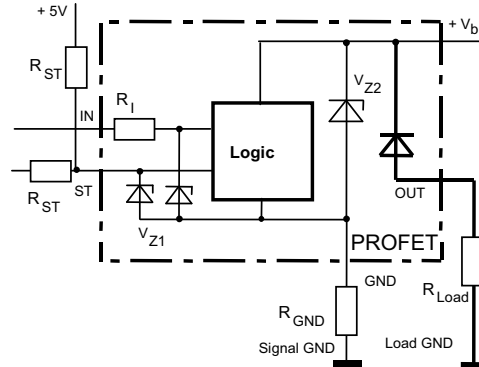
ESD-Zener diode: 6.1 V typ., max 5.0 mA;  $R_{ST(ON)} < 375 \Omega$  at 1.6 mA, ESD zener diodes are not to be used as voltage clamp at DC conditions. Operation in this mode may result in a drift of the zener voltage (increase of up to 1 V).

**Inductive and overvoltage output clamp**



$V_{ON}$  clamped to 47 V typ.

**Overvolt. and reverse batt. protection**



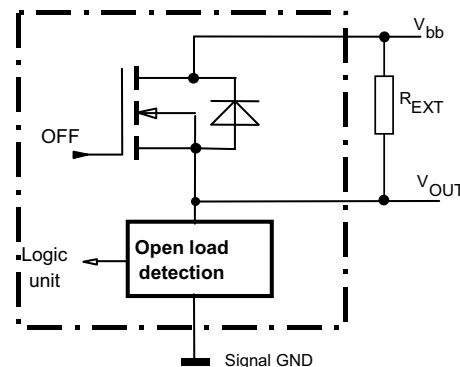
$V_{Z1} = 6.1 \text{ V typ.}$ ,  $V_{Z2} = 47 \text{ V typ.}$ ,  $R_{GND} = 150 \Omega$ ,  $R_{ST} = 15 \text{ k}\Omega$ ,  $R_I = 3.5 \text{ k}\Omega \text{ typ.}$

In case of reverse battery the load current has to be limited by the load. Temperature protection is not active

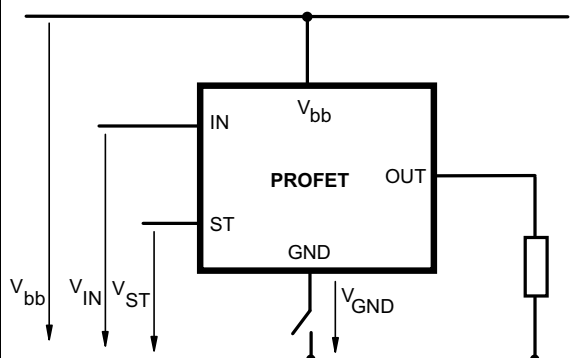
**Open-load detection**

OFF-state diagnostic condition:

Open Load, if  $V_{OUT} > 3 \text{ V typ.}$ ; IN low

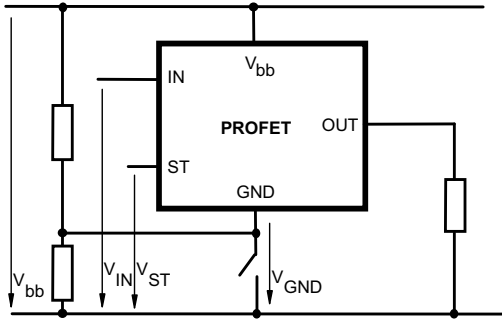


**GND disconnect**



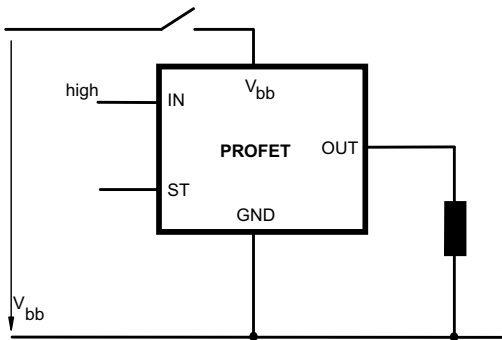
Any kind of load. In case of Input=high is  $V_{OUT} = V_{IN} - V_{IN(T+)}$ .

**GND disconnect with GND pull up**



Any kind of load. If  $V_{GND} > V_{IN} - V_{IN(T+)}$  device stays off  
 Due to  $V_{GND} > 0$ , no  $V_{ST} = \text{low}$  signal available.

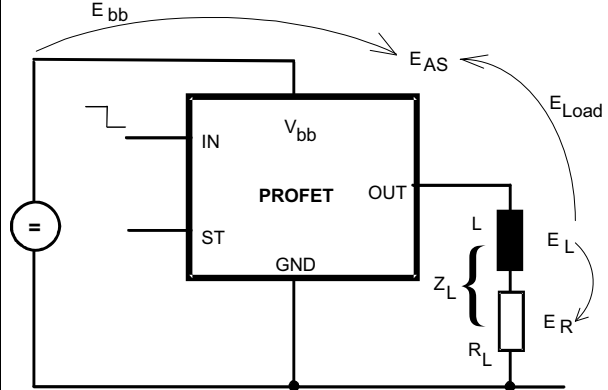
**V<sub>bb</sub> disconnect with charged inductive load**



For inductive load currents up to the limits defined by  $Z_L$  (max. ratings and diagram on page 8) each switch is protected against loss of  $V_{bb}$ .

Consider at your PCB layout that in the case of  $V_{bb}$  disconnection with energized inductive load all the load current flows through the GND connection.

**Inductive load switch-off energy dissipation**



Energy stored in load inductance:

$$E_L = 1/2 \cdot L \cdot I_L^2$$

While demagnetizing load inductance, the energy dissipated in PROFET is

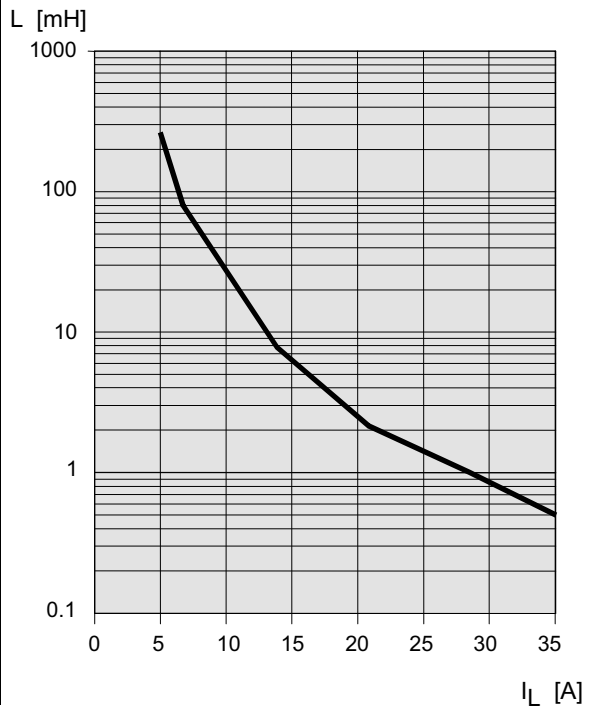
$$E_{AS} = E_{bb} + E_L - E_R = \int V_{ON(CL)} \cdot i_L(t) dt,$$

with an approximate solution for  $R_L > 0 \Omega$ :

$$E_{AS} = \frac{I_L \cdot L}{2 \cdot R_L} (V_{bb} + |V_{OUT(CL)}|) \ln \left( 1 + \frac{I_L \cdot R_L}{|V_{OUT(CL)}|} \right)$$

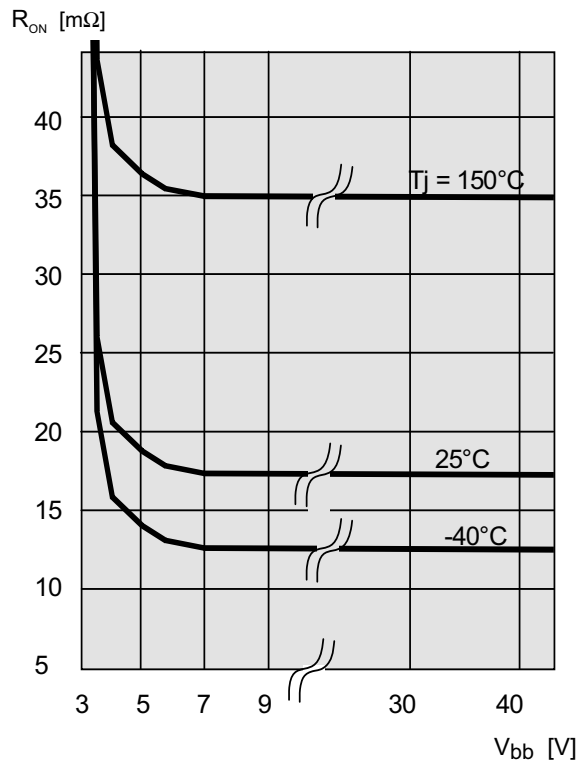
**Maximum allowable load inductance for a single switch off**

$L = f(I_L)$ ;  $T_{j,start} = 150^\circ\text{C}$ ,  $V_{bb} = 12\text{V}$ ,  $R_L = 0 \Omega$



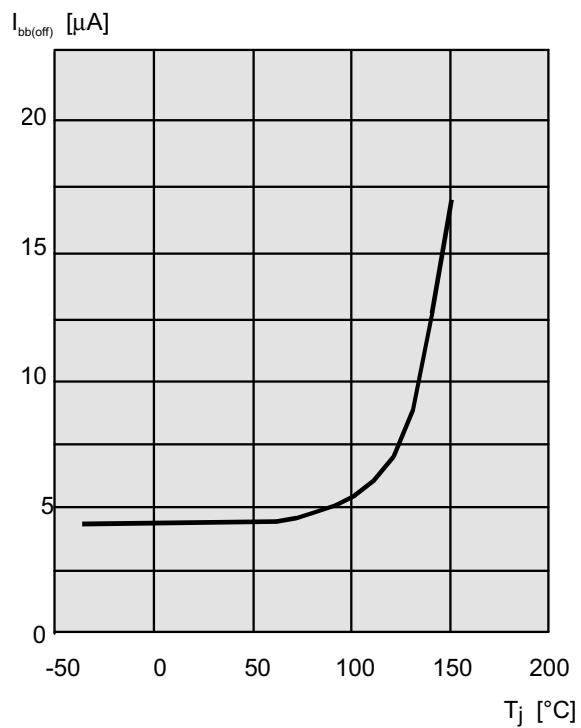
**Typ. on-state resistance**

$R_{ON} = f(V_{bb}, T_j)$ ;  $I_L = 2\text{ A}$ ,  $I_N = \text{high}$



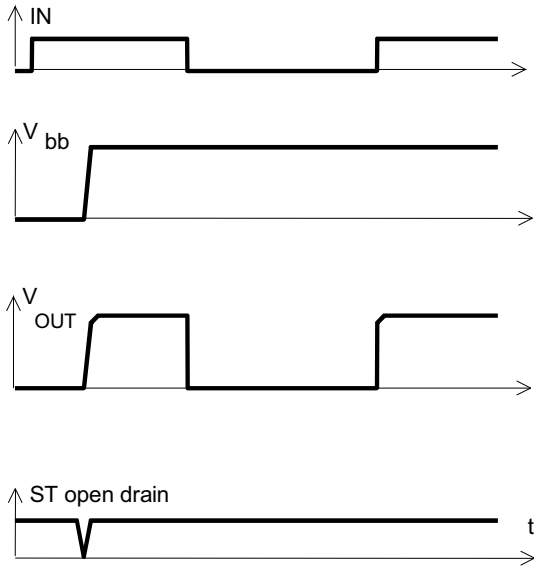
**Typ. standby current**

$I_{bb(off)} = f(T_j)$ ;  $V_{bb} = 9 \dots 34\text{ V}$ ,  $I_{N1,2} = \text{low}$



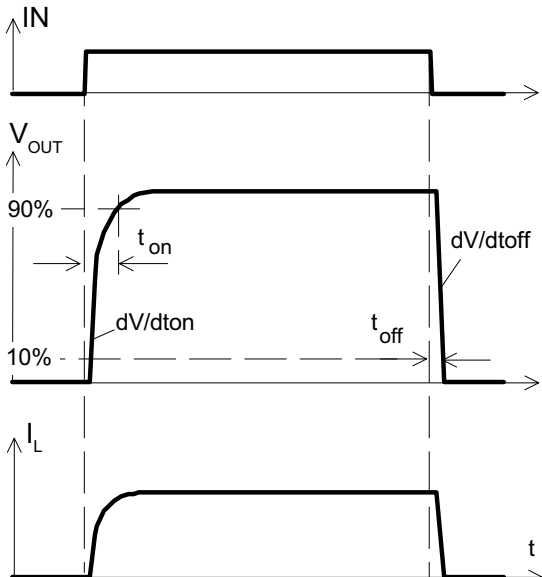
## Timing diagrams

**Figure 1a:**  $V_{bb}$  turn on:

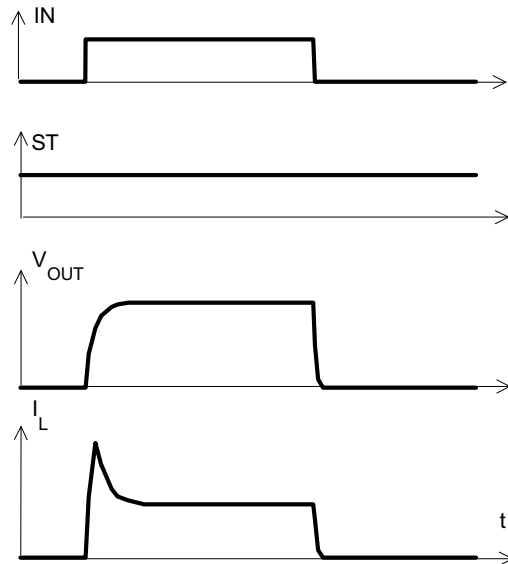


proper turn on under all conditions

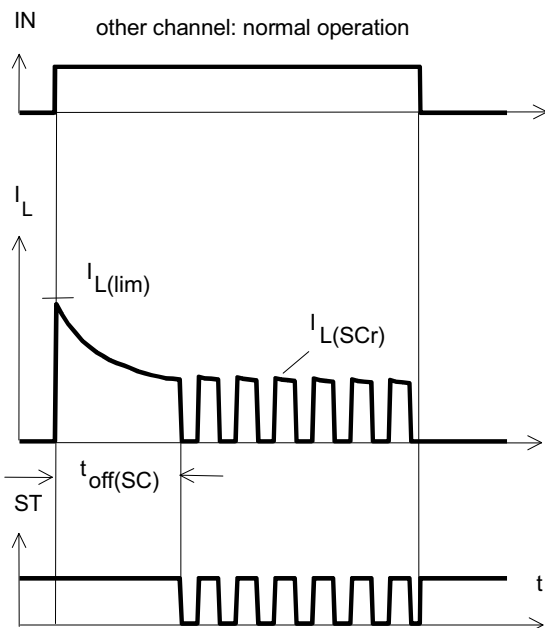
**Figure 2a:** Switching a resistive load, turn-on/off time and slew rate definition:



**Figure 2b:** Switching a lamp,

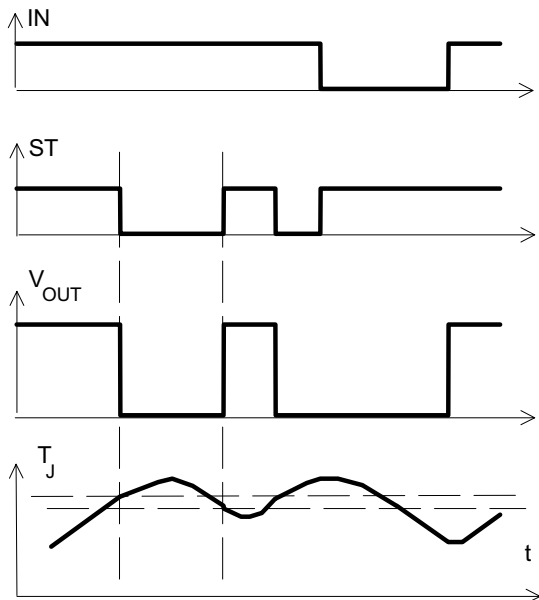


**Figure 3a:** Short circuit shut down by overtemperature, reset by cooling

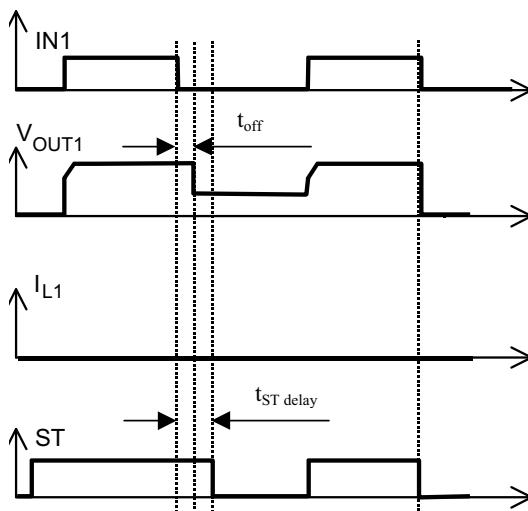


Heating up may require several milliseconds, depending on external conditions

**Figure 4a:** Overtemperature:  
Reset if  $T_j < T_{jt}$



**Figure 5a:** Open load: detection in OFF-state, turn on/off to open load



$t_{ST\ delay}^* = 500\mu s$

Open load detection requires an external pull up resistor between OUT and  $V_{BB}$

### Package Outlines

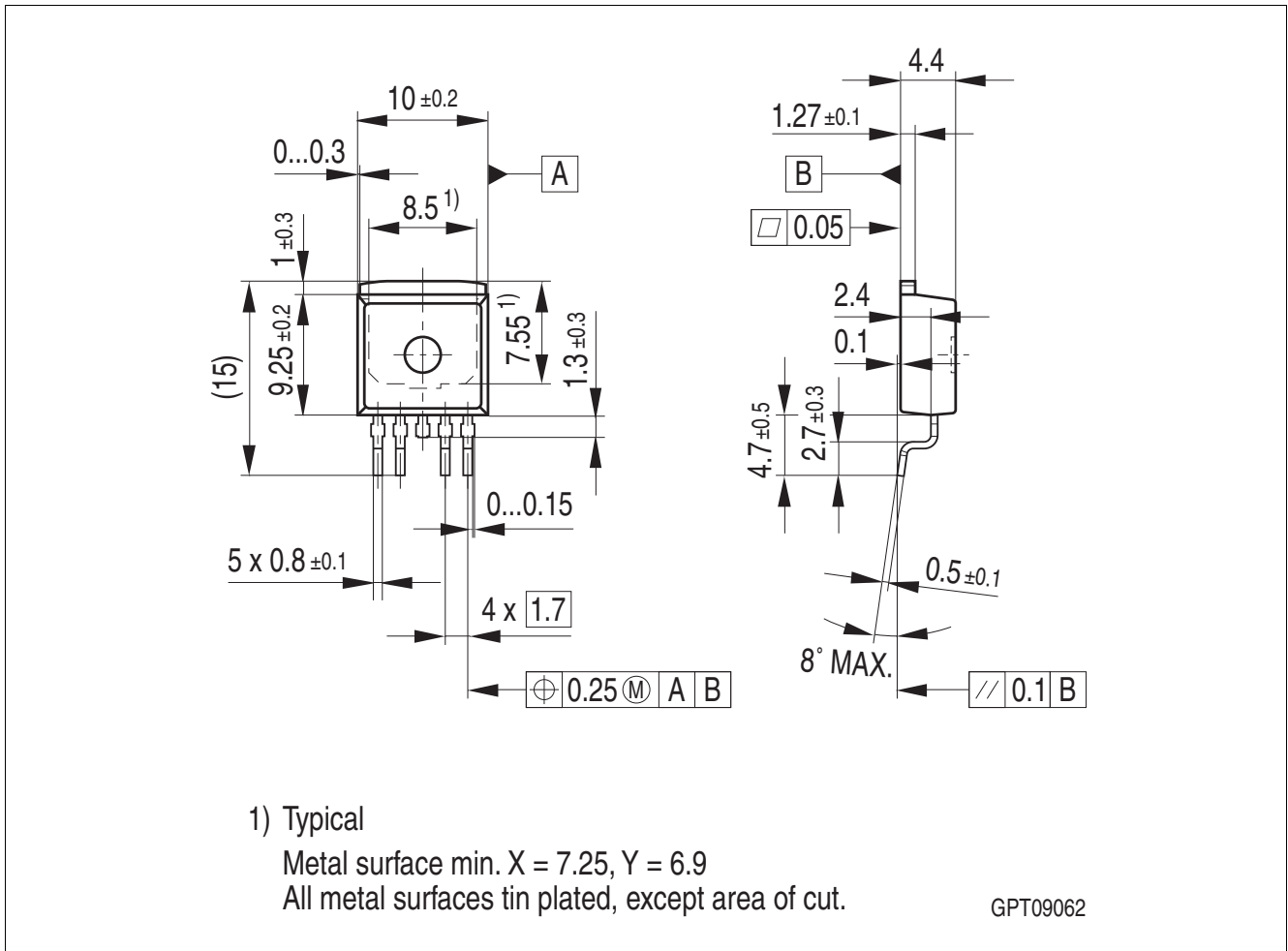


Figure 6: PG-TO263-5-2

#### Green Product (RoHS compliant)

To meet the world-wide customer requirements for environmentally friendly products and to be compliant with government regulations the device is available as a green product. Green products are RoHS-Compliant (i.e Pb-free finish on leads and suitable for Pb-free soldering according to IPC/JEDEC J-STD-020).

For further information on alternative packages, please visit our website:  
<http://www.infineon.com/packages>.

Dimensions in mm

## Revision History

Revision	Date	Changes
1.21	2012-12-06	Device marking correction on page overview.
1.20	2012-06-27	Remove PG-TO-220-5-12 package on page overview and in package outlines. Added coverpage.
1.1	2009-01-30	RoHS-compliant PG-TO220 and PG-TO263 packages version of the BTS441R All pages: Infineon logo updated Page 1: Added "AEC Qualified" and "RoHS" logo, added "Green Product (RoHS compliant)" and "AEC Qualified" statement to feature list, package names changed to RoHS compliant versions, updated package drawing. Page 12-13: Package names changed to RoHS compliant versions ( PG-TO220-12 and PG-TO263-5-2), added "Green Product" description added Revision History added Legal Disclaimer

**Edition 2012-12-06**

**Published by  
Infineon Technologies AG  
81726 Munich, Germany**

**© 2012 Infineon Technologies AG  
All Rights Reserved.**

### **Legal Disclaimer**

The information given in this document shall in no event be regarded as a guarantee of conditions or characteristics. With respect to any examples or hints given herein, any typical values stated herein and/or any information regarding the application of the device, Infineon Technologies hereby disclaims any and all warranties and liabilities of any kind, including without limitation, warranties of non-infringement of intellectual property rights of any third party.

### **Information**

For further information on technology, delivery terms and conditions and prices, please contact the nearest Infineon Technologies Office ([www.infineon.com](http://www.infineon.com)).

### **Warnings**

Due to technical requirements, components may contain dangerous substances. For information on the types in question, please contact the nearest Infineon Technologies Office.

Infineon Technologies components may be used in life-support devices or systems only with the express written approval of Infineon Technologies, if a failure of such components can reasonably be expected to cause the failure of that life-support device or system or to affect the safety or effectiveness of that device or system. Life support devices or systems are intended to be implanted in the human body or to support and/or maintain and sustain and/or protect human life. If they fail, it is reasonable to assume that the health of the user or other persons may be endangered.