

## Description

The AP3987CT is a high performance AC/DC power switcher for battery charger and adapter applications with a built-in high performance controller and a built-in 650V high performance MOSFET. It can meet less than 10mW standby power for “Super Star” charger criteria. The device uses Pulse Frequency Modulation (PFM) method to build Discontinuous Conduction Mode (DCM) Flyback power supplies.

The AP3987CT provides accurate Constant Voltage (CV), Constant Current (CC) and outstanding dynamic performance without requiring an opto-coupler. It also eliminates the need of loop compensation circuitry while maintaining stability.

The AP3987CT is equipped with built-in 0.35V output cable drop compensation.

The AP3987CT has internal over temperature protection, and also provides dedicated pin for external over temperature protection.

When the AP3987CT is used with AP4341 or APR3415CT series synchronous rectifier solution, better under-shoot performance and higher conversion efficiency can be achieved.

The AP3987CT provides operating frequency dithering function to improve system EMC performance.

The AP3987CT is packaged in SO-7.

## Applications

- Adapter/Chargers for Shaver, Cell/Cordless Phones, PDAs, MP3 and Other Portable Apparatus
- Standby and Auxiliary Power Supplies

- Notes:
1. No purposely added lead. Fully EU Directive 2002/95/EC (RoHS), 2011/65/EU (RoHS 2) & 2015/863/EU (RoHS 3) compliant.
  2. See <https://www.diodes.com/quality/lead-free/> for more information about Diodes Incorporated's definitions of Halogen- and Antimony-free, "Green" and Lead-free.
  3. Halogen- and Antimony-free "Green" products are defined as those which contain <900ppm bromine, <900ppm chlorine (<1500ppm total Br + Cl) and <1000ppm antimony compounds.

## Pin Assignments

(Top View)

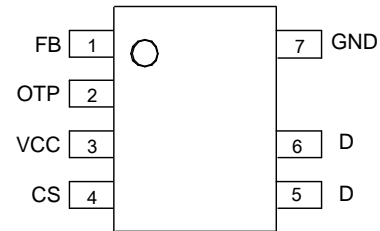

SO-7

## Features

- Primary-Side Control for Eliminating Opto-Coupler
- 10mW No-Load Input Power
- Built-In 650V High Performance MOSFET
- Flyback Topology in DCM Operation
- Built-In 0.35V Cable Compensation for CV
- Multiple PWM/PFM Control Mode to Improve Audio Noise and Efficiency
- VCS Jitter to Reduce System EMI
- Valley-On for the Higher Efficiency and Better EMI
- Multiple Protections:
  - Over Voltage Protection (OVP)
  - Output Short Circuit Protection (SCP)
  - Transformer Saturation Protection (TSP) via Primary Peak Current Limitation
  - Internal and External Over Temperature Protection (OTP)
- Matching AP4341 with Schottky or APR3415CT Series Synchronous Rectifier Solution
- SO-7 Package
- **Totally Lead-Free & Fully RoHS Compliant (Notes 1 & 2)**
- **Halogen and Antimony Free. “Green” Device (Note 3)**



**Functional Block Diagram**

NEW PRODUCT

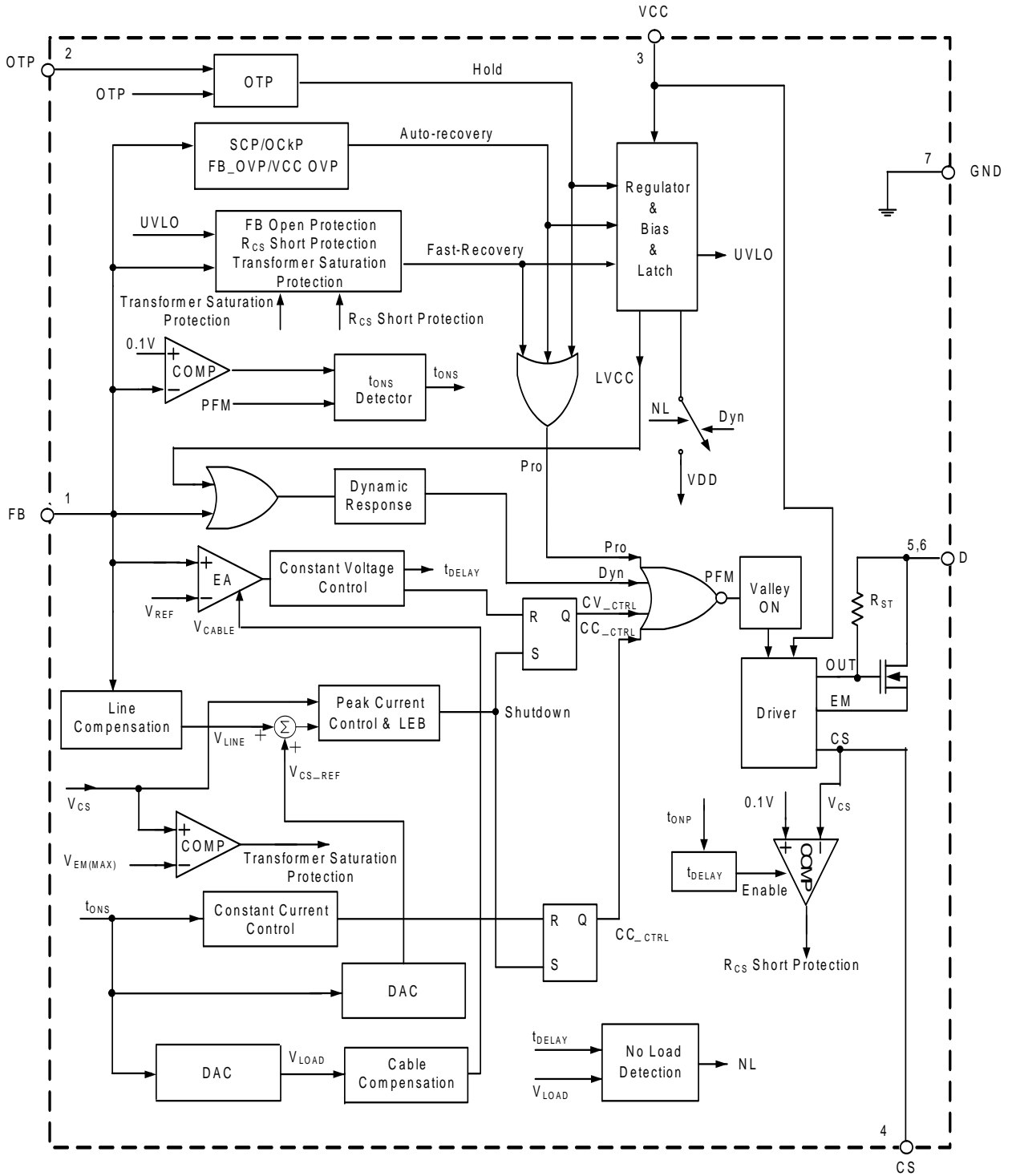

**Absolute Maximum Ratings** (Note 4)

Symbol	Parameter	Rating	Unit
V <sub>CC</sub>	Supply Voltage	-0.3 to 28.5	V
V <sub>CS</sub>	Voltage on CS Pin	-0.3 to 7.4	V
V <sub>FB</sub>	FB Input Voltage	-0.7 to 7.4	V
BV <sub>DSS</sub>	Drain Voltage (T <sub>J</sub> =+25°C)	650	V
I <sub>D</sub>	Drain Continuous Current (T <sub>J</sub> =+25°C)	2	A
T <sub>J</sub>	Operating Junction Temperature	-40 to +150	°C
T <sub>STG</sub>	Storage Temperature	-65 to +150	°C
T <sub>LEAD</sub>	Lead Temperature (Soldering, 10s)	+260	°C
—	ESD (Charge Device Model)	1000	V
—	ESD (Human Body Model)	2000	V
P <sub>D</sub>	Total Power Dissipation	1	W

Note: 4. Stresses greater than those listed under *Absolute Maximum Ratings* can cause permanent damage to the device. These are stress ratings only, and functional operation of the device at these or any other conditions beyond those indicated under *Recommended Operating Conditions* is not implied. Exposure to *Absolute Maximum Ratings* for extended periods can affect device reliability.

**Recommended Operating Conditions**

Symbol	Parameter	Min	Max	Unit
V <sub>CC</sub>	Supply Voltage	—	25	V
T <sub>OP</sub>	Operating Temperature Range	-40	+85	°C

**Thermal Impedance** (Note 5)

Symbol	Parameter	Value	Unit
θ <sub>JA</sub>	Junction to Ambient	92	°C/W

Note: 5. Test condition: Device mounted on FR-4 substrate PC board, 2oz copper, with 1inch<sup>2</sup> cooling area.

**Electrical Characteristics** (@V<sub>CC</sub>=15V, T<sub>J</sub>=+25°C, unless otherwise specified.) (Note 7)

Symbol	Parameter	Condition	Min	Typ	Max	Unit
<b>STARTUP AND UVLO SECTION</b>						
V <sub>TH_ST</sub>	Turn-On Voltage	—	11	13	15	V
V <sub>UVLO</sub>	Turn-Off Voltage	—	5.5	5.9	6.3	V
<b>STANDBY CURRENT SECTION</b>						
I <sub>ST</sub>	Turn-On Current	V <sub>CC</sub> =V <sub>TH_ST</sub> -1V before Startup	0.01	0.2	0.6	μA
I <sub>CC_OPR</sub>	Operating Current	Static Current	400	550	700	
I <sub>CC_NL</sub>	Standby Current	At No Load	5	17.5	30	
<b>FREQUENCY JITTER SECTION</b>						
ΔV <sub>CS</sub> /V <sub>CS</sub>	V <sub>CS</sub> Modulation	NL to Full Load	4.5	5	5.5	%
t <sub>MOD</sub>	V <sub>CS</sub> Modulation Period		366	488	610	μs
<b>CURRENT SENSE SECTION</b>						
V <sub>CS_H</sub>	Peak Current Sense Voltage Reference in Heavy Load	45% to 100% of Full Load (Note 8)	540	600	660	mV
V <sub>CS_L</sub>	Peak Current Sense Voltage Reference in Light Load	0% to 8% Full Load (Note 8)	225	250	275	mV
R <sub>LINE</sub>	Built-In Line Compensation Resistance	@CP (Note 9)	108	120	132	Ω
t <sub>LEB</sub>	Leading Edge Blanking	—	300	550	800	ns
<b>CONSTANT VOLTAGE SECTION</b>						
V <sub>FB</sub>	Feedback Threshold Voltage	Tested @75% of Maximum I <sub>OUT</sub>	2.505	2.556	2.607	V
V <sub>CABLE(MAX)</sub>	Cable Compensation Voltage	—	—	0.35	—	V
<b>CONSTANT CURRENT SECTION</b>						
t <sub>ONS</sub> /t <sub>SW</sub>	Secondary Winding Conduction Duty	Tested @V <sub>FB</sub> =2V	—	4/8	—	—
<b>VALLEY-ON SECTION</b>						
t <sub>VAL-ON</sub>	Valid Off Time of Valley-On	From the End of t <sub>ONS</sub>	20	27	34	μs
<b>DYNAMIC SECTION</b>						
V <sub>TRIGGER</sub>	Trigger Voltage for Dynamic Function	—	40	62.5	85	mV
t <sub>DELAY</sub>	Delay Time for Dynamic Function	From the End of t <sub>ONS</sub>	95	122	150	μs
V <sub>UV_H</sub>	Under Voltage of FB Pin for V <sub>CS_H</sub>	—	2.34	2.39	2.44	V
<b>POWER MOSFET SECTION</b>						
BV <sub>DSS</sub>	Drain-Source Breakdown Voltage (Note 6)	@CP Test	650	—	—	V
R <sub>DS(ON)</sub>	On State Resistance	@CP Test	—	4	—	Ω
<b>DRIVER SECTION</b>						
I <sub>SOURCE</sub>	Peak Driver Source Current	@CP Test	18	22	26	mA
<b>PROTECTION FUNCTION SECTION</b>						
V <sub>FB(OVP)</sub>	Over Voltage Protection at FB Pin	—	3.5	3.75	4	V
V <sub>CC(OVP)</sub>	Over Voltage Protection at VCC Pin	—	27	28.5	30	V
t <sub>ONP(MAX)</sub>	Maximum Turn-On Time	—	14	18	22	μs
V <sub>CS(MIN)</sub>	Minimum Peak Current Sense Voltage at t <sub>ONP(MAX)</sub>	—	135	150	165	mV
V <sub>EM(MAX)</sub>	Maximum EM Voltage for Transformer Saturation Protection (Note 10)	(Note 7)	1.8	2	2.2	V
V <sub>FB(SCP)</sub>	Short Circuit Protection	V <sub>FB</sub> @ Hiccup	1.83	1.87	1.92	V
t <sub>SCP</sub>	Time under V <sub>FB(SCP)</sub>	—	32	51.5	71	ms
V <sub>OTP</sub>	External OTP Shutdown Threshold	—	0.49	0.52	0.55	V
V <sub>OTP_REC</sub>	External OTP Recovery Threshold	—	0.58	0.62	0.66	V
I <sub>OTP</sub>	External OTP Shutdown Current	—	94	102	110	μA
T <sub>OTP</sub>	Shutdown Temperature	—	+135	+145	+155	°C
T <sub>HYS</sub>	Temperature Hysteresis	—	+37	+40	+43	°C

- Notes:
- The drain-source voltage is 80% of BV<sub>DSS</sub> in the aging condition.
  - These parameters are not 100% tested, guaranteed by design and characterization.
  - Peak current sense voltage reference without line compensation. 
$$\Delta V_{CS\_REF} = 0.35 \times \frac{R_{LINE}}{R_{FBI} + R_{LINE}} \times V_{AUX}$$
  - Line compensation voltage on CS reference.
  - EM is an internal pin which is connected to the source of power MOSFET inside.



**Operation Description** (continued)

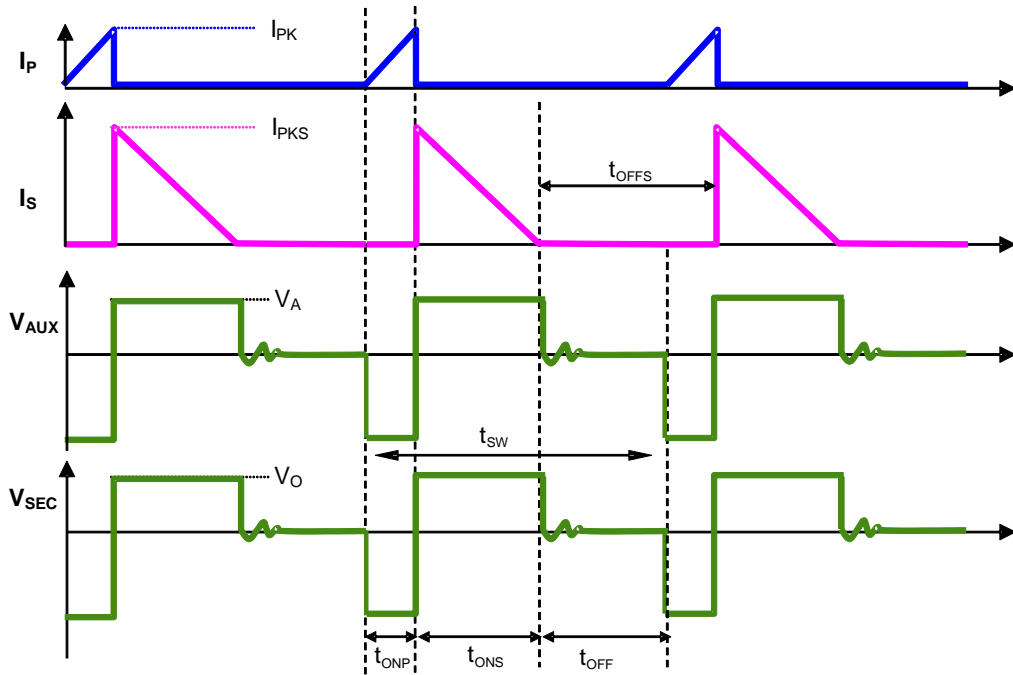

Figure 2. The Operation Waveform of Flyback PSR System

**3. Constant Voltage Operation**

As to Constant Voltage (CV) operation mode, the AP3987CT detects the auxiliary winding voltage at FB pin to regulate the output voltage. The auxiliary winding voltage is coupled with secondary side winding voltage, so the auxiliary winding voltage during t<sub>ONS</sub> is:

$$V_{AUX} = \frac{N_{AUX}}{N_S} \times (V_{OUT} + V_D) \quad (1)$$

Where V<sub>D</sub> is the conduction voltage drop of MOSFET in APR3415CT.

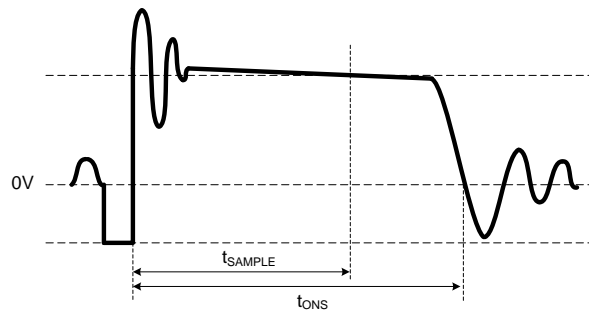

Figure 3. Auxiliary Voltage Waveform

The voltage detection point is at the t<sub>SAMPLE</sub> of t<sub>ONS</sub>. The voltage detection point is changed with the different primary peak current. The CV loop control function of AP3987CT then generates a t<sub>OFF</sub> to regulate the output voltage.

**4. Constant Current Operation**

The AP3987CT can work in Constant Current (CC) mode. Figure 2 shows the secondary current waveforms.

In CC operation mode, the CC control loop of AP3987CT will keep a fixed proportion between t<sub>ONS</sub> and t<sub>OFFS</sub>. The fixed proportion is

$$\frac{t_{ONS}}{t_{OFFS}} = \frac{4}{4} \quad (2)$$

**Operation Description** (continued)

The relationship between the output current and secondary peak current  $I_{PKS}$  is given by:

$$I_{OUT} = \frac{1}{2} \times I_{PKS} \times \frac{t_{ONS}}{t_{ONS} + t_{OFFS}} \quad (3)$$

As to tight coupled primary and secondary winding, the secondary peak current is

$$I_{PKS} = \frac{N_P}{N_S} \times I_{PK} \quad (4)$$

Thus the output constant current is given by:

$$I_{OUT} = \frac{1}{2} \times \frac{N_P}{N_S} \times I_{PK} \times \frac{t_{ONS}}{t_{ONS} + t_{OFFS}} = \frac{2}{8} \times \frac{N_P}{N_S} \times I_{PK} \quad (5)$$

Therefore, AP3987CT can realize CC mode operation by constant primary peak current and fixed secondary side conduction duty cycle.

**5. Multiple Segment Peak Current**

As to the original PFM PSR system, the switching frequency decreases with decreasing of output current, which will encounter audible noise issue since switching frequency decreases to audio frequency range, about less than 20kHz.

In order to avoid audible noise issue, AP3987CT uses 3-segment primary peak current control method at Constant Voltage (CV) mode, the current sense threshold voltages are multiple segments with different loading, as shown in Figure 4, which are  $V_{CS\_H}$  for high load, varied  $V_{CS\_M}$  for medium load and  $V_{CS\_L}$  for light load. In no load and ultra light load condition (NL mode), the current reference is also  $V_{CS\_L}$ . But the operation in NL mode is different, which will be described in next section.

At Constant Current (CC) mode, the peak current is still  $V_{CS\_H}$  when  $V_O > V_{FB(SCP)}$ . If not, the peak current is  $2/3 \times V_{CS\_H}$ .

It can be seen from the following figure that with multiple segment peak current control. The AP3987CT power system can keep switching frequency above 20kHz from light load to heavy load and guarantee the audible-noise-free performance, and the maximum load system switching frequency is not less than 50kHz, and no more than 70kHz.

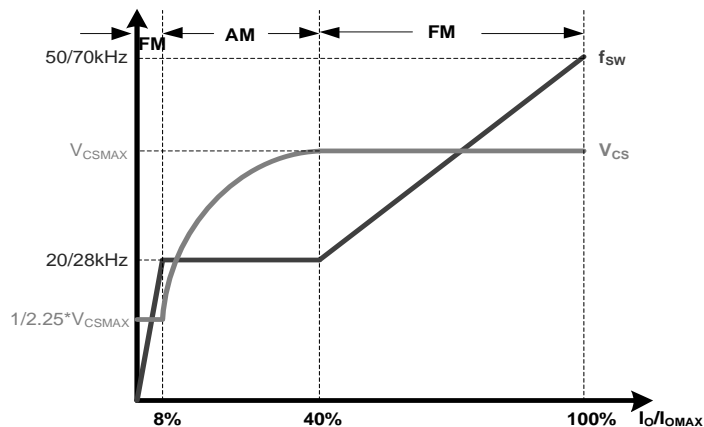

Figure 4. Segment Peak Current and Operating Frequency at CV Mode



## Operation Description (continued)

### 6. Operating Frequency

For primary-side regulation, the primary current  $i_p(t)$  is sensed by a current sense resistor  $R_{CS}$  ( $R_4$  as shown in Typical Applications). The current rises up linearly at a rate of:

$$\frac{di_p(t)}{dt} = \frac{V_{IN}(t)}{L_M} \quad (6)$$

As illustrated in Figure 2, when the current  $i_p(t)$  rises up to  $I_{PK}$ , the switch Q1 turns off. The constant peak current is given by:

$$I_{PK} = \frac{V_{CS}}{R_{CS}} \quad (7)$$

The energy stored in the magnetizing inductance  $L_M$  each cycle is therefore:

$$E_G = \frac{1}{2} \times L_M \cdot I_{PK}^2 \quad (8)$$

So the power transferring from the input to the output is given by:

$$P = \frac{1}{2} \times L_M \times I_{PK}^2 \times f_{SW} \quad (9)$$

$$\eta \times \frac{1}{2} \times L_P \times I_{PK}^2 \times f_{SW} = P_O = V_O \times I_O \quad (10)$$

Where,  $f_{SW}$  is the switching frequency,  $\eta$  is the transferring efficiency.

In AP3987CT, the high load mode and light load mode adopt the Frequency Modulation (FM), and the middle load mode uses the Amplitude Modulation (AM).

During FM, the peak current  $I_{PK}$  is constant, the output power depends on the switching frequency  $f_{SW}$ .

During AM, the frequency is fixed,  $V_{CS\_M}$  is varied. Below is the analysis of  $V_{CS\_M}$ .

The square root equation can be got from the following equation:

$$\eta \times \frac{1}{2} \times L_P \times I_{PK}^2 \times f_{SW} = \eta \times \frac{1}{2} \times L_P \times \left( \frac{V_{CS}}{R_{CS}} \right)^2 \times f_{SW} = V_O \times I_O \quad (11)$$

$$\text{So, } V_{CS} = \sqrt{\frac{2 \cdot R_{CS}^2 \cdot V_O \cdot I_O}{\eta \cdot L_P \cdot f_{SW}}} \quad (12)$$

During AM, the frequency is fixed, assume  $V_O$  and  $\eta$  are constants, then

$$V_{CS} = k \cdot \sqrt{I_O} \quad \left( k = \sqrt{\frac{2 \cdot R_{CS}^2 \cdot V_O}{\eta \cdot L_P \cdot f_{SW}}} \right) \quad (13)$$

### 7. NL Mode Operation (Typical Application with APR3415CT)

At no load and ultra light load, the AP3987CT works at No Load mode (NL mode) and the output voltage is detected by APR3415CT. In order to achieve ultra low standby power at NL mode, the static current is reduced to  $I_{CC\_NL}$ .

- The conditions of exiting NL mode--- $V_{CBC} > V_{CBC(EN)}$  or  $t_{OFF} < t_{OFF(EX)}$
- The conditions of entering NL mode--  $V_{CBC} < V_{CBC(EN)}$  and  $t_{OFF} \geq t_{OFF(EN)}$

At NL mode, the internal reference voltage  $V_{DD}$  is pulled to ground. For normal NL working state, when the APR3415CT detects the output voltage is lower than its trigger voltage, the APR3415CT VDET pin emits a periodical pulse current. This pulse current will generate a pulse voltage on feedback winding through the transformer coupling. When the FB pin detects this pulse ( $>V_{TRIGGER}$  is valid), the AP3987CT re-establishes the  $V_{DD}$  and turns on primary switch to provide one energy pulse to supply output terminal and primary VCC voltage.

**Operation Description** (continued)

**8. Leading Edge Blanking**

When the power switch is turned on, a turn-on spike will occur on the sense-resistor. To avoid false-termination of the switching pulse, a leading-edge blanking (from power MOSFET on) is built in. During this blanking period, the current sense comparator is disabled and the gate driver can't be switched off.

**9. Valley Turn-On**

When the off time ( $t_{OFF}$ ) is lower than  $t_{VAL-ON}$ , the AP3987CT power system can work with valley turn-on. It can reduce MOSFET switching on power losses which is resulted from the equivalent output capacitance to achieve highest overall efficiency. At the same time, because of valley turn-on the switching frequency has the random jitter feature, which will be benefit for conductive EMI performance. And valley turn-on can also reduce the power switch turn-on spike current and then achieve the better radiative EMI performance.

**10. Adjustable Line Compensation**

Since there is a constant delay time from the CS pin voltage reaching the given  $V_{CS}$  reference to the power switch turning off, the real primary peak current value always has a gap with the ideal value. The gap value changes with different input line voltage, which is caused by different current rising slope, and results in different system constant current value.

In order to eliminate the constant current deviation due to line voltage, the adjustable line compensation is introduced to the AP3987CT design. The negative voltage of FB pin which is linear to the line voltage is added up to  $V_{CS}$  reference by a certain proportion and creates an adjustable compensation voltage to clear up the primary current gap, so that the excellent line regulation of output current will be achieved.

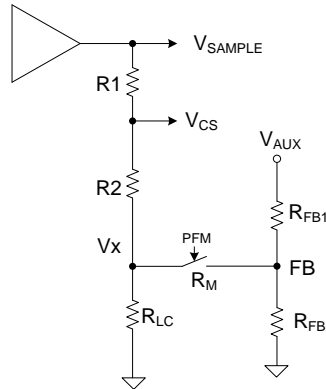

Figure 5. Adjustable Line Compensation Circuit

$$\Delta V_{CS} = - \frac{R_1}{R_1 + R_2} \cdot \frac{N_{AUX}}{N_P} \cdot \frac{R_{LC}}{R_{LC} + R_M + R_{FB1}} \cdot V_{LINE} \dots\dots(14)$$

So, the AP3987CT can change the line compensation capability by adjusting the upper resistor at FB pin ( $R_{FB1}$ ). Higher resistance means lower line compensation capability.

**11. Protection**

The AP3987CT has various built-in single point fault protection features: FB over voltage protection, VCC over voltage protection, output short circuit protection, FB open circuit protection, transformer saturation protection and current sense resistor fault (short or open) protection, over temperature protection. The fault conditions to trigger these protections are different and protection modes to enter are different after the protections are triggered.

**11.1 Protection Mode**

The AP3987CT has three protection modes: auto-recovery, fast-recovery and hold. The operation principles are different.

When VCC over voltage protection, FB over voltage protection, output short circuit protection are activated, the AP3987CT enters the auto-recovery mode. Once the AP3987CT enters the auto recovery mode, the device shuts down immediately and doesn't signal any pulse, the VCC static current is decreased from operating current  $I_{CC\_OPR}$  to standby current  $I_{CC\_NL}$ . Until VCC voltage drops to  $V_{OPR(MIN)}$ , the AP3987CT will enter the restart process, and VCC voltage changes between  $V_{TH(ST)}$  and  $V_{OPR(MIN)}$  until the fault condition is removed. The slope of VCC voltage to discharge is very small, and the time to drop to  $V_{OPR(MIN)}$  is very long. It can decrease the average power dissipation at a fault condition.

**Operation Description** (continued)

When FB open circuit protection, transformer saturation protection and current sense resistor fault (short or open) protection are triggered the device enters the fast recovery mode. The only difference with auto recovery is that the VCC discharge current is kept operating current  $I_{CC\_OPR}$  and the system can fast restart.

When internal or external over temperature protection is activated, the device enters the hold mode. Once the hold mode is triggered, the AP3987CT doesn't signal any pulse until the fault condition is removed, and VCC Voltage is hold not lower than LVCC voltage.

**11.2 Short Circuit Protection (SCP)**

The Short Circuit Protection (SCP) detection principle is similar to the normal output voltage feedback detection by sensing FB pin voltage. When the detected FB pin voltage is below  $V_{FB(SCP)}$  for a duration of about  $t_{SCP}$ , the SCP is triggered. Then the AP3987CT enters hiccup mode that the IC immediately shuts down and then restarts, so that the VCC voltage changes between  $V_{TH\_ST}$  and UVLO threshold until  $V_{FB(SCP)}$  condition is removed.

As to the normal system startup, the time duration of FB pin voltage below  $V_{FB(SCP)}$  should be less than  $t_{SCP}$  to avoid entering SCP mode. But for the output short condition or the output voltage below a certain level, the SCP mode should happen.

Figure 6 is the AP3987CT normal start-up waveform that the voltage of FB pin is above  $V_{FB(SCP)}$  during  $t_{SCP}$  after  $V_{CC}$  gets to the  $V_{TH\_ST}$ , which doesn't enter the SCP mode. As shown in Figure 7,  $V_{OUT}$  is short and the voltage of FB pin is lower than  $V_{FB(SCP)}$  during  $t_{SCP}$ , the AP3987CT triggers the SCP and enters hiccup mode.

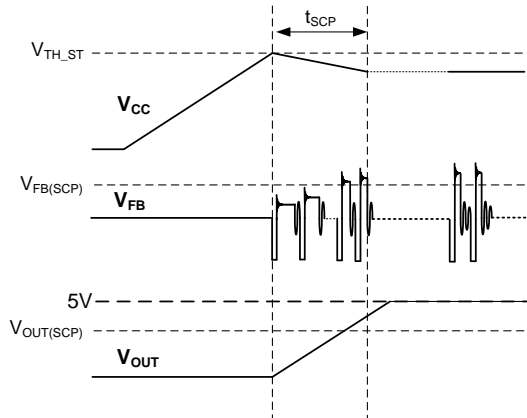

Figure 6. Normal Start-up

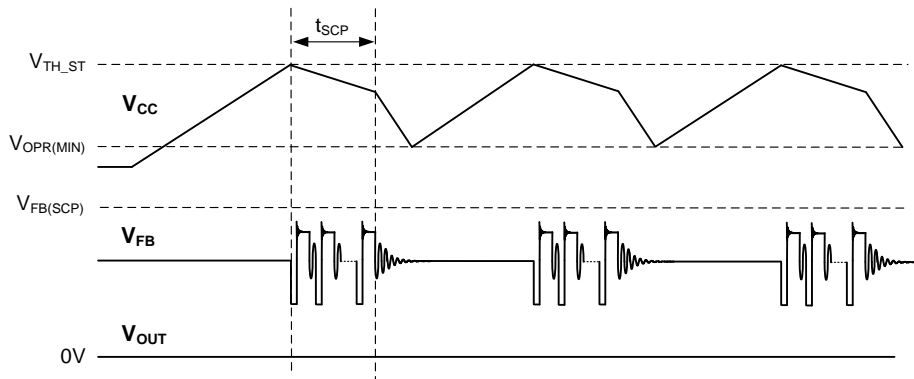

Figure 7. Short Circuit Protection (SCP) and Hiccup Mode

**11.3 Transformer Saturation Protection via Primary Peak Current Limitation**

When the transformer saturation happens, the voltage of EM pin (internal pin) will increase promptly and be over the reference voltage  $V_{EM(MAX)}$ . If two consecutive pulses exceed the value, the device shuts down and enters into auto-recovery mode.

## Operation Description (continued)

### 11.4 Internal Over Temperature Protection (Internal OTP)

If the IC junction temperature exceeds the threshold  $T_{OTP}$ , the AP3987CT shuts down immediately and enters the hold mode. If the junction temperature decreases by hysteresis temperature  $T_{HYS}$ , the AP3987CT can recover to normal operation. If not, the power system keeps the hold mode.

### 11.5 External Over Temperature Protection (External OTP)

The AP3987CT provides external Over Temperature Protection (OTP) by connecting a Negative Temperature Coefficient (NTC) resistor from OTP pin to GND. Internally, a current source  $I_{OTP}$  is injected to the OTP pin, which generates a voltage proportional to the NTC resistance. At high ambient temperature, the NTC resistance gets lower and results in the OTP pin voltage decreasing. If the OTP pin voltage drops below an internally-set threshold  $V_{OTP}$ , then the OTP is triggered, and the AP3987CT shuts down immediately and enters the fast auto recovery mode. The power system will keep fast auto recovery mode until the ambient temperature decreases and OTP pin voltage increases over the voltage  $V_{OTP\_REC}$ , which the AP3987CT can recover to normal operation.

If the OTP pin is not connected to the NTC resistor, the external OTP function will not work and the IC can still work normally with internal OTP.

## Ordering Information

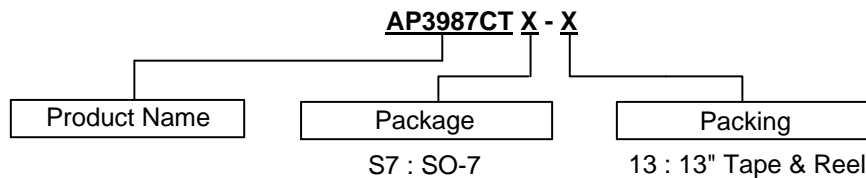

Package	Temperature Range	Part Number	Marking ID	13" Tape and Reel	
				Quantity	Part Number Suffix
SO-7	-40°C to +85°C	AP3987CTS7-13	AP3987CT	4000/Tape and Reel	-13

## Marking Information

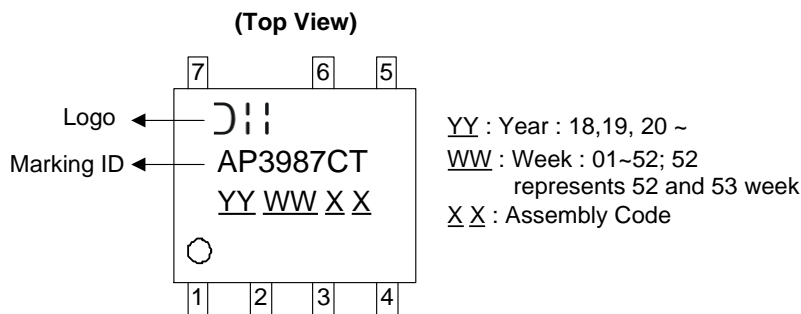

**Package Outline Dimensions** (All dimensions in mm(inch).)

Please see <http://www.diodes.com/package-outlines.html> for the latest version.

(1) Package Type: SO-7

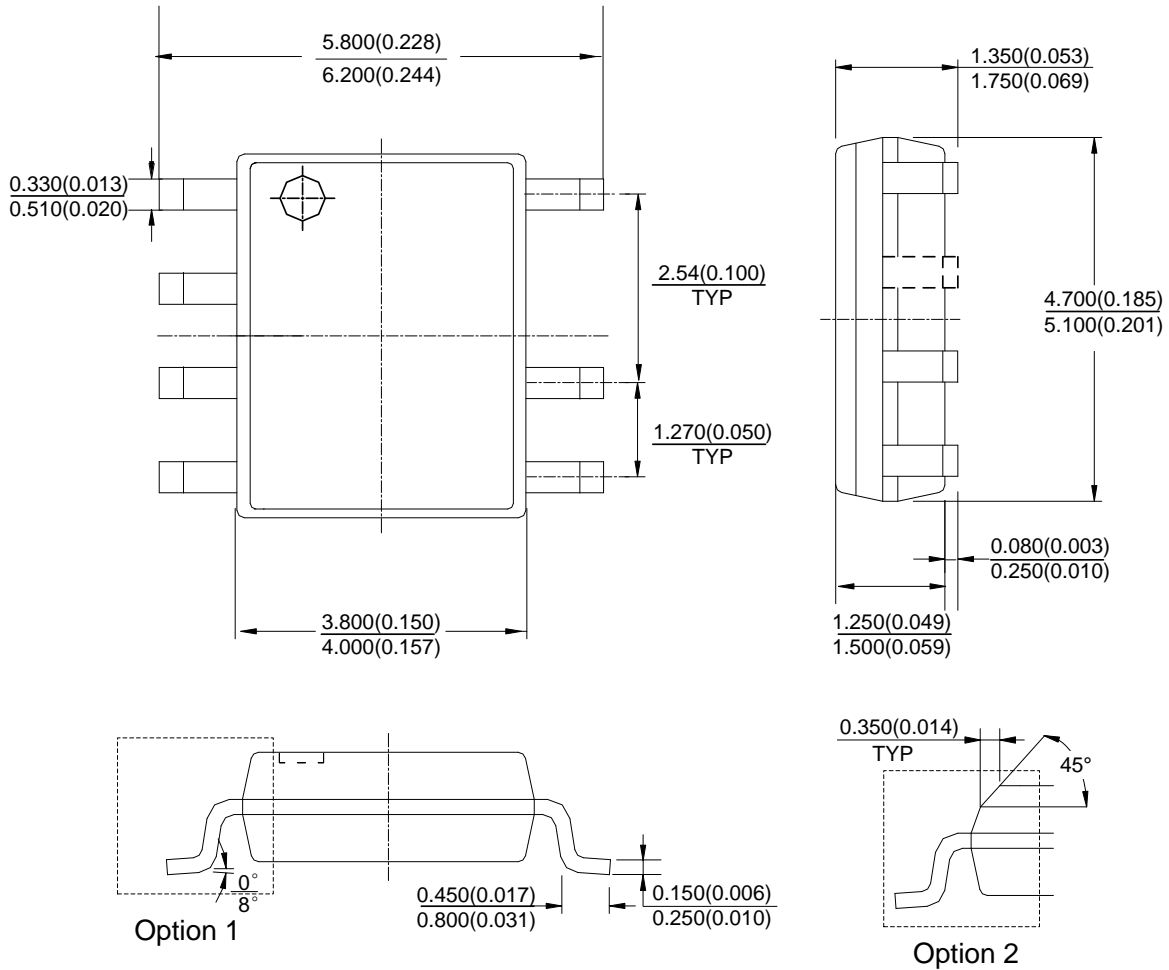

Note: Eject hole, oriented hole and mold mark is optional.

NEW PRODUCT

**Suggested Pad Layout**

Please see <http://www.diodes.com/package-outlines.html> for the latest version.

(1) Package Type: SO-7

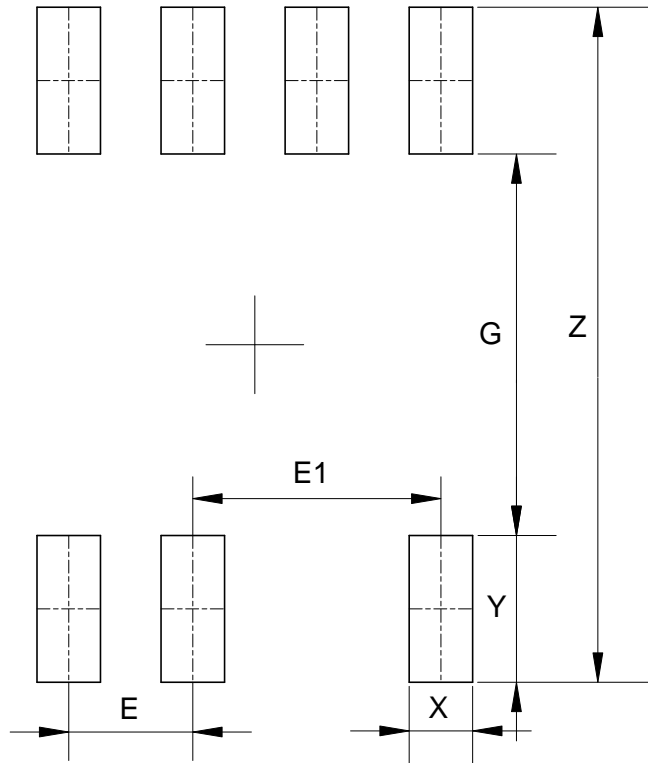

Dimensions	Z (mm)/(inch)	G (mm)/(inch)	X (mm)/(inch)	Y (mm)/(inch)	E (mm)/(inch)	E1 (mm)/(inch)
Value	6.900/0.272	3.900/0.154	0.650/0.026	1.500/0.059	1.270/0.050	2.540/0.100

NEW PRODUCT

**IMPORTANT NOTICE**

DIODES INCORPORATED MAKES NO WARRANTY OF ANY KIND, EXPRESS OR IMPLIED, WITH REGARDS TO THIS DOCUMENT, INCLUDING, BUT NOT LIMITED TO, THE IMPLIED WARRANTIES OF MERCHANTABILITY AND FITNESS FOR A PARTICULAR PURPOSE (AND THEIR EQUIVALENTS UNDER THE LAWS OF ANY JURISDICTION).

Diodes Incorporated and its subsidiaries reserve the right to make modifications, enhancements, improvements, corrections or other changes without further notice to this document and any product described herein. Diodes Incorporated does not assume any liability arising out of the application or use of this document or any product described herein; neither does Diodes Incorporated convey any license under its patent or trademark rights, nor the rights of others. Any Customer or user of this document or products described herein in such applications shall assume all risks of such use and will agree to hold Diodes Incorporated and all the companies whose products are represented on Diodes Incorporated website, harmless against all damages.

Diodes Incorporated does not warrant or accept any liability whatsoever in respect of any products purchased through unauthorized sales channel. Should Customers purchase or use Diodes Incorporated products for any unintended or unauthorized application, Customers shall indemnify and hold Diodes Incorporated and its representatives harmless against all claims, damages, expenses, and attorney fees arising out of, directly or indirectly, any claim of personal injury or death associated with such unintended or unauthorized application.

Products described herein may be covered by one or more United States, international or foreign patents pending. Product names and markings noted herein may also be covered by one or more United States, international or foreign trademarks.

This document is written in English but may be translated into multiple languages for reference. Only the English version of this document is the final and determinative format released by Diodes Incorporated.

**LIFE SUPPORT**

Diodes Incorporated products are specifically not authorized for use as critical components in life support devices or systems without the express written approval of the Chief Executive Officer of Diodes Incorporated. As used herein:

A. Life support devices or systems are devices or systems which:

1. are intended to implant into the body, or
2. support or sustain life and whose failure to perform when properly used in accordance with instructions for use provided in the labeling can be reasonably expected to result in significant injury to the user.

B. A critical component is any component in a life support device or system whose failure to perform can be reasonably expected to cause the failure of the life support device or to affect its safety or effectiveness.

Customers represent that they have all necessary expertise in the safety and regulatory ramifications of their life support devices or systems, and acknowledge and agree that they are solely responsible for all legal, regulatory and safety-related requirements concerning their products and any use of Diodes Incorporated products in such safety-critical, life support devices or systems, notwithstanding any devices- or systems-related information or support that may be provided by Diodes Incorporated. Further, Customers must fully indemnify Diodes Incorporated and its representatives against any damages arising out of the use of Diodes Incorporated products in such safety-critical, life support devices or systems.

Copyright © 2019, Diodes Incorporated

[www.diodes.com](http://www.diodes.com)