

TVS Diode

Transient Voltage Suppressor Diode

ESD5V3U4U-HDMI

Uni-directional Ultra-low Capacitance ESD / Transient Protection Array

ESD5V3U4U-HDMI

Data Sheet

Revision 1.0, 2011-06-30
Final

Industrial and Multi-Market

Edition 2011-06-30

**Published by
Infineon Technologies AG
81726 Munich, Germany**

**© 2011 Infineon Technologies AG
All Rights Reserved.**

Legal Disclaimer

The information given in this document shall in no event be regarded as a guarantee of conditions or characteristics. With respect to any examples or hints given herein, any typical values stated herein and/or any information regarding the application of the device, Infineon Technologies hereby disclaims any and all warranties and liabilities of any kind, including without limitation, warranties of non-infringement of intellectual property rights of any third party.

Information

For further information on technology, delivery terms and conditions and prices, please contact the nearest Infineon Technologies Office (www.infineon.com).

Warnings

Due to technical requirements, components may contain dangerous substances. For information on the types in question, please contact the nearest Infineon Technologies Office.

Infineon Technologies components may be used in life-support devices or systems only with the express written approval of Infineon Technologies, if a failure of such components can reasonably be expected to cause the failure of that life-support device or system or to affect the safety or effectiveness of that device or system. Life support devices or systems are intended to be implanted in the human body or to support and/or maintain and sustain and/or protect human life. If they fail, it is reasonable to assume that the health of the user or other persons may be endangered.

Revision History

Page or Item	Subjects (major changes since previous revision)
Revision 1.0, 2011-06-30	
all	data sheet conversion to Framemaker template

Trademarks of Infineon Technologies AG

AURIX™, BlueMoon™, C166™, CanPAK™, CIPOS™, CIPURSE™, COMNEON™, EconoPACK™, CoolMOS™, CoolSET™, CORECONTROL™, CROSSAVE™, DAVE™, EasyPIM™, EconoBRIDGE™, EconoDUAL™, EconoPIM™, EiceDRIVER™, eupec™, FCOS™, HITFET™, HybridPACK™, I²RF™, ISOFACE™, IsoPACK™, MIPAQ™, ModSTACK™, my-d™, NovalithIC™, OmniTune™, OptiMOS™, ORIGA™, PRIMARION™, PrimePACK™, PrimeSTACK™, PRO-SIL™, PROFET™, RASIC™, ReverSave™, SatRIC™, SIEGET™, SINDRION™, SIPMOS™, SMARTi™, SmartLEWIS™, SOLID FLASH™, TEMPFET™, thinQ!™, TRENCHSTOP™, TriCore™, X-GOLD™, X-PMU™, XMM™, XPOSYS™.

Other Trademarks

Advance Design System™ (ADS) of Agilent Technologies, AMBA™, ARM™, MULTI-ICE™, KEIL™, PRIMECELL™, REALVIEW™, THUMB™, μVision™ of ARM Limited, UK. AUTOSAR™ is licensed by AUTOSAR development partnership. Bluetooth™ of Bluetooth SIG Inc. CAT-iq™ of DECT Forum. COLOSSUS™, FirstGPS™ of Trimble Navigation Ltd. EMV™ of EMVCo, LLC (Visa Holdings Inc.). EPCOS™ of Epcos AG. FLEXGO™ of Microsoft Corporation. FlexRay™ is licensed by FlexRay Consortium. HYPERTERMINAL™ of Hilgraeve Incorporated. IEC™ of Commission Electrotechnique Internationale. IrDA™ of Infrared Data Association Corporation. ISO™ of INTERNATIONAL ORGANIZATION FOR STANDARDIZATION. MATLAB™ of MathWorks, Inc. MAXIM™ of Maxim Integrated Products, Inc. MICROTEC™, NUCLEUS™ of Mentor Graphics Corporation. Mifare™ of NXP. MIPI™ of MIPI Alliance, Inc. MIPS™ of MIPS Technologies, Inc., USA. muRata™ of MURATA MANUFACTURING CO., MICROWAVE OFFICE™ (MWO) of Applied Wave Research Inc., OmniVision™ of OmniVision Technologies, Inc. Openwave™ Openwave Systems Inc. RED HAT™ Red Hat, Inc. RFMD™ RF Micro Devices, Inc. SIRIUS™ of Sirius Satellite Radio Inc. SOLARIS™ of Sun Microsystems, Inc. SPANSION™ of Spansion LLC Ltd. Symbian™ of Symbian Software Limited. TAIYO YUDEN™ of Taiyo Yuden Co. TEAKLITE™ of CEVA, Inc. TEKTRONIX™ of Tektronix Inc. TOKO™ of TOKO KABUSHIKI KAISHA TA. UNIX™ of X/Open Company Limited. VERILOG™, PALLADIUM™ of Cadence Design Systems, Inc. VLYNQ™ of Texas Instruments Incorporated. VXWORKS™, WIND RIVER™ of WIND RIVER SYSTEMS, INC. ZETEX™ of Diodes Zetex Limited.

Last Trademarks Update 2010-10-26

Table of Contents

	Table of Contents	4
	List of Figures	5
	List of Tables	6
	Predefined Names	7
1	Uni-directional Ultra-low Capacitance ESD / Transient Protection Array	8
1.1	Features	8
1.2	Application Examples	8
2	Product Description	8
3	Characteristics	9
3.1	Electrical Characteristics at $T_A = 25\text{ °C}$, unless otherwise specified	9
3.2	Typical Characteristics at $T_A = 25\text{ °C}$, unless otherwise specified	11
4	Application Information	16
5	Ordering Information Scheme (Examples)	17
6	Package Information	18
6.1	PG-TSLP-9-1	18
	References	20
	Terminology	21

List of Figures

Figure 2-1	Pin Configuration and Schematic Diagram	8
Figure 3-1	Definitions of Electrical Characteristics	9
Figure 3-2	Reverse current: $I_R = f(T_A)$, $V_R = 5.3$ V, (I/O to GND)	11
Figure 3-3	Diode capacitance: $C_L = f(V_R)$, (I/O to GND)	11
Figure 3-4	Line capacitance: $C_L = f(T_A)$	12
Figure 3-5	Line capacitance: $C_L = f(f)$, (I/O to GND)	12
Figure 3-6	Forward clamping voltage: $I_{TLP} = f(V_{TLP})$, (GND to I/O) [1]	13
Figure 3-7	Reverse clamping voltage: $I_{TLP} = f(V_{TLP})$, (I/O to GND) [1]	13
Figure 3-8	IEC61000-4-2 $V_{CL} = f(t)$, 8 kV positive pulse, (I/O to GND)	14
Figure 3-9	IEC61000-4-2 $V_{CL} = f(t)$, 8 kV negative pulse, (I/O to GND)	14
Figure 3-10	IEC61000-4-2 $V_{CL} = f(t)$, 15 kV positive pulse, (I/O to GND)	15
Figure 3-11	IEC61000-4-2 $V_{CL} = f(t)$, 15 kV negative pulse, (I/O to GND)	15
Figure 4-1	4 lines, uni-directional ESD5V3U4U-HDMI	16
Figure 5-1	Ordering information scheme	17
Figure 6-1	PG-TSLP-9-1: Package overview	18
Figure 6-2	PG-TSLP-9-1: Footprint	18
Figure 6-3	PG-TSLP-9-1: Packing	19
Figure 6-4	PG-TSLP-9-1: Marking (example)	19

List of Tables

Table 2-1	Ordering information	8
Table 3-1	Maximum Rating at $T_A = 25\text{ °C}$, unless otherwise specified	9
Table 3-2	DC Characteristics at $T_A = 25\text{ °C}$, unless otherwise specified	9
Table 3-3	RF Characteristics at $T_A = 25\text{ °C}$, unless otherwise specified	10
Table 3-4	ESD Characteristics at $T_A = 25\text{ °C}$, unless otherwise specified	10

Predefined Names

Name	Initial Cross-Reference
X-GOLD	X-GOLD
XMM	XMM

Definition of “Predefined Names”

Frequently used expressions, such as component names, file names, tools releases, version numbers, proprietary variables and software links, can be used in a similar way as user variables. However, they must be listed in a special table and **not** in the standard file “Variables”.

Correct Usage

Steps:

1. Insert all expressions into the left column of the above table.
2. Insert an initial Cross-Reference into the right column of the same row. The initial Cross-Reference is necessary to ensure that a single ID is used in all your documents using the “Predefined_Names.fm” file (Example: **X-GOLD** has the unique ID = CHDGHJGH).
3. Insert a Cross-Reference (Element “CrossReference”) into your document to the Element Identifier of the “Predefined_Names.fm” file. Set the output format of the Cross-Reference to “Variable” (example: X-GOLD).

Notes

1. All documents in a project (such as XMM) and within a book should use the same file “Predefined Names”. This allows copying content between different documents. For this reason, local versions of “Predefined Names” must not be produced.
2. New definitions must be inserted in a new row. Never change existing definitions, as they might be used in other documents.
3. This file does not need to be included in your book, but it must be in the fm sub-folder of your document.
4. You can sort the above table with FrameMaker only if the initial cross-reference in the right column has been properly inserted. Otherwise, the table may only be sorted by hand, as the cross-references to your document would get lost.

1 Uni-directional Ultra-low Capacitance ESD / Transient Protection Array

1.1 Features

- ESD / Transient protection of high speed data lines exceeding:
 - IEC61000-4-2 (ESD): ± 20 kV (air / contact)
 - IEC61000-4-4 (EFT): 2.5 kV / 50 A (5/50 ns)
 - IEC61000-4-5 (surge): 3 A (8/20 μ s)
- Maximum working voltage: $V_R = 5.3$ V
- Very low reverse current: $I_R < 1$ nA typ.
- Extremely low capacitance: 0.4 pF typ. (I/O to GND)
- Four-lines protection array with pad pitch = 0.5 mm
- Flow-through design for optimal PCB layout of differential lines
- Pb-free package (RoHS compliant) and halogen free package



1.2 Application Examples

- Protection of high speed digital interfaces like:
- HDMI 1.3, HDMI 1.4a, MHL, DisplayPort, S-ATA, DVI, MIPI, MDDI
- USB2.0, 10/100/1000 Ethernet, FireWire

2 Product Description

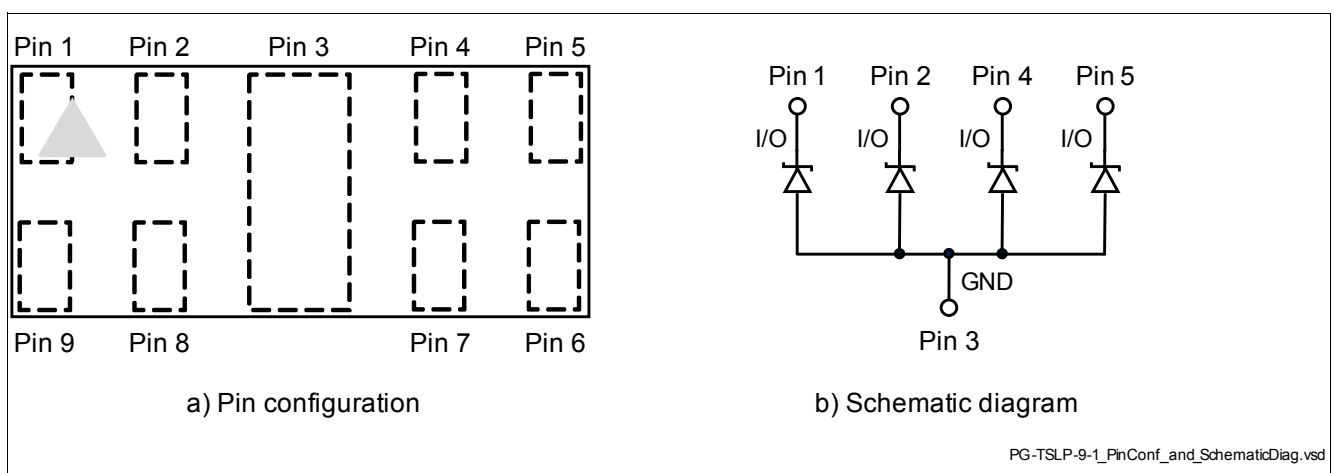

Figure 2-1 Pin Configuration and Schematic Diagram

Table 2-1 Ordering information

Type	Package	Configuration	Marking code
ESD5V3U4U-HDMI	PG-TSLP-9-1	4 lines, uni-directional	Z1

3 Characteristics

Table 3-1 Maximum Rating at $T_A = 25\text{ }^\circ\text{C}$, unless otherwise specified

Parameter	Symbol	Values			Unit
		Min.	Typ.	Max.	
ESD (air / contact) discharge ¹⁾	V_{ESD}	–	–	20	kV
Peak pulse current ($t_p = 8/20\text{ }\mu\text{s}$) ²⁾	I_{PP}	–	–	3	A
Operating temperature range	T_{OP}	-40	–	125	$^\circ\text{C}$
Storage temperature	T_{stg}	-65	–	150	$^\circ\text{C}$

1) V_{ESD} according to IEC61000-4-2

2) I_{PP} according to IEC61000-4-5

3.1 Electrical Characteristics at $T_A = 25\text{ }^\circ\text{C}$, unless otherwise specified

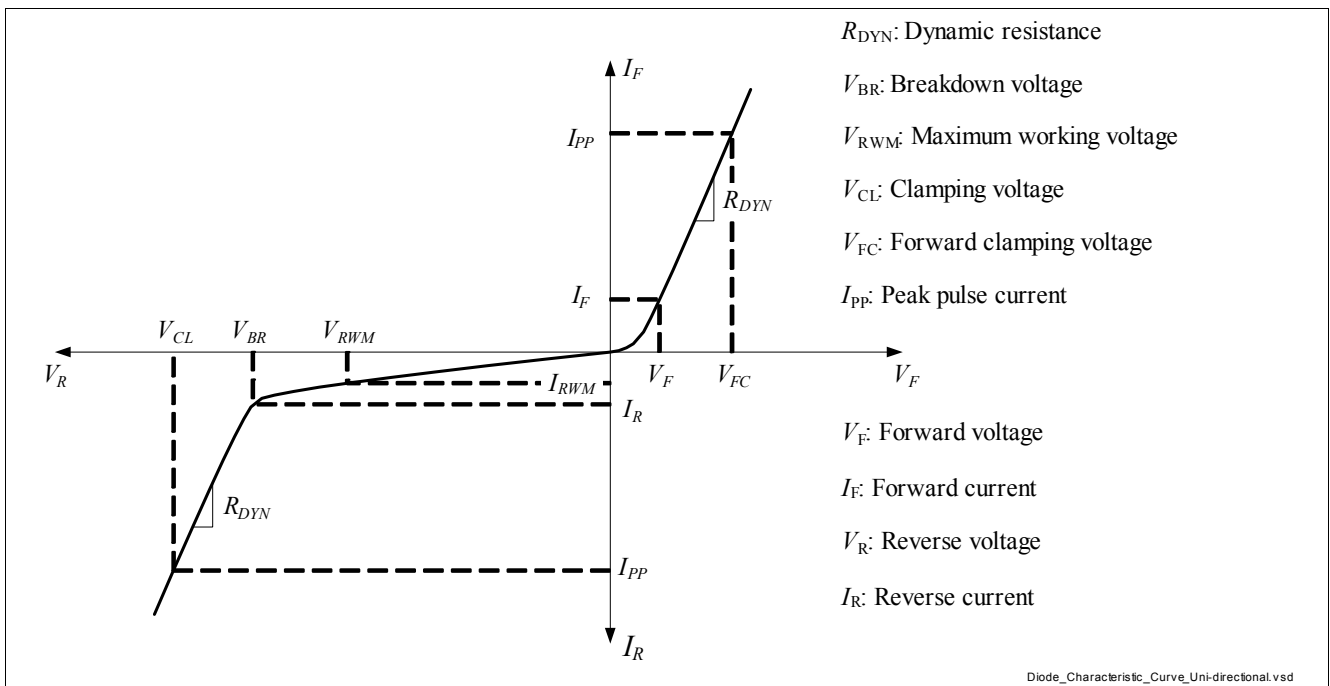

Figure 3-1 Definitions of Electrical Characteristics

Table 3-2 DC Characteristics at $T_A = 25\text{ }^\circ\text{C}$, unless otherwise specified

Parameter	Symbol	Values			Unit	Note / Test Condition
		Min.	Typ.	Max.		
Reverse working voltage	V_{RWM}	–	–	5.3	V	
Breakdown voltage	V_{BR}	6	–	–	V	$I_{BR} = 1\text{ mA}$ (I/O to GND)
Reverse current	I_R	–	<1	50	nA	$V_R = 5.3\text{ V}$ (I/O to GND)

Characteristics
Table 3-3 RF Characteristics at $T_A = 25\text{ }^\circ\text{C}$, unless otherwise specified

Parameter	Symbol	Values			Unit	Note / Test Condition
		Min.	Typ.	Max.		
Line capacitance ¹⁾	C_L	–	0.4	0.6	pF	$V_R = 0\text{ V}$, $f = 1\text{ MHz}$ (I/O to GND)
Line capacitance ¹⁾	C_L	–	0.2	0.3	pF	$V_R = 0\text{ V}$, $f = 1\text{ MHz}$ (I/O to I/O)

1) Total capacitance line to ground

Table 3-4 ESD Characteristics at $T_A = 25\text{ }^\circ\text{C}$, unless otherwise specified

Parameter	Symbol	Values			Unit	Note / Test Condition
		Min.	Typ.	Max.		
Clamping voltage ¹⁾	V_{CL}	–	19	–	V	$I_{PP} = 16\text{ A}$ (I/O to GND)
		–	28	–	V	$I_{PP} = 30\text{ A}$ (I/O to GND)
Forward clamping voltage ¹⁾	V_{FC}	–	10	–	V	$I_{PP} = 16\text{ A}$ (GND to I/O)
		–	17	–	V	$I_{PP} = 30\text{ A}$ (GND to I/O)
Dynamic resistance ¹⁾	R_{DYN}	–	0.6	–	Ω	I/O to GND
		–	0.5	–		GND to I/O

1) Please refer to Application Note AN210 [1]. TLP parameter: $Z_0 = 50\ \Omega$, $t_p = 100\text{ ns}$, $t_r = 300\text{ ps}$, averaging window: $t_1 = 30\text{ ns}$ to $t_2 = 60\text{ ns}$, extraction of dynamic resistance using least squares fit of TLP characteristic between $I_{PP1} = 10\text{ A}$ and $I_{PP2} = 40\text{ A}$.

3.2 Typical Characteristics at $T_A = 25^\circ\text{C}$, unless otherwise specified

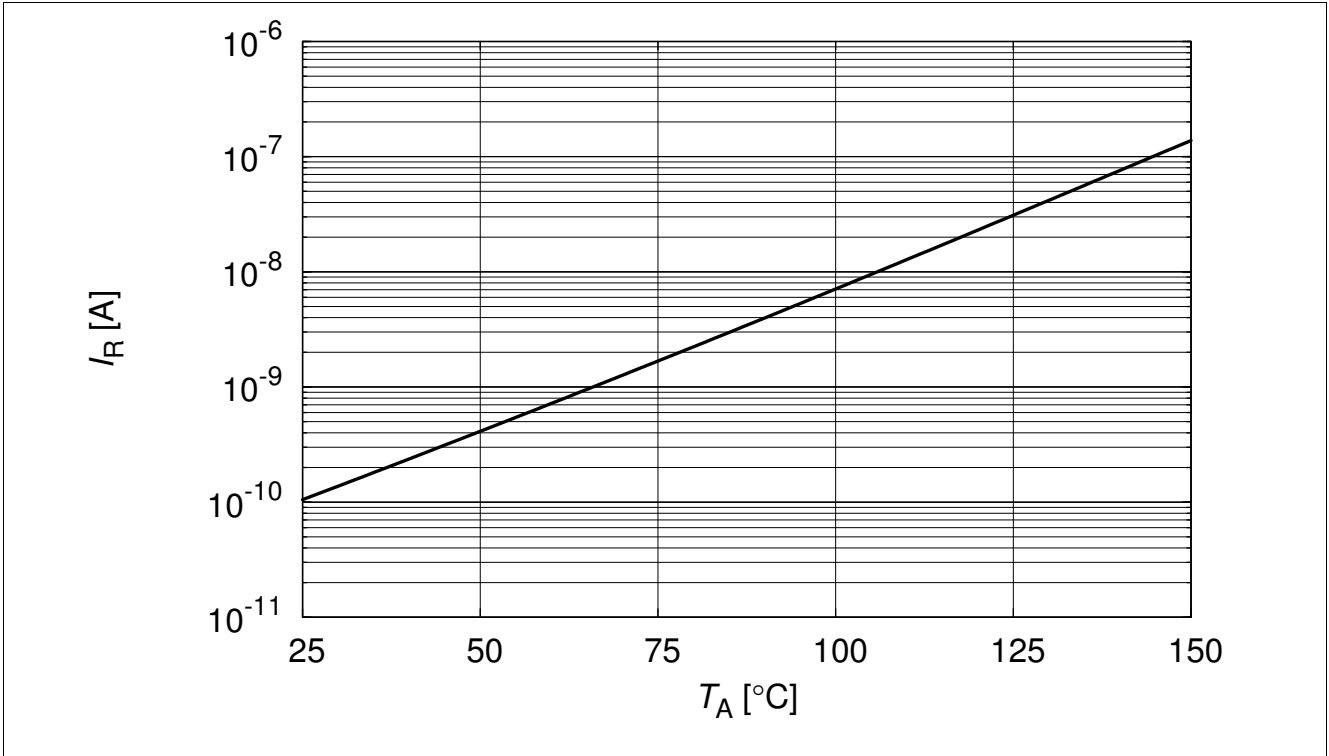

Figure 3-2 Reverse current: $I_R = f(T_A)$, $V_R = 5.3 \text{ V}$, (I/O to GND)

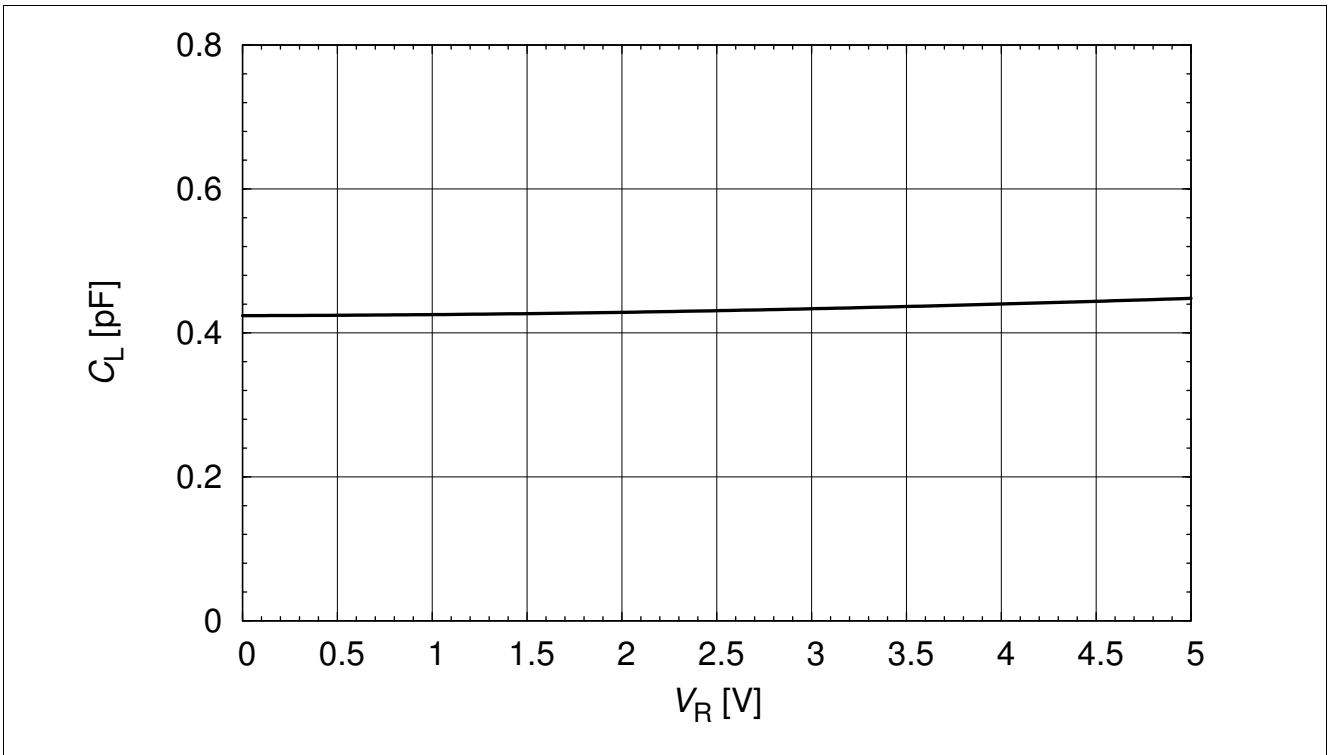

Figure 3-3 Diode capacitance: $C_L = f(V_R)$, (I/O to GND)

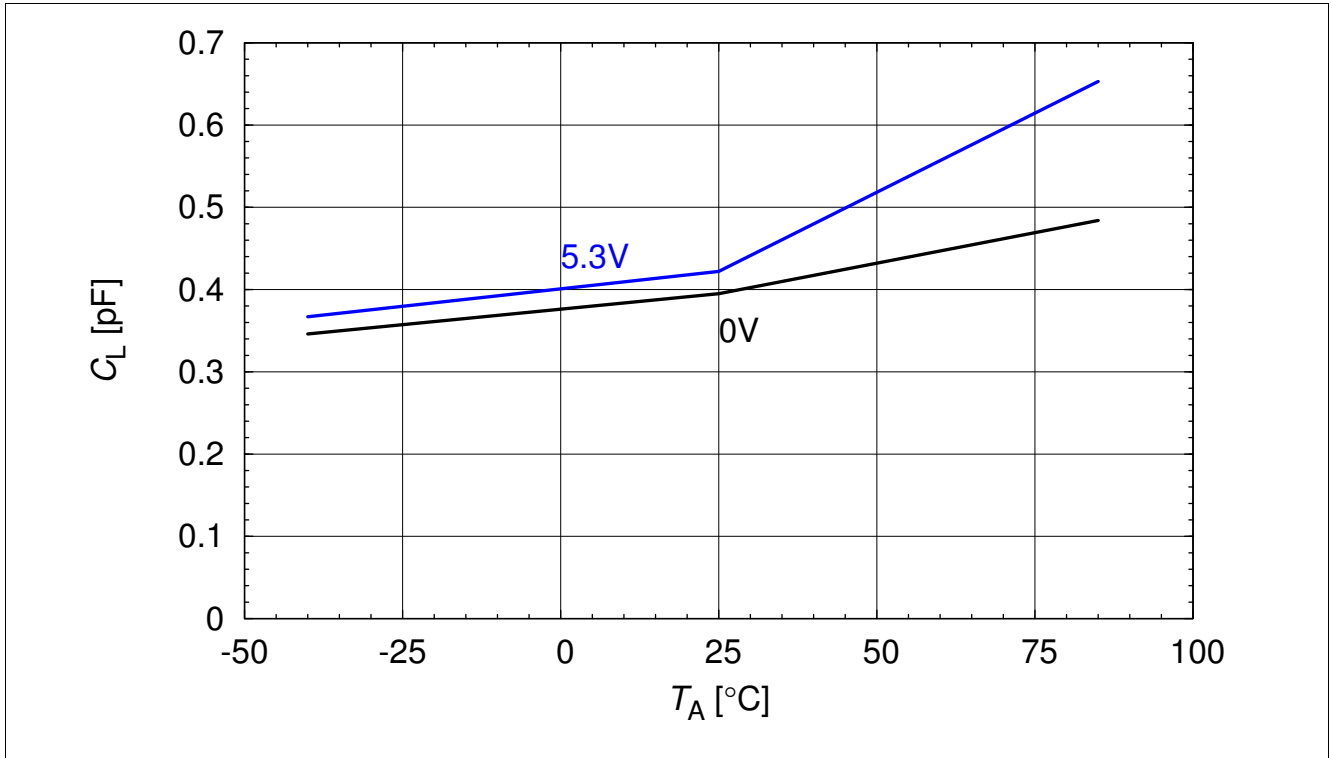

Figure 3-4 Line capacitance: $C_L = f(T_A)$

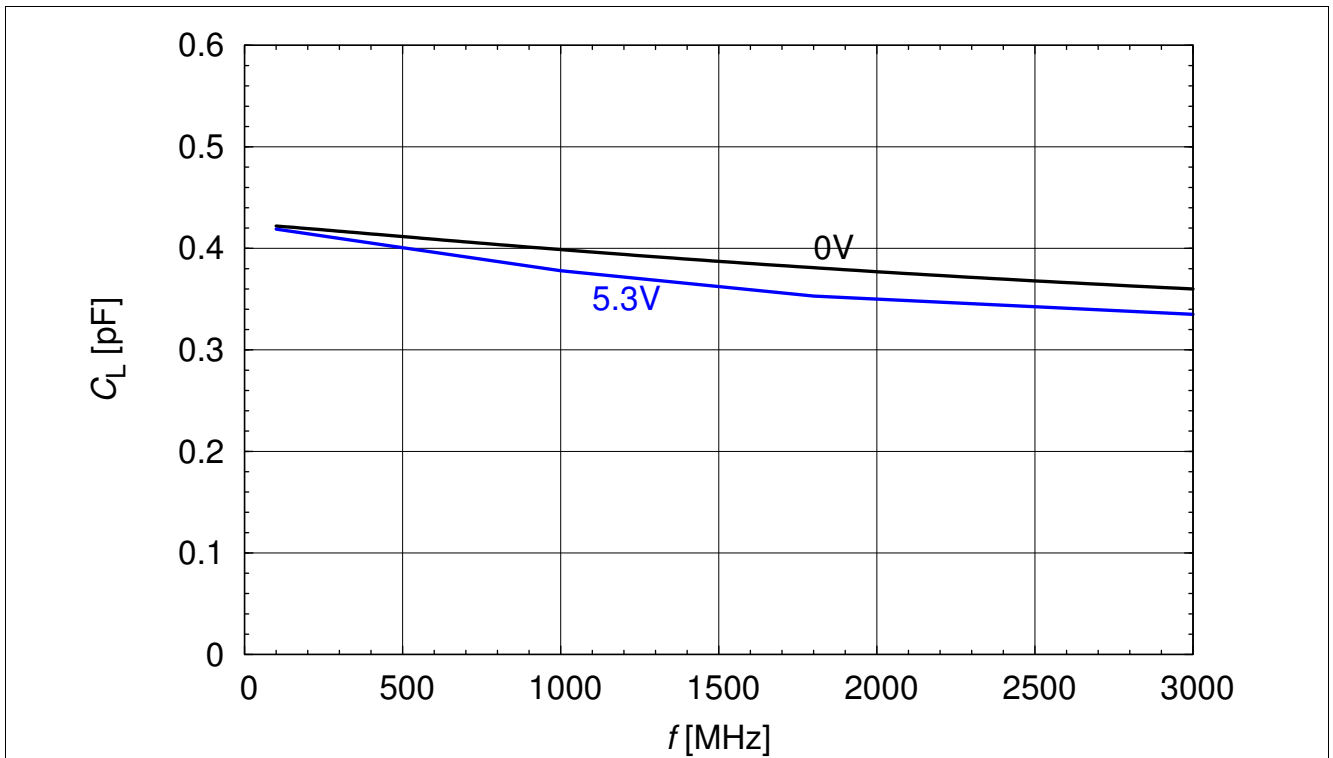

Figure 3-5 Line capacitance: $C_L = f(f)$, (I/O to GND)

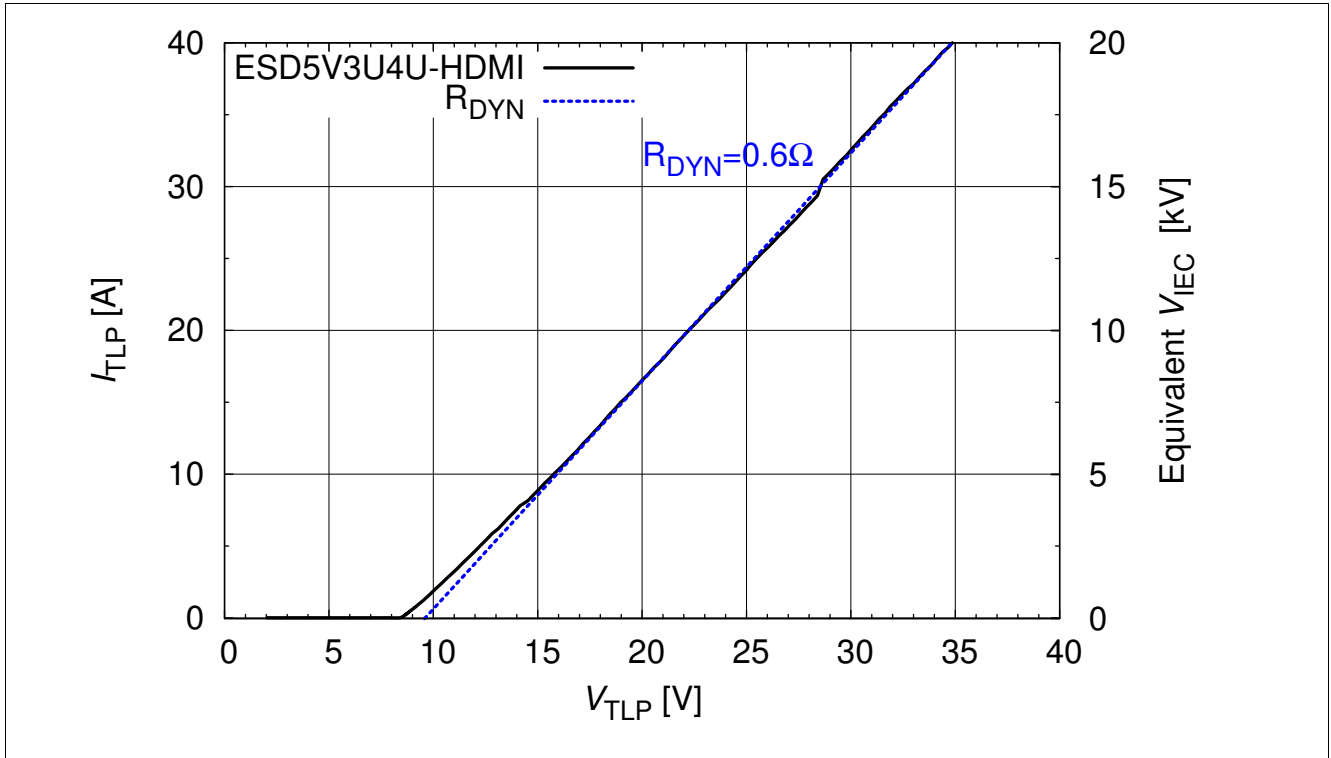

Figure 3-6 Forward clamping voltage: $I_{TLP} = f(V_{TLP})$, (GND to I/O) [1]

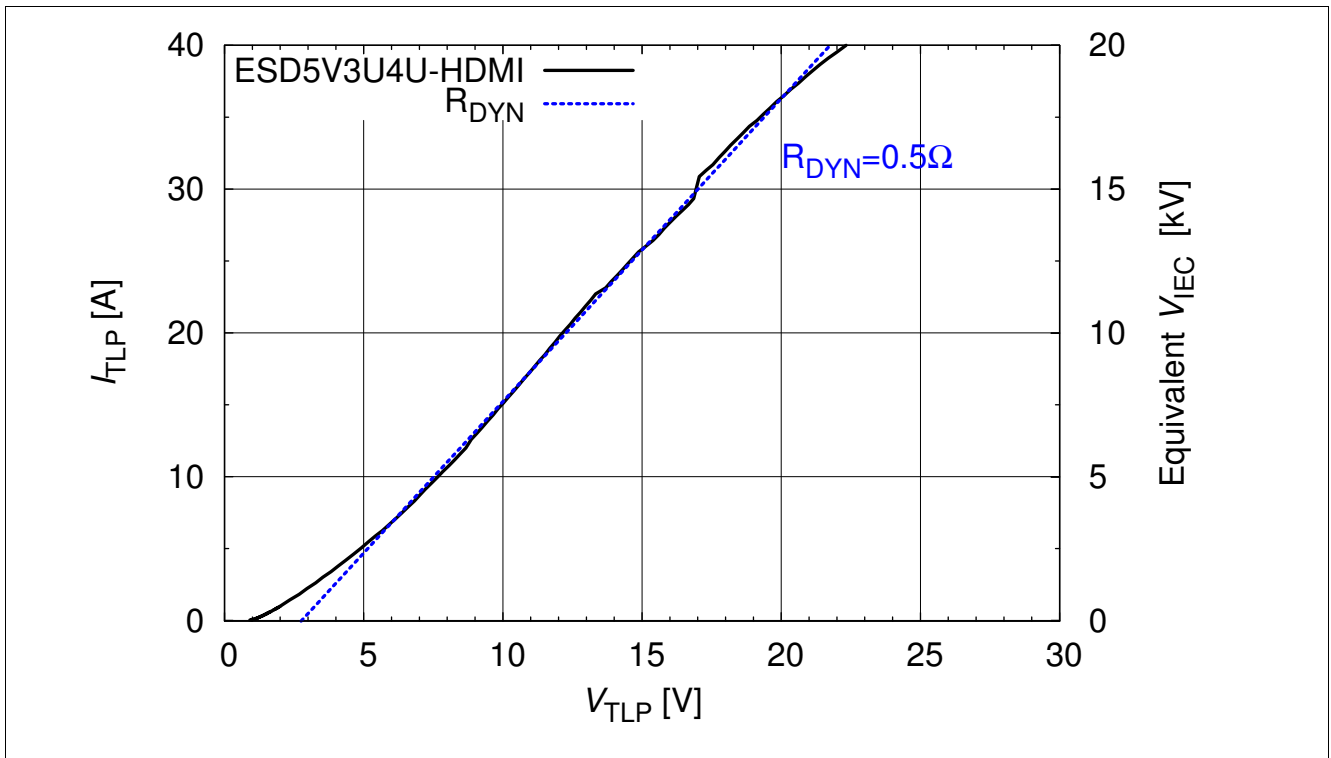

Figure 3-7 Reverse clamping voltage: $I_{TLP} = f(V_{TLP})$, (I/O to GND) [1]

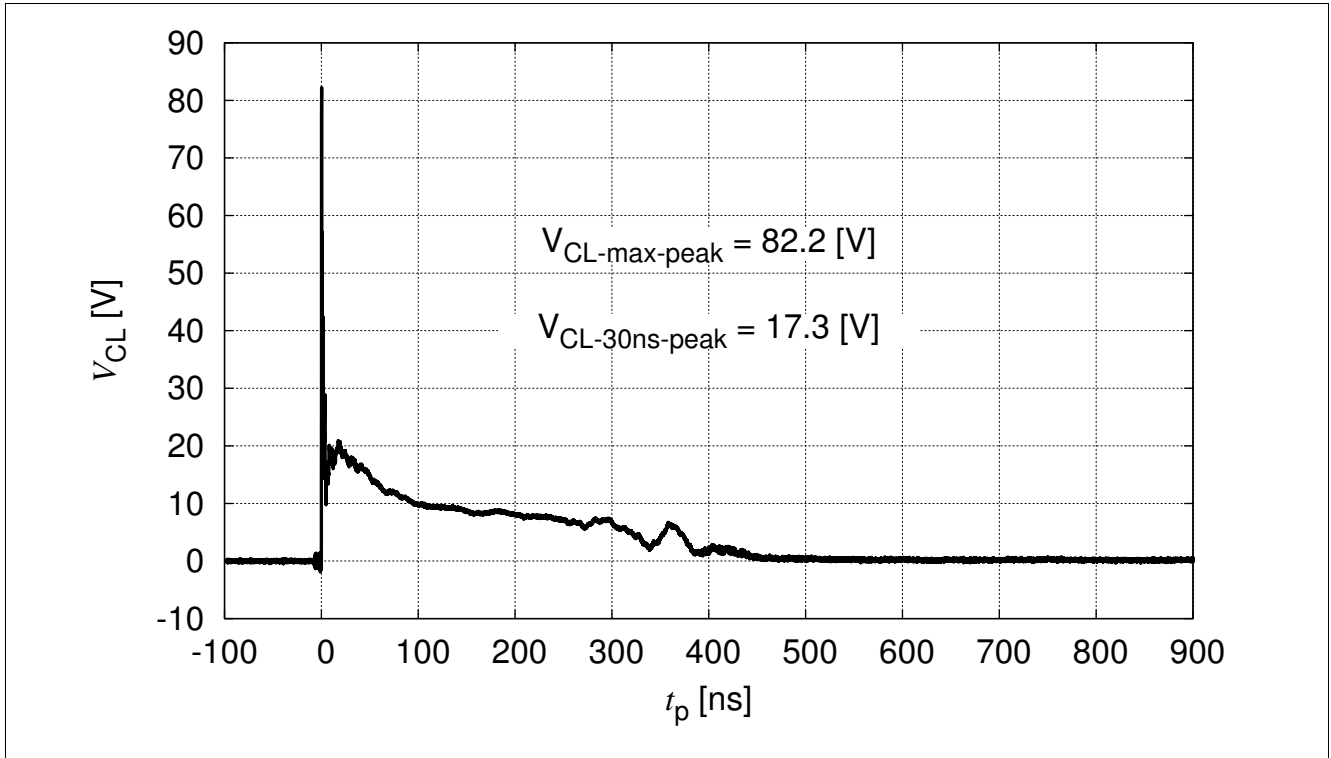

Figure 3-8 IEC61000-4-2 $V_{CL} = f(t)$, 8 kV positive pulse, (I/O to GND)

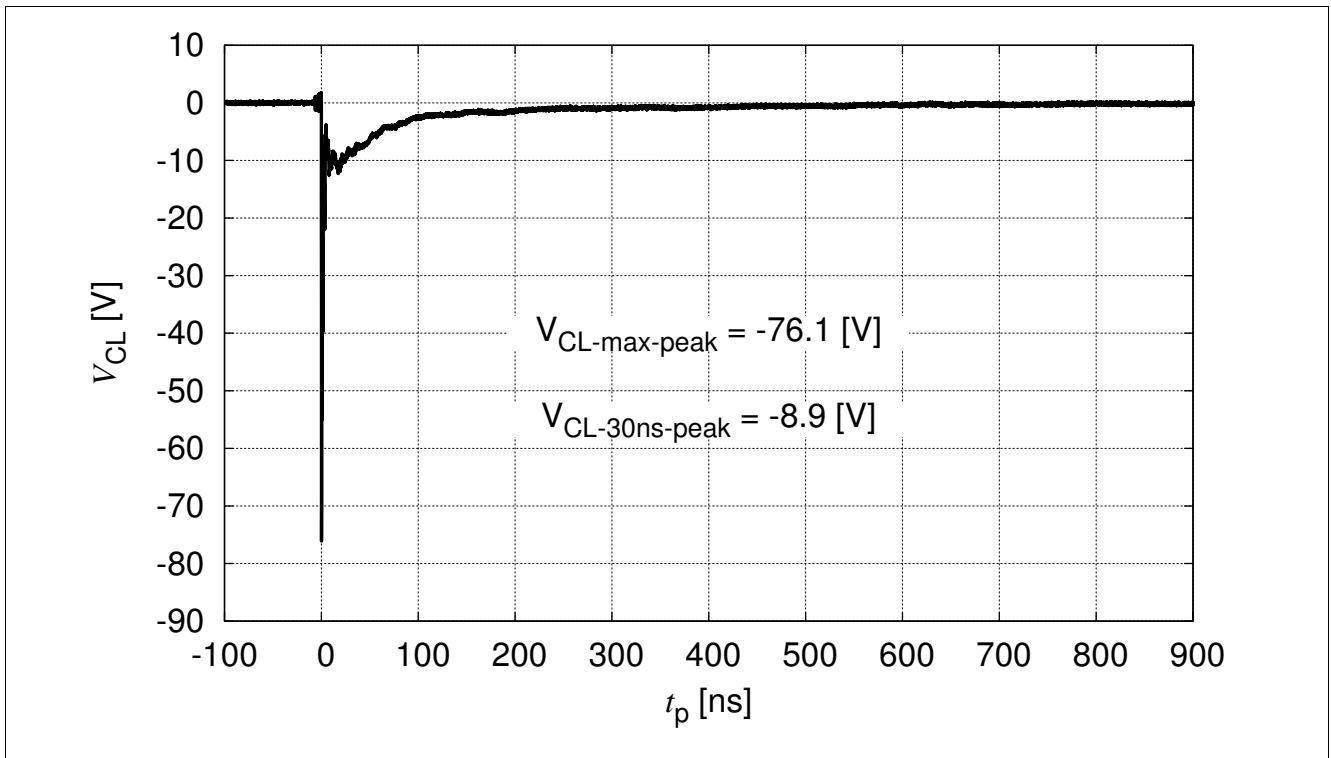

Figure 3-9 IEC61000-4-2 $V_{CL} = f(t)$, 8 kV negative pulse, (I/O to GND)

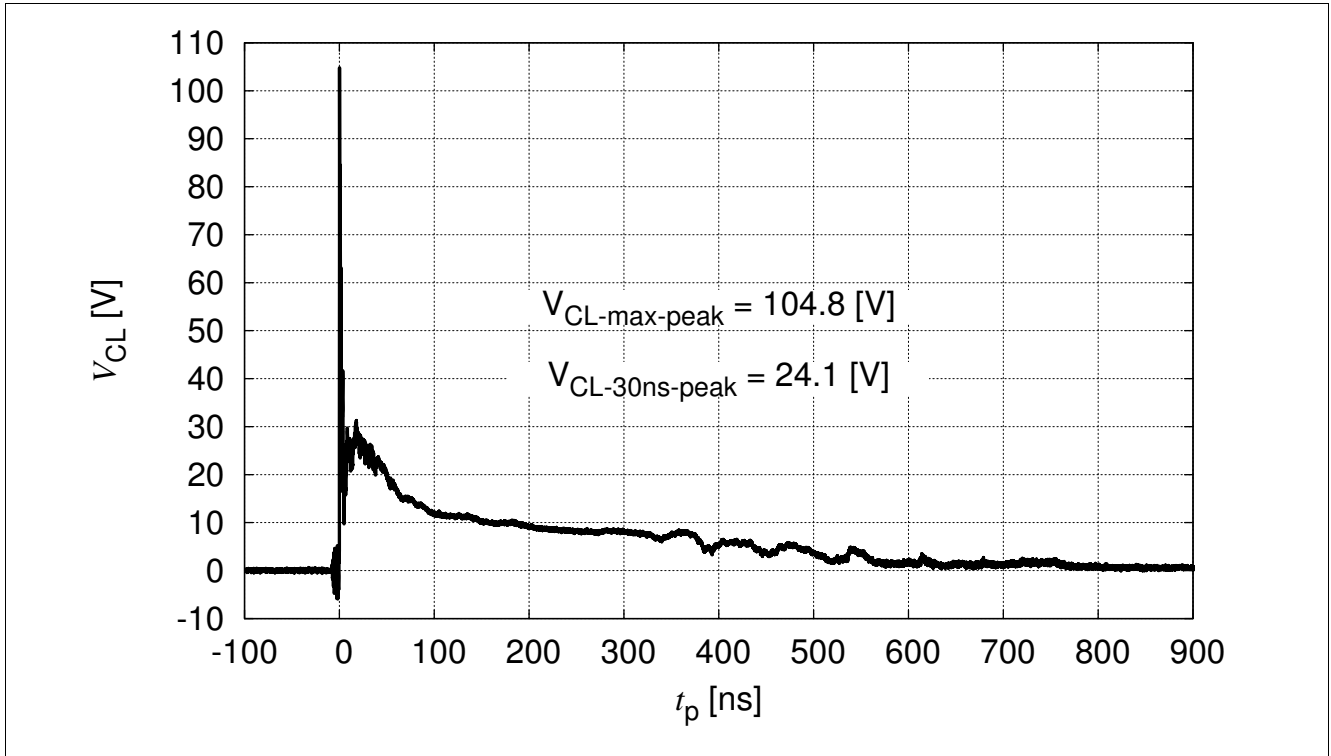

Figure 3-10 IEC61000-4-2 $V_{CL} = f(t)$, 15 kV positive pulse, (I/O to GND)

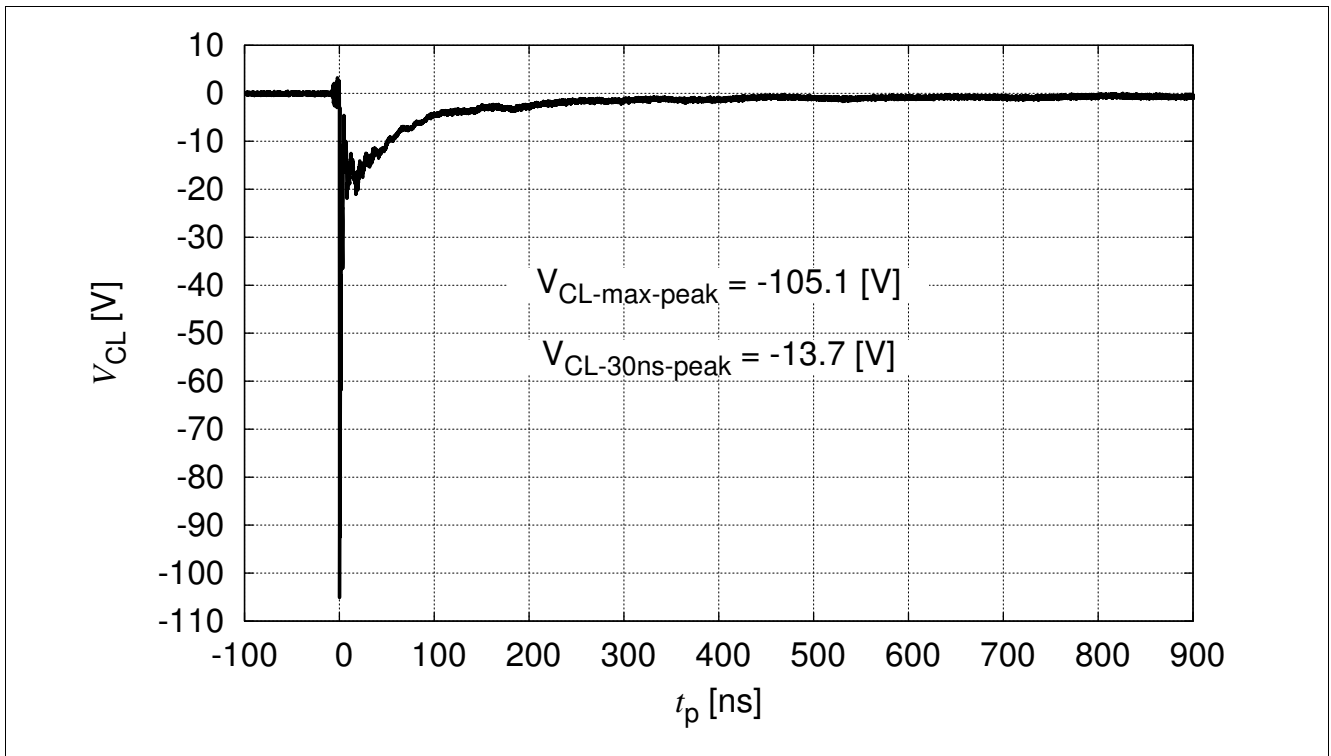

Figure 3-11 IEC61000-4-2 $V_{CL} = f(t)$, 15 kV negative pulse, (I/O to GND)

4 Application Information

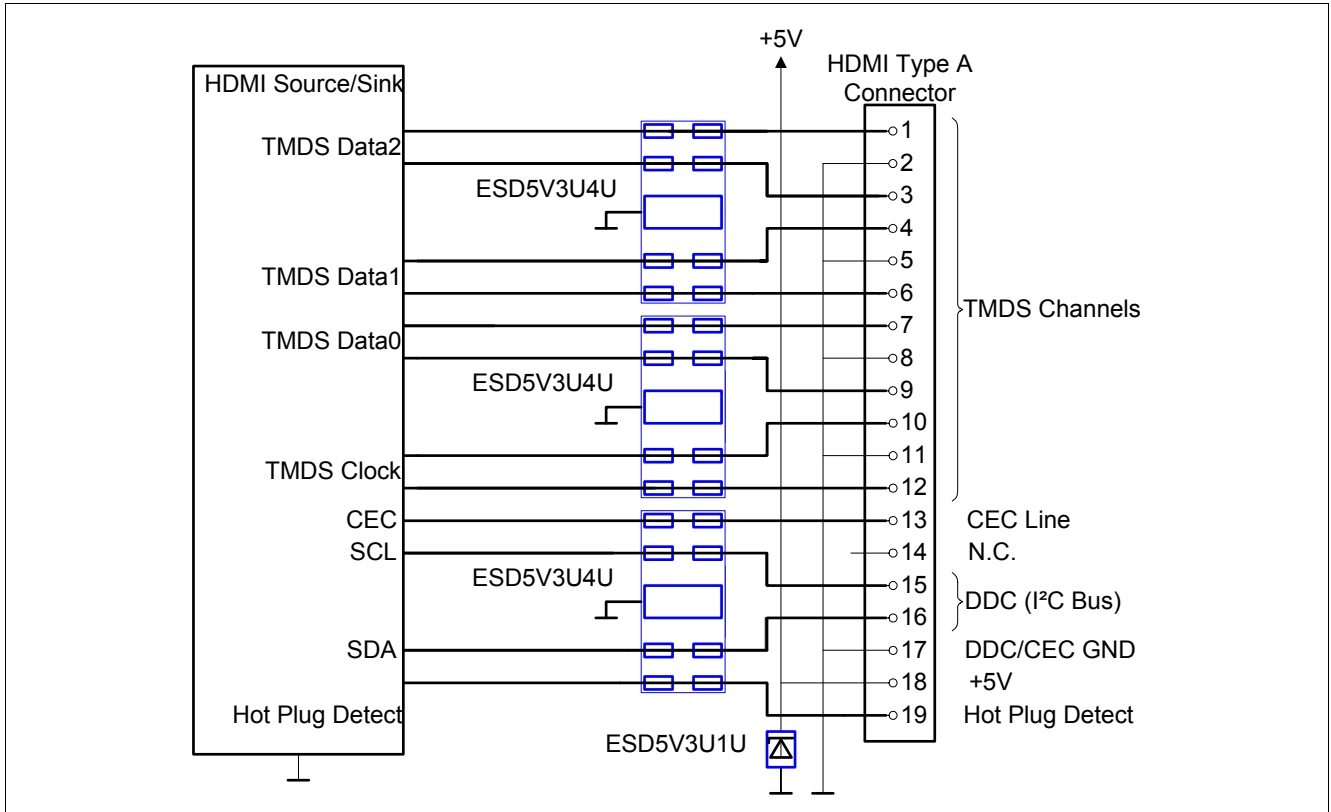

Figure 4-1 4 lines, uni-directional ESD5V3U4U-HDMI

For protection on the 5 V supply rail please refer to ESD5V3U1U- TVS diode data sheet.

5 Ordering Information Scheme (Examples)

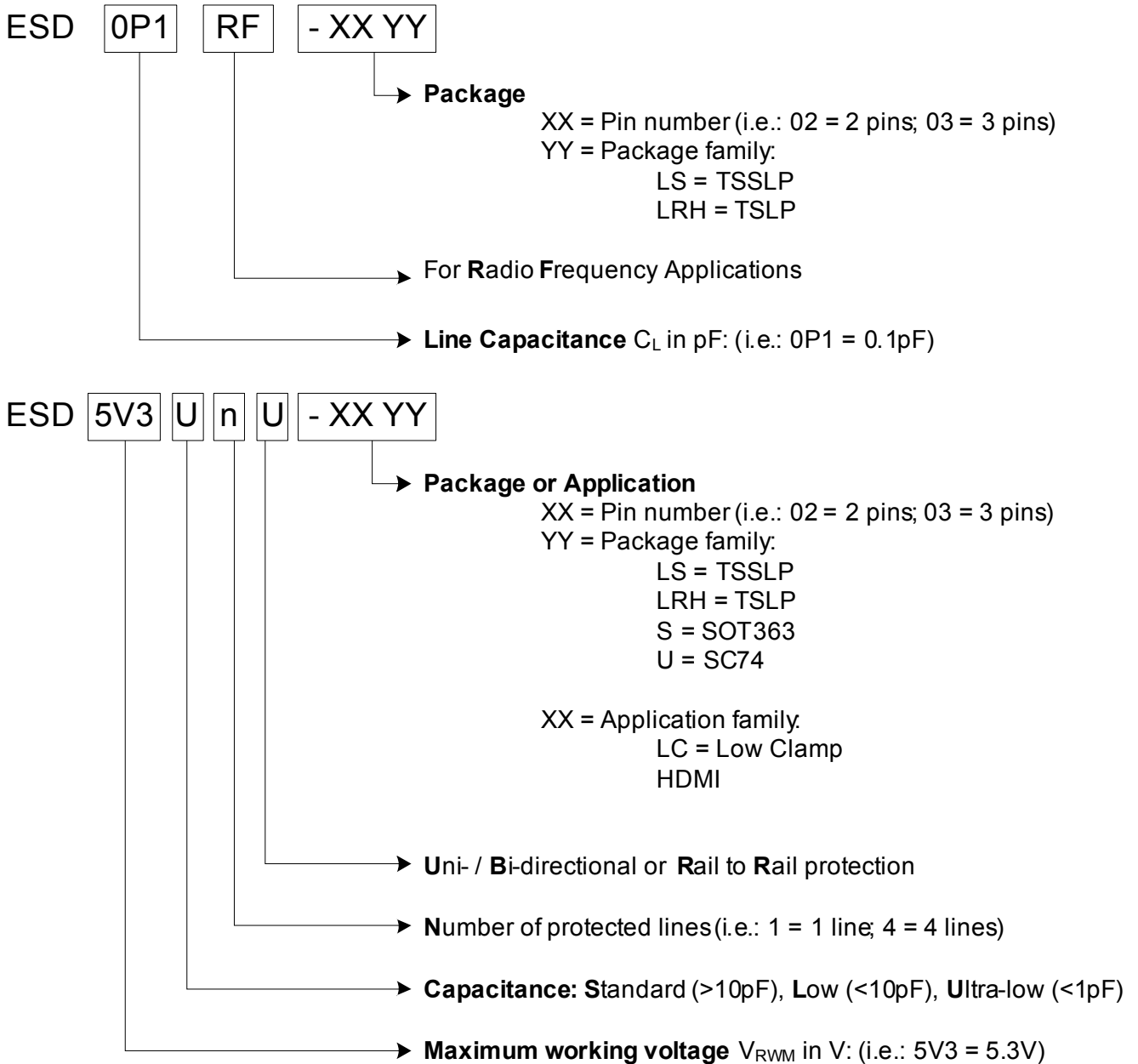

Figure 5-1 Ordering information scheme

6 Package Information

6.1 PG-TSLP-9-1

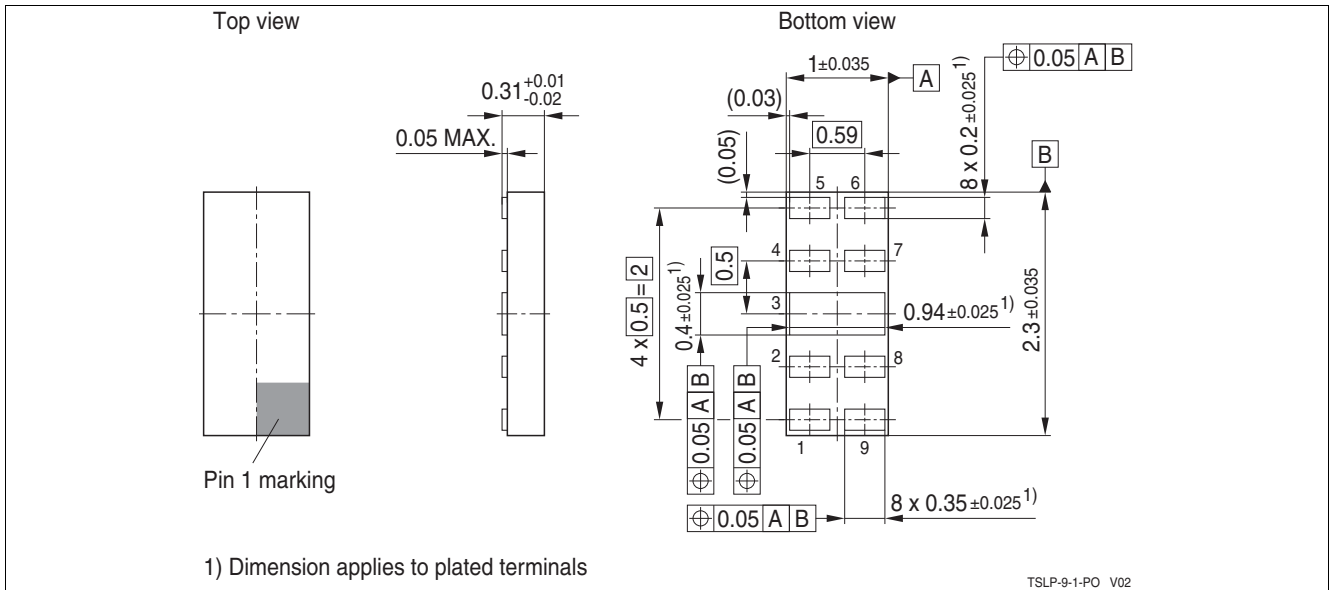

Figure 6-1 PG-TSLP-9-1: Package overview

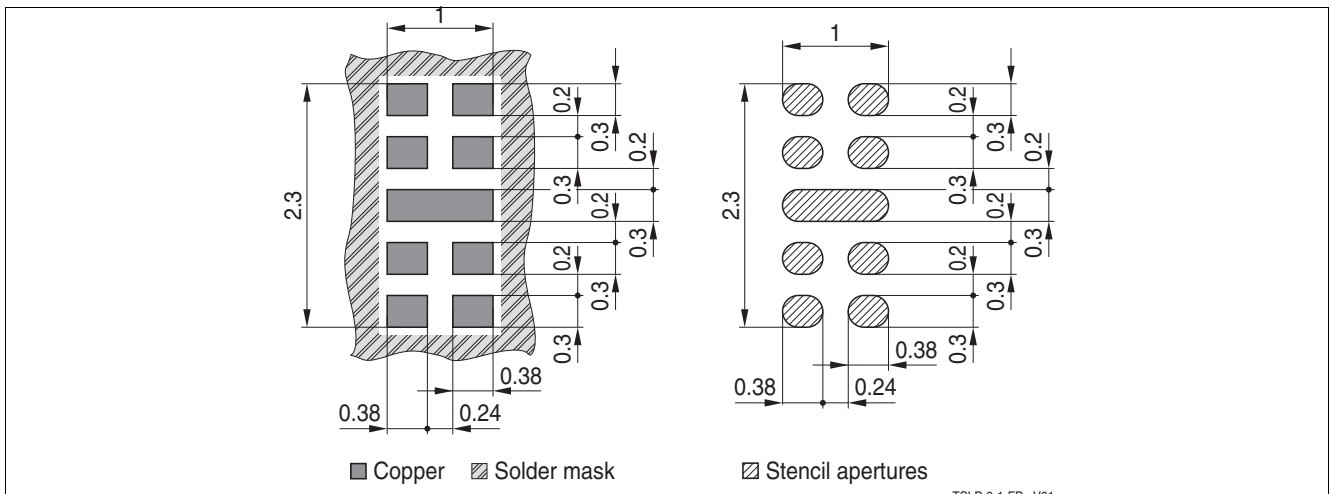

Figure 6-2 PG-TSLP-9-1: Footprint

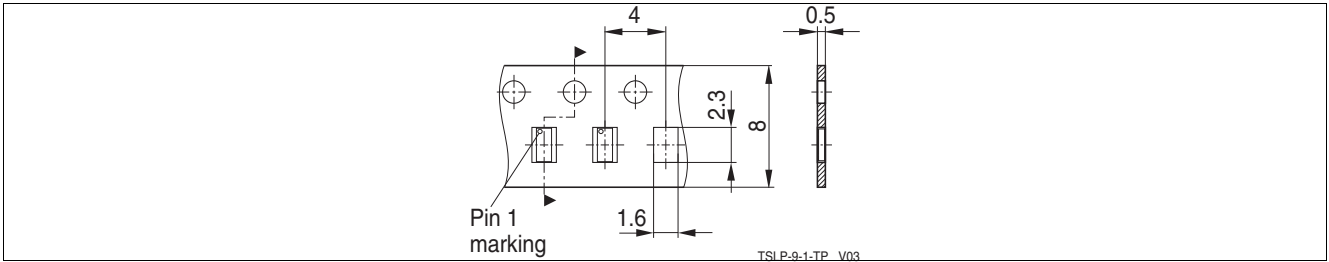

Figure 6-3 PG-TSLP-9-1: Packing

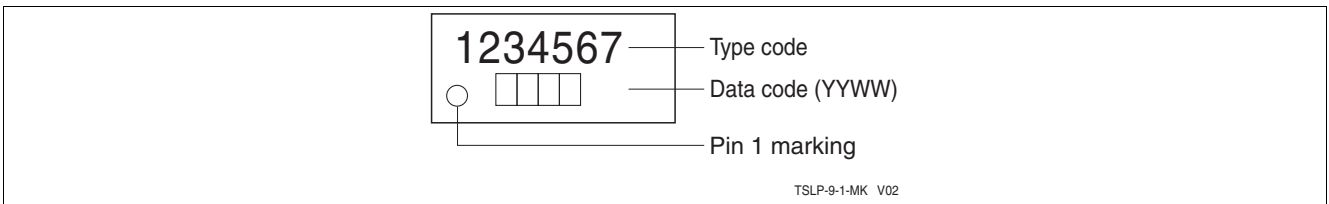

Figure 6-4 PG-TSLP-9-1: Marking (example)

References

- [1] Infineon AG - **Application Note AN210**: Effective ESD Protection Design at System Level Using VF-TLP Characterization Methodology

Terminology

C_L	Line capacitance
DVI	Digital Visual Interface
EFT	Electrical Fast Transient
ESD	Electrostatic Discharge
HDMI	High Definition Multimedia Interface
I_{PP}	Peak pulse current
I_R	Reverse current
MDDI	Mobile Display Digital Interface
MHL	Mobile Display Digital Interface
MIPI	Mobile Industrial Processor Interface
RoHS	Restriction of Hazardous Substances Directive
S-ATA	Serial Advanced Technology Attachment
T_{OP}	Operation temperature
t_p	Pulse duration
T_{stg}	Storage temperature
USB	Universal Serial Bus
V_{BR}	Breakdown voltage
V_{CL}	Reverse clamping voltage
V_{ESD}	Electrostatic discharge voltage
V_{FC}	Forward Clamping Voltage
V_R	Reverse voltage
V_{RWM}	Maximum Reverse Working Voltage

www.infineon.com

Published by Infineon Technologies AG