

16-Mbit, dual I/O, 4-Kbyte subsector erase, serial Flash memory with 75 MHz SPI bus interface

Features

- SPI bus compatible serial interface
- 75 MHz (maximum) clock frequency
- 2.3 V to 3.6 V single supply voltage
- Dual input/output instructions resulting in an equivalent clock frequency of 150 MHz:
 - Dual Output Fast Read instruction
 - Dual Input Fast Program instruction
- 16 Mbit Flash memory
 - Uniform 4-Kbyte subsectors
 - Uniform 64-Kbyte sectors
- Additional 64-byte user-lockable, one-time programmable (OTP) area
- Erase capability
 - Subsector (4-Kbyte) granularity
 - Sector (64-Kbyte) granularity
 - Bulk Erase (16 Mbit) in 15 s (typical)
- Write protections
 - Software write protection applicable to every 64-Kbyte sector (volatile lock bit)
 - Hardware write protection: protected area size defined by three non-volatile bits (BP0, BP1 and BP2)
- Deep Power-down mode: 5 μ A (typical)
- Electronic signature
 - JEDEC standard two-byte signature (7115h)
 - Unique ID code (UID) with 16 bytes read-only, available upon customer request
- More than 100 000 write cycles per sector
- More than 20 year data retention
- Packages
 - RoHS compliant
- Automotive certified parts available

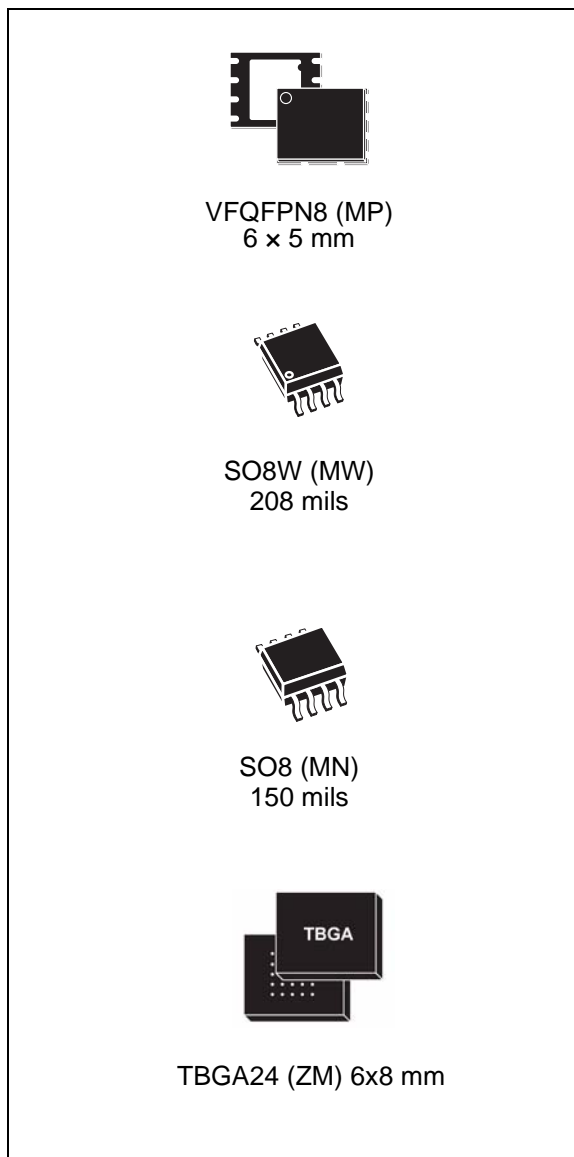

Contents

1	Description	6
2	Signal descriptions	9
2.1	Serial Data output (DQ1)	9
2.2	Serial Data input (DQ0)	9
2.3	Serial Clock (C)	9
2.4	Chip Select (\overline{S})	9
2.5	Hold (\overline{HOLD})	9
2.6	Write Protect/Enhanced Program supply voltage (\overline{W}/V_{PP})	9
2.7	V_{CC} supply voltage	10
2.8	V_{SS} ground	10
3	SPI modes	11
4	Operating features	13
4.1	Page programming	13
4.2	Dual Input Fast Program	13
4.3	Subsector Erase, Sector Erase and Bulk Erase	13
4.4	Polling during a Write, Program or Erase cycle	13
4.5	Active Power, Standby Power and Deep Power-down modes	14
4.6	Status Register	14
4.7	Protection modes	14
4.7.1	Protocol-related protections	15
4.7.2	Specific hardware and software protection	15
4.8	Hold condition	17
5	Memory organization	19
6	Instructions	22
6.1	Write Enable (WREN)	23
6.2	Write Disable (WRDI)	24
6.3	Read Identification (RDID)	24

6.4	Read Status Register (RDSR)	25
6.4.1	WIP bit	26
6.4.2	WEL bit	26
6.4.3	BP2, BP1, BP0 bits	26
6.4.4	TB bit	26
6.4.5	SRWD bit	27
6.5	Write Status Register (WRSR)	27
6.6	Read Data Bytes (READ)	29
6.7	Read Data Bytes at higher speed (FAST_READ)	30
6.8	Dual Output Fast Read (DOFR)	31
6.9	Read Lock Register (RDLR)	32
6.10	Read OTP (ROTP)	33
6.11	Page Program (PP)	34
6.12	Dual Input Fast Program (DIFP)	36
6.13	Program OTP instruction (POTP)	37
6.14	Write to Lock Register (WRLR)	39
6.15	Subsector Erase (SSE)	40
6.16	Sector Erase (SE)	41
6.17	Bulk Erase (BE)	41
6.18	Deep Power-down (DP)	42
6.19	Release from Deep Power-down (RDP)	43
7	Power-up and power-down	45
8	Initial delivery state	47
9	Maximum rating	48
10	DC and AC parameters	49
11	Package mechanical	56
12	Ordering information	62
13	Revision history	64

List of tables

Table 1.	Signal names	7
Table 2.	Software protection truth table (Sectors 0 to 63, 64 Kbyte granularity)	16
Table 3.	Protected area sizes	16
Table 4.	Memory organization	20
Table 5.	Instruction set	22
Table 6.	Read Identification (RDID) data-out sequence	25
Table 7.	Status Register format	26
Table 8.	Protection modes	28
Table 9.	Lock Register out	33
Table 10.	Lock Register in	40
Table 11.	Power-up timing and VWI threshold	46
Table 12.	Absolute maximum ratings	48
Table 13.	Data Retention	48
Table 14.	Operating conditions	49
Table 15.	AC measurement conditions	49
Table 16.	Capacitance	49
Table 17.	DC characteristics	50
Table 18.	AC characteristics	50
Table 19.	AC characteristics (50 MHz operation)	52
Table 20.	VFQFPN8 (MLP8) 8-lead very thin fine pitch dual flat package no lead, 6 × 5 mm, package mechanical data	56
Table 21.	SO8W 8-lead plastic small outline, 208 mils body width, package mechanical data	57
Table 22.	SO8N – 8 lead plastic small outline, 150 mils body width, package mechanical data	58
Table 23.	TBGA 6x8 mm 24-ball package dimensions	61
Table 24.	Ordering information scheme	62
Table 25.	Document revision history	64

List of figures

Figure 1.	Logic diagram	7
Figure 2.	VFQFPN and SO8 connections	7
Figure 3.	BGA 6x8 24 ball ballout	8
Figure 4.	Bus Master and memory devices on the SPI bus	11
Figure 5.	SPI modes supported	12
Figure 6.	Hold condition activation	18
Figure 7.	Block diagram	19
Figure 8.	Write Enable (WREN) instruction sequence	23
Figure 9.	Write Disable (WRDI) instruction sequence	24
Figure 10.	Read Identification (RDID) instruction sequence and data-out sequence	25
Figure 11.	Read Status Register (RDSR) instruction sequence and data-out sequence	27
Figure 12.	Write Status Register (WRSR) instruction sequence	28
Figure 13.	Read Data Bytes (READ) instruction sequence and data-out sequence	30
Figure 14.	Read Data Bytes at higher speed (FAST_READ) instruction sequence and data-out sequence	31
Figure 15.	Dual Output Fast Read instruction sequence	32
Figure 16.	Read Lock Register (RDLR) instruction sequence and data-out sequence	33
Figure 17.	Read OTP (ROTP) instruction and data-out sequence	34
Figure 18.	Page Program (PP) instruction sequence	35
Figure 19.	Dual Input Fast Program (DIFP) instruction sequence	37
Figure 20.	Program OTP (POTP) instruction sequence	38
Figure 21.	How to permanently lock the 64 OTP bytes	39
Figure 22.	Write to Lock Register (WRLR) instruction sequence	39
Figure 23.	Subsector Erase (SSE) instruction sequence	40
Figure 24.	Sector Erase (SE) instruction sequence	41
Figure 25.	Bulk Erase (BE) instruction sequence	42
Figure 26.	Deep Power-down (DP) instruction sequence	43
Figure 27.	Release from Deep Power-down (RDP) instruction sequence	44
Figure 28.	Power-up timing	46
Figure 29.	AC measurement I/O waveform	49
Figure 30.	Serial input timing	53
Figure 31.	Write Protect Setup and Hold timing during WRSR when SRWD=1	53
Figure 32.	Hold timing	54
Figure 33.	Output timing	54
Figure 34.	V _{PPH} timing	55
Figure 35.	VFQFPN8 (MLP8) 8-lead very thin fine pitch dual flat package no lead, 6 × 5 mm, package outline	56
Figure 36.	SO8W 8-lead plastic small outline, 208 mils body width, package outline	57
Figure 37.	SO8N – 8 lead plastic small outline, 150 mils body width, package outline	58
Figure 38.	TBGA, 6x8 mm, 24 ball package outline	60

1 Description

The M25PX16 is a 16 Mbit (2 Mb x 8) serial Flash memory, with advanced write protection mechanisms, accessed by a high speed SPI-compatible bus.

The M25PX16 supports two new, high-performance dual input/output instructions:

- Dual Output Fast Read (DOFR) instruction used to read data at up to 75 MHz⁽¹⁾ by using both pin DQ1 and pin DQ0 as outputs
- Dual Input Fast Program (DIFP) instruction used to program data at up to 75 MHz⁽¹⁾ by using both pin DQ1 and pin DQ0 as inputs

These new instructions double the transfer bandwidth for read and program operations.

The memory can be programmed 1 to 256 bytes at a time, using the Page Program instruction.

The memory is organized as 32 sectors that are further divided into 16 subsectors each (512 subsectors in total).

The memory can be erased a 4-Kbyte subsector at a time, a 64-Kbyte sector at a time, or as a whole. It can be Write Protected by software using a mix of volatile and non-volatile protection features, depending on the application needs. The protection granularity is of 64 Kbytes (sector granularity).

The M25PX16 has 64 one-time-programmable bytes (OTP bytes) that can be read and programmed using two dedicated instructions, Read OTP (ROTP) and Program OTP (POTP), respectively. These 64 bytes can be permanently locked by a particular Program OTP (POTP) sequence. Once they have been locked, they become read-only and this state cannot be reverted.

Further features are available as additional security options. More information on these security features is available, upon completion of an NDA (nondisclosure agreement), and are, therefore, not described in this datasheet. For more details of this option contact your nearest Numonyx Sales office.

1. 75 MHz operation is available only on the VCC range 2.7 V - 3.6 V

Figure 1. Logic diagram

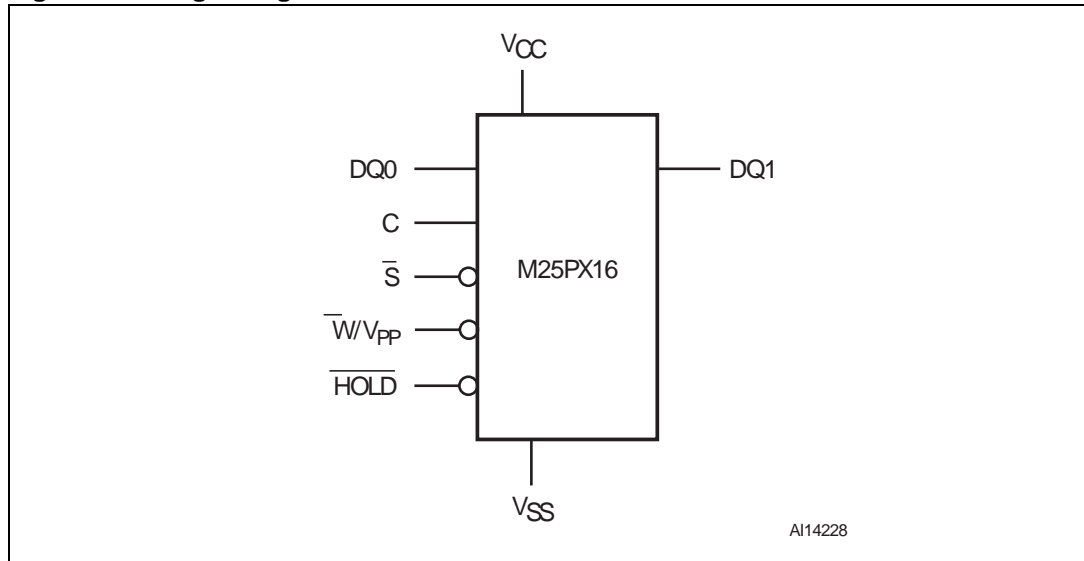
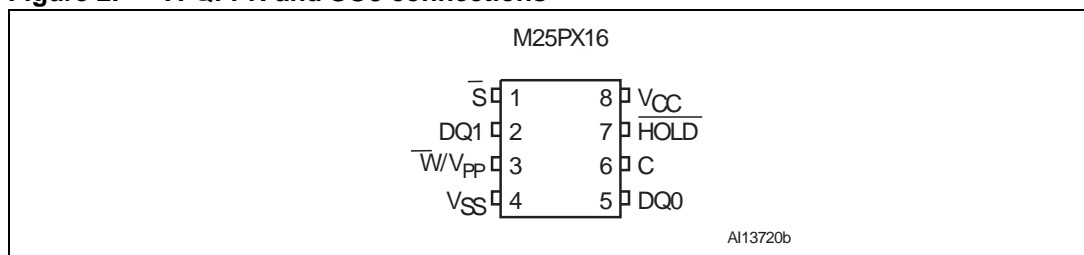

Table 1. Signal names

Signal name	Function	Direction
C	Serial Clock	Input
DQ0	Serial Data input	I/O ⁽¹⁾
DQ1	Serial Data output	I/O ⁽²⁾
\bar{S}	Chip Select	Input
\bar{W}/V_{PP}	Write Protect/Enhanced Program supply voltage	Input
HOLD	Hold	Input
V _{CC}	Supply voltage	
V _{SS}	Ground	

1. Serves as an output during Dual Output Fast Read (DOFR) instructions.
2. Serves as an input during Dual Input Fast Program (DIFP) instructions.

Figure 2. VFQFPN and SO8 connections



1. There is an exposed central pad on the underside of the VFQFPN package. This is pulled, internally, to V_{SS}, and must not be allowed to be connected to any other voltage or signal line on the PCB.
2. See [Package mechanical](#) section for package dimensions, and how to identify pin-1.

Figure 3. BGA 6x8 24 ball ballout

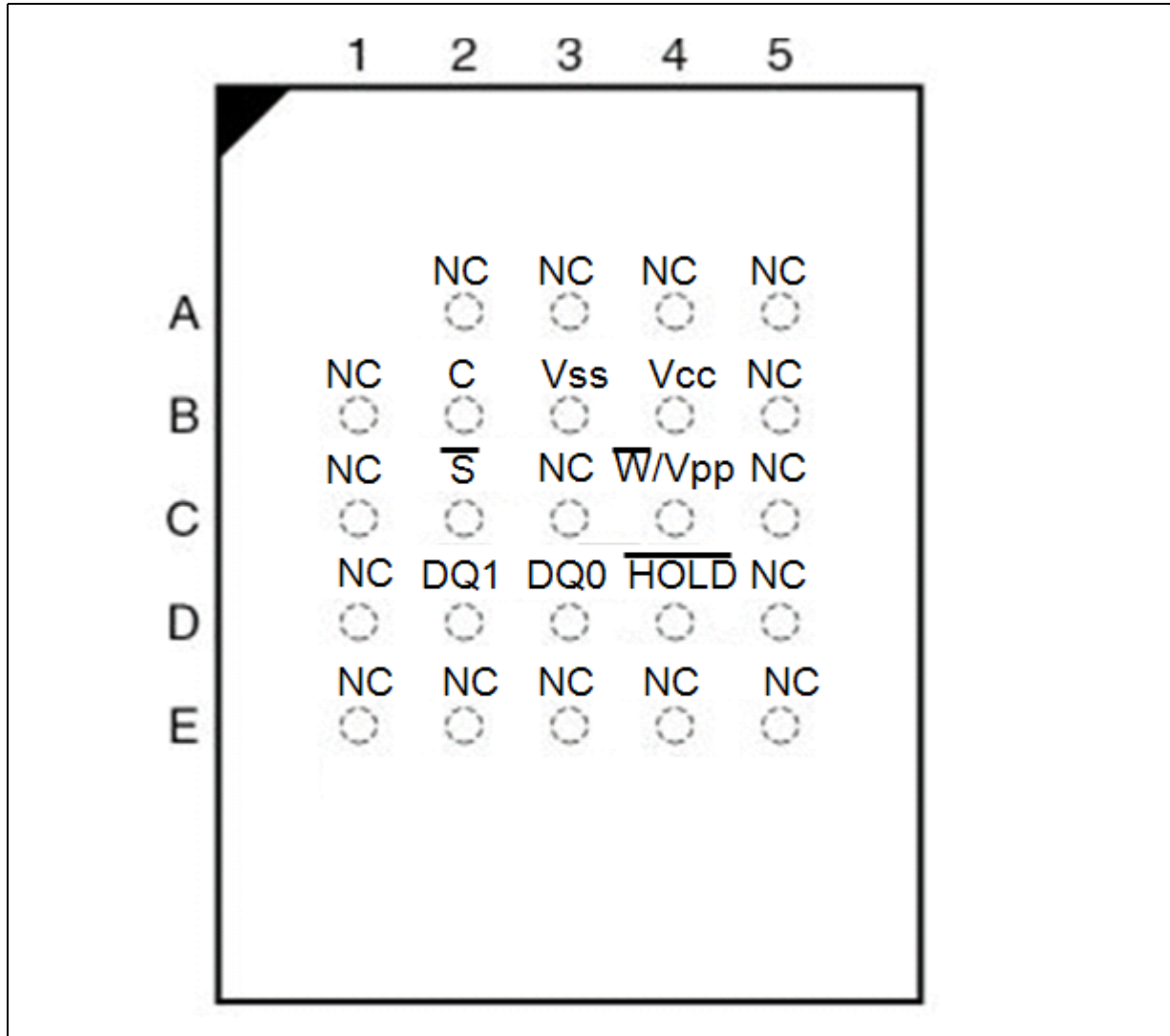

Note: 1 NC = No Connection

2 See [Section 11: Package mechanical](#).

2 Signal descriptions

2.1 Serial Data output (DQ1)

This output signal is used to transfer data serially out of the device. Data are shifted out on the falling edge of Serial Clock (C).

During the Dual Input Fast Program (DIFP) instruction, pin DQ1 is used as an input. It is latched on the rising edge of the Serial Clock (C).

2.2 Serial Data input (DQ0)

This input signal is used to transfer data serially into the device. It receives instructions, addresses, and the data to be programmed. Values are latched on the rising edge of Serial Clock (C).

During the Dual Output Fast Read (DOFR) instruction, pin DQ0 is used as an output. Data are shifted out on the falling edge of the Serial Clock (C).

2.3 Serial Clock (C)

This input signal provides the timing of the serial interface. Instructions, addresses, or data present at Serial Data input (DQ0) are latched on the rising edge of Serial Clock (C). Data on Serial Data output (DQ1) changes after the falling edge of Serial Clock (C).

2.4 Chip Select (\bar{S})

When this input signal is High, the device is deselected and Serial Data output (DQ1) is at high impedance. Unless an internal Program, Erase or Write Status Register cycle is in progress, the device will be in the Standby Power mode (this is not the Deep Power-down mode). Driving Chip Select (\bar{S}) Low enables the device, placing it in the Active Power mode.

After power-up, a falling edge on Chip Select (\bar{S}) is required prior to the start of any instruction.

2.5 Hold ($\overline{\text{HOLD}}$)

The Hold ($\overline{\text{HOLD}}$) signal is used to pause any serial communications with the device without deselecting the device.

During the Hold condition, the Serial Data output (DQ1) is high impedance, and Serial Data input (DQ0) and Serial Clock (C) are Don't care.

To start the Hold condition, the device must be selected, with Chip Select (\bar{S}) driven Low.

2.6 Write Protect/Enhanced Program supply voltage (\bar{W}/V_{PP})

\bar{W}/V_{PP} is both a control input and a power supply pin. The two functions are selected by the voltage range applied to the pin.

If the \overline{W}/V_{PP} input is kept in a low voltage range (0 V to V_{CC}) the pin is seen as a control input. This input signal is used to freeze the size of the area of memory that is protected against program or erase instructions (as specified by the values in the BP2, BP1 and BP0 bits of the Status Register. See [Table 9](#)).

If V_{PP} is in the range of V_{PPH} (as defined in [Table 15](#)) it acts as an additional power supply.⁽²⁾

2.7 V_{CC} supply voltage

V_{CC} is the supply voltage.

2.8 V_{SS} ground

V_{SS} is the reference for the V_{CC} supply voltage.

2. Avoid applying V_{PPH} to the \overline{W}/VPP pin during Bulk Erase.

3 SPI modes

These devices can be driven by a microcontroller with its SPI peripheral running in either of the two following modes:

- CPOL=0, CPHA=0
- CPOL=1, CPHA=1

For these two modes, input data is latched in on the rising edge of Serial Clock (C), and output data is available from the falling edge of Serial Clock (C).

The difference between the two modes, as shown in [Figure 5](#), is the clock polarity when the bus master is in Standby mode and not transferring data:

- C remains at 0 for (CPOL=0, CPHA=0)
- C remains at 1 for (CPOL=1, CPHA=1)

Figure 4. Bus Master and memory devices on the SPI bus

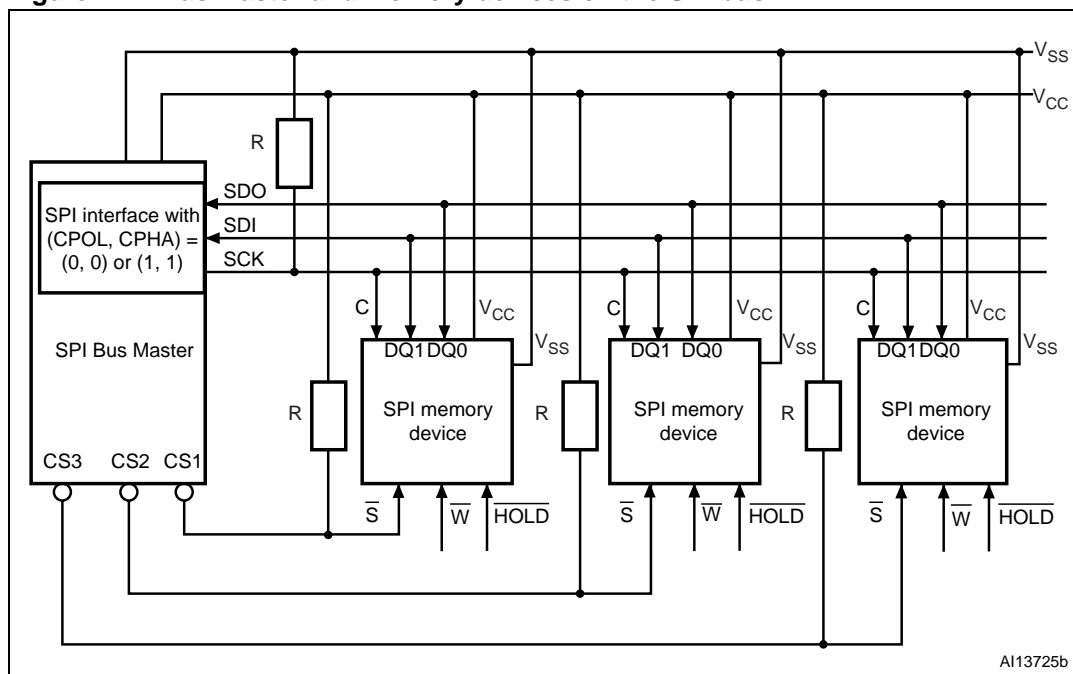

1. The Write Protect (\overline{W}) and Hold (\overline{HOLD}) signals should be driven, High or Low as appropriate.

[Figure 4](#) shows an example of three devices connected to an MCU, on an SPI bus. Only one device is selected at a time, so only one device drives the Serial Data output (DQ1) line at a time, the other devices are high impedance. Resistors R (represented in [Figure 4](#)) ensure that the M25PX16 is not selected if the Bus Master leaves the \overline{S} line in the high impedance state. As the Bus Master may enter a state where all inputs/outputs are in high impedance at the same time (for example, when the Bus Master is reset), the clock line (C) must be connected to an external pull-down resistor so that, when all inputs/outputs become high impedance, the \overline{S} line is pulled High while the C line is pulled Low (thus ensuring that \overline{S} and C do not become High at the same time, and so, that the t_{SHCH} requirement is met). The typical value of R is 100 k Ω , assuming that the time constant $R \cdot C_p$ (C_p = parasitic capacitance of the bus line) is shorter than the time during which the Bus Master leaves the SPI bus in high impedance.

Example: $C_p = 50 \text{ pF}$, that is $R \cdot C_p = 5 \text{ }\mu\text{s} \iff$ the application must ensure that the Bus Master never leaves the SPI bus in the high impedance state for a time period shorter than $5 \text{ }\mu\text{s}$.

Figure 5. SPI modes supported

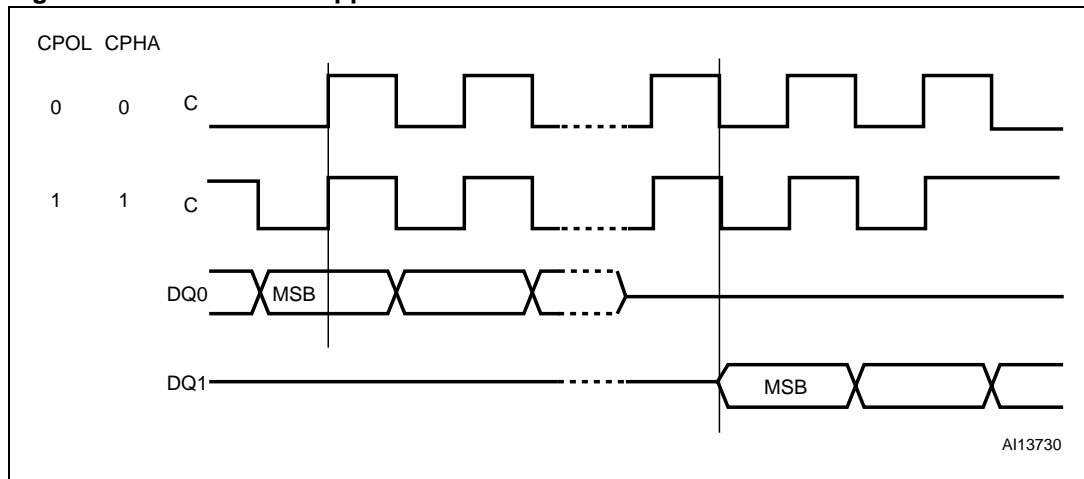

4 Operating features

4.1 Page programming

To program one data byte, two instructions are required: Write Enable (WREN), which is one byte, and a Page Program (PP) sequence, which consists of four bytes plus data. This is followed by the internal Program cycle (of duration t_{PP}).

To spread this overhead, the Page Program (PP) instruction allows up to 256 bytes to be programmed at a time (changing bits from 1 to 0), provided that they lie in consecutive addresses on the same page of memory.

For optimized timings, it is recommended to use the Page Program (PP) instruction to program all consecutive targeted bytes in a single sequence versus using several Page Program (PP) sequences with each containing only a few bytes (see [Page Program \(PP\)](#) and [Table 18: AC characteristics](#)).

4.2 Dual Input Fast Program

The Dual Input Fast Program (DIFP) instruction makes it possible to program up to 256 bytes using two input pins at the same time (by changing bits from 1 to 0).

For optimized timings, it is recommended to use the Dual Input Fast Program (DIFP) instruction to program all consecutive targeted bytes in a single sequence rather to using several Dual Input Fast Program (DIFP) sequences each containing only a few bytes (see [Section 6.12: Dual Input Fast Program \(DIFP\)](#)).

4.3 Subsector Erase, Sector Erase and Bulk Erase

The Page Program (PP) instruction allows bits to be reset from 1 to 0. Before this can be applied, the bytes of memory need to have been erased to all 1s (FFh). This can be achieved either a subsector at a time, using the Subsector Erase (SSE) instruction, a sector at a time, using the Sector Erase (SE) instruction, or throughout the entire memory, using the Bulk Erase (BE) instruction. This starts an internal Erase cycle (of duration t_{SSE} , t_{SE} or t_{BE}).

The Erase instruction must be preceded by a Write Enable (WREN) instruction.

4.4 Polling during a Write, Program or Erase cycle

A further improvement in the time to Write Status Register (WRSR), Program OTP (POTP), Program (PP), Dual Input Fast Program (DIFP) or Erase (SSE, SE or BE) can be achieved by not waiting for the worst case delay (t_W , t_{PP} , t_{SSE} , t_{SE} , or t_{BE}). The Write In Progress (WIP) bit is provided in the Status Register so that the application program can monitor its value, polling it to establish when the previous Write cycle, Program cycle or Erase cycle is complete.

4.5 Active Power, Standby Power and Deep Power-down modes

When Chip Select (\bar{S}) is Low, the device is selected, and in the Active Power mode.

When Chip Select (\bar{S}) is High, the device is deselected, but could remain in the Active Power mode until all internal cycles have completed (Program, Erase, Write Status Register). The device then goes in to the Standby Power mode. The device consumption drops to I_{CC1} .

The Deep Power-down mode is entered when the specific instruction (the Deep Power-down (DP) instruction) is executed. The device consumption drops further to I_{CC2} . The device remains in this mode until another specific instruction (the Release from Deep Power-down (RDP) instruction) is executed.

While in the Deep Power-down mode, the device ignores all Write, Program and Erase instructions (see [Deep Power-down \(DP\)](#)), this can be used as an extra software protection mechanism, when the device is not in active use, to protect the device from inadvertent Write, Program or Erase instructions.

4.6 Status Register

The Status Register contains a number of status and control bits that can be read or set (as appropriate) by specific instructions. See [Section 6.4: Read Status Register \(RDSR\)](#) for a detailed description of the Status Register bits.

4.7 Protection modes

There are protocol-related and specific hardware and software protection modes. They are described below.

4.7.1 Protocol-related protections

The environments where non-volatile memory devices are used can be very noisy. No SPI device can operate correctly in the presence of excessive noise. To help combat this, the M25PX16 features the following data protection mechanisms:

- Power On Reset and an internal timer (t_{PUW}) can provide protection against inadvertent changes while the power supply is outside the operating specification
- Program, Erase and Write Status Register instructions are checked that they consist of a number of clock pulses that is a multiple of eight, before they are accepted for execution
- All instructions that modify data must be preceded by a Write Enable (WREN) instruction to set the Write Enable Latch (WEL) bit. This bit is returned to its reset state by the following events:
 - Power-up
 - Write Disable (WRDI) instruction completion
 - Write Status Register (WRSR) instruction completion
 - Write to Lock Register (WRLR) instruction completion
 - Program OTP (POTP) instruction completion
 - Page Program (PP) instruction completion
 - Dual Input Fast Program (DIFP) instruction completion
 - Subsector Erase (SSE) instruction completion
 - Sector Erase (SE) instruction completion
 - Bulk Erase (BE) instruction completion
- In addition to the low power consumption feature, the Deep Power-down mode offers extra software protection, as all Write, Program and Erase instructions are ignored.

4.7.2 Specific hardware and software protection

There are two software protected modes, SPM1 and SPM2, that can be combined to protect the memory array as required. The SPM2 can be locked by hardware with the help of the \overline{W} input pin.

SPM1 and SPM2

- The first software protected mode (SPM1) is managed by specific Lock Registers assigned to each 64 Kbyte sector.

The Lock Registers can be read and written using the Read Lock Register (RDLR) and Write to Lock Register (WRLR) instructions.

In each Lock Register two bits control the protection of each sector: the Write Lock bit and the Lock Down bit.

 - Write Lock bit:

The Write Lock bit determines whether the contents of the sector can be modified (using the Write, Program or Erase instructions). When the Write Lock bit is set to '1', the sector is write protected – any operations that attempt to change the data in the sector will fail. When the Write Lock bit is reset to '0', the sector is not write protected by the Lock Register, and may be modified.
 - Lock Down bit:

The Lock Down bit provides a mechanism for protecting software data from simple hacking and malicious attack. When the Lock Down bit is set, '1', further

modification to the Write Lock and Lock Down bits cannot be performed. A power-up, is required before changes to these bits can be made. When the Lock Down bit is reset, '0', the Write Lock and Lock Down bits can be changed.

The definition of the Lock Register bits is given in [Table 9: Lock Register out](#).

Table 2. Software protection truth table (Sectors 0 to 63, 64 Kbyte granularity)

Sector Lock Register		Protection status
Lock Down bit	Write Lock bit	
0	0	Sector unprotected from Program/Erase/Write operations, protection status reversible
0	1	Sector protected from Program/Erase/Write operations, protection status reversible
1	0	Sector unprotected from Program/Erase/Write operations, Sector protection status cannot be changed except by a power-up.
1	1	Sector protected from Program/Erase/Write operations, Sector protection status cannot be changed except by a Power-up.

- the second software protected mode (SPM2) uses the Block Protect bits (see [Section 6.4.3: BP2, BP1, BP0 bits](#)) and the Top/Bottom bit (see [Section 6.4.4: TB bit](#)) to allow part of the memory to be configured as read-only.

Table 3. Protected area sizes

Status Register contents				Memory content	
TB bit	BP bit 2	BP bit 1	BP bit 0	Protected area	Unprotected area
0	0	0	0	none	All sectors ⁽¹⁾ (32 sectors: 0 to 31)
0	0	0	1	Upper 32nd (Sector 31)	Lower 31/32nds (31 sectors: 0 to 30)
0	0	1	0	Upper 16th (2 sectors: 30 and 31)	Lower 15/16ths (30 sectors: 0 to 29)
0	0	1	1	Upper 8th (4 sectors: 28 to 31)	Lower 7/8ths (28 sectors: 0 to 27)
0	1	0	0	Upper 4th (8 sectors: 24 to 31)	Lower 3/4ths (24 sectors: 0 to 23)
0	1	0	1	Upper half (16 sectors: 16 to 31)	Lower half (16 sectors: 0 to 15)
0	1	1	0	All sectors (32 sectors: 0 to 31)	none
0	1	1	1	All sectors (32 sectors: 0 to 31)	none
1	0	0	0	none	All sectors ⁽¹⁾ (32 sectors: 0 to 31)
1	0	0	1	Lower 32nd (sector 0)	Upper 31/32nds (31 sectors: 1 to 31)
1	0	1	0	Lower 16th (2 sectors: 0 and 1)	Upper 15/16ths (30 sectors: 2 to 31)
1	0	1	1	Lower 8th (4 sectors: 0 to 3)	Upper 7/8ths (28 sectors: 4 to 31)
1	1	0	0	Lower 4th (8 sectors: 0 to 7)	Upper 3/4ths (24 sectors: 8 to 31)
1	1	0	1	Lower half (16 sectors: 0 to 15)	Upper half (16 sectors: 16 to 31)

Table 3. Protected area sizes

Status Register contents				Memory content	
TB bit	BP bit 2	BP bit 1	BP bit 0	Protected area	Unprotected area
1	1	1	0	All sectors (32 sectors: 0 to 31)	none
1	1	1	1	All sectors (32 sectors: 0 to 31)	none

1. The device is ready to accept a Bulk Erase instruction if, and only if, all Block Protect (BP2, BP1, BP0) are 0.

As a second level of protection, the Write Protect signal (applied on the \overline{W}/V_{PP} pin) can freeze the Status Register in a read-only mode. In this mode, the Block Protect bits (BP2, BP1, BP0) and the Status Register Write Disable bit (SRWD) are protected. For more details, see [Section 6.5: Write Status Register \(WRSR\)](#).

4.8 Hold condition

The Hold (\overline{HOLD}) signal is used to pause any serial communications with the device without resetting the clocking sequence. However, taking this signal Low does not terminate any Write Status Register, Program or Erase cycle that is currently in progress.

To enter the Hold condition, the device must be selected, with Chip Select (\overline{S}) Low.

The Hold condition starts on the falling edge of the Hold (\overline{HOLD}) signal, provided that this coincides with Serial Clock (C) being Low (as shown in [Figure 6](#)).

The Hold condition ends on the rising edge of the Hold (\overline{HOLD}) signal, provided that this coincides with Serial Clock (C) being Low.

If the falling edge does not coincide with Serial Clock (C) being Low, the Hold condition starts after Serial Clock (C) next goes Low. Similarly, if the rising edge does not coincide with Serial Clock (C) being Low, the Hold condition ends after Serial Clock (C) next goes Low. (This is shown in [Figure 6](#)).

During the Hold condition, the Serial Data output (DQ1) is high impedance, and Serial Data input (DQ0) and Serial Clock (C) are Don't care.

Normally, the device is kept selected, with Chip Select (\overline{S}) driven Low, for the whole duration of the Hold condition. This is to ensure that the state of the internal logic remains unchanged from the moment of entering the Hold condition.

If Chip Select (\overline{S}) goes High while the device is in the Hold condition, this has the effect of resetting the internal logic of the device. To restart communication with the device, it is necessary to drive Hold (\overline{HOLD}) High, and then to drive Chip Select (\overline{S}) Low. This prevents the device from going back to the Hold condition.

Figure 6. Hold condition activation

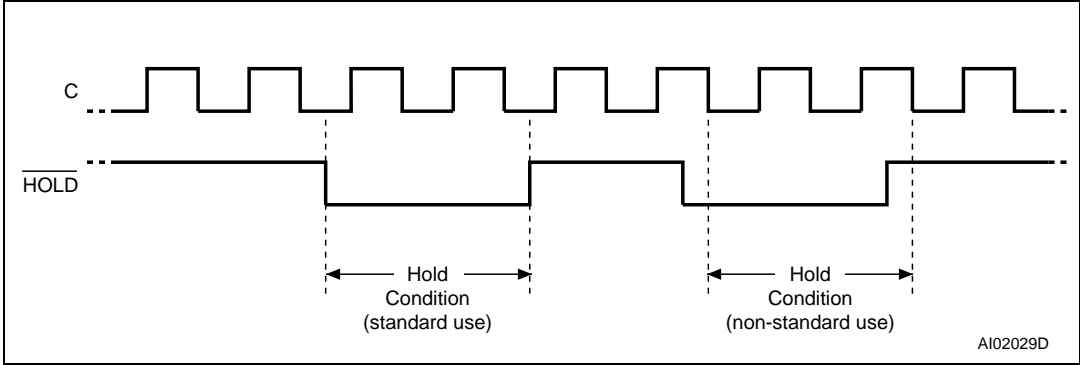

5 Memory organization

The memory is organized as:

- 2 097 152 bytes (8 bits each)
- 512 subsectors (4 Kbytes each)
- 32 sectors (64 Kbytes each)
- 8192 pages (256 bytes each)
- 64 OTP bytes located outside the main memory array

Each page can be individually programmed (bits are programmed from 1 to 0). The device is Subsector, Sector or Bulk Erasable (bits are erased from 0 to 1) but not Page Erasable.

Figure 7. Block diagram

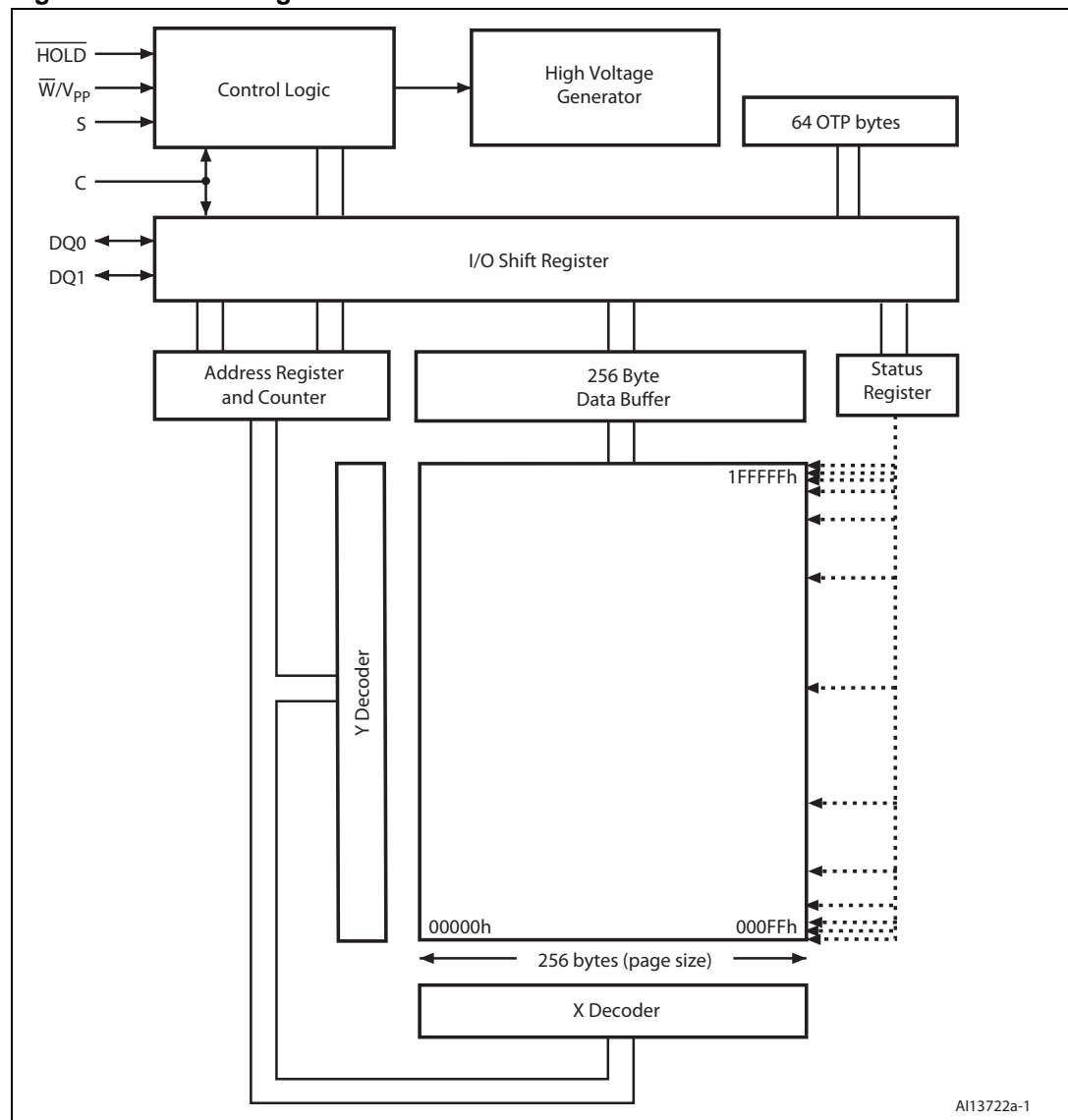

Table 4. Memory organization

Sector	Subsector	Address range		Sector	Subsector	Address range	
31	511	1FF000h	1FFFFFFh	20	335	14F000h	14FFFFh
	⋮	⋮	⋮		⋮	⋮	⋮
30	496	1F0000h	1F0FFFh	19	320	140000h	140FFFh
	⋮	⋮	⋮		⋮	⋮	⋮
29	480	1E0000h	1E0FFFh	18	319	13F000h	13FFFFh
	⋮	⋮	⋮		⋮	⋮	⋮
28	479	1DF000h	1DFFFFh	17	304	130000h	130FFFh
	⋮	⋮	⋮		⋮	⋮	⋮
27	464	1D0000h	1D0FFFh	16	303	12F000h	12FFFFh
	⋮	⋮	⋮		⋮	⋮	⋮
26	463	1CF000h	1CFFFFh	15	288	120000h	120FFFh
	⋮	⋮	⋮		⋮	⋮	⋮
25	448	1C0000h	1C0FFFh	14	287	11F000h	11FFFFh
	⋮	⋮	⋮		⋮	⋮	⋮
24	447	1BF000h	1BFFFFh	13	272	110000h	110FFFh
	⋮	⋮	⋮		⋮	⋮	⋮
23	432	1B0000h	1B0FFFh	12	271	10F000h	10FFFFh
	⋮	⋮	⋮		⋮	⋮	⋮
22	431	1AF000h	1AFFFFh	11	256	100000h	100FFFh
	⋮	⋮	⋮		⋮	⋮	⋮
21	416	1A0000h	1A0FFFh	10	255	FF000h	FFFFFh
	⋮	⋮	⋮		⋮	⋮	⋮
20	415	19F000h	19FFFFh	9	240	F0000h	F0FFFh
	⋮	⋮	⋮		⋮	⋮	⋮
19	400	190000h	190FFFh	8	239	EF000h	EFFFFh
	⋮	⋮	⋮		⋮	⋮	⋮
18	399	18F000h	18FFFFh	7	224	E0000h	E0FFFh
	⋮	⋮	⋮		⋮	⋮	⋮
17	384	180000h	180FFFh	6	223	DF000h	DFFFFh
	⋮	⋮	⋮		⋮	⋮	⋮
16	383	17F000h	17FFFFh	5	208	D0000h	D0FFFh
	⋮	⋮	⋮		⋮	⋮	⋮
15	368	170000h	170FFFh	4	207	CF000h	CFFFFh
	⋮	⋮	⋮		⋮	⋮	⋮
14	367	16F000h	16FFFFh	3	192	C0000h	C0FFFh
	⋮	⋮	⋮		⋮	⋮	⋮
13	352	160000h	160FFFh	2	191	BF000h	BFFFFh
	⋮	⋮	⋮		⋮	⋮	⋮
12	351	15F000h	15FFFFh	1	176	B0000h	B0FFFh
	⋮	⋮	⋮		⋮	⋮	⋮
11	336	150000h	150FFFh	0	175	AF000h	AFFFFh
	⋮	⋮	⋮		⋮	⋮	⋮
10	⋮	⋮	⋮	-1	160	A0000h	A0FFFh
	⋮	⋮	⋮		⋮	⋮	⋮

Table 4. Memory organization (continued)

Sector	Subsector	Address range		Sector	Subsector	Address range		
9	159	9F000h	9FFFFh	3	63	3F000h	3FFFFh	
	⋮	⋮	⋮		⋮	⋮	⋮	⋮
	144	90000h	90FFFh		48	30000h	30FFFh	
8	143	8F000h	8FFFFh	2	47	2F000h	2FFFFh	
	⋮	⋮	⋮		⋮	⋮	⋮	⋮
	128	80000h	80FFFh		32	20000h	20FFFh	
7	127	7F000h	7FFFFh	1	31	1F000h	1FFFFh	
	⋮	⋮	⋮		⋮	⋮	⋮	⋮
	112	70000h	70FFFh		16	10000h	10FFFh	
6	111	6F000h	6FFFFh	0	15	0F000h	0FFFFh	
	⋮	⋮	⋮		⋮	⋮	⋮	⋮
	96	60000h	60FFFh		4	04000h	04FFFh	
5	95	5F000h	5FFFFh		3	03000h	03FFFh	
	⋮	⋮	⋮		2	02000h	02FFFh	
	80	50000h	50FFFh		1	01000h	01FFFh	
4	79	4F000h	4FFFFh		0	00000h	00FFFh	
	⋮	⋮	⋮					
	64	40000h	40FFFh					

6 Instructions

All instructions, addresses and data are shifted in and out of the device, most significant bit first.

Serial Data input(s) DQ0 (DQ1) is (are) sampled on the first rising edge of Serial Clock (C) after Chip Select (\bar{S}) is driven Low. Then, the one-byte instruction code must be shifted in to the device, most significant bit first, on Serial Data input(s) DQ0 (DQ1), each bit being latched on the rising edges of Serial Clock (C).

The instruction set is listed in [Table 5](#).

Every instruction sequence starts with a one-byte instruction code. Depending on the instruction, this might be followed by address bytes, or by data bytes, or by both or none.

In the case of a Read Data Bytes (READ), Read Data Bytes at higher speed (FAST_READ), Dual Output Fast Read (DOFR), Read OTP (ROTP), Read Lock Registers (RDLR), Read Status Register (RDSR), Read Identification (RDID) or Release from Deep Power-down (RDP) instruction, the shifted-in instruction sequence is followed by a data-out sequence. Chip Select (\bar{S}) can be driven High after any bit of the data-out sequence is being shifted out.

In the case of a Page Program (PP), Program OTP (POTP), Dual Input Fast Program (DIFP), Subsector Erase (SSE), Sector Erase (SE), Bulk Erase (BE), Write Status Register (WRSR), Write to Lock Register (WRLR), Write Enable (WREN), Write Disable (WRDI) or Deep Power-down (DP) instruction, Chip Select (\bar{S}) must be driven High exactly at a byte boundary, otherwise the instruction is rejected, and is not executed. That is, Chip Select (\bar{S}) must be driven High when the number of clock pulses after Chip Select (\bar{S}) being driven Low is an exact multiple of eight.

All attempts to access the memory array during a Write Status Register cycle, Program cycle or Erase cycle are ignored, and the internal Write Status Register cycle, Program cycle or Erase cycle continues unaffected.

Table 5. Instruction set

Instruction	Description	One-byte instruction code	Address bytes	Dummy bytes	Data bytes	
WREN	Write Enable	0000 0110	06h	0	0	
WRDI	Write Disable	0000 0100	04h	0	0	
RDID	Read Identification	1001 1111	9Fh	0	0	1 to 20
		1001 1110	9Eh	0	0	1 to 3
RDSR	Read Status Register	0000 0101	05h	0	0	1 to ∞
WRSR	Write Status Register	0000 0001	01h	0	0	1
WRLR	Write to Lock Register	1110 0101	E5h	3	0	1
RDLR	Read Lock Register	1110 1000	E8h	3	0	1
READ	Read Data Bytes	0000 0011	03h	3	0	1 to ∞
FAST_READ	Read Data Bytes at higher speed	0000 1011	0Bh	3	1	1 to ∞
DOFR	Dual Output Fast Read	0011 1011	3Bh	3	1	1 to ∞

Table 5. Instruction set

Instruction	Description	One-byte instruction code	Address bytes	Dummy bytes	Data bytes	
ROTP	Read OTP (Read 64 bytes of OTP area)	0100 1011	4Bh	3	1	1 to 65
POTP	Program OTP (Program 64 bytes of OTP area)	0100 0010	42h	3	0	1 to 65
PP	Page Program	0000 0010	02h	3	0	1 to 256
DIFP	Dual Input Fast Program	1010 0010	A2h	3	0	1 to 256
SSE	Subsector Erase	0010 0000	20h	3	0	0
SE	Sector Erase	1101 1000	D8h	3	0	0
BE	Bulk Erase	1100 0111	C7h	0	0	0
DP	Deep Power-down	1011 1001	B9h	0	0	0
RDP	Release from Deep Power-down	1010 1011	ABh	0	0	0

6.1 Write Enable (WREN)

The Write Enable (WREN) instruction ([Figure 8](#)) sets the Write Enable Latch (WEL) bit.

The Write Enable Latch (WEL) bit must be set prior to every Page Program (PP), Dual Input Fast Program (DIFP), Program OTP (POTP), Write to Lock Register (WRLR), Subsector Erase (SSE), Sector Erase (SE), Bulk Erase (BE) and Write Status Register (WRSR) instruction.

The Write Enable (WREN) instruction is entered by driving Chip Select (\bar{S}) Low, sending the instruction code, and then driving Chip Select (\bar{S}) High.

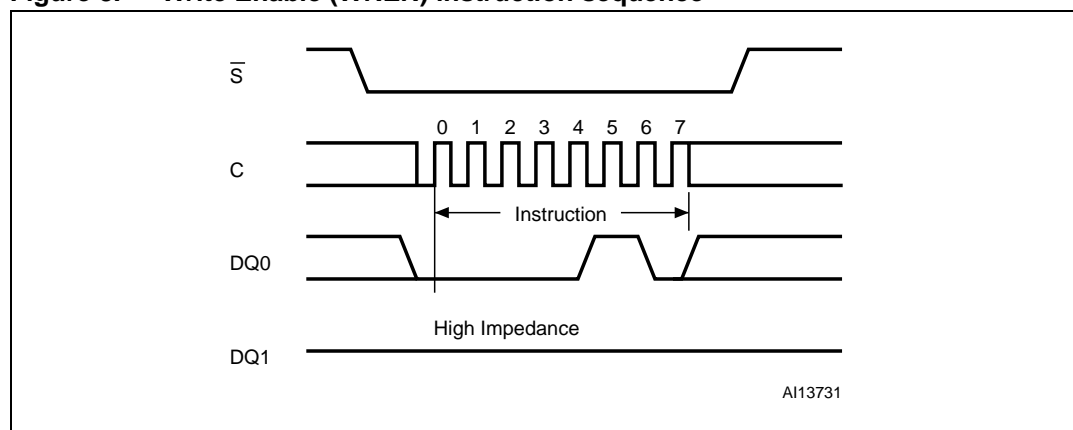
Figure 8. Write Enable (WREN) instruction sequence

6.2 Write Disable (WRDI)

The Write Disable (WRDI) instruction ([Figure 9](#)) resets the Write Enable Latch (WEL) bit.

The Write Disable (WRDI) instruction is entered by driving Chip Select (\bar{S}) Low, sending the instruction code, and then driving Chip Select (\bar{S}) High.

The Write Enable Latch (WEL) bit is reset under the following conditions:

- Power-up
- Write Disable (WRDI) instruction completion
- Write Status Register (WRSR) instruction completion
- Write to Lock Register (WRLR) instruction completion
- Page Program (PP) instruction completion
- Dual Input Fast Program (DIFP) instruction completion
- Program OTP (POTP) instruction completion
- Subsector Erase (SSE) instruction completion
- Sector Erase (SE) instruction completion
- Bulk Erase (BE) instruction completion

Figure 9. Write Disable (WRDI) instruction sequence

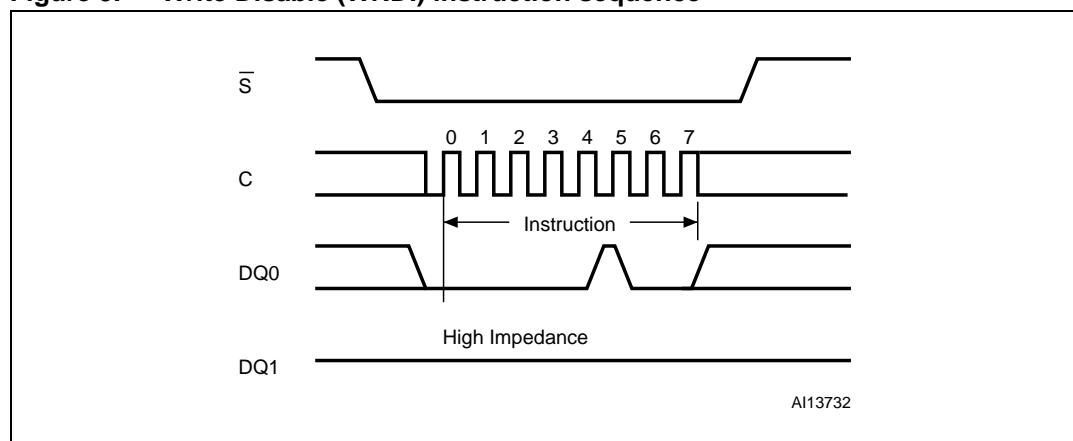

6.3 Read Identification (RDID)

The Read Identification (RDID) instruction allows to read the device identification data:

- Manufacturer identification (1 byte)
- Device identification (2 bytes)
- A Unique ID code (UID) (17 bytes, of which 16 available upon customer request).

The manufacturer identification is assigned by JEDEC, and has the value 20h. The device identification is assigned by the device manufacturer, and indicates the memory type in the first byte (71h), and the memory capacity of the device in the second byte (15h). The UID contains the length of the following data in the first byte (set to 10h) and 16 bytes of the optional Customized Factory Data (CFD) content. The CFD bytes are read-only and can be programmed with customers data upon their demand. If the customers do not make requests, the devices are shipped with all the CFD bytes programmed to zero (00h).

See [Section 12: Ordering information on page 62](#) for CFD programmed devices.

Any Read Identification (RDID) instruction while an Erase or Program cycle is in progress, is not decoded, and has no effect on the cycle that is in progress.

The Read Identification (RDID) instruction should not be issued while the device is in Deep Power-down mode.

The device is first selected by driving Chip Select (\bar{S}) Low. Then, the 8-bit instruction code for the instruction is shifted in. After this, the 24-bit device identification, stored in the memory, the 8-bit CFD length followed by 16 bytes of CFD content will be shifted out on Serial Data output (DQ1). Each bit is shifted out during the falling edge of Serial Clock (C).

The instruction sequence is shown in [Figure 10](#).

The Read Identification (RDID) instruction is terminated by driving Chip Select (\bar{S}) High at any time during data output.

When Chip Select (\bar{S}) is driven High, the device is put in the Standby Power mode. Once in the Standby Power mode, the device waits to be selected, so that it can receive, decode and execute instructions.

Table 6. Read Identification (RDID) data-out sequence

Manufacturer identification	Device identification		UID	
	Memory type	Memory capacity	CFD length	CFD content
20h	71h	15h	10h	16 bytes

Figure 10. Read Identification (RDID) instruction sequence and data-out sequence

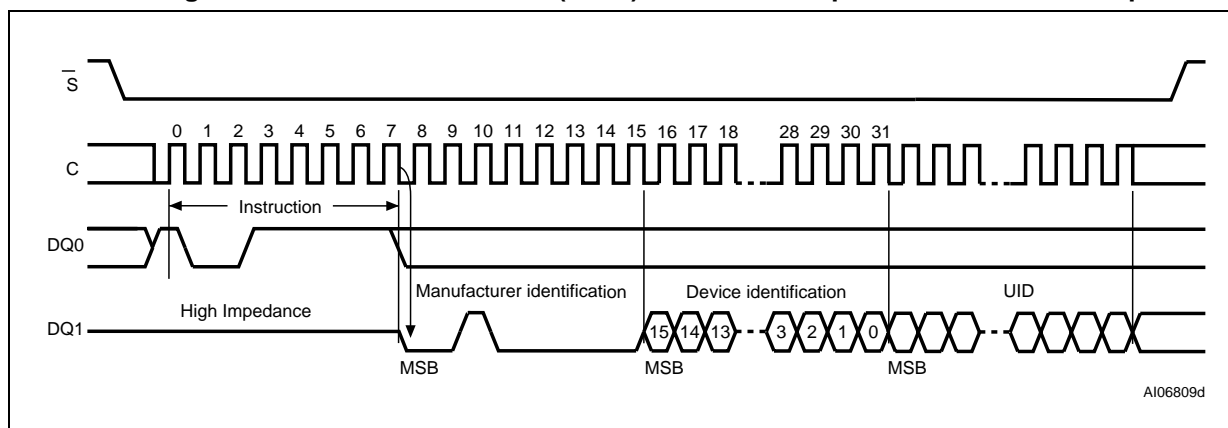

6.4 Read Status Register (RDSR)

The Read Status Register (RDSR) instruction allows the Status Register to be read. The Status Register may be read at any time, even while a Program, Erase or Write Status Register cycle is in progress. When one of these cycles is in progress, it is recommended to check the Write In Progress (WIP) bit before sending a new instruction to the device. It is also possible to read the Status Register continuously, as shown in [Figure 11](#).

Table 7. Status Register format

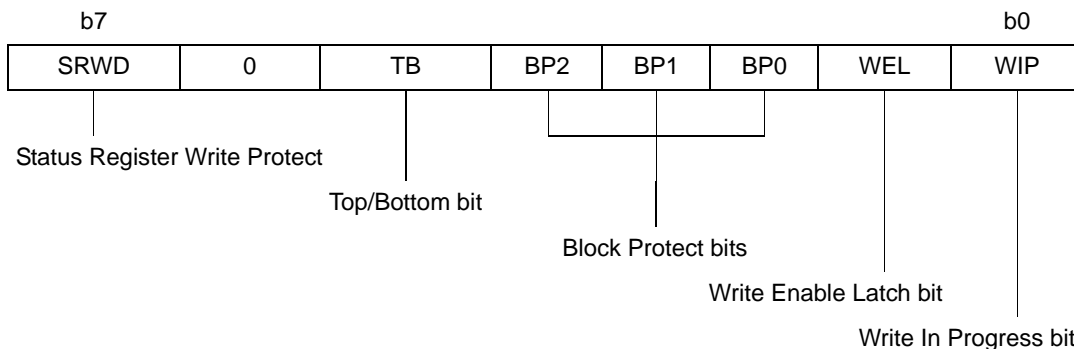

The status and control bits of the Status Register are as follows:

6.4.1 WIP bit

The Write In Progress (WIP) bit indicates whether the memory is busy with a Write Status Register, Program or Erase cycle. When set to 1, such a cycle is in progress, when reset to 0 no such cycle is in progress.

6.4.2 WEL bit

The Write Enable Latch (WEL) bit indicates the status of the internal Write Enable Latch. When set to 1 the internal Write Enable Latch is set, when set to 0 the internal Write Enable Latch is reset and no Write Status Register, Program or Erase instruction is accepted.

6.4.3 BP2, BP1, BP0 bits

The Block Protect (BP2, BP1, BP0) bits are non-volatile. They define the size of the area to be software protected against Program and Erase instructions. These bits are written with the Write Status Register (WRSR) instruction. When one or more of the Block Protect (BP2, BP1, BP0) bits is set to 1, the relevant memory area (as defined in [Table 3](#)) becomes protected against Page Program (PP) and Sector Erase (SE) instructions. The Block Protect (BP2, BP1, BP0) bits can be written provided that the Hardware Protected mode has not been set. The Bulk Erase (BE) instruction is executed if, and only if, all Block Protect (BP2, BP1, BP0) bits are 0.

6.4.4 TB bit

The Top/Bottom (TB) bit is non-volatile. It can be set and reset with the Write Status Register (WRSR) instruction provided that the Write Enable (WREN) instruction has been issued. The Top/Bottom (TB) bit is used in conjunction with the Block Protect (BP0, BP1, BP2) bits to determine if the protected area defined by the Block Protect bits starts from the top or the bottom of the memory array:

- When TB is reset to '0' (default value), the area protected by the Block Protect bits starts from the top of the memory array (see [Table 3: Protected area sizes](#))
- When TB is set to '1', the area protected by the Block Protect bits starts from the bottom of the memory array (see [Table 3: Protected area sizes](#))

The TB bit cannot be written when the SRWD bit is set to '1' and the \overline{W} pin is driven Low.

6.4.5 SRWD bit

The Status Register Write Disable (SRWD) bit is operated in conjunction with the Write Protect (\overline{W}/V_{PP}) signal. The Status Register Write Disable (SRWD) bit and the Write Protect (\overline{W}/V_{PP}) signal allow the device to be put in the hardware protected mode (when the Status Register Write Disable (SRWD) bit is set to '1', and Write Protect (\overline{W}/V_{PP}) is driven Low). In this mode, the non-volatile bits of the Status Register (SRWD, BP2, BP1, BP0) become read-only bits and the Write Status Register (WRSR) instruction is no longer accepted for execution.

Figure 11. Read Status Register (RDSR) instruction sequence and data-out sequence

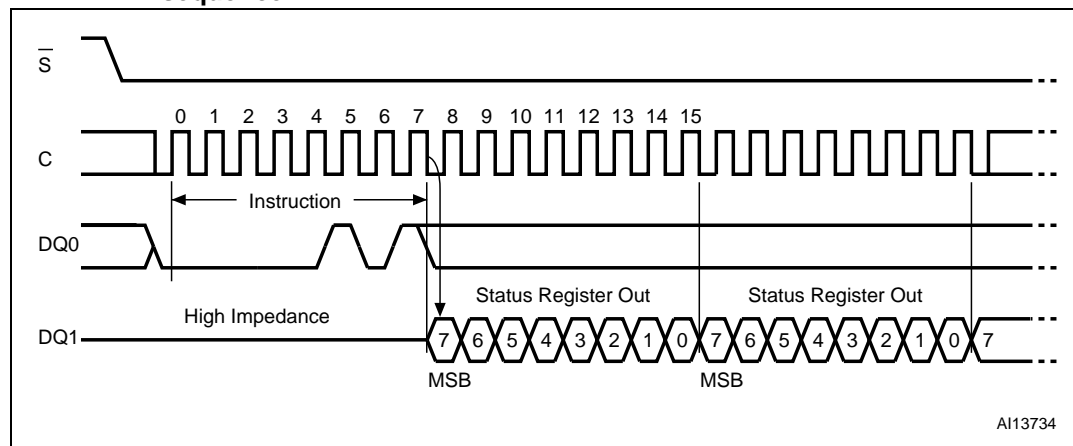

6.5 Write Status Register (WRSR)

The Write Status Register (WRSR) instruction allows new values to be written to the Status Register. Before it can be accepted, a Write Enable (WREN) instruction must previously have been executed. After the Write Enable (WREN) instruction has been decoded and executed, the device sets the Write Enable Latch (WEL).

The Write Status Register (WRSR) instruction is entered by driving Chip Select (\overline{S}) Low, followed by the instruction code and the data byte on Serial Data input (DQ0).

The instruction sequence is shown in [Figure 12](#).

The Write Status Register (WRSR) instruction has no effect on b6, b1 and b0 of the Status Register. b6 is always read as '0'.

Chip Select (\overline{S}) must be driven High after the eighth bit of the data byte has been latched in. If not, the Write Status Register (WRSR) instruction is not executed. As soon as Chip Select (\overline{S}) is driven High, the self-timed Write Status Register cycle (whose duration is t_W) is initiated. While the Write Status Register cycle is in progress, the Status Register may still be read to check the value of the Write In Progress (WIP) bit. The Write In Progress (WIP) bit is 1 during the self-timed Write Status Register cycle, and is 0 when it is completed. When the cycle is completed, the Write Enable Latch (WEL) is reset.

The Write Status Register (WRSR) instruction allows the user to change the values of the Block Protect (BP2, BP1, BP0) bits, to define the size of the area that is to be treated as read-only, as defined in [Table 3](#). The Write Status Register (WRSR) instruction also allows the user to set and reset the Status Register Write Disable (SRWD) bit in accordance with

the Write Protect ($\overline{W/V_{PP}}$) signal. The Status Register Write Disable (SRWD) bit and Write Protect ($\overline{W/V_{PP}}$) signal allow the device to be put in the hardware protected mode (HPM). The Write Status Register (WRSR) instruction is not executed once the hardware protected mode (HPM) is entered.

Figure 12. Write Status Register (WRSR) instruction sequence

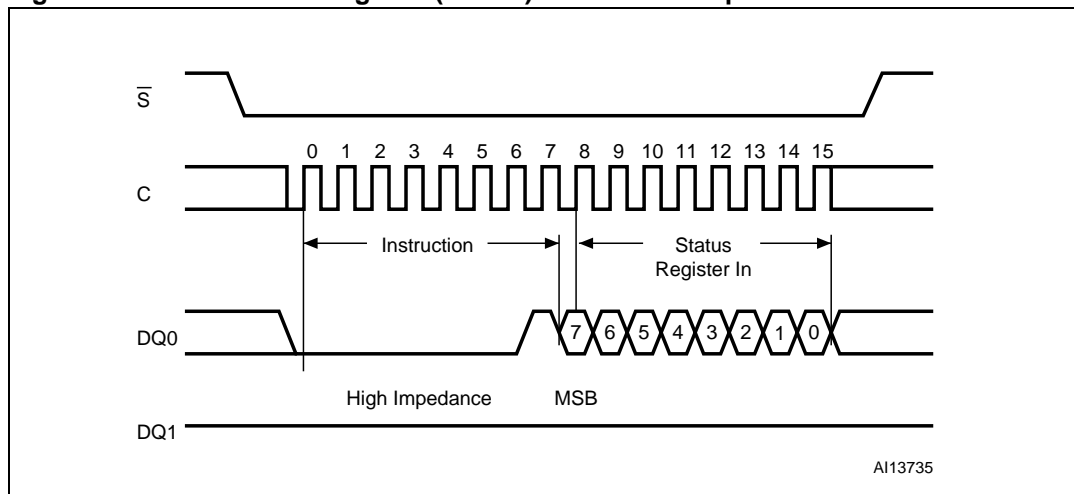

Table 8. Protection modes

$\overline{W/V_{PP}}$ signal	SRWD bit	Mode	Write Protection of the Status Register	Memory content	
				Protected area ⁽¹⁾	Unprotected area ⁽¹⁾
1	0	Software protected (SPM)	Status Register is Writable (if the WREN instruction has set the WEL bit) The values in the SRWD, BP2, BP1 and BP0 bits can be changed	Protected against Page Program, Sector Erase and Bulk Erase	Ready to accept Page Program and Sector Erase instructions
0	0				
1	1	Hardware protected (HPM)	Status Register is hardware write protected The values in the SRWD, BP2, BP1 and BP0 bits cannot be changed	Protected against Page Program, Sector Erase and Bulk Erase	Ready to accept Page Program and Sector Erase instructions

1. As defined by the values in the Block Protect (BP2, BP1, BP0) bits of the Status Register, as shown in [Table 3](#).

The protection features of the device are summarized in [Table 8](#).

When the Status Register Write Disable (SRWD) bit of the Status Register is 0 (its initial delivery state), it is possible to write to the Status Register provided that the Write Enable Latch (WEL) bit has previously been set by a Write Enable (WREN) instruction, regardless of the whether Write Protect ($\overline{W/V_{PP}}$) is driven High or Low.

When the Status Register Write Disable (SRWD) bit of the Status Register is set to 1, two cases need to be considered, depending on the state of Write Protect (\overline{W}/V_{PP}):

- If Write Protect (\overline{W}/V_{PP}) is driven High, it is possible to write to the Status Register provided that the Write Enable Latch (WEL) bit has previously been set by a Write Enable (WREN) instruction.
- If Write Protect (\overline{W}/V_{PP}) is driven Low, it is not possible to write to the Status Register *even* if the Write Enable Latch (WEL) bit has previously been set by a Write Enable (WREN) instruction. (Attempts to write to the Status Register are rejected, and are not accepted for execution). As a consequence, all the data bytes in the memory area that are software protected (SPM) by the Block Protect (BP2, BP1, BP0) bits of the Status Register, are also hardware protected against data modification.

Regardless of the order of the two events, the Hardware Protected mode (HPM) can be entered:

- by setting the Status Register Write Disable (SRWD) bit after driving Write Protect (\overline{W}/V_{PP}) Low
- or by driving Write Protect (\overline{W}/V_{PP}) Low after setting the Status Register Write Disable (SRWD) bit.

The only way to exit the Hardware Protected mode (HPM) once entered is to pull Write Protect (\overline{W}/V_{PP}) High.

If Write Protect (\overline{W}/V_{PP}) is permanently tied High, the Hardware Protected mode (HPM) can never be activated, and only the Software Protected mode (SPM), using the Block Protect (BP2, BP1, BP0) bits of the Status Register, can be used.

6.6 Read Data Bytes (READ)

The device is first selected by driving Chip Select (\overline{S}) Low. The instruction code for the Read Data Bytes (READ) instruction is followed by a 3-byte address (A23-A0), each bit being latched-in during the rising edge of Serial Clock (C). Then the memory contents, at that address, is shifted out on Serial Data output (DQ1), each bit being shifted out, at a maximum frequency f_R , during the falling edge of Serial Clock (C).

The instruction sequence is shown in [Figure 13](#).

The first byte addressed can be at any location. The address is automatically incremented to the next higher address after each byte of data is shifted out. The whole memory can, therefore, be read with a single Read Data Bytes (READ) instruction. When the highest address is reached, the address counter rolls over to 000000h, allowing the read sequence to be continued indefinitely.

The Read Data Bytes (READ) instruction is terminated by driving Chip Select (\overline{S}) High. Chip Select (\overline{S}) can be driven High at any time during data output. Any Read Data Bytes (READ) instruction, while an Erase, Program or Write cycle is in progress, is rejected without having any effects on the cycle that is in progress.

Figure 13. Read Data Bytes (READ) instruction sequence and data-out sequence

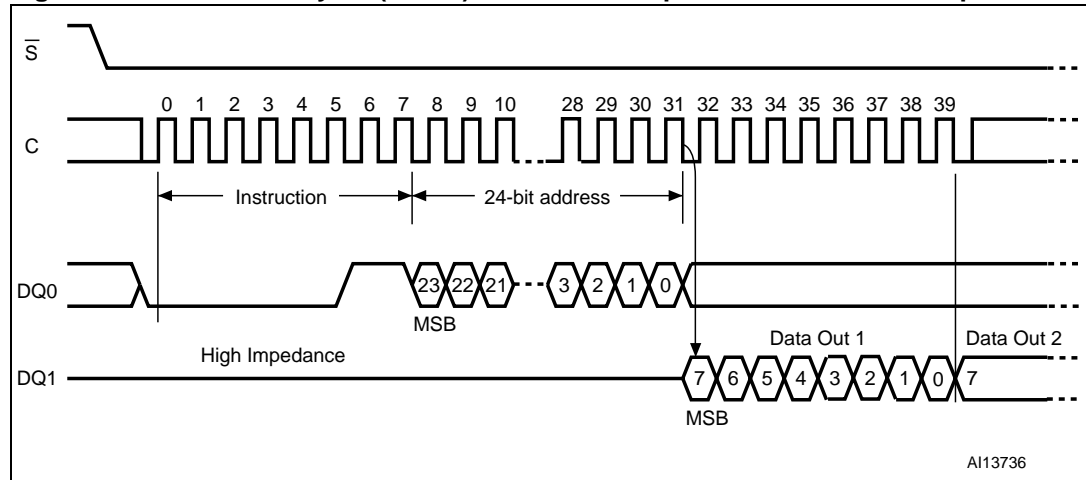

1. Address bits A23 to A22 are Don't care.

6.7 Read Data Bytes at higher speed (FAST_READ)

The device is first selected by driving Chip Select (\overline{S}) Low. The instruction code for the Read Data Bytes at higher speed (FAST_READ) instruction is followed by a 3-byte address (A23-A0) and a dummy byte, each bit being latched-in during the rising edge of Serial Clock (C). Then the memory contents, at that address, are shifted out on Serial Data output (DQ1) at a maximum frequency f_C , during the falling edge of Serial Clock (C).

The instruction sequence is shown in [Figure 14](#).

The first byte addressed can be at any location. The address is automatically incremented to the next higher address after each byte of data is shifted out. The whole memory can, therefore, be read with a single Read Data Bytes at higher speed (FAST_READ) instruction. When the highest address is reached, the address counter rolls over to 000000h, allowing the read sequence to be continued indefinitely.

The Read Data Bytes at higher speed (FAST_READ) instruction is terminated by driving Chip Select (\overline{S}) High. Chip Select (\overline{S}) can be driven High at any time during data output. Any Read Data Bytes at higher speed (FAST_READ) instruction, while an Erase, Program or Write cycle is in progress, is rejected without having any effects on the cycle that is in progress.

Figure 14. Read Data Bytes at higher speed (FAST_READ) instruction sequence and data-out sequence

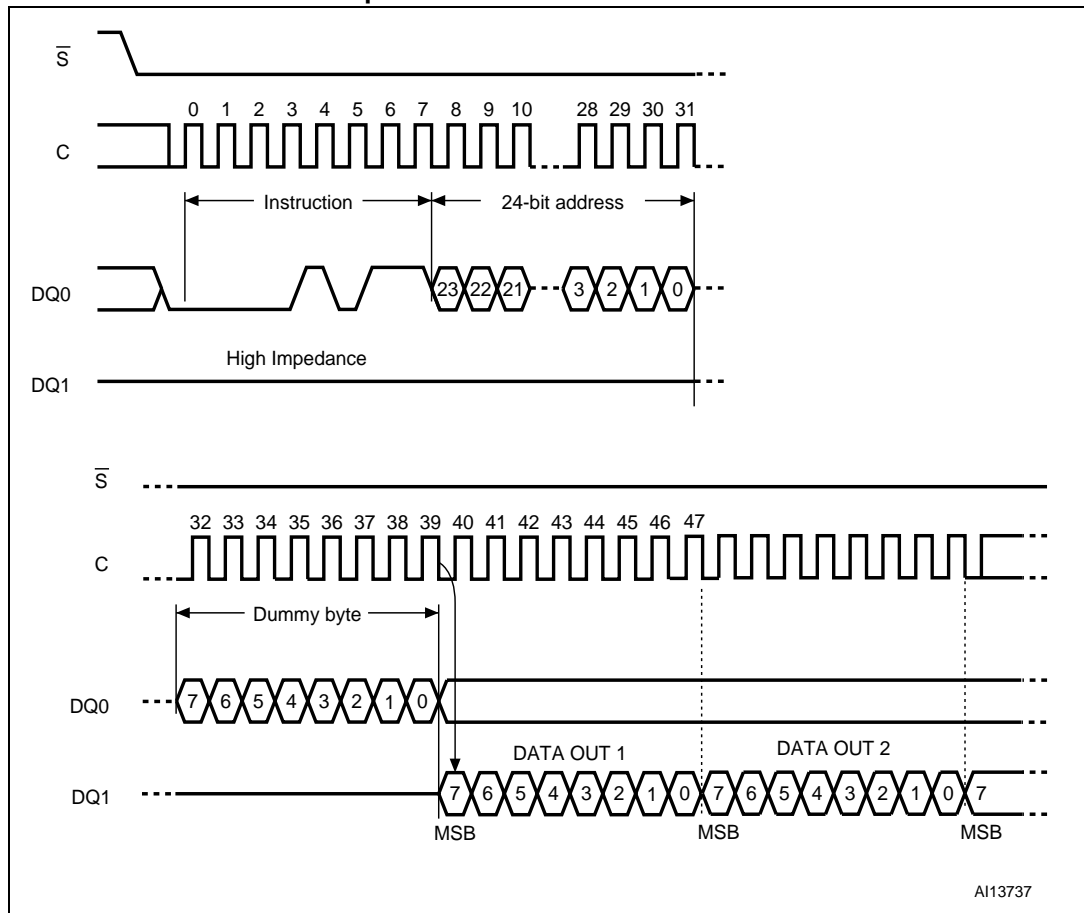

1. Address bits A23 to A22 are Don't care.

6.8 Dual Output Fast Read (DOFR)

The Dual Output Fast Read (DOFR) instruction is very similar to the Read Data Bytes at higher speed (FAST_READ) instruction, except that the data are shifted out on two pins (pin DQ0 and pin DQ1) instead of only one. Outputting the data on two pins instead of one doubles the data transfer bandwidth compared to the Read Data Bytes at higher speed (FAST_READ) instruction.

The device is first selected by driving Chip Select (\bar{S}) Low. The instruction code for the Dual Output Fast Read instruction is followed by a 3-byte address (A23-A0) and a dummy byte, each bit being latched-in during the rising edge of Serial Clock (C). Then the memory contents, at that address, are shifted out on DQ0 and DQ1 at a maximum frequency f_C , during the falling edge of Serial Clock (C).

The instruction sequence is shown in [Figure 15](#).

The first byte addressed can be at any location. The address is automatically incremented to the next higher address after each byte of data is shifted out on DQ0 and DQ1. The whole memory can, therefore, be read with a single Dual Output Fast Read (DOFR) instruction.

When the highest address is reached, the address counter rolls over to 00 0000h, so that the read sequence can be continued indefinitely.

Figure 15. Dual Output Fast Read instruction sequence

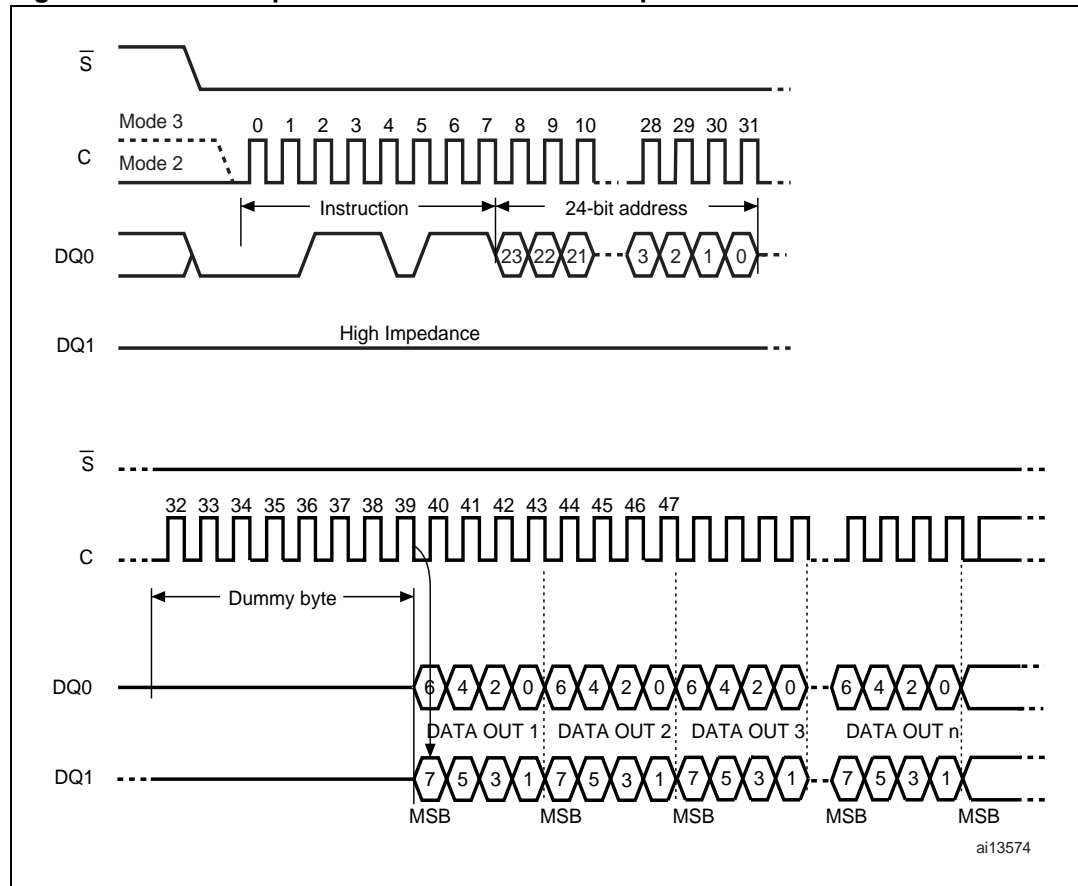

1. A23 to A22 are Don't care.

6.9 Read Lock Register (RDLR)

The device is first selected by driving Chip Select (\bar{S}) Low. The instruction code for the Read Lock Register (RDLR) instruction is followed by a 3-byte address (A23-A0) pointing to any location inside the concerned sector. Each address bit is latched-in during the rising edge of Serial Clock (C). Then the value of the Lock Register is shifted out on Serial Data output (DQ1), each bit being shifted out, at a maximum frequency f_C , during the falling edge of Serial Clock (C).

The instruction sequence is shown in [Figure 16](#).

The Read Lock Register (RDLR) instruction is terminated by driving Chip Select (\bar{S}) High at any time during data output.

Any Read Lock Register (RDLR) instruction, while an Erase, Program or Write cycle is in progress, is rejected without having any effects on the cycle that is in progress.

Table 9. Lock Register out⁽¹⁾

Bit	Bit name	Value	Function
b7-b2	Reserved		
b1	Sector Lock Down	'1'	The Write Lock and Lock Down bits cannot be changed. Once a '1' is written to the Lock Down bit it cannot be cleared to '0', except by a power-up.
		'0'	The Write Lock and Lock Down bits can be changed by writing new values to them.
b0	Sector Write Lock	'1'	Write, Program and Erase operations in this sector will not be executed. The memory contents will not be changed.
		'0'	Write, Program and Erase operations in this sector are executed and will modify the sector contents.

1. Values of (b1, b0) after power-up are defined in [Section 7: Power-up and power-down](#).

Figure 16. Read Lock Register (RDLR) instruction sequence and data-out sequence

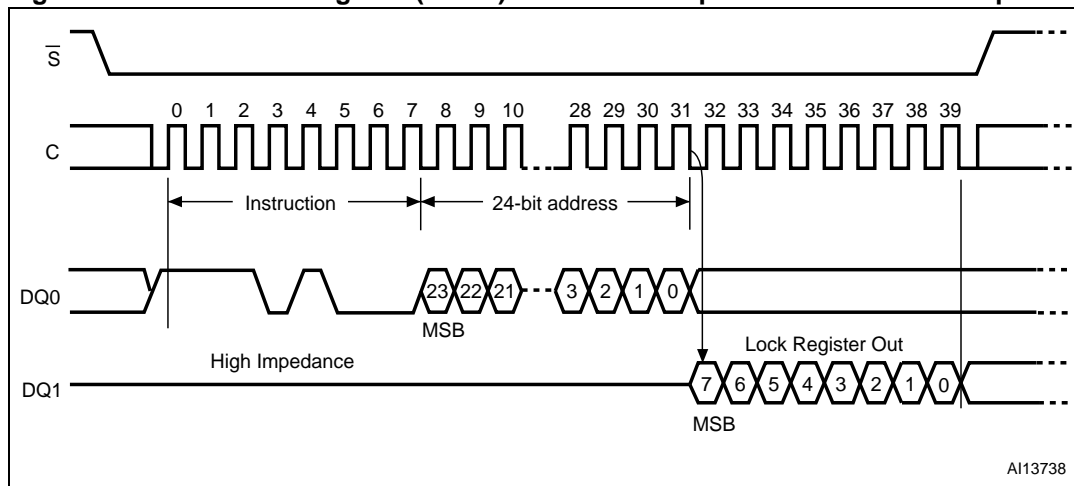

6.10 Read OTP (ROTP)

The device is first selected by driving Chip Select (\bar{S}) Low. The instruction code for the Read OTP (ROTP) instruction is followed by a 3-byte address (A23- A0) and a dummy byte. Each bit is latched in on the rising edge of Serial Clock (C).

Then the memory contents at that address are shifted out on Serial Data output (DQ1). Each bit is shifted out at the maximum frequency, f_{Cmax} , on the falling edge of Serial Clock (C). The instruction sequence is shown in [Figure 17](#).

The address is automatically incremented to the next higher address after each byte of data is shifted out.

There is no rollover mechanism with the Read OTP (ROTP) instruction. This means that the Read OTP (ROTP) instruction must be sent with a maximum of 65 bytes to read, since once the 65th byte has been read, the same (65th) byte keeps being read on the DQ1 pin.

The Read OTP (ROTP) instruction is terminated by driving Chip Select (\bar{S}) High. Chip Select (\bar{S}) can be driven High at any time during data output. Any Read OTP (ROTP)

instruction issued while an Erase, Program or Write cycle is in progress, is rejected without having any effect on the cycle that is in progress.

Figure 17. Read OTP (ROTP) instruction and data-out sequence

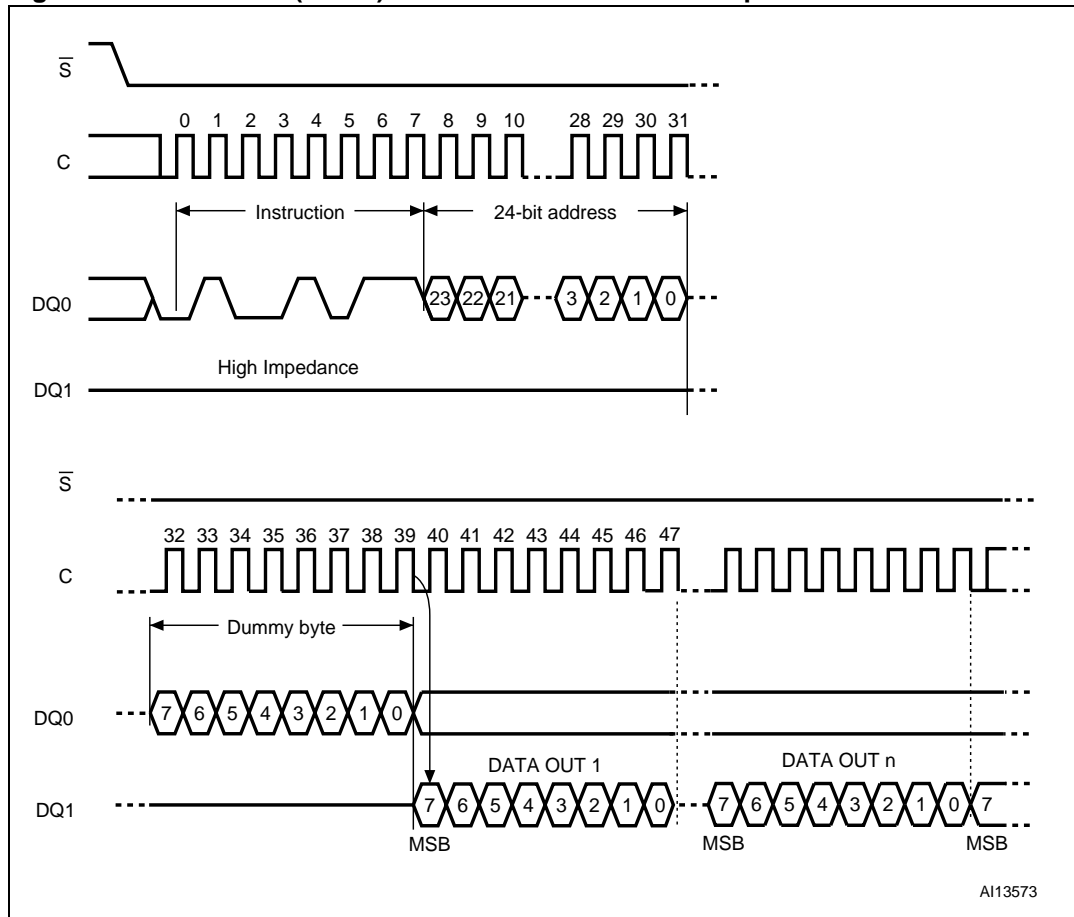

1. A23 to A7 are Don't care.
2. $1 \leq n \leq 65$.

6.11 Page Program (PP)

The Page Program (PP) instruction allows bytes to be programmed in the memory (changing bits from 1 to 0). Before it can be accepted, a Write Enable (WREN) instruction must previously have been executed. After the Write Enable (WREN) instruction has been decoded, the device sets the Write Enable Latch (WEL).

The Page Program (PP) instruction is entered by driving Chip Select (\bar{S}) Low, followed by the instruction code, three address bytes and at least one data byte on Serial Data input (DQ0). If the 8 least significant address bits (A7-A0) are not all zero, all transmitted data that goes beyond the end of the current page are programmed from the start address of the same page (from the address whose 8 least significant bits (A7-A0) are all zero). Chip Select (\bar{S}) must be driven Low for the entire duration of the sequence.

The instruction sequence is shown in [Figure 18](#).

If more than 256 bytes are sent to the device, previously latched data are discarded and the last 256 data bytes are guaranteed to be programmed correctly within the same page. If less than 256 data bytes are sent to device, they are correctly programmed at the requested addresses without having any effects on the other bytes of the same page.

For optimized timings, it is recommended to use the Page Program (PP) instruction to program all consecutive targeted bytes in a single sequence versus using several Page Program (PP) sequences with each containing only a few bytes (see [Table 18: AC characteristics](#)).

Chip Select (\bar{S}) must be driven High after the eighth bit of the last data byte has been latched in, otherwise the Page Program (PP) instruction is not executed.

As soon as Chip Select (\bar{S}) is driven High, the self-timed Page Program cycle (whose duration is t_{PP}) is initiated. While the Page Program cycle is in progress, the Status Register may be read to check the value of the Write In Progress (WIP) bit. The Write In Progress (WIP) bit is 1 during the self-timed Page Program cycle, and is 0 when it is completed. At some unspecified time before the cycle is completed, the Write Enable Latch (WEL) bit is reset.

A Page Program (PP) instruction applied to a page which is protected by the Block Protect (BP2, BP1, BP0) bits (see [Table 3](#) and [Table 4](#)) is not executed.

Figure 18. Page Program (PP) instruction sequence

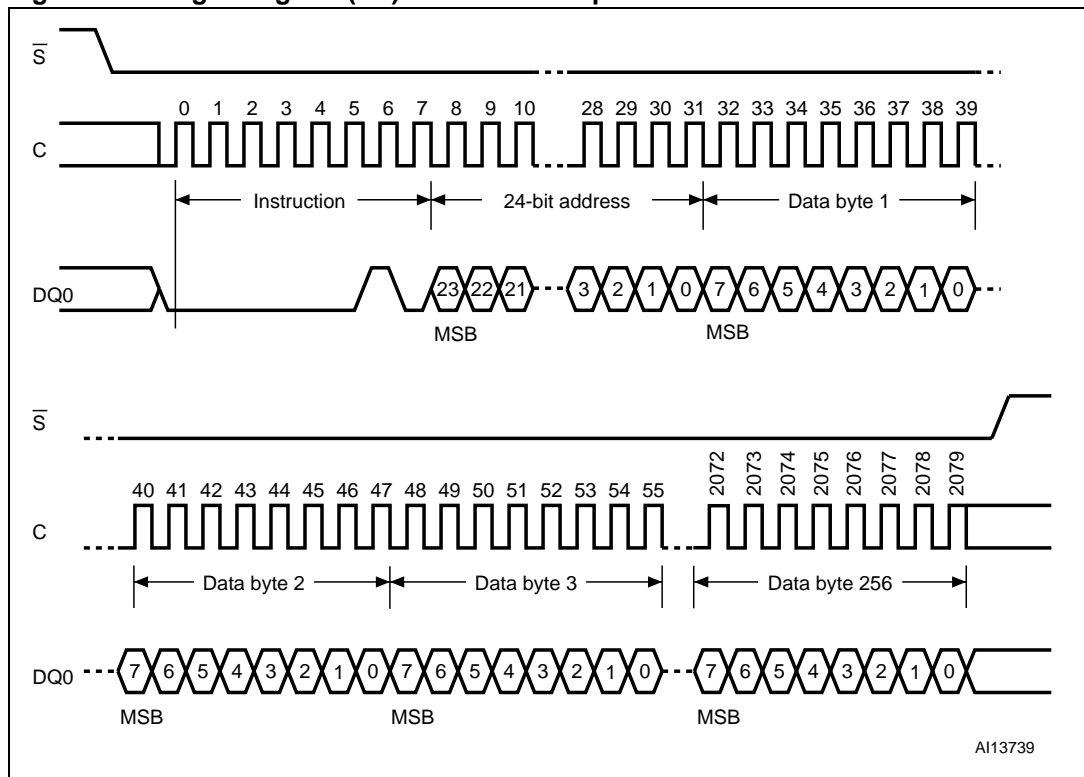

1. Address bits A23 to A22 are Don't care.

6.12 Dual Input Fast Program (DIFP)

The Dual Input Fast Program (DIFP) instruction is very similar to the Page Program (PP) instruction, except that the data are entered on two pins (pin DQ0 and pin DQ1) instead of only one. Inputting the data on two pins instead of one doubles the data transfer bandwidth compared to the Page Program (PP) instruction.

The Dual Input Fast Program (DIFP) instruction is entered by driving Chip Select (\overline{S}) Low, followed by the instruction code, three address bytes and at least one data byte on Serial Data input (DQ0).

If the 8 least significant address bits (A7-A0) are not all zero, all transmitted data that goes beyond the end of the current page are programmed from the start address of the same page (from the address whose 8 least significant bits (A7-A0) are all zero). Chip Select (\overline{S}) must be driven Low for the entire duration of the sequence.

The instruction sequence is shown in [Figure 19](#).

If more than 256 bytes are sent to the device, previously latched data are discarded and the last 256 data bytes are guaranteed to be programmed correctly within the same page. If less than 256 data bytes are sent to device, they are correctly programmed at the requested addresses without having any effects on the other bytes in the same page.

For optimized timings, it is recommended to use the Dual Input Fast Program (DIFP) instruction to program all consecutive targeted bytes in a single sequence rather to using several Dual Input Fast Program (DIFP) sequences each containing only a few bytes (see [Table 18: AC characteristics](#)).

Chip Select (\overline{S}) must be driven High after the eighth bit of the last data byte has been latched in, otherwise the Dual Input Fast Program (DIFP) instruction is not executed.

As soon as Chip Select (\overline{S}) is driven High, the self-timed Page Program cycle (whose duration is t_{pp}) is initiated. While the Dual Input Fast Program (DIFP) cycle is in progress, the Status Register may be read to check the value of the Write In Progress (WIP) bit. The Write In Progress (WIP) bit is 1 during the self-timed Page Program cycle, and 0 when it is completed. At some unspecified time before the cycle is completed, the Write Enable Latch (WEL) bit is reset.

A Dual Input Fast Program (DIFP) instruction applied to a page that is protected by the Block Protect (BP2, BP1, BP0) bits (see [Table 2](#) and [Table 3](#)) is not executed.

Figure 19. Dual Input Fast Program (DIFP) instruction sequence

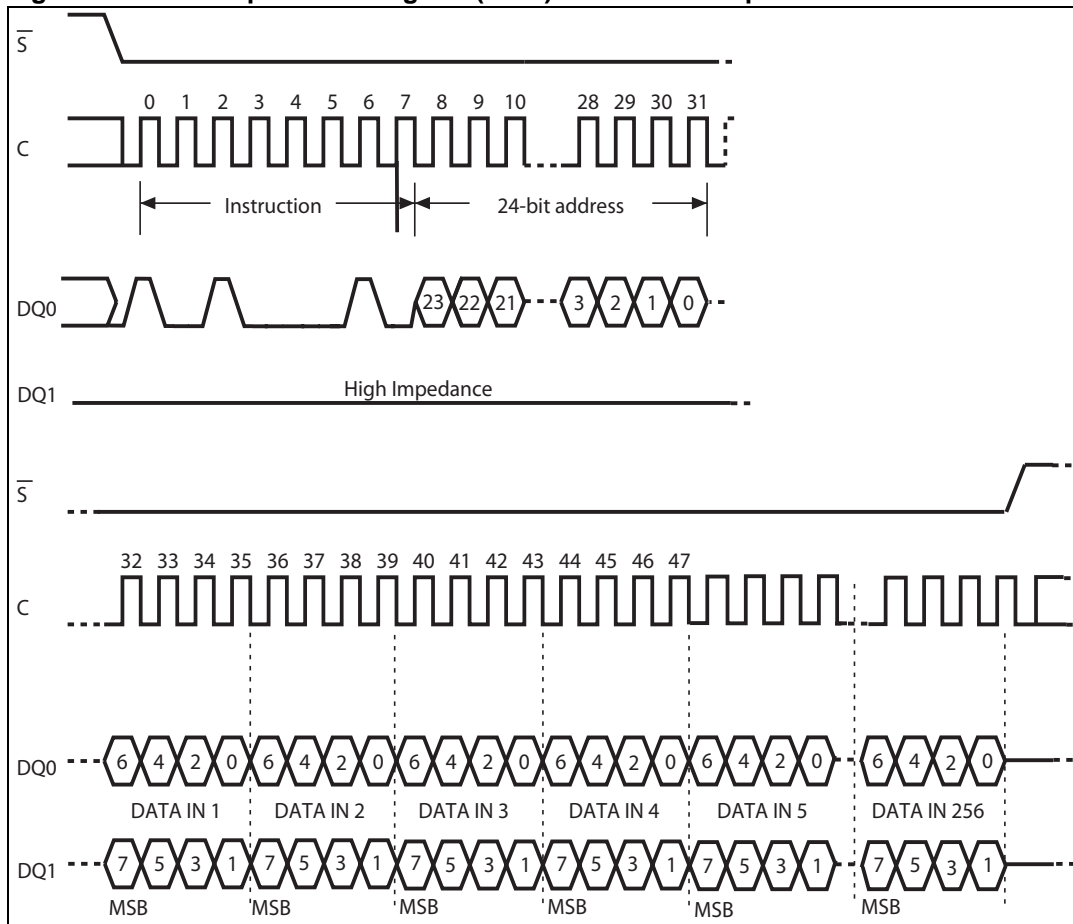

1. A23 to A22 are Don't care.

6.13 Program OTP instruction (POTP)

The Program OTP instruction (POTP) is used to program at most 64 bytes to the OTP memory area (by changing bits from 1 to 0, only). Before it can be accepted, a Write Enable (WREN) instruction must previously have been executed. After the Write Enable (WREN) instruction has been decoded, the device sets the Write Enable Latch (WEL) bit.

The Program OTP instruction is entered by driving Chip Select (\overline{S}) Low, followed by the instruction opcode, three address bytes and at least one data byte on Serial Data input (DQ0).

Chip Select (\overline{S}) must be driven High after the eighth bit of the last data byte has been latched in, otherwise the Program OTP instruction is not executed.

There is no rollover mechanism with the Program OTP (POTP) instruction. This means that the Program OTP (POTP) instruction must be sent with a maximum of 65 bytes to program, once all 65 bytes have been latched in, any following byte will be discarded.

The instruction sequence is shown in [Figure 20](#).

As soon as Chip Select (\overline{S}) is driven High, the self-timed Page Program cycle (whose duration is t_{pp}) is initiated. While the Program OTP cycle is in progress, the Status Register

may be read to check the value of the Write In Progress (WIP) bit. The Write In Progress (WIP) bit is 1 during the self-timed Program OTP cycle, and it is 0 when it is completed. At some unspecified time before the cycle is complete, the Write Enable Latch (WEL) bit is reset.

To lock the OTP memory:

Bit 0 of the OTP control byte, that is byte 64, (see [Figure 21](#)) is used to permanently lock the OTP memory array.

- When bits 3, 2, 1 and 0 of byte 64 = '1', the 64 bytes of the OTP memory array can be programmed.
- When bits 3, 2, 1, and 0 of byte 64 = '0', the 64 bytes of the OTP memory array are read-only and cannot be programmed anymore.

Once a bit of the OTP memory has been programmed to '0', it can no longer be set to '1'. Therefore, as soon as bit 0 of byte 64 (control byte) is set to '0', the 64 bytes of the OTP memory array become read-only in a permanent way.

Any Program OTP (POTP) instruction issued while an Erase, Program or Write cycle is in progress is rejected without having any effect on the cycle that is in progress.

Figure 20. Program OTP (POTP) instruction sequence

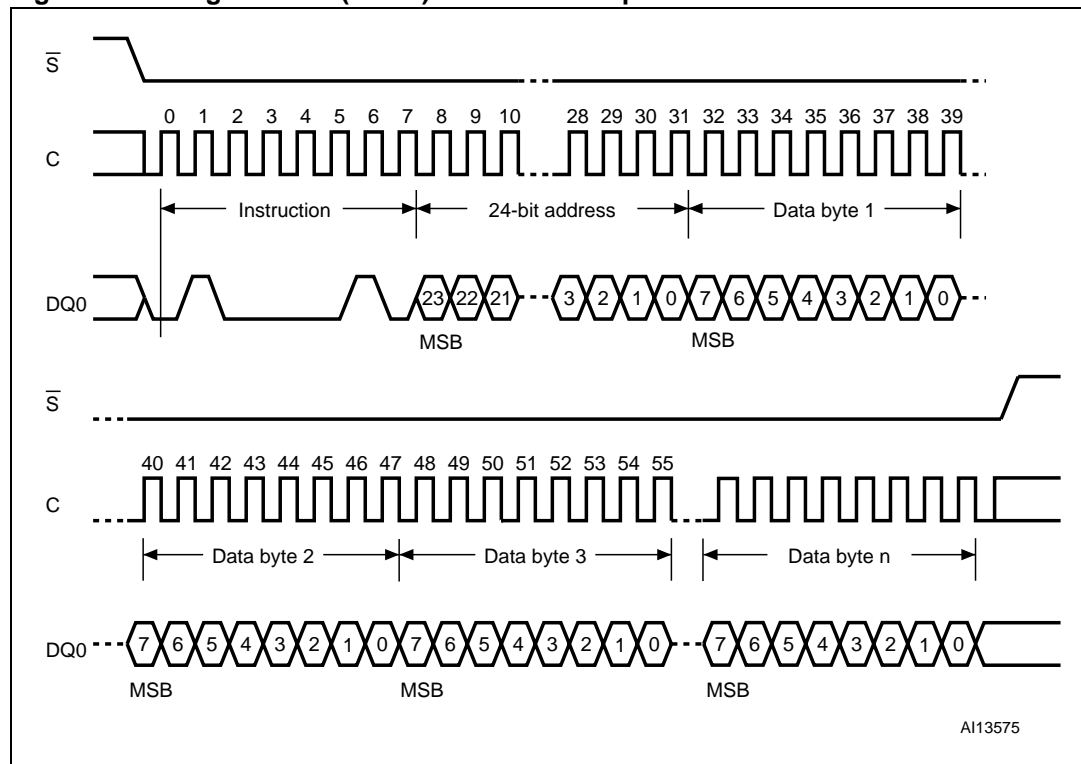

1. A23 to A7 are Don't care.
2. $1 \leq n \leq 65$

Figure 21. How to permanently lock the 64 OTP bytes

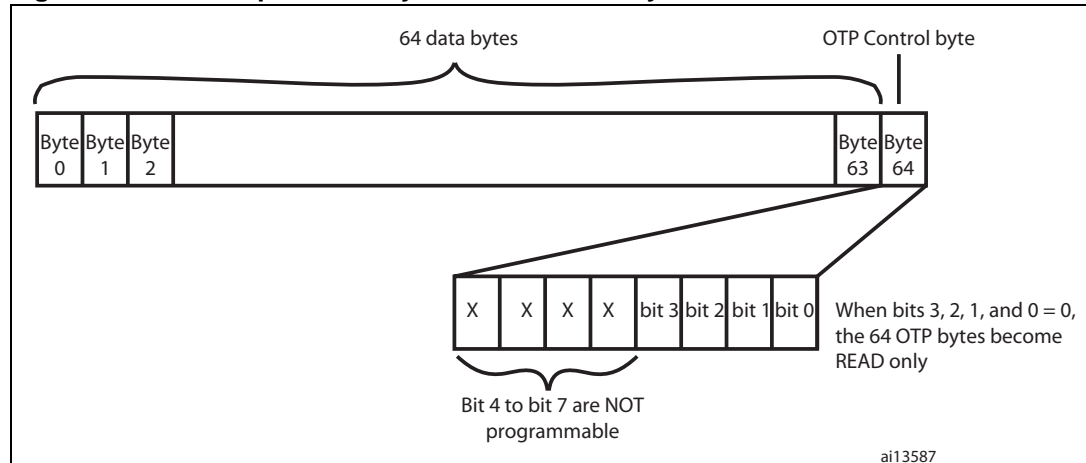

6.14 Write to Lock Register (WRLR)

The Write to Lock Register (WRLR) instruction allows bits to be changed in the Lock Registers. Before it can be accepted, a Write Enable (WREN) instruction must previously have been executed. After the Write Enable (WREN) instruction has been decoded, the device sets the Write Enable Latch (WEL).

The Write to Lock Register (WRLR) instruction is entered by driving Chip Select (\bar{S}) Low, followed by the instruction code, three address bytes (pointing to any address in the targeted sector and one data byte on Serial Data input (DQ0). The instruction sequence is shown in *Figure 22*. Chip Select (\bar{S}) must be driven High after the eighth bit of the data byte has been latched in, otherwise the Write to Lock Register (WRLR) instruction is not executed.

Lock Register bits are volatile, and therefore do not require time to be written. When the Write to Lock Register (WRLR) instruction has been successfully executed, the Write Enable Latch (WEL) bit is reset after a delay time less than t_{SHSL} minimum value.

Any Write to Lock Register (WRLR) instruction, while an Erase, Program or Write cycle is in progress, is rejected without having any effects on the cycle that is in progress.

Figure 22. Write to Lock Register (WRLR) instruction sequence

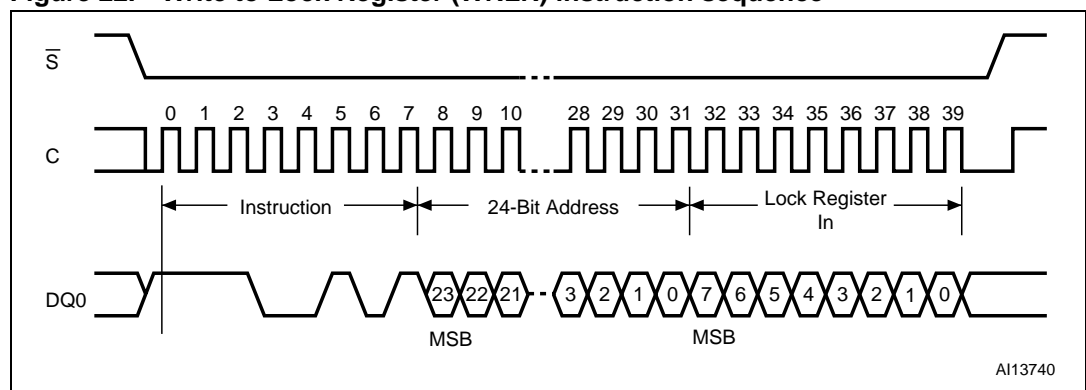

Table 10. Lock Register in⁽¹⁾

Sector	Bit	Value
All sectors	b7-b2	'0'
	b1	Sector Lock Down bit value (refer to Table 9)
	b0	Sector Write Lock bit value (refer to Table 9)

1. Values of (b1, b0) after power-up are defined in [Section 7: Power-up and power-down](#).

6.15 Subsector Erase (SSE)

The Subsector Erase (SSE) instruction sets to 1 (FFh) all bits inside the chosen subsector. Before it can be accepted, a Write Enable (WREN) instruction must previously have been executed. After the Write Enable (WREN) instruction has been decoded, the device sets the Write Enable Latch (WEL).

The Subsector Erase (SSE) instruction is entered by driving Chip Select (\bar{S}) Low, followed by the instruction code, and three address bytes on Serial Data input (DQ0). Any address inside the Subsector (see [Table 4](#)) is a valid address for the Subsector Erase (SSE) instruction. Chip Select (\bar{S}) must be driven Low for the entire duration of the sequence.

The instruction sequence is shown in [Figure 23](#).

Chip Select (\bar{S}) must be driven High after the eighth bit of the last address byte has been latched in, otherwise the Subsector Erase (SSE) instruction is not executed. As soon as Chip Select (\bar{S}) is driven High, the self-timed Subsector Erase cycle (whose duration is t_{SSE}) is initiated. While the Subsector Erase cycle is in progress, the Status Register may be read to check the value of the Write In Progress (WIP) bit. The Write In Progress (WIP) bit is 1 during the self-timed Subsector Erase cycle, and is 0 when it is completed. At some unspecified time before the cycle is complete, the Write Enable Latch (WEL) bit is reset.

A Subsector Erase (SSE) instruction issued to a sector that is hardware or software protected, is not executed.

Any Subsector Erase (SSE) instruction, while an Erase, Program or Write cycle is in progress, is rejected without having any effects on the cycle that is in progress.

Figure 23. Subsector Erase (SSE) instruction sequence

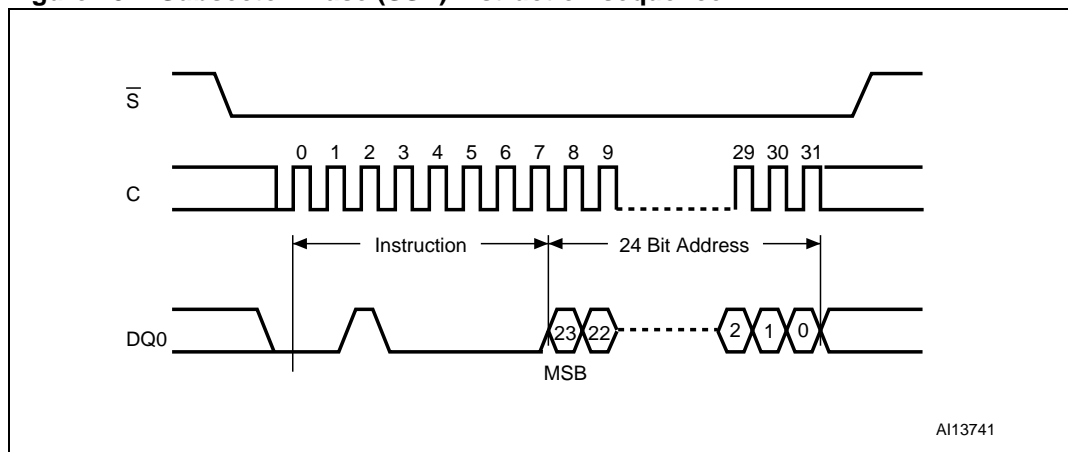

1. Address bits A23 to A22 are Don't care.

6.16 Sector Erase (SE)

The Sector Erase (SE) instruction sets to 1 (FFh) all bits inside the chosen sector. Before it can be accepted, a Write Enable (WREN) instruction must previously have been executed. After the Write Enable (WREN) instruction has been decoded, the device sets the Write Enable Latch (WEL).

The Sector Erase (SE) instruction is entered by driving Chip Select (\bar{S}) Low, followed by the instruction code, and three address bytes on Serial Data input (DQ0). Any address inside the Sector (see [Table 4](#)) is a valid address for the Sector Erase (SE) instruction. Chip Select (\bar{S}) must be driven Low for the entire duration of the sequence.

The instruction sequence is shown in [Figure 24](#).

Chip Select (\bar{S}) must be driven High after the eighth bit of the last address byte has been latched in, otherwise the Sector Erase (SE) instruction is not executed. As soon as Chip Select (\bar{S}) is driven High, the self-timed Sector Erase cycle (whose duration is t_{SE}) is initiated. While the Sector Erase cycle is in progress, the Status Register may be read to check the value of the Write In Progress (WIP) bit. The Write In Progress (WIP) bit is 1 during the self-timed Sector Erase cycle, and is 0 when it is completed. At some unspecified time before the cycle is completed, the Write Enable Latch (WEL) bit is reset.

A Sector Erase (SE) instruction applied to a page which is protected by the Block Protect (BP2, BP1, BP0) bits (see [Table 3](#) and [Table 4](#)) is not executed.

Figure 24. Sector Erase (SE) instruction sequence

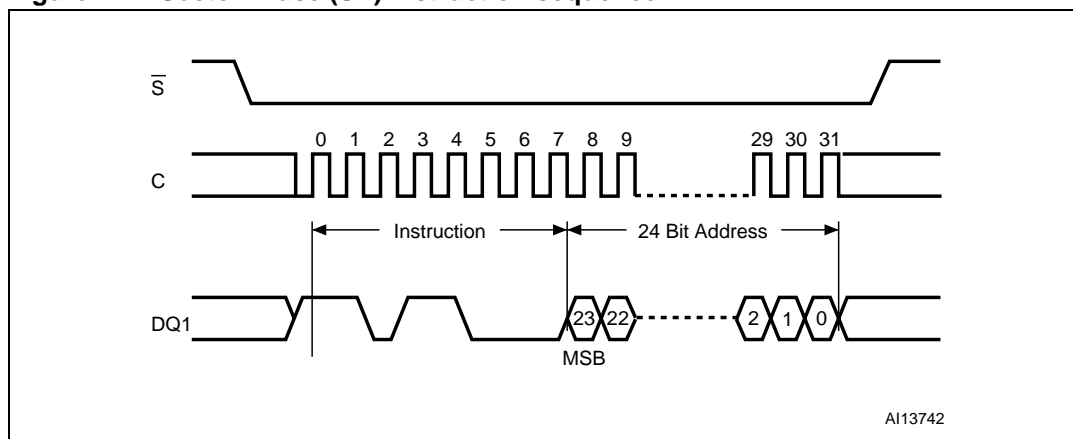

1. Address bits A23 to A22 are Don't care.

6.17 Bulk Erase (BE)

The Bulk Erase (BE) instruction sets all bits to 1 (FFh). Before it can be accepted, a Write Enable (WREN) instruction must previously have been executed. After the Write Enable (WREN) instruction has been decoded, the device sets the Write Enable Latch (WEL).

The Bulk Erase (BE) instruction is entered by driving Chip Select (\bar{S}) Low, followed by the instruction code on Serial Data input (DQ0). Chip Select (\bar{S}) must be driven Low for the entire duration of the sequence.

The instruction sequence is shown in [Figure 25](#).

Chip Select (\bar{S}) must be driven High after the eighth bit of the instruction code has been latched in, otherwise the Bulk Erase instruction is not executed. As soon as Chip Select (\bar{S}) is driven High, the self-timed Bulk Erase cycle (whose duration is t_{BE}) is initiated. While the Bulk Erase cycle is in progress, the Status Register may be read to check the value of the Write In Progress (WIP) bit. The Write In Progress (WIP) bit is 1 during the self-timed Bulk Erase cycle, and is 0 when it is completed. At some unspecified time before the cycle is completed, the Write Enable Latch (WEL) bit is reset.

The Bulk Erase (BE) instruction is executed only if all Block Protect (BP2, BP1, BP0) bits are 0. The Bulk Erase (BE) instruction is ignored if one, or more, sectors are protected.

Figure 25. Bulk Erase (BE) instruction sequence

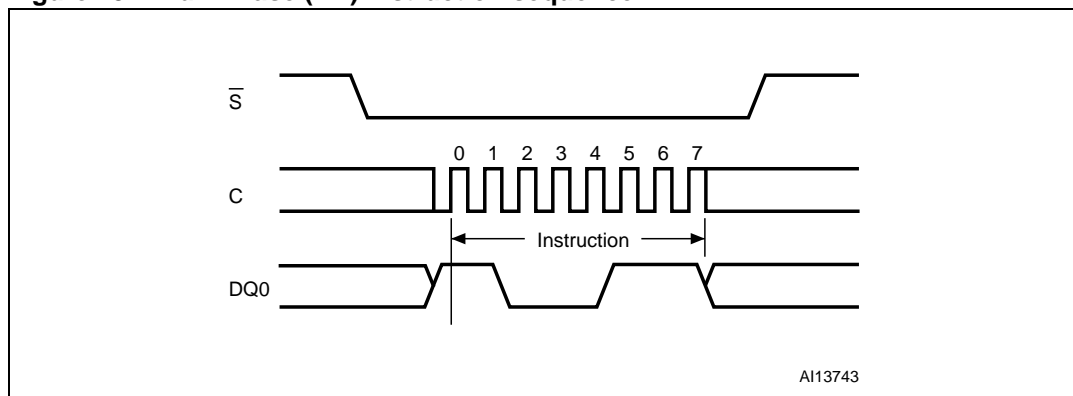

6.18 Deep Power-down (DP)

Executing the Deep Power-down (DP) instruction is the only way to put the device in the lowest consumption mode (the Deep Power-down mode). It can also be used as a software protection mechanism, while the device is not in active use, as in this mode, the device ignores all Write, Program and Erase instructions.

Driving Chip Select (\bar{S}) High deselects the device, and puts the device in the Standby Power mode (if there is no internal cycle currently in progress). But this mode is not the Deep Power-down mode. The Deep Power-down mode can only be entered by executing the Deep Power-down (DP) instruction, subsequently reducing the standby current (from I_{CC1} to I_{CC2} , as specified in [Table 17](#)).

To take the device out of Deep Power-down mode, the Release from Deep Power-down (RDP) instruction must be issued. No other instruction must be issued while the device is in Deep Power-down mode.

The Deep Power-down mode automatically stops at power-down, and the device always powers up in the Standby Power mode.

The Deep Power-down (DP) instruction is entered by driving Chip Select (\bar{S}) Low, followed by the instruction code on Serial Data input (DQ0). Chip Select (\bar{S}) must be driven Low for the entire duration of the sequence.

The instruction sequence is shown in [Figure 26](#).

Chip Select (\bar{S}) must be driven High after the eighth bit of the instruction code has been latched in, otherwise the Deep Power-down (DP) instruction is not executed. As soon as

Chip Select (\bar{S}) is driven High, it requires a delay of t_{DP} before the supply current is reduced to I_{CC2} and the Deep Power-down mode is entered.

Any Deep Power-down (DP) instruction, while an Erase, Program or Write cycle is in progress, is rejected without having any effects on the cycle that is in progress.

Figure 26. Deep Power-down (DP) instruction sequence

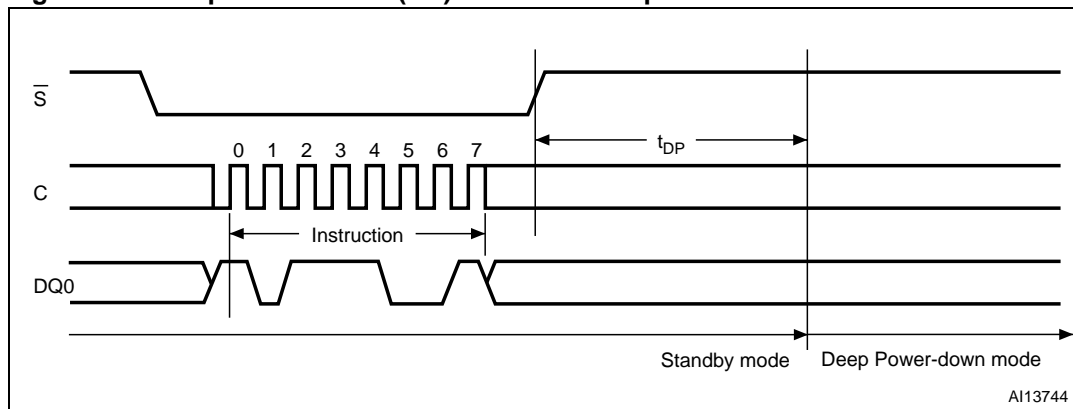

6.19 Release from Deep Power-down (RDP)

Once the device has entered the Deep Power-down mode, all instructions are ignored except the Release from Deep Power-down (RDP) instruction. Executing this instruction takes the device out of the Deep Power-down mode.

The Release from Deep Power-down (RDP) instruction is entered by driving Chip Select (\bar{S}) Low, followed by the instruction code on Serial Data input (DQ0). Chip Select (\bar{S}) must be driven Low for the entire duration of the sequence.

The instruction sequence is shown in [Figure 27](#).

The Release from Deep Power-down (RDP) instruction is terminated by driving Chip Select (\bar{S}) High. Sending additional clock cycles on Serial Clock (C), while Chip Select (\bar{S}) is driven Low, cause the instruction to be rejected, and not executed.

After Chip Select (\bar{S}) has been driven High, followed by a delay, t_{RDP} , the device is put in the Standby mode. Chip Select (\bar{S}) must remain High at least until this period is over. The device waits to be selected, so that it can receive, decode and execute instructions.

Any Release from Deep Power-down (RDP) instruction, while an Erase, Program or Write cycle is in progress, is rejected without having any effects on the cycle that is in progress.

Figure 27. Release from Deep Power-down (RDP) instruction sequence

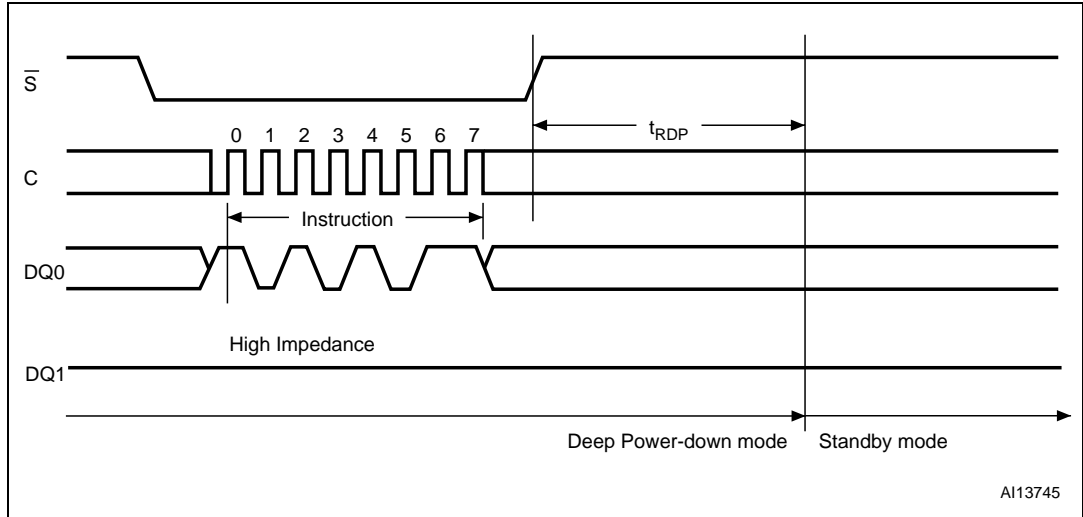

7 Power-up and power-down

At power-up and power-down, the device must not be selected (that is Chip Select (\bar{S}) must follow the voltage applied on V_{CC}) until V_{CC} reaches the correct value:

- $V_{CC}(\text{min})$ at power-up, and then for a further delay of t_{VSL}
- V_{SS} at power-down

A safe configuration is provided in [Section 3: SPI modes](#).

To avoid data corruption and inadvertent write operations during power-up, a Power On Reset (POR) circuit is included. The logic inside the device is held reset while V_{CC} is less than the Power On Reset (POR) threshold voltage, V_{WI} – all operations are disabled, and the device does not respond to any instruction.

Moreover, the device ignores all Write Enable (WREN), Page Program (PP), Dual Input Fast Program (DIFP), Program OTP (POTP), Subsector Erase (SSE), Sector Erase (SE), Bulk Erase (BE), Write Status Register (WRSR) and Write to Lock Register (WRLR) instructions until a time delay of t_{PUW} has elapsed after the moment that V_{CC} rises above the V_{WI} threshold. However, the correct operation of the device is not guaranteed if, by this time, V_{CC} is still below $V_{CC}(\text{min})$. No Write Status Register, Program or Erase instructions should be sent until the later of:

- t_{PUW} after V_{CC} has passed the V_{WI} threshold
- t_{VSL} after V_{CC} has passed the $V_{CC}(\text{min})$ level.

These values are specified in [Table 11](#).

If the time, t_{VSL} , has elapsed, after V_{CC} rises above $V_{CC}(\text{min})$, the device can be selected for READ instructions even if the t_{PUW} delay has not yet fully elapsed.

After power-up, the device is in the following state:

- The device is in the Standby Power mode (not the Deep Power-down mode).
- The Write Enable Latch (WEL) bit is reset.
- The Write In Progress (WIP) bit is reset.
- The Lock Registers are configured as: (Write Lock bit, Lock Down bit) = (0,0)

Normal precautions must be taken for supply line decoupling, to stabilize the V_{CC} supply. Each device in a system should have the V_{CC} line decoupled by a suitable capacitor close to the package pins (generally, this capacitor is of the order of 100 nF).

At power-down, when V_{CC} drops from the operating voltage, to below the Power On Reset (POR) threshold voltage, V_{WI} , all operations are disabled and the device does not respond to any instruction. (The designer needs to be aware that if power-down occurs while a Write, Program or Erase cycle is in progress, some data corruption may result.)

- V_{PPH} must be applied only when V_{CC} is stable and in the $V_{CC\text{min}}$ to $V_{CC\text{max}}$ voltage range.

Figure 28. Power-up timing

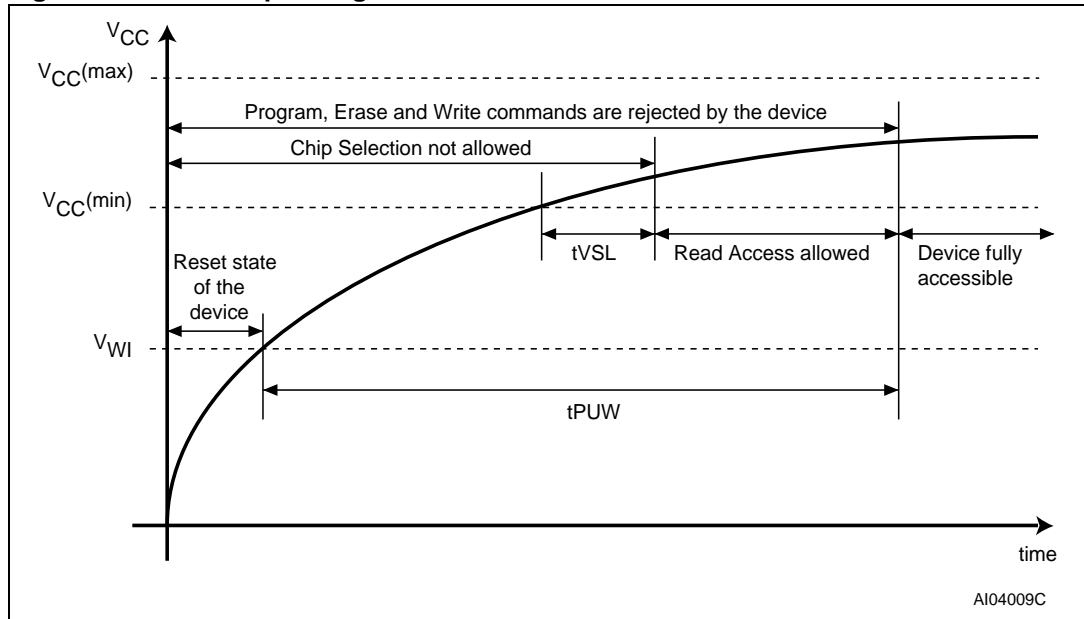

Table 11. Power-up timing and V_{WI} threshold

Symbol	Parameter	Min	Max	Unit
t _{VSL} ⁽¹⁾	V _{CC(min)} to \bar{S} low	30		μs
t _{PUW} ⁽¹⁾	Time delay to write instruction	1	10	ms
V _{WI} ⁽¹⁾	Write Inhibit voltage	1.5	2.1	V

1. These parameters are characterized only.

8 Initial delivery state

The device is delivered with the memory array erased: all bits are set to 1 (each byte contains FFh). The Status Register contains 00h (all Status Register bits are 0).

9 Maximum rating

Stressing the device outside the ratings listed in [Table 12: Absolute maximum ratings](#) may cause permanent damage to the device. These are stress ratings only, and operation of the device at these, or any other conditions outside those indicated in the operating sections of this specification, is not implied. Exposure to absolute maximum rating conditions for extended periods may affect device reliability. Refer also to the Numonyx SURE program and other relevant quality documents.

Table 12. Absolute maximum ratings

Symbol	Parameter	Min	Max	Unit
T _{STG}	Storage temperature	-65	150	°C
T _{LEAD}	Lead temperature during soldering		see ⁽¹⁾	°C
V _{IO}	Input and output voltage (with respect to ground)	-0.6	V _{CC} +0.6	V
V _{CC}	Supply voltage	-0.6	4.0	V
V _{PP}	Fast Program/Erase voltage ⁽²⁾	-0.2	10.0	V
V _{ESD}	Electrostatic discharge voltage (Human Body model) ⁽³⁾	-2000	2000	V

1. Compliant with JEDEC Std J-STD-020C (for small body, Sn-Pb or Pb assembly), and the European directive on Restrictions on Hazardous Substances (RoHS) 2002/95/EU.
2. Avoid applying V_{PPH} to the \overline{W}/VPP pin during Bulk Erase.
3. JEDEC Std JESD22-A114A (C1 = 100 pF, R1 = 1500 Ω , R2 = 500 Ω).

Table 13. Data Retention

Parameter	Condition	Min	Max	Unit
Program/Erase Cycles	Grade 3, Autograde 6, Grade 6	100000		Cycles per Sector
Data Retention	at 55°C	20		years

10 DC and AC parameters

This section summarizes the operating and measurement conditions, and the DC and AC characteristics of the device. The parameters in the DC and AC Characteristic tables that follow are derived from tests performed under the measurement conditions summarized in the relevant tables. Designers should check that the operating conditions in their circuit match the measurement conditions when relying on the quoted parameters.

Table 14. Operating conditions

Symbol	Supply Voltage(*)	Min	Typ	Max	Unit
V_{CC}	Supply Voltage	2.3		3.6	V
V_{PPH}	Supply Voltage on Vpp	8.5		9.5	V
T_A	Ambient operating temperature (device grade 6)	-40		+85	V
T_A	Ambient operating temperature (device grade 3)	-40		+125	°C

Table 15. AC measurement conditions

Symbol	Parameter	Min	Max	Unit
C_L	Load capacitance	30		pF
C_L	Input rise and fall times		5	ns
C_L	Input pulse voltages	0.2 V_{CC} to 0.8 V_{CC}		V
C_L	Input timing reference voltages	0.3 V_{CC} to 0.7 V_{CC}		V
C_L	Output timing reference voltages	$V_{CC} / 2$		V

1. Output Hi-Z is defined as the point where data out is no longer driven.

Figure 29. AC measurement I/O waveform

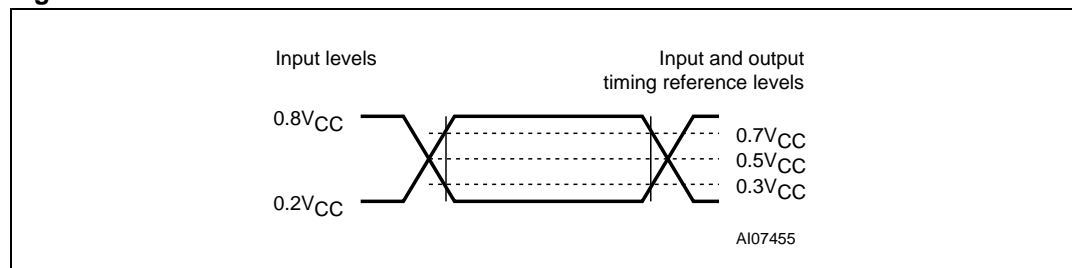

Table 16. Capacitance⁽¹⁾

Symbol	Parameter	Test condition	Min	Max	Unit
$C_{IN/OUT}$	Input/output capacitance (DQ0/DQ1)	$V_{OUT} = 0 V$		8	pF
C_{IN}	Input capacitance (other pins)	$V_{IN} = 0 V$		6	pF

1. Sampled only, not 100% tested, at $T_A=25\text{ °C}$ and a frequency of 33 MHz.

Table 17. DC characteristics

Symbol	Parameter	Test condition (in addition to those in Table 14)	Min	Max	Unit
I_{LI}	Input leakage current			± 2	μA
I_{LO}	Output leakage current			± 2	μA
I_{CC1}	Standby current	$\bar{S} = V_{CC}, V_{IN} = V_{SS} \text{ or } V_{CC}$		50	μA
I_{CC2}	Deep Power-down current	$\bar{S} = V_{CC}, V_{IN} = V_{SS} \text{ or } V_{CC}$		10	μA
I_{CC3}	Operating current (READ)	$C = 0.1V_{CC} / 0.9V_{CC}$ at 75 MHz, DQ1 = open		12	mA
		$C = 0.1V_{CC} / 0.9V_{CC}$ at 33 MHz, DQ1 = open		4	mA
	Operating current (DOFR)	$C = 0.1V_{CC} / 0.9V_{CC}$ at 75 MHz, DQ1 = open		15	mA
I_{CC4}	Operating current (PP)	$\bar{S} = V_{CC}$		15	mA
	Operating current (DIFP)	$\bar{S} = V_{CC}$		15	mA
I_{CC5}	Operating current (WRSR)	$\bar{S} = V_{CC}$		15	mA
I_{CC6}	Operating current (SE)	$\bar{S} = V_{CC}$		15	mA
I_{CC7}	Operating current (BE)	$\bar{S} = V_{CC}$		15	mA
V_{IL}	Input low voltage		-0.5	$0.3V_{CC}$	V
V_{IH}	Input high voltage		$0.7V_{CC}$	$V_{CC}+0.4$	V
V_{OL}	Output low voltage	$I_{OL} = 1.6 \text{ mA}$		0.4	V
V_{OH}	Output high voltage	$I_{OH} = -100 \mu\text{A}$	$V_{CC}-0.2$		V

Table 18. AC characteristics⁽¹⁾

Test conditions specified in Table 14 and Table 15						
Symbol	Alt.	Parameter	Min	Typ ⁽²⁾	Max	Unit
f_C	f_C	Clock frequency for the following instructions: DOFR, DIFP, FAST_READ, SSE, SE, BE, DP, WREN, WRDI, RDID, RDSR, WRSR, ROTP, PP, POTP, WRLR, RDLR, RDP	D.C.		75	MHz
f_R		Clock frequency for READ instructions	D.C.		33	MHz
$t_{CH}^{(3)}$	t_{CLH}	Clock High time	6			ns
$t_{CL}^{(2)}$	t_{CLL}	Clock Low time	6			ns
$t_{CLCH}^{(4)}$		Clock rise time ⁽⁵⁾ (peak to peak)	0.1			V/ns
$t_{CHCL}^{(4)}$		Clock fall time ⁽⁵⁾ (peak to peak)	0.1			V/ns
t_{SLCH}	t_{CSS}	\bar{S} active setup time (relative to C)	5			ns
t_{CHSL}		\bar{S} not active hold time (relative to C)	5			ns
t_{DVCH}	t_{DSU}	Data In setup time	2			ns
t_{CHDX}	t_{DH}	Data In hold time	5			ns

Table 18. AC characteristics⁽¹⁾ (continued)

Test conditions specified in Table 14 and Table 15						
Symbol	Alt.	Parameter	Min	Typ ⁽²⁾	Max	Unit
t _{CHSH}		\overline{S} active hold time (relative to C)	5			ns
t _{SHCH}		\overline{S} not active setup time (relative to C)	5			ns
t _{SHSL}	t _{CSH}	\overline{S} deselect time	80			ns
t _{SHQZ} ⁽⁴⁾	t _{DIS}	Output Disable time			8	ns
t _{CLQV}	t _v	Clock Low to Output valid under 30 pF			8	ns
		Clock Low to Output valid under 10 pF			6	ns
t _{CLQX}	t _{HO}	Output hold time	0			ns
t _{HLCH}		\overline{HOLD} setup time (relative to C)	5			ns
t _{CHHH}		\overline{HOLD} hold time (relative to C)	5			ns
t _{HHCH}		\overline{HOLD} setup time (relative to C)	5			ns
t _{CHHL}		\overline{HOLD} hold time (relative to C)	5			ns
t _{HHQX} ⁽⁴⁾	t _{LZ}	\overline{HOLD} to Output Low-Z			8	ns
t _{HLQZ} ⁽⁴⁾	t _{HZ}	\overline{HOLD} to Output High-Z			8	ns
t _{WHSL} ⁽⁶⁾		Write Protect setup time	20			ns
t _{SHWL} ⁽⁶⁾		Write Protect hold time	100			ns
t _{VPPHSL} ⁽⁷⁾		Enhanced Program supply voltage High (V _{PPH}) to Chip Select Low	200			ns
t _{DP} ⁽⁴⁾		\overline{S} High to Deep Power-down mode			3	μs
t _{RDP} ⁽⁴⁾		\overline{S} High to Standby mode			30	μs
t _W		Write Status Register cycle time		1.3	15	ms
t _{PP} ⁽⁸⁾		Page Program cycle time (256 bytes)		0.8	5	ms
		Page Program cycle time (n bytes)		int(n/8) × 0.025 ⁽⁹⁾		
		Program OTP cycle time (64 bytes)		0.2		
t _{SSE}		Subsector Erase cycle time		70	150	ms
t _{SE}		Sector Erase cycle time		0.6	3	s
t _{BE}		Bulk Erase cycle time		15	80	s

- 75 MHz operations are allowed only on the VCC range 2.7 V - 3.6 V.
- Typical values given for T_A = 25° C.
- t_{CH} + t_{CL} must be greater than or equal to 1/ f_C.
- Value guaranteed by characterization, not 100% tested in production.
- Expressed as a slew-rate.
- Only applicable as a constraint for a WRSR instruction when SRWD is set at '1'.
- V_{PPH} should be kept at a valid level until the program or erase operation has completed and its result (success or failure) is known. Avoid applying V_{PPH} to the W/VPP pin during Bulk Erase.
- When using the Page Program (PP) instruction to program consecutive bytes, optimized timings are obtained with one sequence including all the bytes versus several sequences of only a few bytes (1 ≤ n ≤ 256).
- int(A) corresponds to the upper integer part of A. For example, int(12/8) = 2, int(32/8) = 4 int(15.3) = 16.

Table 19. AC characteristics (50 MHz operation)⁽¹⁾

Test conditions specified in Table 14 and Table 15 .						
Symbol	Alt.	Parameter	Min	Typ	Max	Unit
f_C	f_C	Clock frequency ⁽¹⁾ for the following instructions: DOFR, DIFP, FAST_READ, PP, SE, BE, DP, RES, WREN, WRDI, RDID, RDSR, WRSR	D.C.		50	MHz
f_R		Clock frequency for read instructions	D.C.		25	MHz
$t_{CH}^{(2)}$	t_{CLH}	Clock high time	9			ns
$t_{CL}^{(2)}$	t_{CLL}	Clock low time	9			ns
$t_{CLCH}^{(3)}$		Clock rise time ⁽⁴⁾ (peak to peak)	0.1			V/ns
$t_{CHCL}^{(3)}$		Clock fall time ⁽⁴⁾ (peak to peak)	0.1			V/ns
t_{SLCH}	t_{CSS}	\overline{S} active setup time (relative to C)	5			ns
t_{CHSL}		\overline{S} not active hold time (relative to C)	5			ns
t_{DVCH}	t_{DSU}	Data in setup time	2			ns
t_{CHDX}	t_{DH}	Data in hold time	5			ns
t_{CHSH}		\overline{S} active hold time (relative to C)	5			ns
t_{SHCH}		\overline{S} not active setup time (relative to C)	5			ns
t_{SHSL}	t_{CSH}	\overline{S} deselect time	100			ns
$t_{SHQZ}^{(3)}$	t_{DIS}	Output disable time			8	ns
t_{CLQV}	t_V	Clock Low to Output Valid			8	ns
t_{CLQX}	t_{HO}	Output hold time	0			ns
t_{HLCH}		\overline{HOLD} setup time (relative to C)	5			ns
t_{CHHH}		\overline{HOLD} hold time (relative to C)	5			ns
t_{HHCH}		\overline{HOLD} setup time (relative to C)	5			ns
t_{CHHL}		\overline{HOLD} hold time (relative to C)	5			ns
$t_{HHQX}^{(3)}$	t_{LZ}	\overline{HOLD} to Output Low-Z			8	ns
$t_{HLQZ}^{(3)}$	t_{HZ}	\overline{HOLD} to Output High-Z			8	ns
$t_{WHSL}^{(5)}$		Write protect setup time	20			ns
$t_{SHWL}^{(5)}$		Write protect hold time	100			ns
$t_{DP}^{(3)}$		\overline{S} High to deep power-down mode			3	μ s
$t_{RDP}^{(3)}$		\overline{S} High to standby mode			30	μ s

- 50 MHz operation is also available on VCC range 2.3 to 2.7 V.
- $t_{CH} + t_{CL}$ must be greater than or equal to $1/f_C$.
- Value guaranteed by characterization, not 100% tested in production.
- Expressed as a slew-rate.
- Only applicable as a constraint for a WRSR instruction when SRWD is set to '1'.

Figure 30. Serial input timing

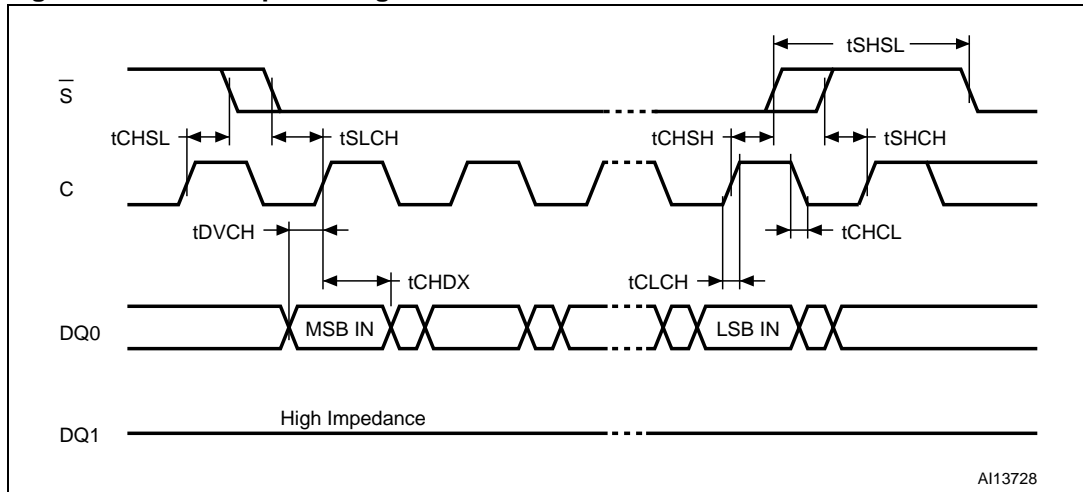

AI13728

Figure 31. Write Protect Setup and Hold timing during WRSR when SRWD=1

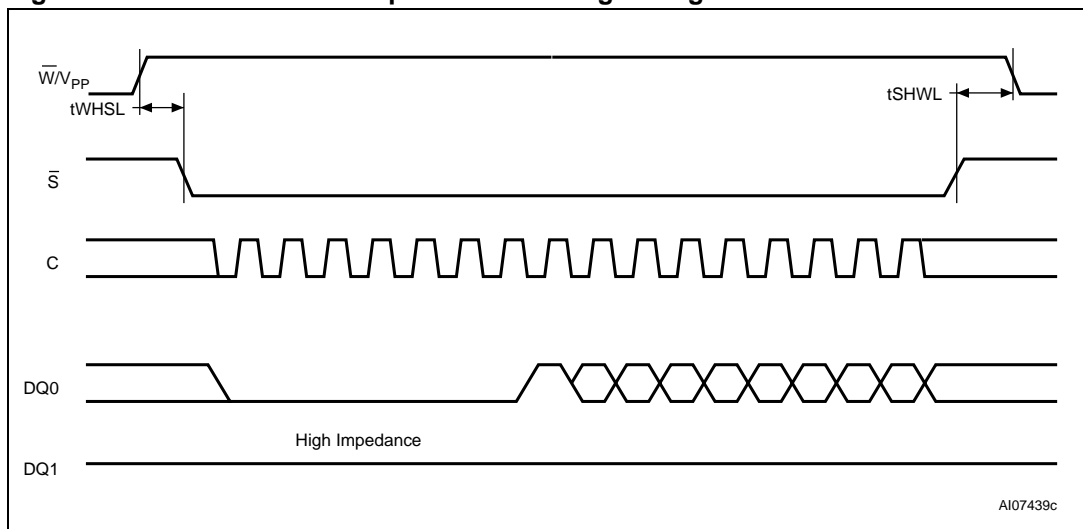

AI07439c

Figure 32. Hold timing

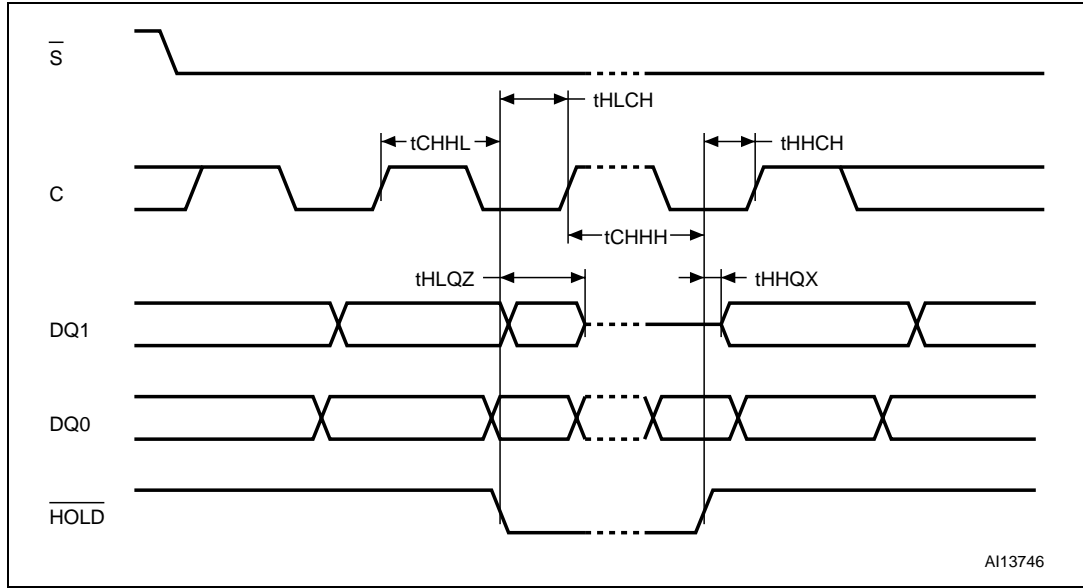

Figure 33. Output timing

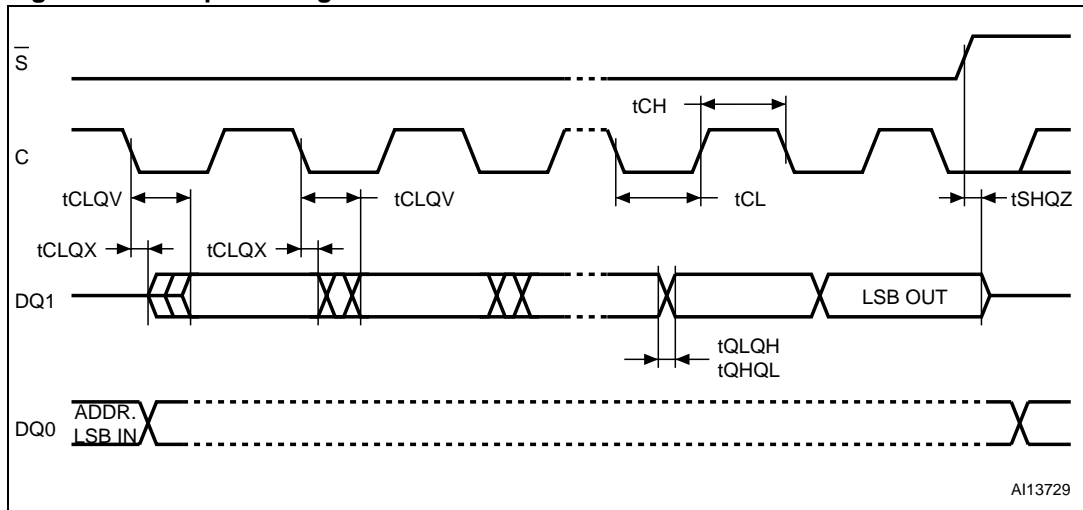
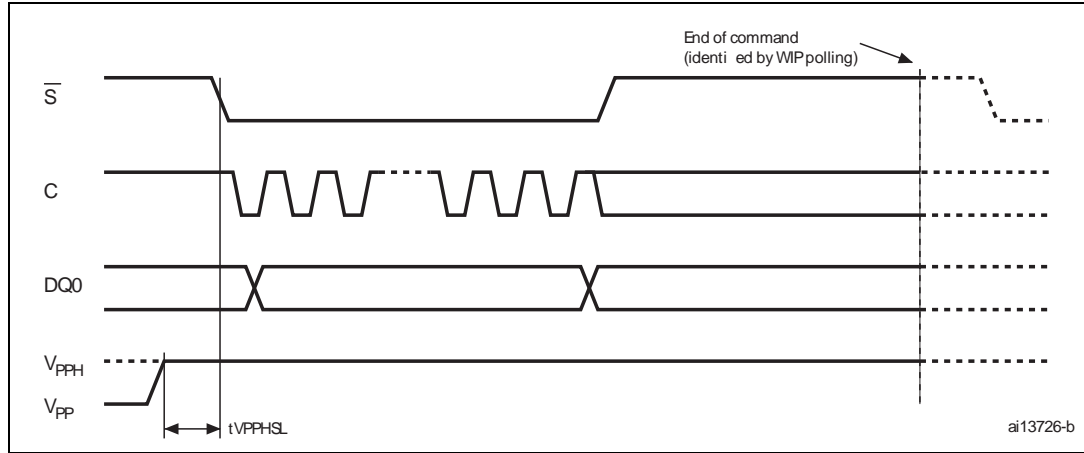

Figure 34. V_{PPH} timing



ai13726-b

11 Package mechanical

In order to meet environmental requirements, Numonyx offers these devices in RoHS packages. These packages have a Lead-free second level interconnect. The category of second level interconnect is marked on the package and on the inner box label, in compliance with JEDEC Standard JESD97. The maximum ratings related to soldering conditions are also marked on the inner box label.

Figure 35. VFQFPN8 (MLP8) 8-lead very thin fine pitch dual flat package no lead, 6 × 5 mm, package outline

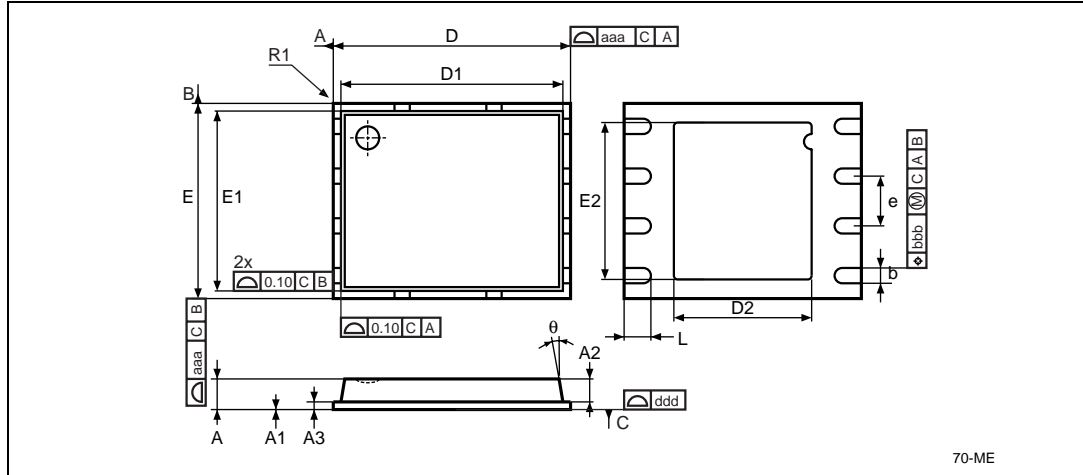

1. Drawing is not to scale.

Table 20. VFQFPN8 (MLP8) 8-lead very thin fine pitch dual flat package no lead, 6 × 5 mm, package mechanical data

Symbol	Millimeters			Inches		
	Typ	Min	Max	Typ	Min	Max
A	0.85	0.80	1.00	0.0335	0.0315	0.0394
A1		0.00	0.05		0.0000	0.0020
A2	0.65			0.0256		
A3	0.20			0.0079		
b	0.40	0.35	0.48	0.0157	0.0138	0.0189
D	6.00			0.2362		
D1	5.75			0.2264		
D2	3.40	3.20	3.60	0.1339	0.1260	0.1417
E	5.00			0.1969		
E1	4.75			0.1870		
E2	4.00	3.80	4.30	0.1575	0.1496	0.1693
e	1.27	–	–	0.0500	–	–
R1	0.10	0.00		0.0039	0.0000	

Table 20. VFQFPN8 (MLP8) 8-lead very thin fine pitch dual flat package no lead, 6 × 5 mm, package mechanical data

Symbol	Millimeters			Inches		
	Typ	Min	Max	Typ	Min	Max
L	0.60	0.50	0.75	0.0236	0.0197	0.0295
Θ			12°			12°
aaa			0.15			0.0059
bbb			0.10			0.0039
ddd			0.05			0.0020

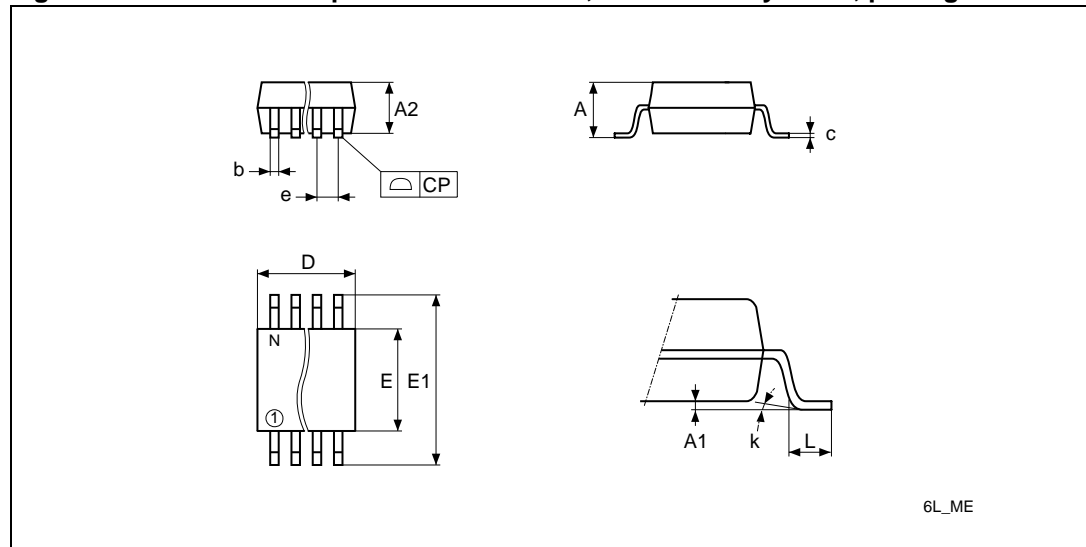
Figure 36. SO8W 8-lead plastic small outline, 208 mils body width, package outline

1. Drawing is not to scale.

Table 21. SO8W 8-lead plastic small outline, 208 mils body width, package mechanical data

Symbol	Millimeters			Inches		
	Typ	Min	Max	Typ	Min	Max
A			2.50			0.098
A1		0.00	0.25		0.000	0.010
A2		1.51	2.00		0.059	0.079
b	0.40	0.35	0.51	0.016	0.014	0.020
c	0.20	0.10	0.35	0.008	0.004	0.014
CP			0.10			0.004
D			6.05			0.238
E		5.02	6.22		0.198	0.245
E1		7.62	8.89		0.300	0.350

Table 21. SO8W 8-lead plastic small outline, 208 mils body width, package mechanical data

Symbol	Millimeters			Inches		
	Typ	Min	Max	Typ	Min	Max
e	1.27	–	–	0.050	–	–
k		0°	10°		0°	10°
L		0.50	0.80		0.020	0.031
N		8			8	

Figure 37. SO8N – 8 lead plastic small outline, 150 mils body width, package outline

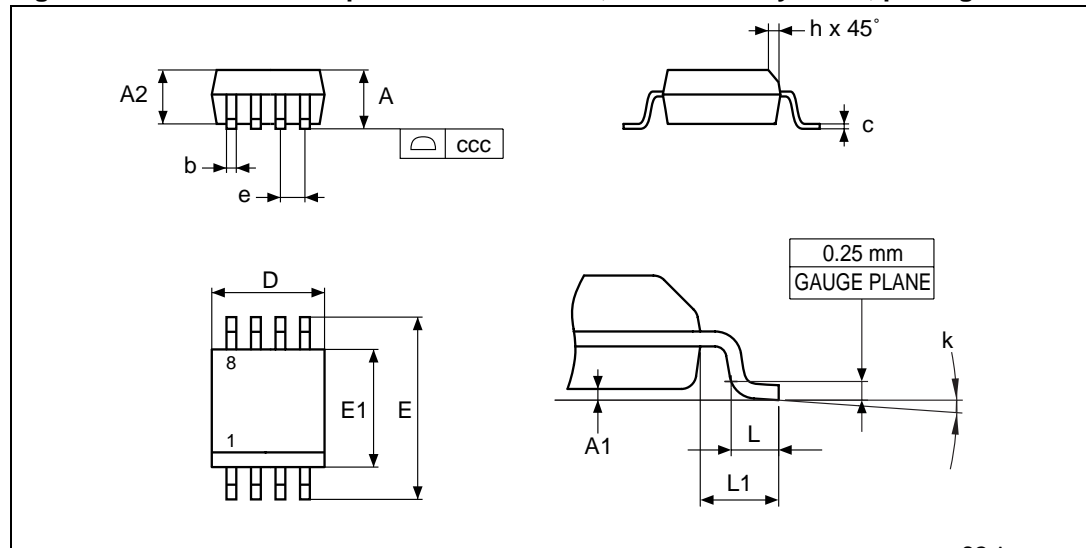

1. Drawing is not to scale.

Table 22. SO8N – 8 lead plastic small outline, 150 mils body width, package mechanical data

Symbol	millimeters			inches		
	Typ	Min	Max	Typ	Min	Max
A			1.75			0.069
A1		0.10	0.25		0.004	0.010
A2		1.25			0.049	
b		0.28	0.48		0.011	0.019
c		0.17	0.23		0.007	0.009
ccc			0.10			0.004
D	4.90	4.80	5.00	0.193	0.189	0.197
E	6.00	5.80	6.20	0.236	0.228	0.244
E1	3.90	3.80	4.00	0.154	0.150	0.157
e	1.27	–	–	0.050	–	–

Table 22. SO8N – 8 lead plastic small outline, 150 mils body width, package mechanical data

Symbol	millimeters			inches		
	Typ	Min	Max	Typ	Min	Max
h		0.25	0.50		0.010	0.020
k		0°	8°		0°	8°
L		0.40	1.27		0.016	0.050
L1	1.04			0.041		

Figure 38. TBGA, 6x8 mm, 24 ball package outline

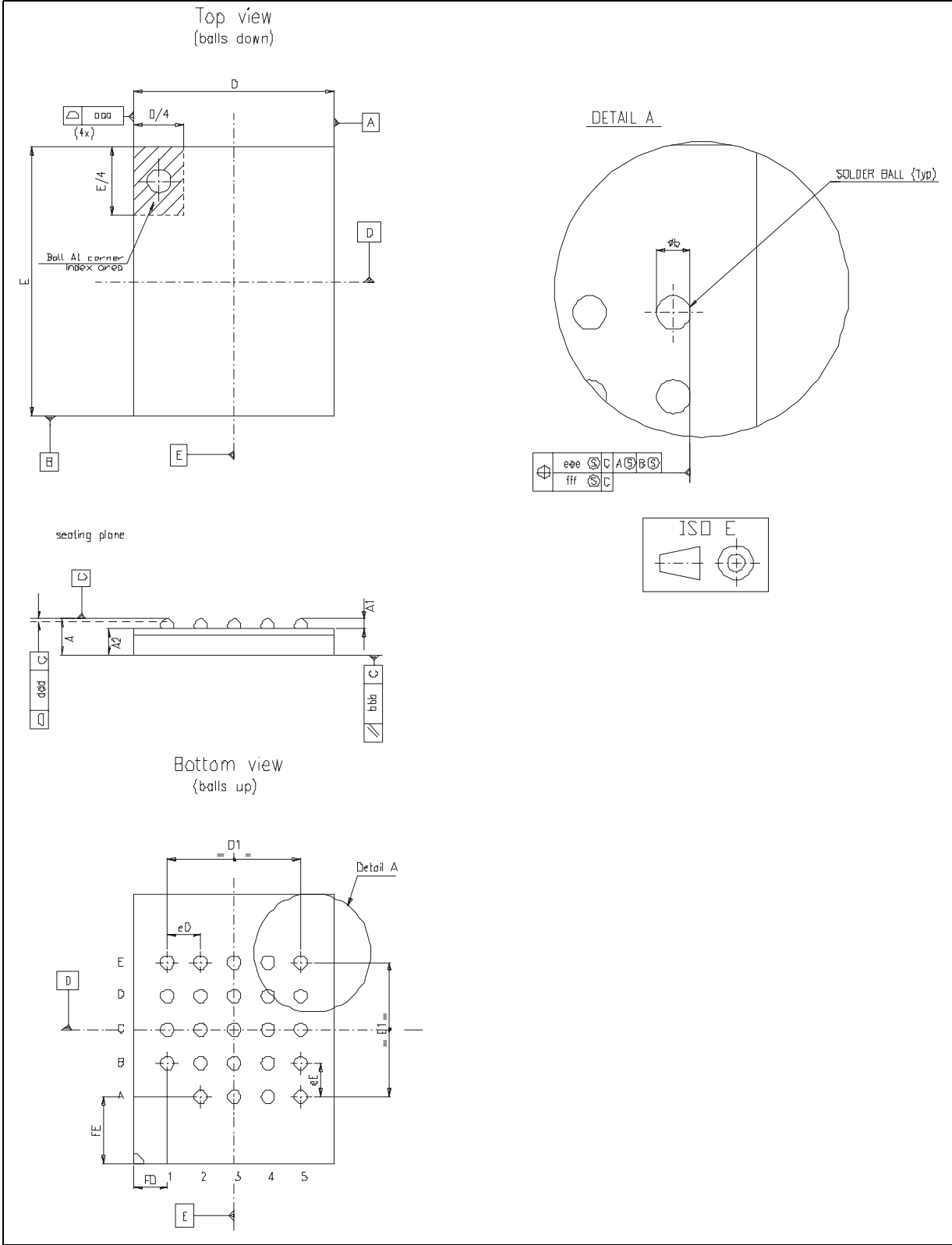

Table 23. TBGA 6x8 mm 24-ball package dimensions

	MIN	NOM	MAX
A			1.20
A1	0.20		
A2		0.79	
Øb	0.35	0.40	0.45
D	5.90	6.00	6.10
D1		4.00	
E	7.90	8.00	8.10
E1		4.00	
eD		1.00	
eE		1.00	
FD		1.00	
FE		2.00	
MD	5		
ME	5		
n	24 balls		
aaa			0.15
bbb			0.10
ddd			0.10
eee			0.15
fff			0.08
Control unit: mm			

12 Ordering information

Table 24. Ordering information scheme

Example:	M25PX16	-	V	MW	6	T	P	B	A
Device type	<div style="border: 1px solid black; width: 100%; height: 100%;"></div>								
M25PX = serial Flash memory, 4-Kbyte and 64-Kbyte erasable sectors, dual input/output									
Device function									
16 = 16 Mbit (2 Mbit x 8)									
Security features⁽¹⁾									
- = no extra security									
SO = OTP configurable + CFD programmed with UID									
ST = OTP configurable + protection at power_up + CFD programmed with UID									
S- = CFD programmed with UID									
Operating voltage									
V = V _{CC} = 2.3 V to 3.6 V (Automotive part available only in 2.7 - 3.6 V)									
Package	<div style="border: 1px solid black; width: 100%; height: 100%;"></div>								
MW = SO8W (208 mils width)									
MN = SO8N (150 mils width)									
MP = VFQFPN 6 x 5 mm (MLP8)									
ZM = TBGA24 6 x 8 mm									
ME = VDFPN8 8 x 6 mm (MLP8)									
Device grade									
6 = Industrial temperature range, -40 to 85 °C. Device tested with standard test flow]									
3 ⁽²⁾ = Automotive grade 3 temperature range, -40 to 125 °C. Device tested with High Reliability Certified Flow									
Option									
blank = Standard packing (Tube for SO8N, SO8W, SO16, and PDIP packages; Tray for MLP and BGA packages)									
T = Tape and reel packing									
Plating technology	<div style="border: 1px solid black; width: 100%; height: 100%;"></div>								
P or G = RoHS compliant									
Lithography									
B = 110 nm, Fab.2 Diffusion Plant (Automotive Only)									
blank = 110 nm									
Automotive grade									
A ⁽²⁾ = Automotive grade 6 temperature range, -40 to 85 °C Device tested with High Reliability Certified Flow									
blank = standard device temperature range, -40 to 85 °C									

1. Secure options are available upon customer request.
 2. Numonyx strongly recommends the use of the Automotive Grade devices (AutoGrade 6 and Grade 3) for use in an automotive environment. The High Reliability Certified Flow (HRCF) is described in the quality note QNEE9801.

Note: For a list of available options (speed, package, etc.) or for further information on any aspect of this device, please contact your nearest Numonyx Sales Office.

13 Revision history

Table 25. Document revision history

Date	Revision	Changes
12-Aug-2008	1	Initial release.
27-Aug-2008	2	Corrected bulk erase specifications on the cover page; Changed V _{wi} from 2.5 V to 2.1 V in Table 11: Power-up timing and VWI threshold on page 46 due to 2.3 V operations; Corrected the programmable bit range in Table 21: How to permanently lock the 64 OTP bytes on page 39 .
24-Sept-2008	3	Added the following information regarding Bulk Erase: Avoid applying V _{PPH} to the W/VPP pin during Bulk Erase.
04-February-2009	4	Added the TBGA package and accompanying informaiton.
16-February-2009	5	Added Notes to the TBGA package.
17-March-2009	6	Made the following changes: – Added “Automotive certified parts” information to cover page, and to Ordering Information; – Added Data Retention table; – Revised the Operating Condition table.
22-June-2009	7	Corrected data in Table 14.: Operating conditions . Revised and clarified ordering information.
10-March-2010	8	Removed SO16W package information from Ordering Information table.

Please Read Carefully:

INFORMATION IN THIS DOCUMENT IS PROVIDED IN CONNECTION WITH NUMONYX™ PRODUCTS. NO LICENSE, EXPRESS OR IMPLIED, BY ESTOPPEL OR OTHERWISE, TO ANY INTELLECTUAL PROPERTY RIGHTS IS GRANTED BY THIS DOCUMENT. EXCEPT AS PROVIDED IN NUMONYX'S TERMS AND CONDITIONS OF SALE FOR SUCH PRODUCTS, NUMONYX ASSUMES NO LIABILITY WHATSOEVER, AND NUMONYX DISCLAIMS ANY EXPRESS OR IMPLIED WARRANTY, RELATING TO SALE AND/OR USE OF NUMONYX PRODUCTS INCLUDING LIABILITY OR WARRANTIES RELATING TO FITNESS FOR A PARTICULAR PURPOSE, MERCHANTABILITY, OR INFRINGEMENT OF ANY PATENT, COPYRIGHT OR OTHER INTELLECTUAL PROPERTY RIGHT.

Numonyx products are not intended for use in medical, life saving, life sustaining, critical control or safety systems, or in nuclear facility applications.

Numonyx may make changes to specifications and product descriptions at any time, without notice.

Numonyx, B.V. may have patents or pending patent applications, trademarks, copyrights, or other intellectual property rights that relate to the presented subject matter. The furnishing of documents and other materials and information does not provide any license, express or implied, by estoppel or otherwise, to any such patents, trademarks, copyrights, or other intellectual property rights.

Designers must not rely on the absence or characteristics of any features or instructions marked "reserved" or "undefined." Numonyx reserves these for future definition and shall have no responsibility whatsoever for conflicts or incompatibilities arising from future changes to them.

Contact your local Numonyx sales office or your distributor to obtain the latest specifications and before placing your product order.

Copies of documents which have an order number and are referenced in this document, or other Numonyx literature may be obtained by visiting Numonyx's website at <http://www.numonyx.com>.

Numonyx StrataFlash is a trademark or registered trademark of Numonyx or its subsidiaries in the United States and other countries.

*Other names and brands may be claimed as the property of others.

Copyright © 2010, Numonyx, B.V., All Rights Reserved.