

DIGITAL I²C TEMPERATURE SENSOR

Features

- High Accuracy Temperature Sensor
 - Si7057: ±0.35 °C (max), 0 to 70 °C
 - Si7058: ±0.5 °C (max), 0 to 70 °C
 - Si7059: ±1.0 °C (max), 0 to 70 °C
- -40 to +125 °C operating range
- Low Voltage Operation (1.8 V)
- 14-bit resolution
- Low Power Consumption
 - 50 nA, standby current
- Factory-calibrated
- I²C Interface
- Pin-selectable I²C addresses
- 2x2 mm QFN package
- Excellent long term stability

Applications

- Mobile smartphones and tablets
- Consumer electronics
- HVAC/R
- White goods
- Asset and goods tracking
- Thermostats
- Micro-environments/data centers
- Indoor weather stations

Description

The Si7057/8/9 I²C Temperature Sensors are monolithic CMOS ICs that integrate temperature sensor elements, an analog-to-digital converter, signal processing, calibration data, and an I²C interface.

The temperature sensors are factory-calibrated and the calibration data is stored in the on-chip non-volatile memory. This ensures that the sensors are fully interchangeable, with no calibration or software changes required.

The Si7057/8/9 devices are available in a 2x2 mm DFN package and are reflow solderable. The Si7057/8/9 sensors offer an accurate, low-power, factory-calibrated digital solution ideal for measuring temperature in applications ranging from HVAC/R and asset tracking to industrial and consumer platforms.

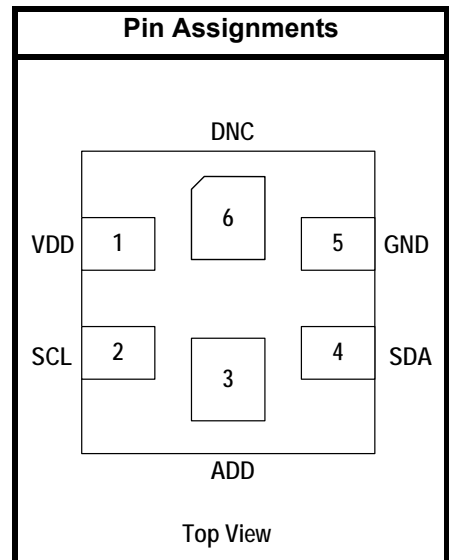

Patent Protected. Patents pending

Si7057/8/9-A10

Functional Block Diagram

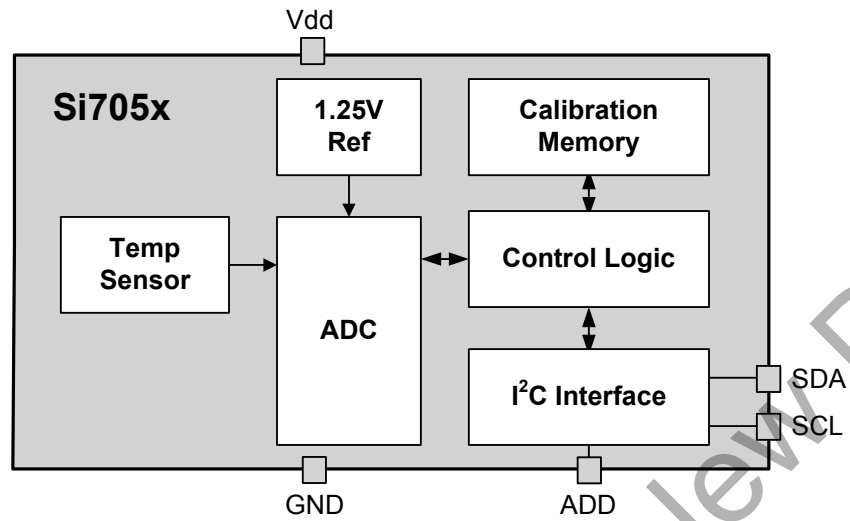

TABLE OF CONTENTS

Section	Page
1. Electrical Specifications	4
2. Typical Application Circuit	9
3. Bill of Materials	10
4. Functional Description	11
5. I2C Interface	12
5.1. Issuing a Measurement Command	13
5.2. Measuring Temperature	14
5.3. Firmware Revision	14
5.4. Electronic Serial Number	15
6. Pin Descriptions: Si7057/8/9 (Top View)	16
7. Ordering Guide	17
8. Package Outline	18
8.1. Package Outline: 2x2 6-pin QFN	18
9. PCB Land Pattern and Solder Mask Design	19
10. Top Marking	20
10.1. Si7057/8/9 Top Marking	20
10.2. Top Marking Explanation	20
11. Additional Reference Resources	21
Document Change List	22

Si7057/8/9-A10

1. Electrical Specifications

Unless otherwise specified, all min/max specifications apply over the recommended operating conditions.

Table 1. Recommended Operating Conditions

Parameter	Symbol	Test Condition	Min	Typ	Max	Unit
Power Supply	V _{DD}		1.67	—	1.98	V
Operating Temperature	T _A		-40	—	+125	°C

Table 2. General Specifications

1.67 ≤ V_{DD} ≤ 1.98 V; T_A = -40 to +125 °C unless otherwise noted.

Parameter	Symbol	Test Condition	Min	Typ	Max	Unit
Input Voltage High	V _{IH}	ADD, SCL, SDA pins	0.7xV _{DD}	—	—	V
Input Voltage Low	V _{IL}	ADD, SCL, SDA pins	—	—	0.3xV _{DD}	V
Input Voltage Range	V _{IN}	SCL, SDA pins with respect to GND	0.0	—	V _{DD} +2	V
		ADD pin with respect to GND	0.0	—	V _{DD} +0.3	V
Input Leakage	I _{IL}	ADD, SCL, SDA pins	—	—	1	μA
Output Voltage Low	V _{OL}	SDA pin; I _{OL} = 1.5 mA	—	—	0.4	V
Current Consumption	I _{DD}	Normal Mode, Temperature conversion in progress, first step ¹	—	245	288	μA
		Normal Mode, Temperature conversion in progress, second step ¹	—	106	145	μA
		Standby, -40 to +85 °C ²	—	0.05	0.56	μA
		Standby, -40 to +125 °C ²	—	0.05	5.2	μA
		Peak I _{DD} during powerup ³	—	4	5.1	mA
		Peak I _{DD} during I ² C operations ⁴	—	3.5	4	mA
		After writing to user registers ⁵	—	11.6	17	μA

Notes:

- Total conversion time is first-step time plus second-step time.
- No conversion or I²C transaction in progress. Typical values measured at 25 °C.
- Occurs once during powerup. Duration is <5 msec.
- Occurs during I²C commands for Reset, Read/Write User Registers, Read EID, and Read Firmware Version. Duration is <100 μs when I²C clock speed is >100 kHz (>200 kHz for 2-byte commands).
- I_{DD} after a user register write. Initiating any other subsequent I²C transaction on the same bus (such as a user register read, starting an RH measurement, or traffic directed at other I²C devices) will transition the device to standby mode.

Table 2. General Specifications (Continued)1.67 ≤ V_{DD} ≤ 1.98 V; T_A = -40 to +125 °C unless otherwise noted.

Parameter	Symbol	Test Condition	Min	Typ	Max	Unit
Conversion Time ¹	t _{CONV}	Normal Mode, Temperature conversion first step		3.7	6	ms
		Fast Mode, Temperature conversion first step		0.9	1.5	ms
		Normal or Fast Mode, Temperature conversion second step		2.5	4.0	ms
Powerup Time	t _{PU}	From VDD ≥ 1.67 V to ready for a conversion, 25 °C	—	10	15	ms
		From VDD ≥ 1.67 V to ready for a conversion, full temperature range	—	—	50	ms
		After issuing a software reset command	—	1.2	2.0	ms
Notes:						
1. Total conversion time is first-step time plus second-step time.						
2. No conversion or I ² C transaction in progress. Typical values measured at 25 °C.						
3. Occurs once during powerup. Duration is <5 msec.						
4. Occurs during I ² C commands for Reset, Read/Write User Registers, Read EID, and Read Firmware Version. Duration is <100 μs when I ² C clock speed is >100 kHz (>200 kHz for 2-byte commands).						
5. IDD after a user register write. Initiating any other subsequent I ² C transaction on the same bus (such as a user register read, starting an RH measurement, or traffic directed at other I ² C devices) will transition the device to standby mode.						

Si7057/8/9-A10

Table 3. I²C Interface Specifications¹

1.67 ≤ V_{DD} ≤ 1.98 V; T_A = -40 to +125 °C unless otherwise noted.

Parameter	Symbol	Test Condition	Min	Typ	Max	Unit
Hysteresis	V _{HYS}	High-to-low versus low-to-high transition	0.05 x V _{DD}	—	—	V
SCLK Frequency ²	f _{SCL}		—	—	400	kHz
SCL High Time	t _{SKH}		0.6	—	—	μs
SCL Low Time	t _{SKL}		1.3	—	—	μs
Start Hold Time	t _{STH}		0.6	—	—	μs
Start Setup Time	t _{STS}		0.6	—	—	μs
Stop Setup Time	t _{SPS}		0.6	—	—	μs
Bus Free Time	t _{BUF}	Between Stop and Start	1.3	—	—	μs
SDA Setup Time	t _{DS}		100	—	—	ns
SDA Hold Time	t _{DH}		100	—	—	ns
SDA Valid Time	t _{VD;DAT}	From SCL low to data valid	—	—	0.9	μs
SDA Acknowledge Valid Time	t _{VD;ACK}	From SCL low to data valid	—	—	0.9	μs
Suppressed Pulse Width ³	t _{SP}		50	—	—	ns

Notes:

1. All values are referenced to V_{IL} and/or V_{IH}.
2. Depending on the conversion command, the Si7057/8/9 may hold the master during the conversion (clock stretch). At above 300 kHz SCL, the Si7057/8/9 may hold the master briefly for user register and device ID transactions. At the highest I²C speed of 400 kHz the stretching will be <50 μs.
3. Pulses up to and including 50 ns will be suppressed.

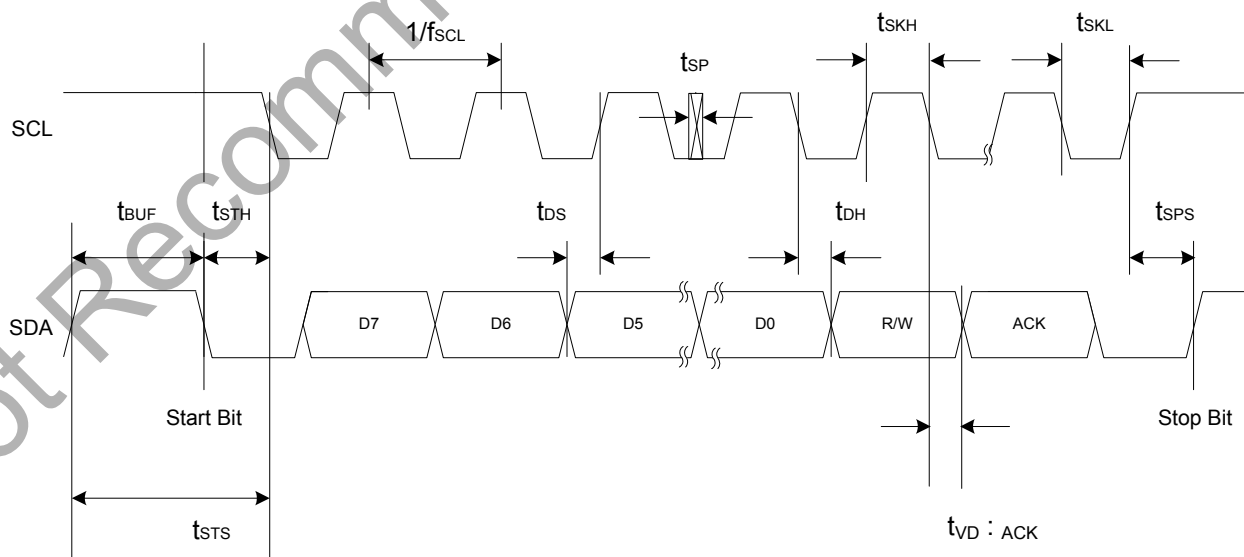

Figure 1. I²C Interface Timing Diagram

Table 4. Temperature Sensor1.67 ≤ V_{DD} ≤ 1.98 V; T_A = -40 to +125 °C unless otherwise noted.

Parameter	Symbol	Test Condition	Min	Typ	Max	Unit
Operating Range			-40	—	+125	°C
Accuracy ¹		t _A = 30 °C, Si7057	—	0.2	0.35	°C
		t _A = 30 °C, Si7058	—	0.25	0.5	°C
		t _A = 30 °C, Si7059	—	0.5	1.0	°C
		-40 ≤ t _A ≤ 125 °C	—	Figure 2	Figure 3	°C
Repeatability/Noise ²		Normal	—	0.03	—	°C RMS
		Fast	—	0.09	—	°C RMS
Response Time ³	T _{63%}	Unmounted device	—	0.7	—	s
		Si7057/8/9-EB	—	5.1	—	s
Long Term Stability			—	≤ 0.01	—	°C/Yr

Notes:

1. Normal conversion time.
2. 3-sigma measurement deviation.
3. Time to reach 63% of final value in response to a step change in temperature. Actual response time will vary dependent on system thermal mass and air-flow.

**Figure 2. Typical Temperature Accuracy****Figure 3. Max Temperature Accuracy**

Table 5. Thermal Characteristics

Parameter	Symbol	Test Condition	QFN-6	Unit
Junction to Air Thermal Resistance	θ_{JA}	JEDEC 2-Layer Board, No Airflow	173	°C/W
Junction to Air Thermal Resistance	θ_{JA}	JEDEC 2-Layer Board, 1 m/s Airflow	153	°C/W
Junction to Air Thermal Resistance	θ_{JA}	JEDEC 2-Layer Board, 2 m/s Airflow	146	°C/W
Junction to Case Thermal Resistance	θ_{JC}	JEDEC 2-Layer Board	84	°C/W
Junction to Board Thermal Resistance	θ_{JB}	JEDEC 2-Layer Board	114	°C/W

Table 6. Absolute Maximum Ratings^{1,2}

Parameter	Symbol	Test Condition	Min	Typ	Max	Unit
Ambient temperature under bias			-55	—	125	°C
Storage Temperature			-65	—	150	°C
Voltage on I/O pins			-0.3	—	VDD+2.0 V	V
Voltage on VDD with Respect to GND			-0.3	—	2.3	V
ESD Tolerance		HBM			2	kV
		CDM			1.25	kV
		MM			250	V

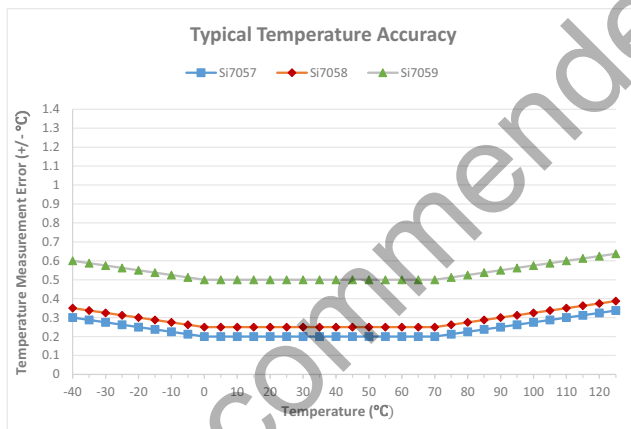
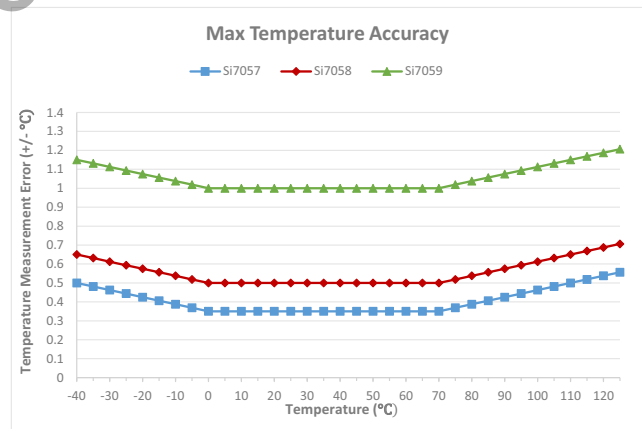
Notes:

1. Absolute maximum ratings are stress ratings only, operation at or beyond these conditions is not implied and may shorten the life of the device or alter its performance.
2. Special handling considerations apply; see application note, "AN607: Si70xx Humidity and Temperature Sensor Designer's Guide".

2. Typical Application Circuit

The primary function of the Si7057/8/9 is to measure temperature. Figure 4 demonstrates the typical application circuit to achieve this function. Pin 6 may be left unconnected or tied to VDD.

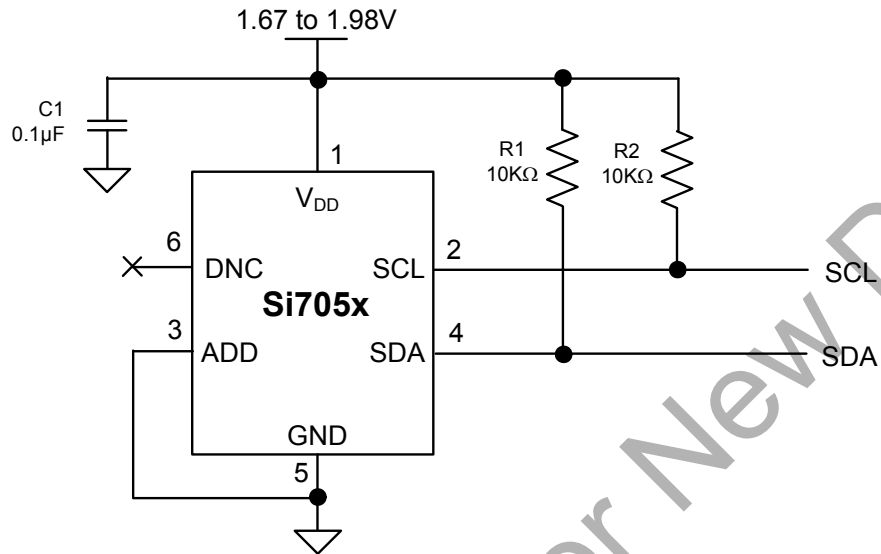

Figure 4. Typical Application Circuit for Temperature Measurement

Si7057/8/9-A10

3. Bill of Materials

Table 7. Typical Application Circuit BOM for Temperature Measurement

Reference	Description	Mfr Part Number	Manufacturer
R1	Resistor, 10 k Ω , \pm 5%, 1/16W, 0402	CR0402-16W-103JT	Venkel
R2	Resistor, 10 k Ω , \pm 5%, 1/16W, 0402	CR0402-16W-103JT	Venkel
C1	Capacitor, 0.1 μ F, 6.3 V, X7R, 0402	C0402X7R6R3-104MNP	Venkel
U1	IC, Digital Temperature Sensor	Si7057/8/9-A10-IM	Silicon Labs

4. Functional Description

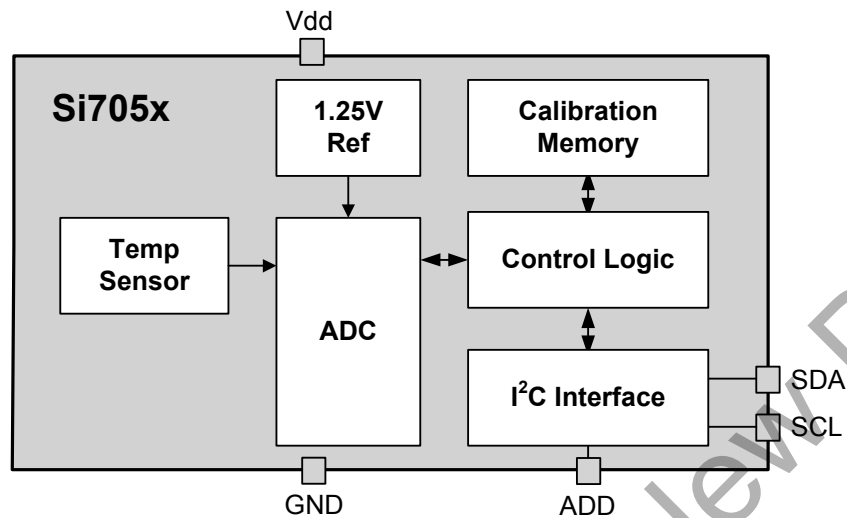

Figure 5. Si7057/8/9 Block Diagram

The Si7057/8/9 are digital temperature sensors that integrate a sensor element, an analog-to-digital converter, signal processing, calibration, polynomial non-linearity correction, and an I²C interface all in a single chip. The Si7057/8/9 are factory-calibrated with the calibration data stored in on-chip non-volatile memory. This ensures that the sensor is fully interchangeable, with no recalibration or changes to software required. The Si7057/8/9 offer low power, high accuracy, calibrated and stable solution ideal for a wide range of temperature applications including medical and instrumentation, high-reliability automotive and industrial systems, and cost-sensitive consumer electronics.

5. I²C Interface

The Si7057/8/9 communicates with the Host controller over a digital I²C interface. The 7-bit base slave address is pin-selectable to be either 0x71 (ADD pin low) or 0x72 (ADD pin high).

Table 8. I²C Slave Address Byte

Bit	A6	A5	A4	A3	A2	A1	A0	R/W
Value when ADD Low	1	1	1	0	0	0	1	1/0
Value when ADD High	1	1	1	0	0	1	0	1/0

Master I²C devices communicate with the Si7057/8/9 using a command structure. The commands are listed in the I²C command table. Commands other than those documented below are undefined and should not be sent to the device.

Table 9. I²C Command Table

Command	Hold/No Hold Mode	Hex Code
Read Electronic ID: Two Separate IDs with checksum	—	0xFA 0x0F
Read Electronic ID: Two Separate IDs with checksum	—	0xFC 0xC9
Soft Reset	—	0xFE
Temperature Measurement: Normal Mode	Hold Mode	0x7C 0xA2
Temperature Measurement: Normal Mode	No Hold Mode	0x78 0x66
Temperature Measurement: Fast Mode	Hold Mode	0x64 0x58
Temperature Measurement: Fast Mode	No Hold Mode	0x60 0x9C
Query Device	Device will ACK command, No Functional Effect or response	0x80 0x5D
Query Device	Response 0x00 0x47 0x2B	0xEF 0xC8
Read Firmware Revision	—	0x84 0xF1

5.1. Issuing a Measurement Command

The measurement commands instruct the Si7057/8/9 to perform temperature measurements. The procedure to issue any one of these commands is identical. While the measurement is in progress, the option of either clock stretching (Hold Master Mode) or Not Acknowledging read requests (No Hold Master Mode) is available to indicate to the master that the measurement is in progress; the chosen command code determines which mode is used. A checksum byte is returned from the slave for use in checking for transmission errors. The checksum byte will follow the least significant measurement byte. The checksum byte is calculated using a CRC generator polynomial of $x^8 + x^5 + x^4 + 1$, with an initialization of 0xFC.

Table 10. I²C Bit Descriptions

Name	Symbol	Description
START	S	SDA goes low while SCL high.
STOP	P	SDA goes high while SCL high.
Repeated START	Sr	SDA goes low while SCL high. It is allowable to generate a STOP before the repeated start. SDA can transition to high before or after SCL goes high in preparation for generating the START.
READ	R	Read bit = 1
WRITE	W	Write bit = 0
All other bits	—	SDA value must remain high or low during the entire time SCL is high (this is the set up and hold time in Figure 1).

In the I²C sequence diagrams in the following sections, bits produced by the master and slave are color coded as shown:

Sequence to Perform a Measurement and Read Back Result (Hold Mode)

S	Slave Address	W	A	Command Byte 1	A	Command Byte 2	A	Sr	Slave Address
R	A	Clock Stretch During Measurement	Temp MSB	A	Temp LSB	A	Checksum*	NA	P

***Note:** Reading the checksum is optional. If the checksum is not needed, then NA and STOP after the Temp LSB.

Sequence to Perform a Measurement and Read Back Result (No Hold Mode)

S	Slave Address	W	A	Command Byte 1	A	Command Byte 2	A	Sr	Slave Address			
R	NA ¹	Sr	Slave Address	R	A	Temp MSB	A	Temp LSB	A	Checksum ²	NA	P

Notes:

1. Device will NACK the slave address byte until conversion is complete.
2. Reading the checksum is optional. If the checksum is not needed then NA and STOP after the Temp LSB.

Si7057/8/9-A10

The Si7057/8/9 devices are software-compatible with Si7034 relative humidity and temperature sensor. If an ACK is sent to the Si7057/8/9 after the temp checksum, two more data bytes can be read from the Si7057/8/9 along with a second checksum value. The data contained within these two data bytes is undefined, but the 2nd checksum value will be correct for the data that is contained within the two additional data bytes.

5.2. Measuring Temperature

The results of the temperature measurement may be converted to temperature in degrees Celsius (°C) using the following expression:

$$T = -45 + 175 \times \frac{\text{Temp_Code}}{2^{16}}$$

Where:

Temperature (°C) is the measured temperature value in °C

Temp_Code is the 16-bit word returned by the Si7057/8/9

5.3. Firmware Revision

The internal firmware revision can be read with the following I²C transaction:

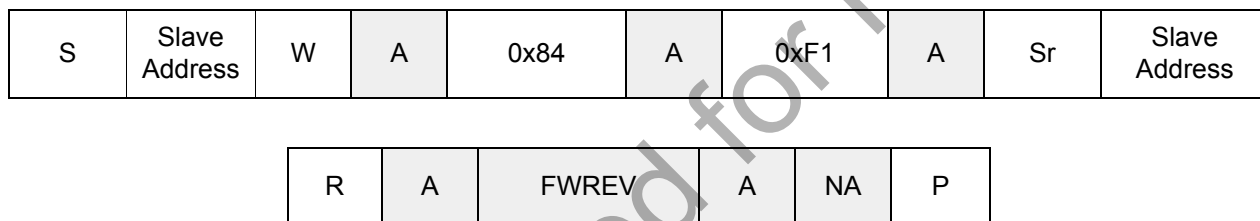

The values in this field are encoded as follows: 0x10 = Firmware version 1.0

5.4. Electronic Serial Number

The Si7057/8/9 provides a serial number individualized for each device that can be read via the I²C serial interface. Two I²C commands are required to access the device memory and retrieve the complete serial number. The command sequence, and format of the serial number response is described in the figure below:

Master	Slave
--------	-------

First access:

S	Slave Address	W	ACK	0xFA	ACK	0X0F	ACK		
S	Slave Address	R	ACK						
	SNA_3	ACK	CRC	ACK	SNA_2	ACK	CRC	ACK	
	SNA_1	ACK	CRC	ACK	SNA_0	ACK	CRC	NACK	P

2nd Access:

S	Slave Address	W	ACK	0xFC	ACK	0XC9	ACK		
S	Slave Address	R	ACK						
	SNB_3	ACK	SNB_2	ACK	CRC	ACK			
	SNB_1	ACK	SNB_0	ACK	CRC	NACK		P	

The format of the complete serial number is 64-bits in length, divided into 8 data bytes. The complete serial number sequence is shown below:

SNA_3	SNA_2	SNA_1	SNA_0	SNB_3	SNB_2	SNB_1	SNB_0
-------	-------	-------	-------	-------	-------	-------	-------

The SNB3 field contains the device identification to distinguish between the different Silicon Labs temperature devices. The value of this field maps to the following devices according to this table:

0x00 or 0xFF engineering samples

0x39 = Si7057

0x40 = Si7058

0x41 = Si7059

Si7057/8/9-A10

6. Pin Descriptions: Si7057/8/9 (Top View)

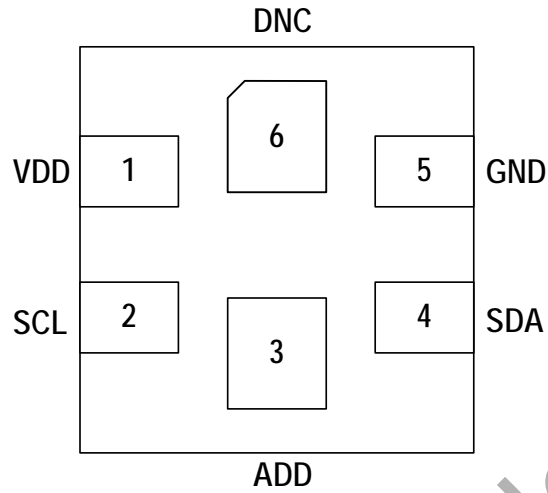

Pin Name	Pin #	Pin Description
VDD	1	Power. This pin is connected to the power supply on the circuit board.
SCL	2	I ² C clock
ADD	3	Tie this pin low for I ² C address 0x71, or tie this pin high for address 0x72.
SDA	4	I ² C data
GND	5	Ground. This pin is connected to ground on the circuit board.
DNC	6	Leave unconnected, or tie to VDD.

7. Ordering Guide

Table 11. Device Ordering Guide

Part Number	Description	Max. Accuracy	Pkg	Packing Format
Si7057-A10-IM	Digital temperature sensor	± 0.35 °C	QFN 6	Cut Tape
Si7057-A10-IMR	Digital temperature sensor	± 0.35 °C	QFN 6	Tape and Reel
Si7058-A10-IM	Digital temperature sensor	± 0.5 °C	QFN 6	Cut Tape
Si7058-A10-IMR	Digital temperature sensor	± 0.5 °C	QFN 6	Tape and Reel
Si7059-A10-IM	Digital temperature sensor	± 1.0 °C	QFN 6	Cut Tape
Si7059-A10-IMR	Digital temperature sensor	± 1.0 °C	QFN 6	Tape and Reel

8. Package Outline

8.1. Package Outline: 2x2 6-pin QFN

Figure 6 illustrates the package details for the Si7057/8/9.

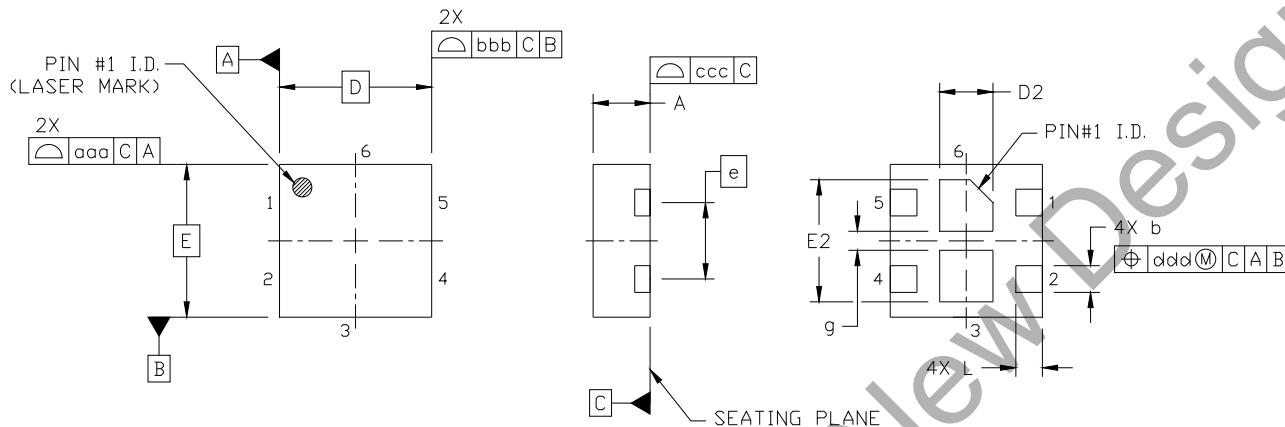

Figure 6. Si7057/8/9 Package Drawing

Table 12. Package Dimensions

Dimension	Min	Nom	Max
A	0.70	0.75	0.80
b	0.30	0.35	0.40
D	2.00 BSC		
E	2.00 BSC		
e	1.00 BSC		
D2	0.60	0.70	0.80
E2	1.50	1.60	1.70
g	0.20	0.25	0.30
L	0.30	0.35	0.40
aaa	0.10		
bbb	0.10		
ccc	0.08		
ddd	0.10		
Notes:			
1. All dimensions shown are in millimeters (mm).			
2. Dimensioning and Tolerancing per ANSI Y14.5M-1994.			

9. PCB Land Pattern and Solder Mask Design

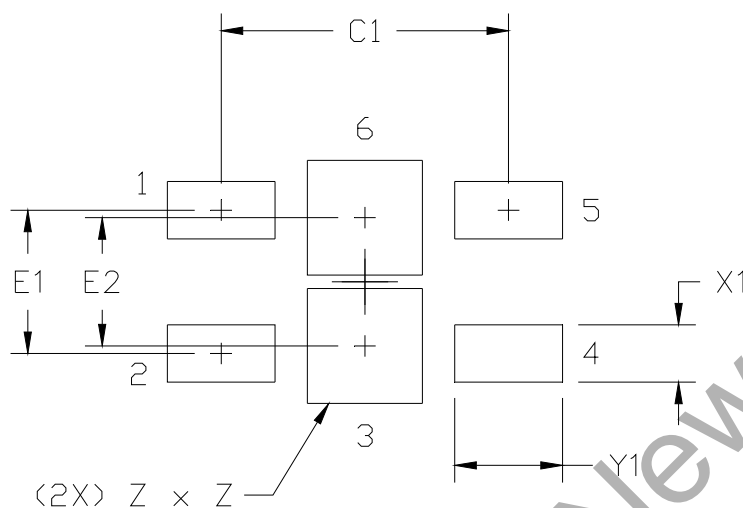

Figure 7. PCB Land Pattern Dimensions

Table 13. PCB Land Pattern Dimensions

Symbol	mm
C1	2.00
E1	1.00
E2	0.90
X1	0.40
Y1	0.75
Z	0.80

Notes:

General

1. All dimensions shown are in millimeters (mm).
2. This Land Pattern Design is based on the IPC-7351 guidelines.
3. All dimensions shown are at Maximum Material Condition (MMC). Least Material Condition (LMC) is calculated based on a Fabrication Allowance of 0.05 mm.

Solder Mask Design

4. All metal pads are to be non-solder mask defined (NSMD). Clearance between the solder mask and the metal pad is to be 60 μ m minimum, all the way around the pad.

Stencil Design

5. A stainless steel, laser-cut and electropolished stencil with trapezoidal walls should be used to assure good solder paste release.
6. The stencil thickness should be 0.125 mm (5 mils).
7. The ratio of stencil aperture to land pad size should be 1:1 for all pads.

Card Assembly

8. A No-Clean, Type-3 solder paste is recommended.
9. The recommended card reflow profile is per the JEDEC/IPC J-STD-020 specification for Small Body Components.

Si7057/8/9-A10

10. Top Marking

10.1. Si7057/8/9 Top Marking

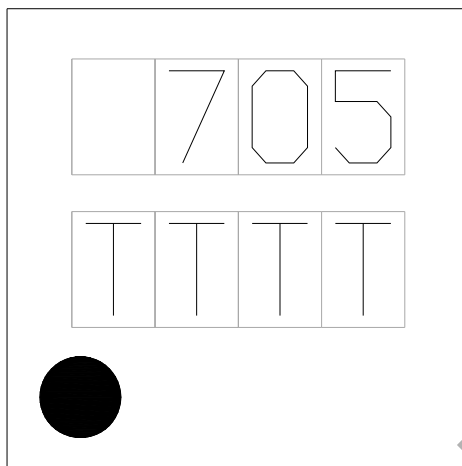

10.2. Top Marking Explanation

Mark Method:	Laser
Font Size:	0.40 mm
Line 1 Marking:	705 = Device Code
Line 2 Marking:	TTTT = Manufacturing Trace Code Digits 1–4
Line 3 Marking:	Circle = 0.35 mm Diameter

11. Additional Reference Resources

- AN607: Si70xx Humidity and Temperature Sensor Designer's Guide
- AN1026: Si70xx Temperature Sensor Designer's Guide

Not Recommended for New Designs

DOCUMENT CHANGE LIST

Revision 0.9 to Revision 1.0

- Clarified Features list on page 1.

Revision 1.0 to Revision 1.1

April 18, 2017

- Changed Si7057 max inaccuracy spec to 0.35 °C (was 0.2 °C).
- Updated Figure 2 and Figure 3.

Not Recommended for New Designs

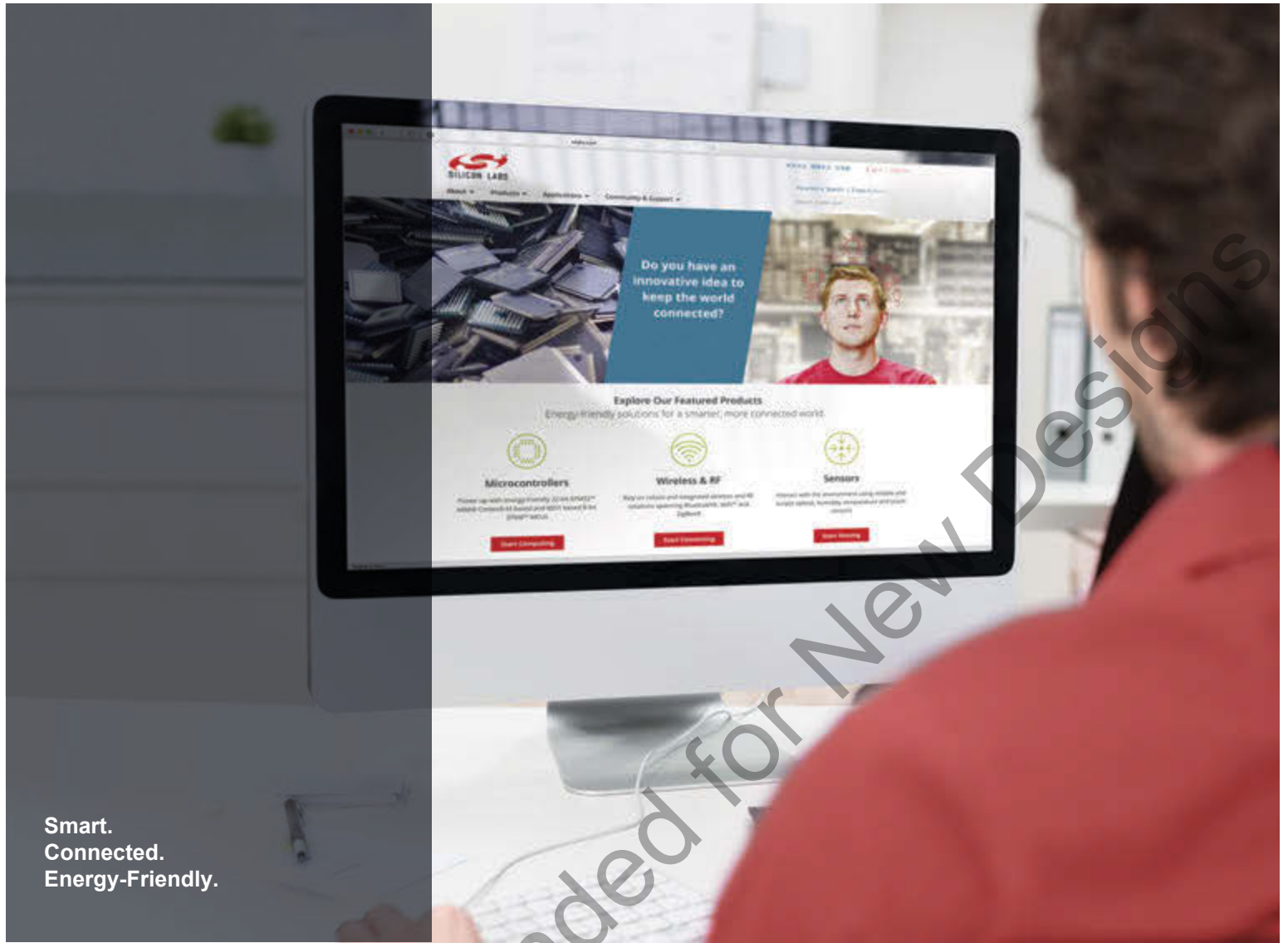

Smart.
Connected.
Energy-Friendly.



Products
www.silabs.com/products

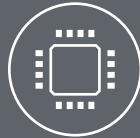

Quality
www.silabs.com/quality



Support and Community
community.silabs.com

Disclaimer

Silicon Labs intends to provide customers with the latest, accurate, and in-depth documentation of all peripherals and modules available for system and software implementers using or intending to use the Silicon Labs products. Characterization data, available modules and peripherals, memory sizes and memory addresses refer to each specific device, and "Typical" parameters provided can and do vary in different applications. Application examples described herein are for illustrative purposes only. Silicon Labs reserves the right to make changes without further notice and limitation to product information, specifications, and descriptions herein, and does not give warranties as to the accuracy or completeness of the included information. Silicon Labs shall have no liability for the consequences of use of the information supplied herein. This document does not imply or express copyright licenses granted hereunder to design or fabricate any integrated circuits. The products are not designed or authorized to be used within any Life Support System without the specific written consent of Silicon Labs. A "Life Support System" is any product or system intended to support or sustain life and/or health, which, if it fails, can be reasonably expected to result in significant personal injury or death. Silicon Labs products are not designed or authorized for military applications. Silicon Labs products shall under no circumstances be used in weapons of mass destruction including (but not limited to) nuclear, biological or chemical weapons, or missiles capable of delivering such weapons.

Trademark Information

Silicon Laboratories Inc.®, Silicon Laboratories®, Silicon Labs®, SiLabs® and the Silicon Labs logo®, Bluegiga®, Bluegiga Logo®, Clockbuilder®, CMEMS®, DSPLL®, EFM®, EFM32®, EFR®, Ember®, Energy Micro, Energy Micro logo and combinations thereof, "the world's most energy friendly microcontrollers", Ember®, EZLink®, EZRadio®, EZRadioPRO®, Gecko®, ISOModem®, Precision32®, ProSLIC®, Simplicity Studio®, SiPHY®, Telegesis, the Telegesis Logo®, USBXpress® and others are trademarks or registered trademarks of Silicon Labs. ARM, CORTEX, Cortex-M3 and THUMB are trademarks or registered trademarks of ARM Holdings. Keil is a registered trademark of ARM Limited. All other products or brand names mentioned herein are trademarks of their respective holders.



SILICON LABS

Silicon Laboratories Inc.
400 West Cesar Chavez
Austin, TX 78701
USA

<http://www.silabs.com>