



# PCA9671

Remote 16-bit I/O expander for Fm+ I<sup>2</sup>C-bus with reset

Rev. 2 — 29 July 2010

Product data sheet

## 1. General description

The PCA9671 provides general purpose remote I/O expansion for most microcontroller families via the two-line bidirectional bus (I<sup>2</sup>C-bus) and is a part of the Fast-mode Plus (Fm+) family.

The PCA9671 is a drop in upgrade for the PCF8575 providing higher I<sup>2</sup>C-bus speeds (1 MHz versus 400 kHz) so that the output can support PWM dimming of LEDs, higher I<sup>2</sup>C-bus drive (30 mA versus 3 mA) so that many more devices can be on the bus without the need for bus buffers, higher total package sink capacity (400 mA versus 100 mA) that supports having all 25 mA LEDs on at the same time and more device addresses (64 versus 8) to allow many more devices on the bus without address conflicts.

The difference between the PCA9671 and the PCF8575 is that the interrupt output on the PCF8575 is replaced by a RESET input on the PCA9671.

The device consists of a 16-bit quasi-bidirectional port and an I<sup>2</sup>C-bus interface. The PCA9671 has a low current consumption and includes latched outputs with 25 mA high current drive capability for directly driving LEDs. The internal Power-On Reset (POR), hardware reset pin ( $\overline{\text{RESET}}$ ) or software reset sequence initializes the I/Os as inputs.

## 2. Features and benefits

- 1 MHz I<sup>2</sup>C-bus interface
- Compliant with the I<sup>2</sup>C-bus Fast-mode and Standard-mode
- SDA with 30 mA sink capability for 4000 pF buses
- 2.3 V to 5.5 V operation with 5.5 V tolerant I/Os
- 16-bit remote I/O pins that default to inputs at power-up
- Latched outputs with 25 mA sink capability for directly driving LEDs
- Total package sink capability of 400 mA
- Active LOW reset input
- 64 programmable slave addresses using 3 address pins
- Readable device ID (manufacturer, device type, and revision)
- Low standby current
- -40 °C to +85 °C operation
- ESD protection exceeds 2000 V HBM per JESD22-A114, 200 V MM per JESD22-A115, and 1000 V CDM per JESD22-C101
- Latch-up testing is done to JEDEC standard JESD78 which exceeds 100 mA
- Packages offered: SO24, SSOP24, QSOP24, TSSOP24, HVQFN24, DHVQFN24



### 3. Applications

- LED signs and displays
- Servers
- Industrial control
- Medical equipment
- PLCs
- Cellular telephones
- Gaming machines
- Instrumentation and test measurement

### 4. Ordering information

**Table 1. Ordering information**

Type number	Topside mark	Package		
		Name	Description	Version
PCA9671D	PCA9671D	SO24	plastic small outline package; 24 leads; body width 7.5 mm	SOT137-1
PCA9671DB	PCA9671DB	SSOP24	plastic shrink small outline package; 24 leads; body width 5.3 mm	SOT340-1
PCA9671DK	PCA9671	SSOP24 <sup>[1]</sup>	plastic shrink small outline package; 24 leads; body width 3.9 mm; lead pitch 0.635 mm	SOT556-1
PCA9671PW	PCA9671PW	TSSOP24	plastic thin shrink small outline package; 24 leads; body width 4.4 mm	SOT355-1
PCA9671BQ	9671	DHVQFN24	plastic dual in-line compatible thermal enhanced very thin quad flat package; no leads; 24 terminals; body 3.5 × 5.5 × 0.85 mm	SOT815-1
PCA9671BS	9671	HVQFN24	plastic thermal enhanced very thin quad flat package; no leads; 24 terminals; body 4 × 4 × 0.85 mm	SOT616-1

[1] Also known as QSOP24.

### 5. Block diagram

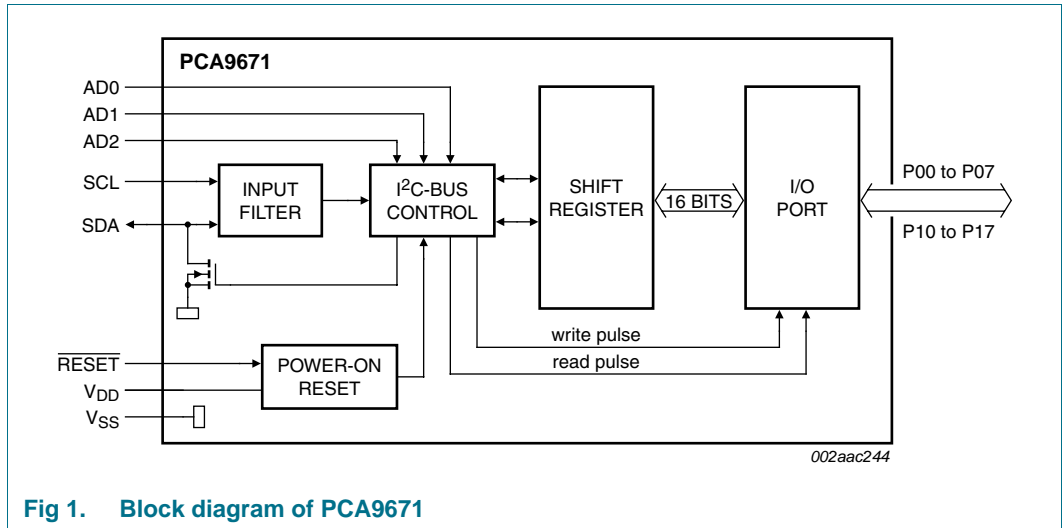

Fig 1. Block diagram of PCA9671

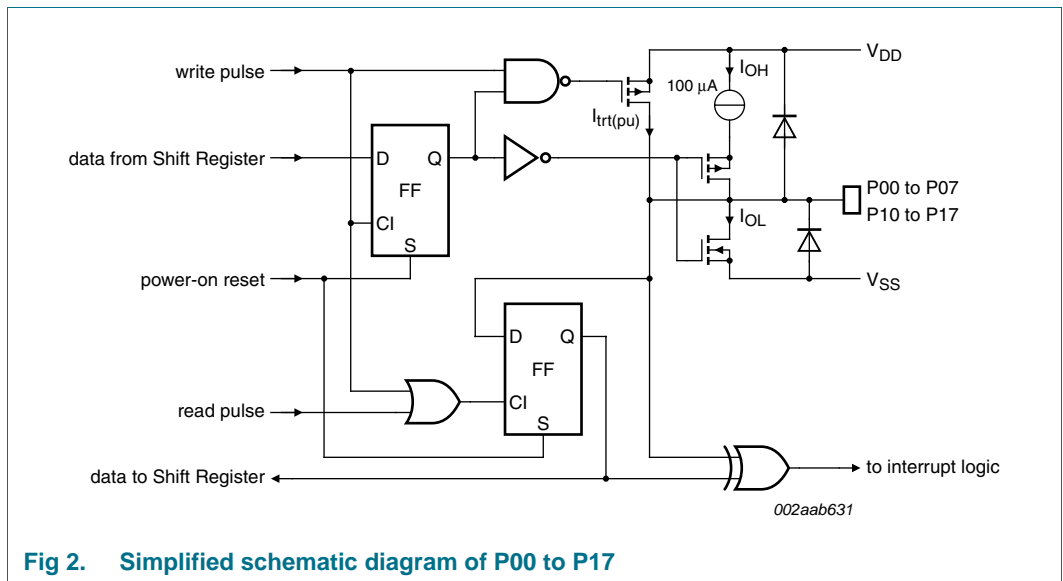
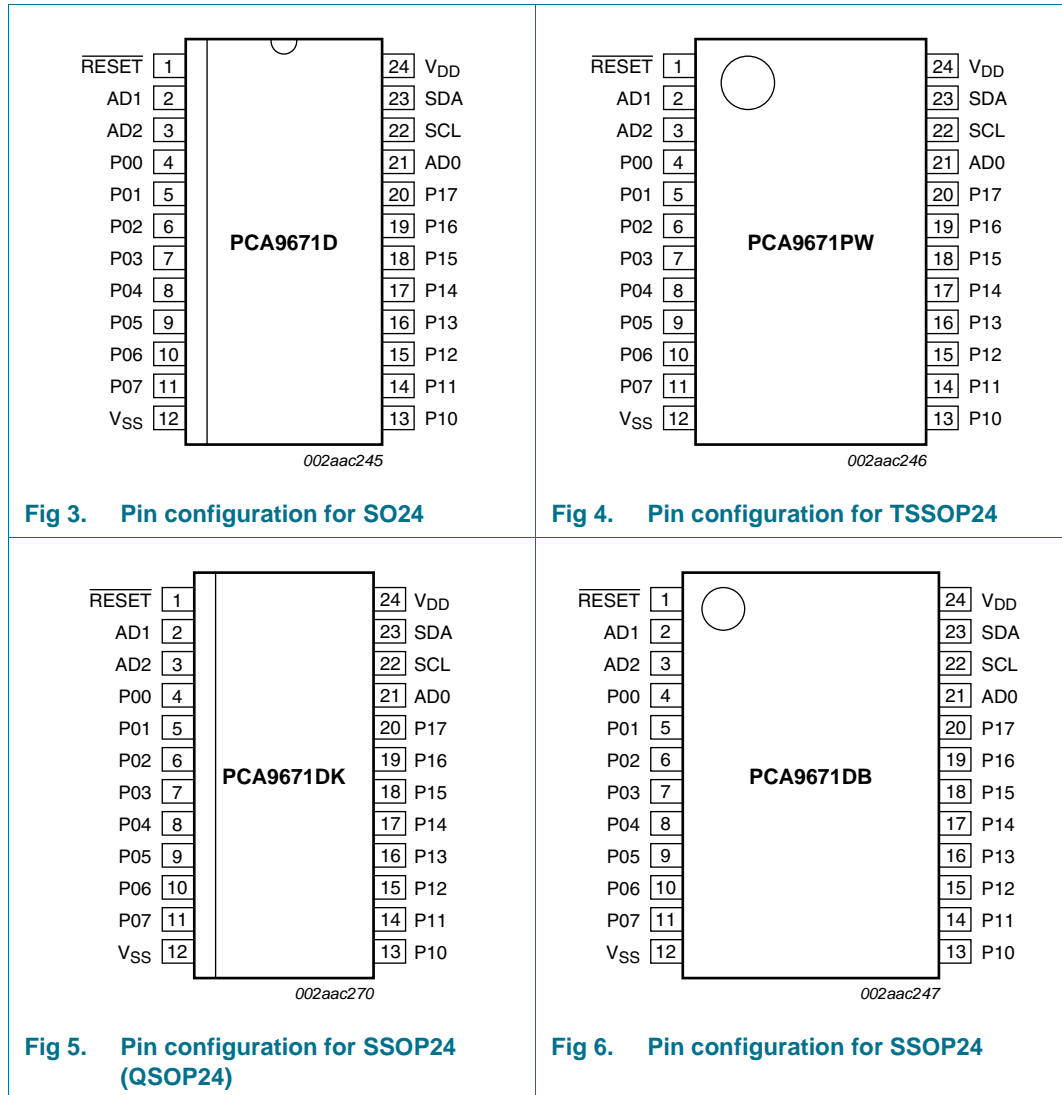

Fig 2. Simplified schematic diagram of P00 to P17

## 6. Pinning information

### 6.1 Pinning



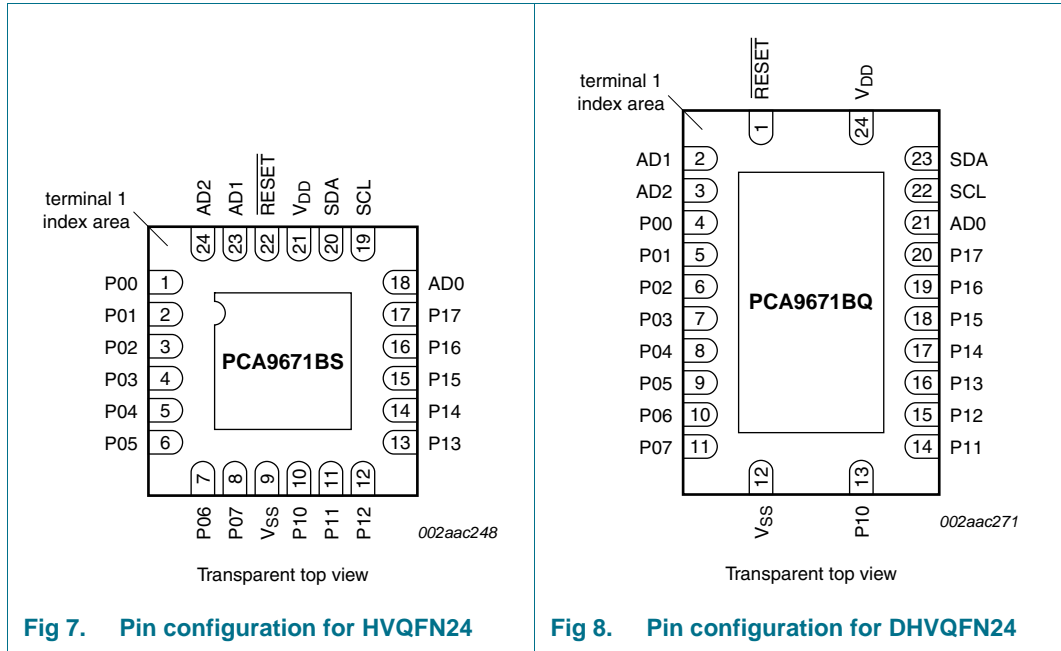

Fig 7. Pin configuration for HVQFN24

Fig 8. Pin configuration for DHVQFN24

6.2 Pin description

Table 2. Pin description

Symbol	Pin		Description
	SO24, SSOP24, QSOP24, TSSOP24, DHVQFN24	HVQFN24	
RESET	1	22	reset input (active LOW)
AD1	2	23	address input 1
AD2	3	24	address input 2
P00	4	1	quasi-bidirectional I/O 00
P01	5	2	quasi-bidirectional I/O 01
P02	6	3	quasi-bidirectional I/O 02
P03	7	4	quasi-bidirectional I/O 03
P04	8	5	quasi-bidirectional I/O 04
P05	9	6	quasi-bidirectional I/O 05
P06	10	7	quasi-bidirectional I/O 06
P07	11	8	quasi-bidirectional I/O 07
V <sub>SS</sub>	12 <sup>[1]</sup>	9 <sup>[1]</sup>	supply ground
P10	13	10	quasi-bidirectional I/O 10
P11	14	11	quasi-bidirectional I/O 11
P12	15	12	quasi-bidirectional I/O 12
P13	16	13	quasi-bidirectional I/O 13
P14	17	14	quasi-bidirectional I/O 14
P15	18	15	quasi-bidirectional I/O 15
P16	19	16	quasi-bidirectional I/O 16
P17	20	17	quasi-bidirectional I/O 17

Table 2. Pin description ...continued

Symbol	Pin		Description
	SO24, SSOP24, QSOP24, TSSOP24, DHVQFN24	HVQFN24	
AD0	21	18	address input 0
SCL	22	19	serial clock line input
SDA	23	20	serial data line input/output
V <sub>DD</sub>	24	21	supply voltage

[1] HVQFN and DHVQFN package die supply ground is connected to both the V<sub>SS</sub> pin and the exposed center pad. The V<sub>SS</sub> pin must be connected to supply ground for proper device operation. For enhanced thermal, electrical, and board-level performance, the exposed pad needs to be soldered to the board using a corresponding thermal pad on the board, and for proper heat conduction through the board thermal vias need to be incorporated in the PCB in the thermal pad region.

## 7. Functional description

Refer to [Figure 1 “Block diagram of PCA9671”](#).

### 7.1 Device address

Following a START condition, the bus master must send the address of the slave it is accessing and the operation it wants to perform (read or write). The address of the PCA9671 is shown in [Figure 9](#). Slave address pins AD2, AD1, and AD0 choose 1 of 64 slave addresses. To conserve power, no internal pull-up resistors are incorporated on AD2, AD1, and AD0. Address values depending on AD2, AD1, and AD0 can be found in [Table 3 “PCA9671 address map”](#).

**Remark:** The General Call address (0000 0000) and the Device ID address (1111 100X) are reserved and cannot be used as device address. Failure to follow this requirement will cause the PCA9671 not to acknowledge.

**Remark:** Reserved I<sup>2</sup>C-bus addresses must be used with caution since they can interfere with:

- “reserved for future use” I<sup>2</sup>C-bus addresses (0000 011, 1111 101, 1111 110, 1111 111)
- slave devices that use the 10-bit addressing scheme (1111 0xx)
- High speed mode (Hs-mode) master code (0000 1xx)

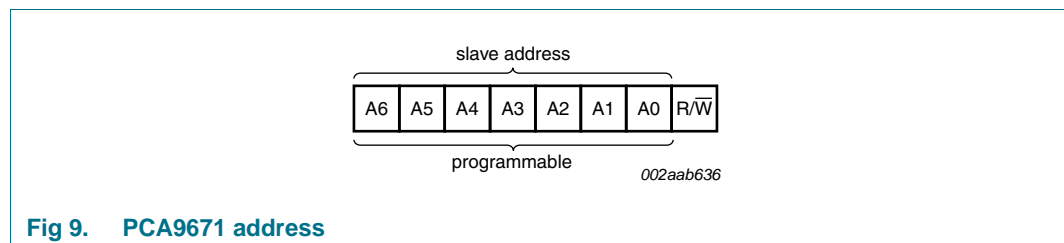

Fig 9. PCA9671 address

The last bit of the first byte defines the operation to be performed. When set to logic 1 a read is selected, while a logic 0 selects a write operation.

When AD2, AD1 and AD0 are held to V<sub>DD</sub> or V<sub>SS</sub>, the same address as the PCF8575 is applied.

## 7.1.1 Address maps

Table 3. PCA9671 address map

AD2	AD1	AD0	A6	A5	A4	A3	A2	A1	A0	Address (hex)
V <sub>SS</sub>	SCL	V <sub>SS</sub>	0	0	1	0	0	0	0	20h
V <sub>SS</sub>	SCL	V <sub>DD</sub>	0	0	1	0	0	0	1	22h
V <sub>SS</sub>	SDA	V <sub>SS</sub>	0	0	1	0	0	1	0	24h
V <sub>SS</sub>	SDA	V <sub>DD</sub>	0	0	1	0	0	1	1	26h
V <sub>DD</sub>	SCL	V <sub>SS</sub>	0	0	1	0	1	0	0	28h
V <sub>DD</sub>	SCL	V <sub>DD</sub>	0	0	1	0	1	0	1	2Ah
V <sub>DD</sub>	SDA	V <sub>SS</sub>	0	0	1	0	1	1	0	2Ch
V <sub>DD</sub>	SDA	V <sub>DD</sub>	0	0	1	0	1	1	1	2Eh
V <sub>SS</sub>	SCL	SCL	0	0	1	1	0	0	0	30h
V <sub>SS</sub>	SCL	SDA	0	0	1	1	0	0	1	32h
V <sub>SS</sub>	SDA	SCL	0	0	1	1	0	1	0	34h
V <sub>SS</sub>	SDA	SDA	0	0	1	1	0	1	1	36h
V <sub>DD</sub>	SCL	SCL	0	0	1	1	1	0	0	38h
V <sub>DD</sub>	SCL	SDA	0	0	1	1	1	0	1	3Ah
V <sub>DD</sub>	SDA	SCL	0	0	1	1	1	1	0	3Ch
V <sub>DD</sub>	SDA	SDA	0	0	1	1	1	1	1	3Eh
V <sub>SS</sub>	V <sub>SS</sub>	V <sub>SS</sub>	0	1	0	0	0	0	0	40h
V <sub>SS</sub>	V <sub>SS</sub>	V <sub>DD</sub>	0	1	0	0	0	0	1	42h
V <sub>SS</sub>	V <sub>DD</sub>	V <sub>SS</sub>	0	1	0	0	0	1	0	44h
V <sub>SS</sub>	V <sub>DD</sub>	V <sub>DD</sub>	0	1	0	0	0	1	1	46h
V <sub>DD</sub>	V <sub>SS</sub>	V <sub>SS</sub>	0	1	0	0	1	0	0	48h
V <sub>DD</sub>	V <sub>SS</sub>	V <sub>DD</sub>	0	1	0	0	1	0	1	4Ah
V <sub>DD</sub>	V <sub>DD</sub>	V <sub>SS</sub>	0	1	0	0	1	1	0	4Ch
V <sub>DD</sub>	V <sub>DD</sub>	V <sub>DD</sub>	0	1	0	0	1	1	1	4Eh
V <sub>SS</sub>	V <sub>SS</sub>	SCL	0	1	0	1	0	0	0	50h
V <sub>SS</sub>	V <sub>SS</sub>	SDA	0	1	0	1	0	0	1	52h
V <sub>SS</sub>	V <sub>DD</sub>	SCL	0	1	0	1	0	1	0	54h
V <sub>SS</sub>	V <sub>DD</sub>	SDA	0	1	0	1	0	1	1	56h
V <sub>DD</sub>	V <sub>SS</sub>	SCL	0	1	0	1	1	0	0	58h
V <sub>DD</sub>	V <sub>SS</sub>	SDA	0	1	0	1	1	0	1	5Ah
V <sub>DD</sub>	V <sub>DD</sub>	SCL	0	1	0	1	1	1	0	5Ch
V <sub>DD</sub>	V <sub>DD</sub>	SDA	0	1	0	1	1	1	1	5Eh

Table 3. PCA9671 address map ...continued

AD2	AD1	AD0	A6	A5	A4	A3	A2	A1	A0	Address (hex)
SCL	SCL	V <sub>SS</sub>	1	0	1	0	0	0	0	A0h
SCL	SCL	V <sub>DD</sub>	1	0	1	0	0	0	1	A2h
SCL	SDA	V <sub>SS</sub>	1	0	1	0	0	1	0	A4h
SCL	SDA	V <sub>DD</sub>	1	0	1	0	0	1	1	A6h
SDA	SCL	V <sub>SS</sub>	1	0	1	0	1	0	0	A8h
SDA	SCL	V <sub>DD</sub>	1	0	1	0	1	0	1	AAh
SDA	SDA	V <sub>SS</sub>	1	0	1	0	1	1	0	ACh
SDA	SDA	V <sub>DD</sub>	1	0	1	0	1	1	1	A Eh
SCL	SCL	SCL	1	0	1	1	0	0	0	B0h
SCL	SCL	SDA	1	0	1	1	0	0	1	B2h
SCL	SDA	SCL	1	0	1	1	0	1	0	B4h
SCL	SDA	SDA	1	0	1	1	0	1	1	B6h
SDA	SCL	SCL	1	0	1	1	1	0	0	B8h
SDA	SCL	SDA	1	0	1	1	1	0	1	BAh
SDA	SDA	SCL	1	0	1	1	1	1	0	BCh
SDA	SDA	SDA	1	0	1	1	1	1	1	BEh
SCL	V <sub>SS</sub>	V <sub>SS</sub>	1	1	0	0	0	0	0	C0h
SCL	V <sub>SS</sub>	V <sub>DD</sub>	1	1	0	0	0	0	1	C2h
SCL	V <sub>DD</sub>	V <sub>SS</sub>	1	1	0	0	0	1	0	C4h
SCL	V <sub>DD</sub>	V <sub>DD</sub>	1	1	0	0	0	1	1	C6h
SDA	V <sub>SS</sub>	V <sub>SS</sub>	1	1	0	0	1	0	0	C8h
SDA	V <sub>SS</sub>	V <sub>DD</sub>	1	1	0	0	1	0	1	CAh
SDA	V <sub>DD</sub>	V <sub>SS</sub>	1	1	0	0	1	1	0	CCh
SDA	V <sub>DD</sub>	V <sub>DD</sub>	1	1	0	0	1	1	1	CEh
SCL	V <sub>SS</sub>	SCL	1	1	1	0	0	0	0	E0h
SCL	V <sub>SS</sub>	SDA	1	1	1	0	0	0	1	E2h
SCL	V <sub>DD</sub>	SCL	1	1	1	0	0	1	0	E4h
SCL	V <sub>DD</sub>	SDA	1	1	1	0	0	1	1	E6h
SDA	V <sub>SS</sub>	SCL	1	1	1	0	1	0	0	E8h
SDA	V <sub>SS</sub>	SDA	1	1	1	0	1	0	1	E Ah
SDA	V <sub>DD</sub>	SCL	1	1	1	0	1	1	0	E Ch
SDA	V <sub>DD</sub>	SDA	1	1	1	0	1	1	1	E Eh



**7.2 Software Reset call, and device ID addresses**

Two other different addresses can be sent to the PCA9671.

- General Call address: allows to reset the PCA9671 through the I<sup>2</sup>C-bus upon reception of the right I<sup>2</sup>C-bus sequence. See [Section 7.2.1 “Software Reset”](#) for more information.
- Device ID address: allows to read ID information from the device (manufacturer, part identification, revision). See [Section 7.2.2 “Device ID \(PCA9671 ID field\)”](#) for more information.

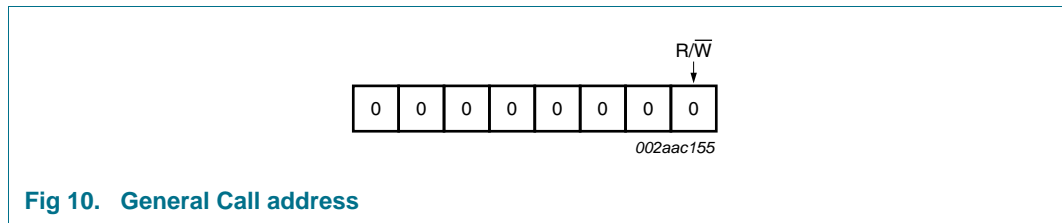

**Fig 10. General Call address**

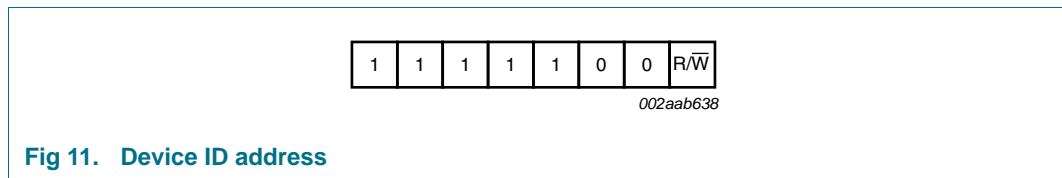

**Fig 11. Device ID address**

**7.2.1 Software Reset**

The Software Reset Call allows all the devices in the I<sup>2</sup>C-bus to be reset to the power-up state value through a specific formatted I<sup>2</sup>C-bus command. To be performed correctly, it implies that the I<sup>2</sup>C-bus is functional and that there is no device hanging the bus.

The Software Reset sequence is defined as following:

1. A START command is sent by the I<sup>2</sup>C-bus master.
2. The reserved General Call I<sup>2</sup>C-bus address ‘0000 000’ with the R/W bit set to logic 0 (write) is sent by the I<sup>2</sup>C-bus master.
3. The PCA9671 device(s) acknowledge(s) after seeing the General Call address ‘0000 0000’ (00h) only. If the R/W bit is set to logic 1 (read), no acknowledge is returned to the I<sup>2</sup>C-bus master.
4. Once the General Call address has been sent and acknowledged, the master sends 1 byte. The value of the byte must be equal to 06h.
  - a. The PCA9671 acknowledges this value only. If the byte is not equal to 06h, the PCA9671 does not acknowledge it.

If more than 1 byte of data is sent, the PCA9671 does not acknowledge any more.

5. Once the right byte has been sent and correctly acknowledged, the master sends a STOP command to end the Software Reset sequence: the PCA9671 then resets to the default value (power-up value) and is ready to be addressed again within the specified bus free time. If the master sends a Repeated START instead, no reset is performed.

The I<sup>2</sup>C-bus master must interpret a non-acknowledge from the PCA9671 (at any time) as a 'Software Reset Abort'. The PCA9671 does not initiate a reset of its registers.

The unique sequence that initiates a Software Reset is described in [Figure 12](#).

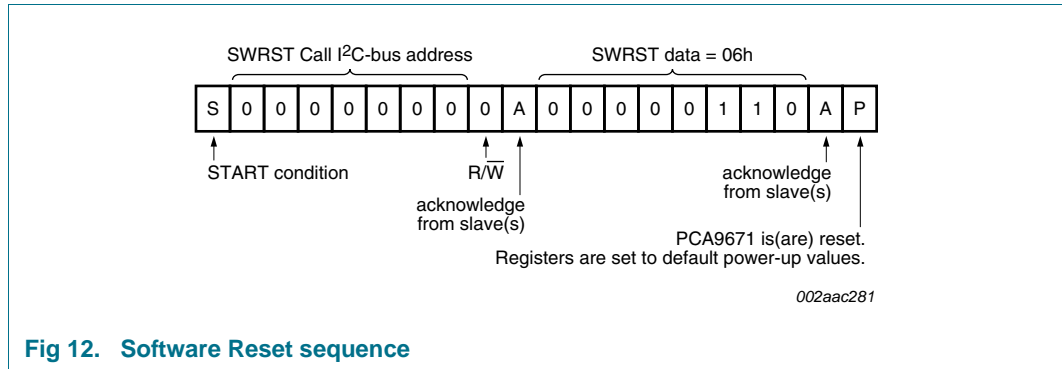

Fig 12. Software Reset sequence

### 7.2.2 Device ID (PCA9671 ID field)

The Device ID field is a 3-byte read-only (24 bits) word giving the following information:

- 8 bits with the manufacturer name, unique per manufacturer (for example, NXP Semiconductors).
- 13 bits with the part identification, assigned by manufacturer, the 7 MSBs with the category ID and the 6 LSBs with the feature ID (for example, PCA9671 16-bit quasi-output I/O expander).
- 3 bits with the die revision, assigned by manufacturer (for example, Rev X).

The Device ID is read-only, hardwired in the device and can be accessed as follows:

1. START command.
2. The master sends the Reserved Device ID I<sup>2</sup>C-bus address '1111 100' with the R/W bit set to logic 0 (write).
3. The master sends the I<sup>2</sup>C-bus slave address of the slave device it needs to identify. The LSB is a 'Don't care' value. Only one device must acknowledge this byte (the one that has the I<sup>2</sup>C-bus slave address).
4. The master sends a Re-START command.

**Remark:** A STOP command followed by a START command will reset the slave state machine and the Device ID read cannot be performed.

**Remark:** A STOP command or a Re-START command followed by an access to another slave device will reset the slave state machine and the Device ID read cannot be performed.

5. The master sends the Reserved Device ID I<sup>2</sup>C-bus address '1111 100' with the R/W bit set to logic 1 (read).
6. The device ID read can be done, starting with the 8 manufacturer bits (first byte + 4 MSB of the second byte), followed by the 13 part identification bits and then the 3 die revision bits (3 LSB of the third byte).
7. The master ends the reading sequence by NACKing the last byte, thus resetting the slave device state machine and allowing the master to send the STOP command.

**Remark:** The reading of the Device ID can be stopped anytime by sending a NACK command.

**Remark:** If the master continues to ACK the bytes after the third byte, the PCA9671 rolls back to the first byte and keeps sending the Device ID sequence until a NACK has been detected.

For the PCA9671, the Device ID is as shown in [Figure 13](#).

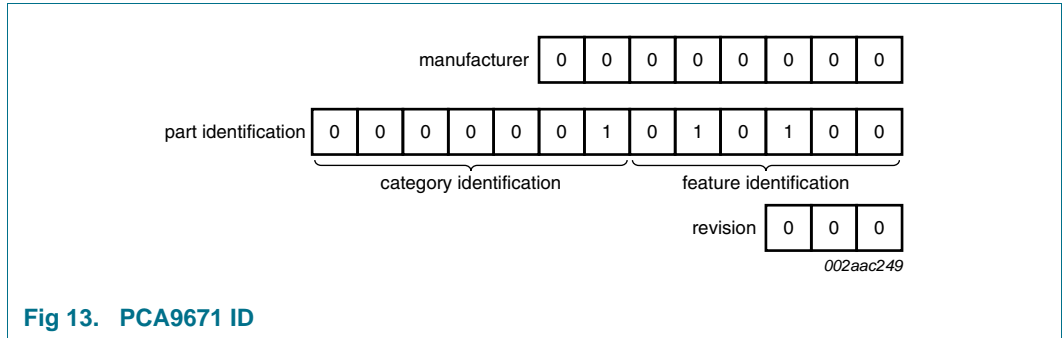

Fig 13. PCA9671 ID

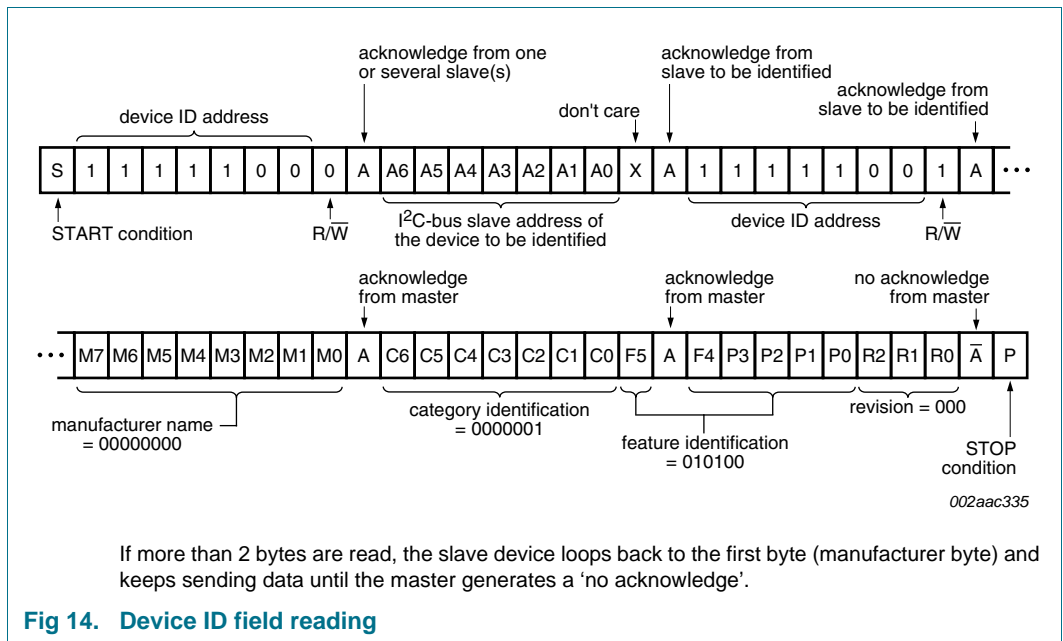

Fig 14. Device ID field reading

## 8. I/O programming

### 8.1 Quasi-bidirectional I/O architecture

The PCA9671's 16 ports (see [Figure 2](#)) are entirely independent and can be used either as input or output ports. Input data is transferred from the ports to the microcontroller in the Read mode (see [Figure 17](#)). Output data is transmitted to the ports in the Write mode (see [Figure 16](#)).

Every data transmission from the PCA9671 must consist of an even number of bytes, the first byte will be referred to as P07 to P00, and the second byte as P17 to P10. The third will be referred to as P07 to P00, and so on.

This quasi-bidirectional I/O can be used as an input or output without the use of a control signal for data directions. At power-on the I/Os are HIGH. In this mode only a current source ( $I_{OH}$ ) to  $V_{DD}$  is active. An additional strong pull-up to  $V_{DD}$  ( $I_{trt(pu)}$ ) allows fast rising edges into heavily loaded outputs. These devices turn on when an output is written HIGH, and are switched off by the negative edge of SCL. The I/Os should be HIGH before being used as inputs. After power-on, as all the I/Os are set HIGH, all of them can be used as inputs. Any change in setting of the I/Os as either inputs or outputs can be done with the write mode.

**Remark:** If a HIGH is applied to an I/O which has been written earlier to LOW, a large current ( $I_{OL}$ ) will flow to  $V_{SS}$ .

### 8.2 Writing to the port (Output mode)

To write, the master (microcontroller) first addresses the slave device. By setting the last bit of the byte containing the slave address to logic 0 the Write mode is entered. The PCA9671 acknowledges and the master sends the first data byte for P07 to P00. After the first data byte is acknowledged by the PCA9671, the second data byte P17 to P10 is sent by the master. Once again, the PCA9671 acknowledges the receipt of the data. Each 8-bit data is presented on the port lines after it has been acknowledged by the PCA9671.

The number of data bytes that can be sent successively is not limited. After every two bytes, the previous data is overwritten.

The first data byte in every pair refers to Port 0 (P07 to P00), whereas the second data byte in every pair refers to Port 1 (P17 to P10). See [Figure 15](#).

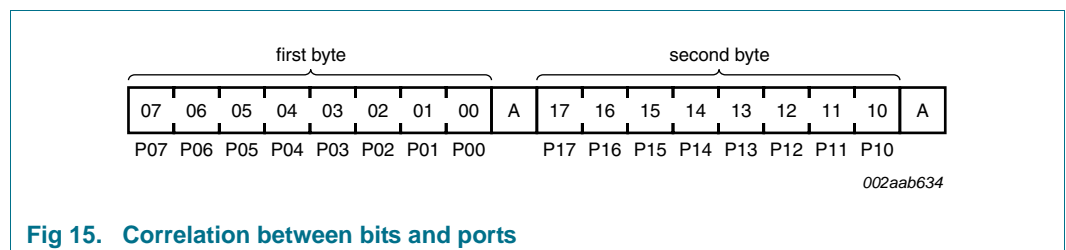

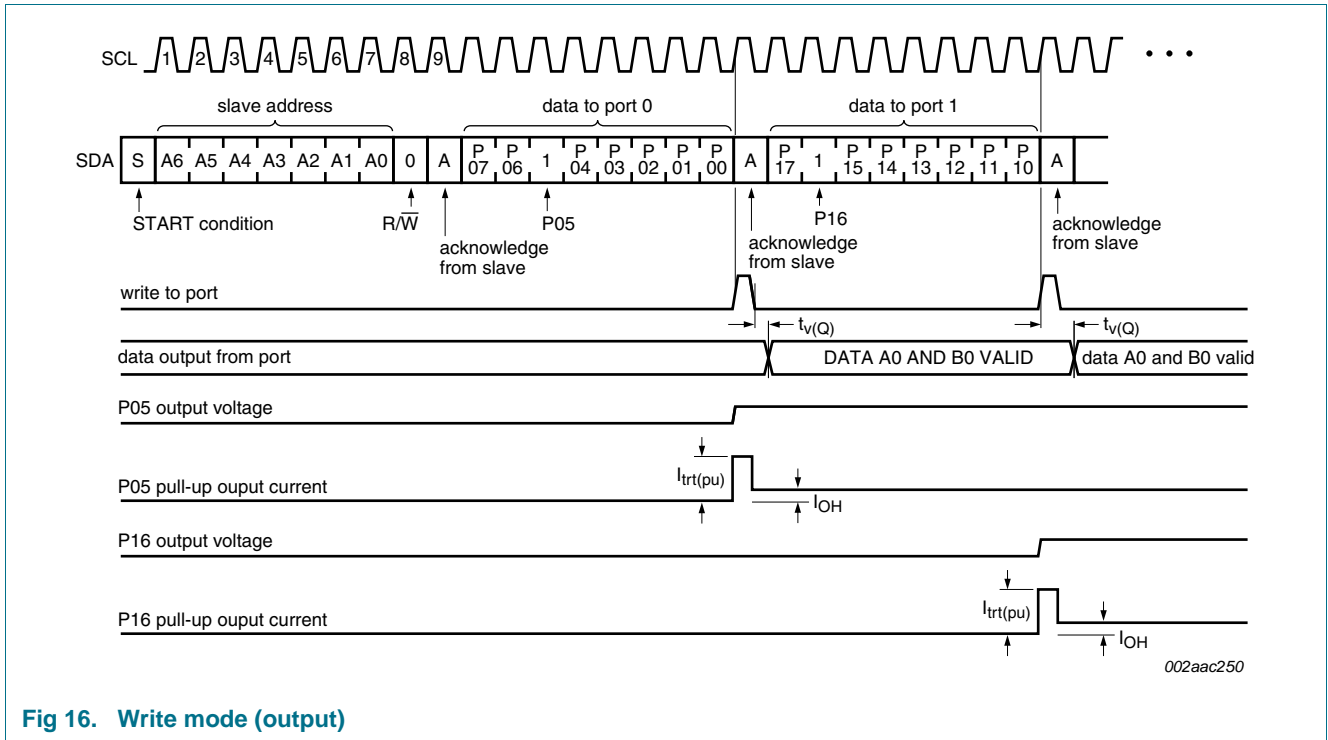
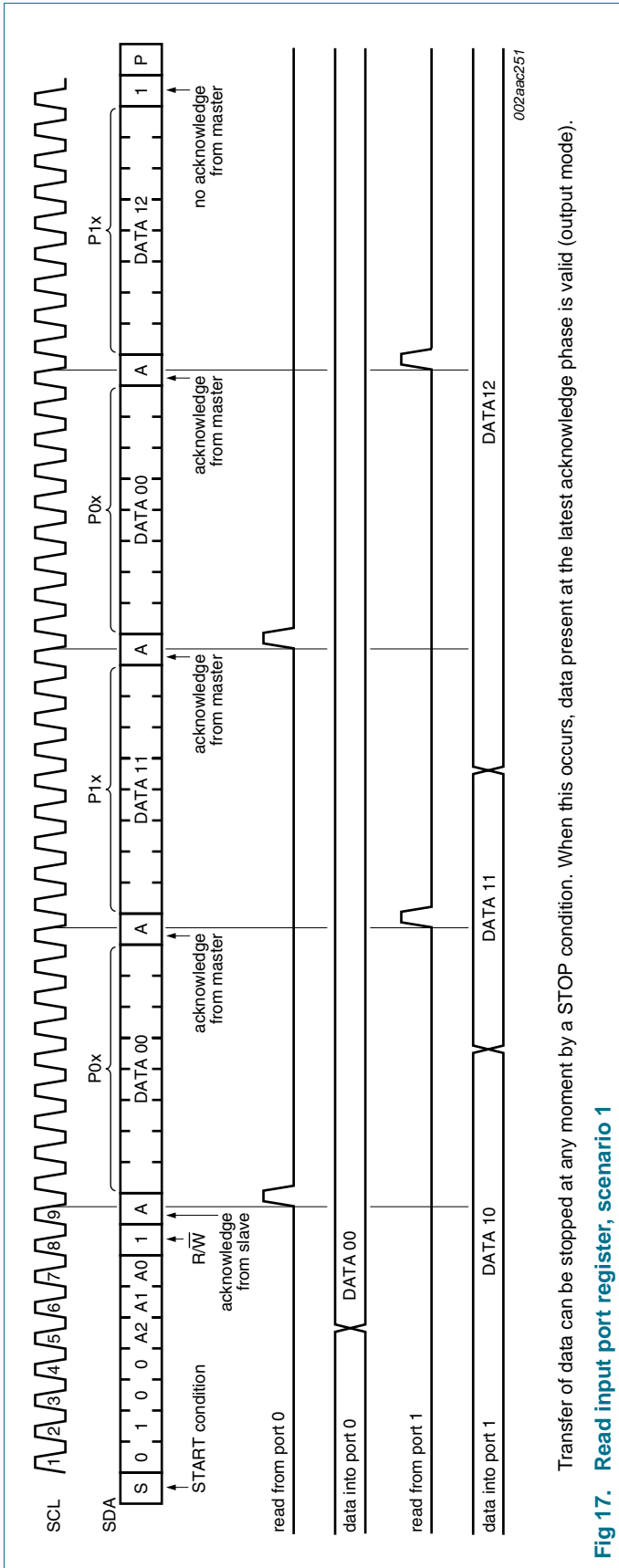

Fig 16. Write mode (output)

### 8.3 Reading from a port (Input mode)

All ports programmed as input should be set to logic 1. To read, the master (microcontroller) first addresses the slave device after it receives the interrupt. By setting the last bit of the byte containing the slave address to logic 1 the Read mode is entered. The data bytes that follow on the SDA are the values on the ports.

If the data on the input port changes faster than the master can read, this data may be lost.



Transfer of data can be stopped at any moment by a STOP condition. When this occurs, data present at the latest acknowledge phase is valid (output mode).

Fig 17. Read input port register, scenario 1

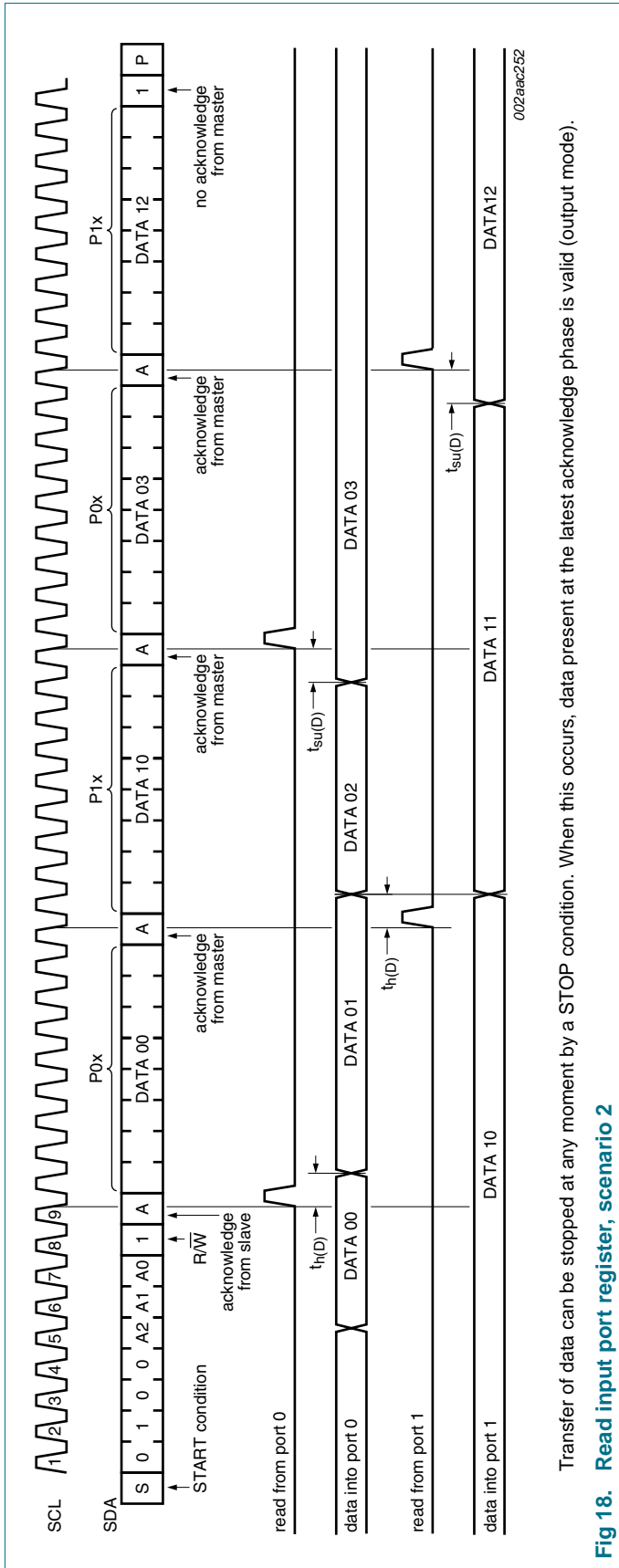

Transfer of data can be stopped at any moment by a STOP condition. When this occurs, data present at the latest acknowledge phase is valid (output mode).

Fig 18. Read input port register, scenario 2

### 8.4 Power-on reset

When power is applied to  $V_{DD}$ , an internal Power-On Reset (POR) holds the PCA9671 in a reset condition until  $V_{DD}$  has reached  $V_{POR}$ . At that point, the reset condition is released and the PCA9671 registers and I<sup>2</sup>C-bus/SMBus state machine will initialize to their default states. Thereafter  $V_{DD}$  must be lowered below 0.2 V to reset the device.

### 8.5 RESET input

A reset can be accomplished by holding the  $\overline{\text{RESET}}$  pin LOW for a minimum of  $t_{w(\text{rst})}$ . The PCA9671 registers and I<sup>2</sup>C-bus state machine will be held in their default state until the RESET input is once again HIGH.

## 9. Characteristics of the I<sup>2</sup>C-bus

The I<sup>2</sup>C-bus is for 2-way, 2-line communication between different ICs or modules. The two lines are a serial data line (SDA) and a serial clock line (SCL). Both lines must be connected to a positive supply via a pull-up resistor when connected to the output stages of a device. Data transfer may be initiated only when the bus is not busy.

### 9.1 Bit transfer

One data bit is transferred during each clock pulse. The data on the SDA line must remain stable during the HIGH period of the clock pulse as changes in the data line at this time will be interpreted as control signals (see [Figure 19](#)).

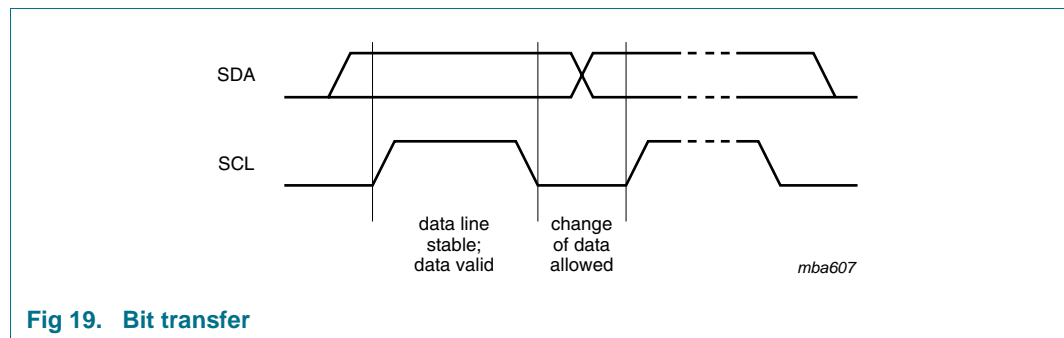

Fig 19. Bit transfer

#### 9.1.1 START and STOP conditions

Both data and clock lines remain HIGH when the bus is not busy. A HIGH-to-LOW transition of the data line while the clock is HIGH is defined as the START condition (S). A LOW-to-HIGH transition of the data line while the clock is HIGH is defined as the STOP condition (P) (see [Figure 20](#)).



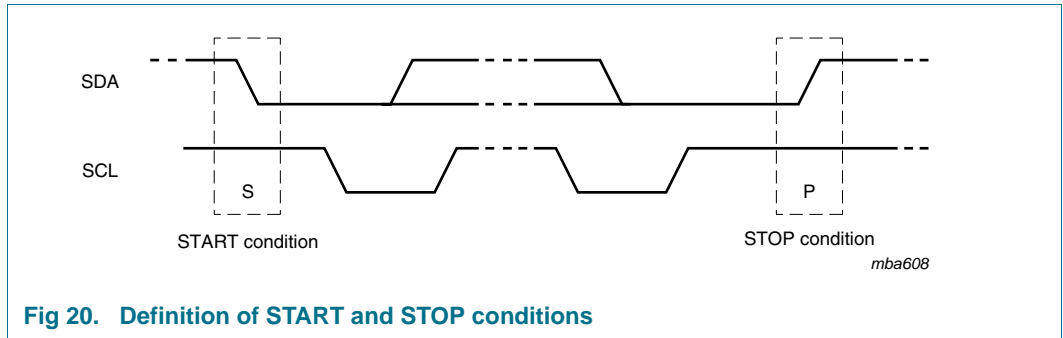

Fig 20. Definition of START and STOP conditions

### 9.2 System configuration

A device generating a message is a ‘transmitter’; a device receiving is the ‘receiver’. The device that controls the message is the ‘master’ and the devices which are controlled by the master are the ‘slaves’ (see [Figure 21](#)).

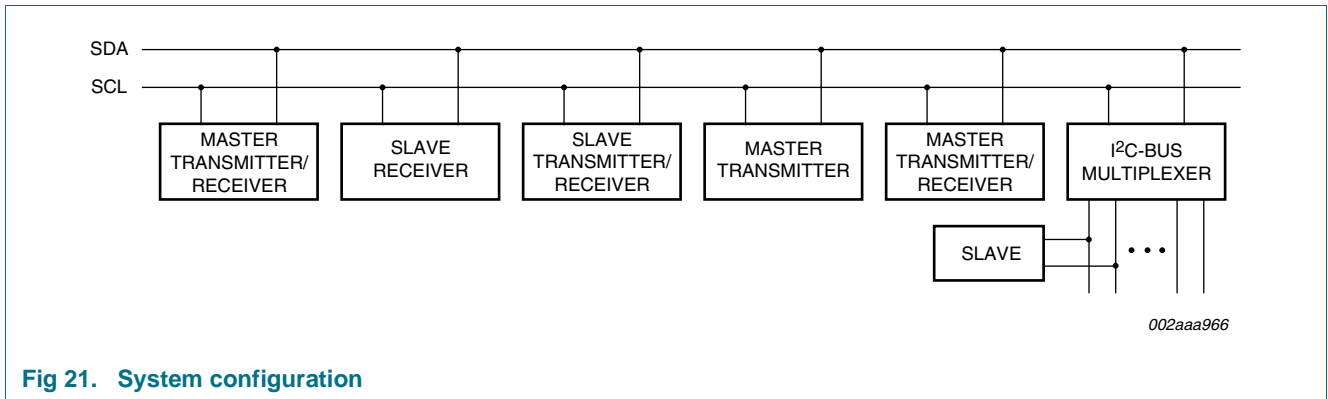

Fig 21. System configuration

### 9.3 Acknowledge

The number of data bytes transferred between the START and the STOP conditions from transmitter to receiver is not limited. Each byte of eight bits is followed by one acknowledge bit. The acknowledge bit is a HIGH level put on the bus by the transmitter, whereas the master generates an extra acknowledge related clock pulse.

A slave receiver which is addressed must generate an acknowledge after the reception of each byte. Also a master must generate an acknowledge after the reception of each byte that has been clocked out of the slave transmitter. The device that acknowledges has to pull down the SDA line during the acknowledge clock pulse, so that the SDA line is stable LOW during the HIGH period of the acknowledge related clock pulse; set-up and hold times must be taken into account.

A master receiver must signal an end of data to the transmitter by not generating an acknowledge on the last byte that has been clocked out of the slave. In this event, the transmitter must leave the data line HIGH to enable the master to generate a STOP condition.

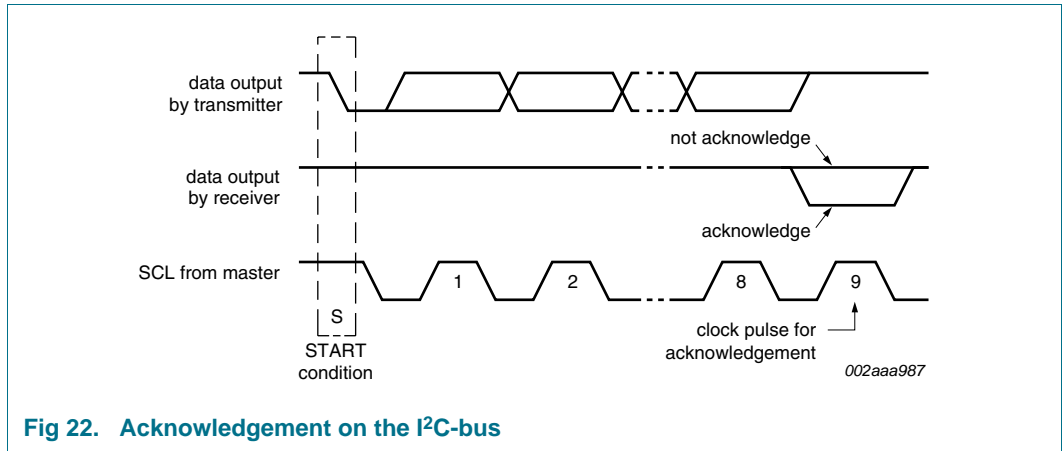

Fig 22. Acknowledgement on the I<sup>2</sup>C-bus

## 10. Application design-in information

### 10.1 Bidirectional I/O expander applications

In the 8-bit I/O expander application shown in [Figure 23](#), P00 and P01 are inputs, and P02 to P07 are outputs. When used in this configuration, during a write, the input (P00 and P01) must be written as HIGH so the external devices fully control the input ports. The desired HIGH or LOW logic levels may be written to the I/Os used as outputs (P02 to P07). During a read, the logic levels of the external devices driving the input ports (P00 and P01) and the previous written logic level to the output ports (P02 to P07) will be read.

The GPIO also has a reset line ( $\overline{\text{RESET}}$ ) that can be connected to an output pin of the microprocessor. Since the device does not have an interrupt output, changes of the I/Os can be monitored by reading the input registers. If both a  $\overline{\text{RESET}}$  and  $\overline{\text{INT}}$  are needed, use the PCA9673.

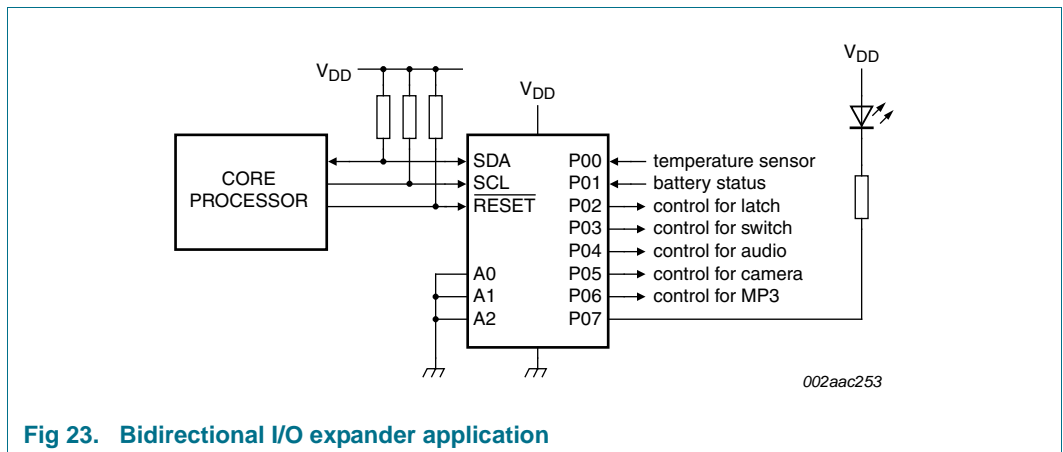

Fig 23. Bidirectional I/O expander application

### 10.2 High current-drive load applications

The GPIO has a maximum sinking current of 25 mA per bit. In applications requiring additional drive, two port pins in the same octal may be connected together to sink up to 50 mA current. Both bits must then always be turned on or off together. Up to 8 pins (one octal) can be connected together to drive 200 mA.

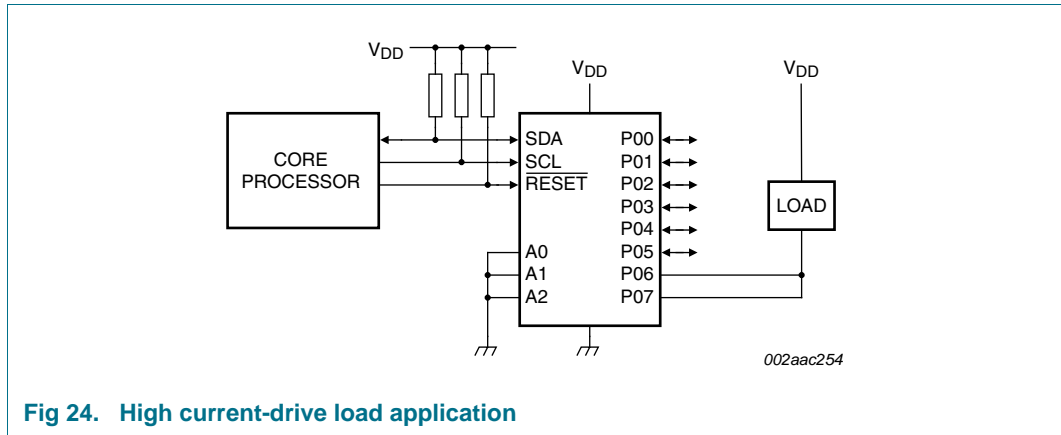

Fig 24. High current-drive load application

## 11. Limiting values

Table 4. Limiting values

In accordance with the Absolute Maximum Rating System (IEC 60134).

Symbol	Parameter	Conditions	Min	Max	Unit
V <sub>DD</sub>	supply voltage		-0.5	+6	V
I <sub>DD</sub>	supply current		-	±100	mA
I <sub>SS</sub>	ground supply current		-	±600	mA
V <sub>I</sub>	input voltage		V <sub>SS</sub> - 0.5	5.5	V
I <sub>I</sub>	input current		-	±20	mA
I <sub>O</sub>	output current		-	±50 <sup>[1]</sup>	mA
P <sub>tot</sub>	total power dissipation		-	600	mW
P/out	power dissipation per output		-	200	mW
T <sub>stg</sub>	storage temperature		-65	+150	°C
T <sub>amb</sub>	ambient temperature	operating	-40	+85	°C

[1] Total package (maximum) output current is 600 mA.

## 12. Static characteristics

**Table 5. Static characteristics**

$V_{DD} = 2.3\text{ V to }5.5\text{ V}$ ;  $V_{SS} = 0\text{ V}$ ;  $T_{amb} = -40\text{ }^{\circ}\text{C to }+85\text{ }^{\circ}\text{C}$ ; unless otherwise specified.

Symbol	Parameter	Conditions	Min	Typ	Max	Unit
<b>Supplies</b>						
$V_{DD}$	supply voltage		2.3	-	5.5	V
$I_{DD}$	supply current	operating mode; no load; $V_I = V_{DD}$ or $V_{SS}$ ; $f_{SCL} = 400\text{ kHz}$	-	200	500	$\mu\text{A}$
$I_{stb}$	standby current	standby mode; no load; $V_I = V_{DD}$ or $V_{SS}$	-	2.5	10	$\mu\text{A}$
$V_{POR}$	power-on reset voltage		[1]	1.8	2.0	V
<b>Input SCL; input/output SDA</b>						
$V_{IL}$	LOW-level input voltage		-0.5	-	+0.3 $V_{DD}$	V
$V_{IH}$	HIGH-level input voltage		0.7 $V_{DD}$	-	5.5	V
$I_{OL}$	LOW-level output current	$V_{OL} = 0.4\text{ V}$	20	-	-	mA
$I_L$	leakage current	$V_I = V_{DD}$ or $V_{SS}$	-1	-	+1	$\mu\text{A}$
$C_i$	input capacitance	$V_I = V_{SS}$	-	4	10	pF
<b>I/Os; P00 to P07 and P10 to P17</b>						
$I_{OL}$	LOW-level output current[2]	$V_{OL} = 0.5\text{ V}$ ; $V_{DD} = 2.3\text{ V}$	12	27	-	mA
		$V_{OL} = 0.5\text{ V}$ ; $V_{DD} = 3.0\text{ V}$	17	35	-	mA
		$V_{OL} = 0.5\text{ V}$ ; $V_{DD} = 4.5\text{ V}$	25	42	-	mA
$I_{OL(tot)}$	total LOW-level output current[2]	$V_{OL} = 0.5\text{ V}$ ; $V_{DD} = 4.5\text{ V}$	-	-	400	mA
$I_{OH}$	HIGH-level output current	$V_{OH} = V_{SS}$	-30	-150	-300	$\mu\text{A}$
$I_{trt(pu)}$	transient boosted pull-up current	$V_{OH} = V_{SS}$ ; see <a href="#">Figure 16</a>	-0.5	-1.0	-	mA
$C_i$	input capacitance		[3]	4	10	pF
$C_o$	output capacitance		[3]	4	10	pF
<b>Input RESET</b>						
$V_{IL}$	LOW-level input voltage		-0.5	-	+0.8	V
$V_{IH}$	HIGH-level input voltage		2	-	5.5	V
$I_{LI}$	input leakage current		-1	-	+1	$\mu\text{A}$
$C_i$	input capacitance		-	3	5	pF
<b>Inputs AD0, AD1, AD2</b>						
$V_{IL}$	LOW-level input voltage		-0.5	-	+0.3 $V_{DD}$	V
$V_{IH}$	HIGH-level input voltage		0.7 $V_{DD}$	-	5.5	V
$I_{LI}$	input leakage current		-1	-	+1	$\mu\text{A}$
$C_i$	input capacitance		-	3	5	pF

[1] The power-on reset circuit resets the I<sup>2</sup>C-bus logic with  $V_{DD} < V_{POR}$  and set all I/Os to logic 1 (with current source to  $V_{DD}$ ).

[2] Each bit must be limited to a maximum of 25 mA and the total package limited to 400 mA due to internal busing limits.

[3] The value is not tested, but verified on sampling basis.

### 13. Dynamic characteristics

**Table 6. Dynamic characteristics**
 $V_{DD} = 2.3\text{ V to }5.5\text{ V}; V_{SS} = 0\text{ V}; T_{amb} = -40\text{ }^{\circ}\text{C to }+85\text{ }^{\circ}\text{C};$  unless otherwise specified.

Symbol	Parameter	Conditions	Standard-mode I <sup>2</sup> C-bus		Fast-mode I <sup>2</sup> C-bus		Fast-mode Plus I <sup>2</sup> C-bus		Unit
			Min	Max	Min	Max	Min	Max	
f <sub>SCL</sub>	SCL clock frequency		0	100	0	400	0	1000	kHz
t <sub>BUF</sub>	bus free time between a STOP and START condition		4.7	-	1.3	-	0.5	-	μs
t <sub>HD;STA</sub>	hold time (repeated) START condition		4.0	-	0.6	-	0.26	-	μs
t <sub>SU;STA</sub>	set-up time for a repeated START condition		4.7	-	0.6	-	0.26	-	μs
t <sub>SU;STO</sub>	set-up time for STOP condition		4.0	-	0.6	-	0.26	-	μs
t <sub>HD;DAT</sub>	data hold time		0	-	0	-	0	-	ns
t <sub>VD;ACK</sub>	data valid acknowledge time [1]		0.3	3.45	0.1	0.9	0.05	0.45	μs
t <sub>VD;DAT</sub>	data valid time [2]		300	-	50	-	50	450	ns
t <sub>SU;DAT</sub>	data set-up time		250	-	100	-	50	-	ns
t <sub>LOW</sub>	LOW period of the SCL clock		4.7	-	1.3	-	0.5	-	μs
t <sub>HIGH</sub>	HIGH period of the SCL clock		4.0	-	0.6	-	0.26	-	μs
t <sub>f</sub>	fall time of both SDA and SCL signals	[4][5]	-	300	20 + 0.1C <sub>b</sub> [3]	300	-	120	ns
t <sub>r</sub>	rise time of both SDA and SCL signals		-	1000	20 + 0.1C <sub>b</sub> [3]	300	-	120	ns
t <sub>SP</sub>	pulse width of spikes that must be suppressed by the input filter [6]		-	50	-	50	-	50	ns
<b>Port timing; C<sub>L</sub> ≤ 100 pF (see Figure 17 and Figure 16)</b>									
t <sub>v(Q)</sub>	data output valid time		-	4	-	4	-	4	μs
t <sub>su(D)</sub>	data input set-up time		0	-	0	-	0	-	μs
t <sub>h(D)</sub>	data input hold time		4	-	4	-	4	-	μs
<b>Reset timing (see Figure 26)</b>									
t <sub>w(rst)</sub>	reset pulse width		4	-	4	-	4	-	ns
t <sub>rec(rst)</sub>	reset recovery time		0	-	0	-	0	-	ns
t <sub>rst</sub>	reset time		100	-	100	-	100	-	ns

[1] t<sub>VD;ACK</sub> = time for Acknowledgement signal from SCL LOW to SDA (out) LOW.

[2] t<sub>VD;DAT</sub> = minimum time for SDA data out to be valid following SCL LOW.

[3] C<sub>b</sub> = total capacitance of one bus line in pF.

[4] A master device must internally provide a hold time of at least 300 ns for the SDA signal (refer to the V<sub>IL</sub> of the SCL signal) in order to bridge the undefined region SCL's falling edge.

- [5] The maximum  $t_r$  for the SDA and SCL bus lines is specified at 300 ns. The maximum fall time for the SDA output stage  $t_f$  is specified at 250 ns. This allows series protection resistors to be connected between the SDA and the SCL pins and the SDA/SCL bus lines without exceeding the maximum specified  $t_r$ .
- [6] Input filters on the SDA and SCL inputs suppress noise spikes less than 50 ns.

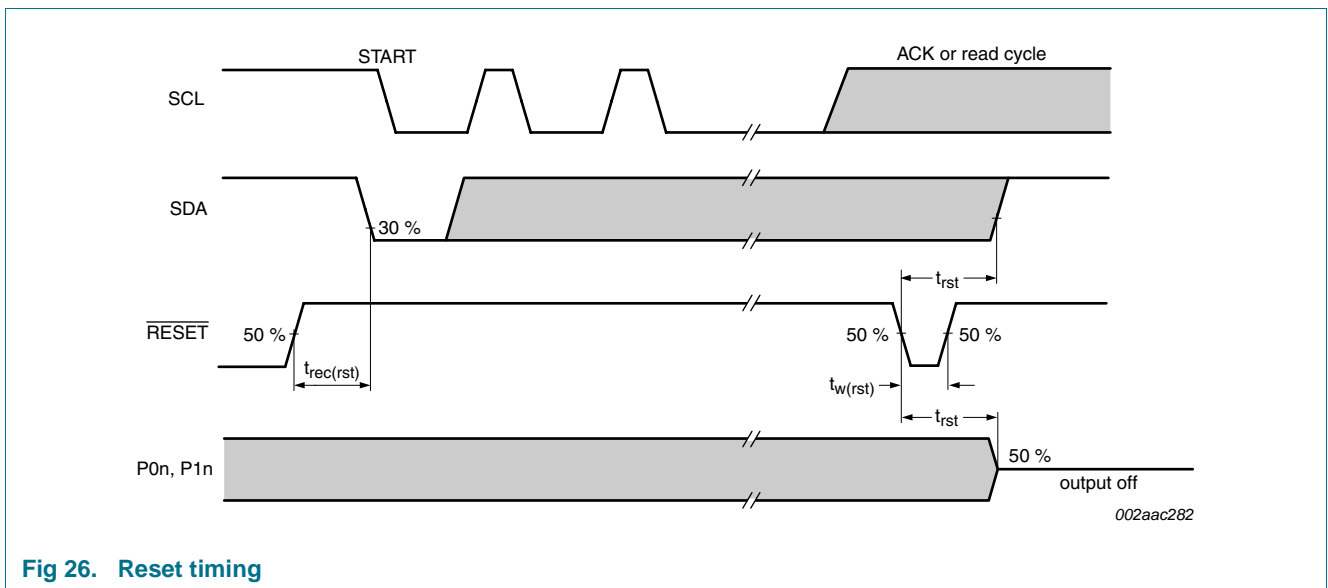
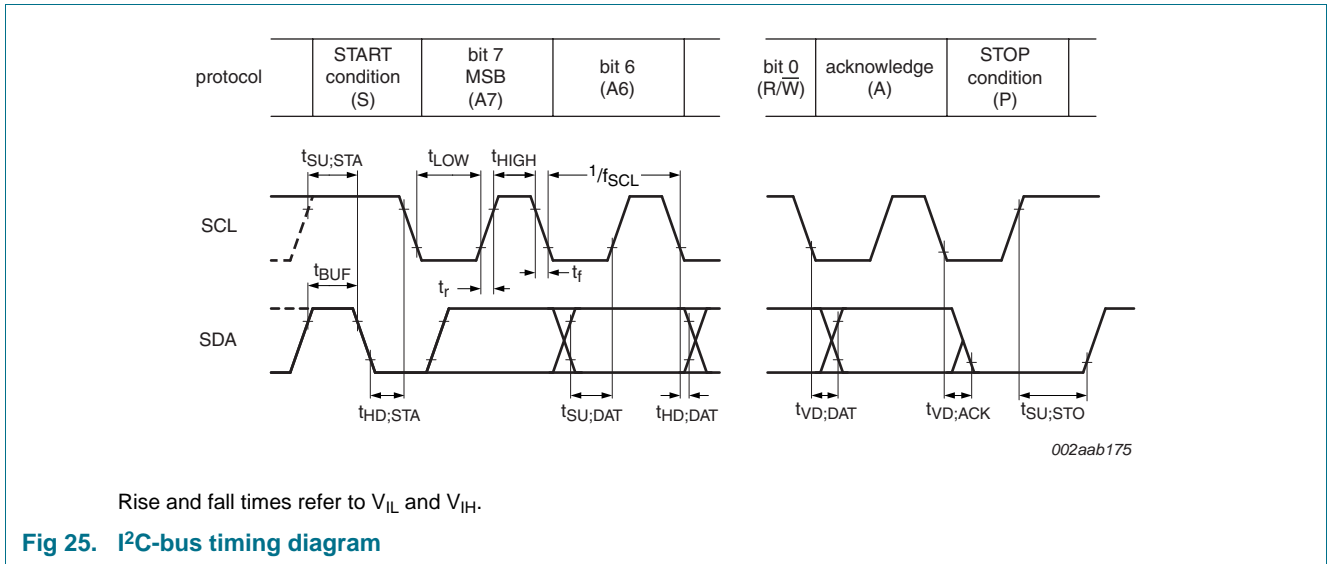

14. Package outline

SO24: plastic small outline package; 24 leads; body width 7.5 mm

SOT137-1

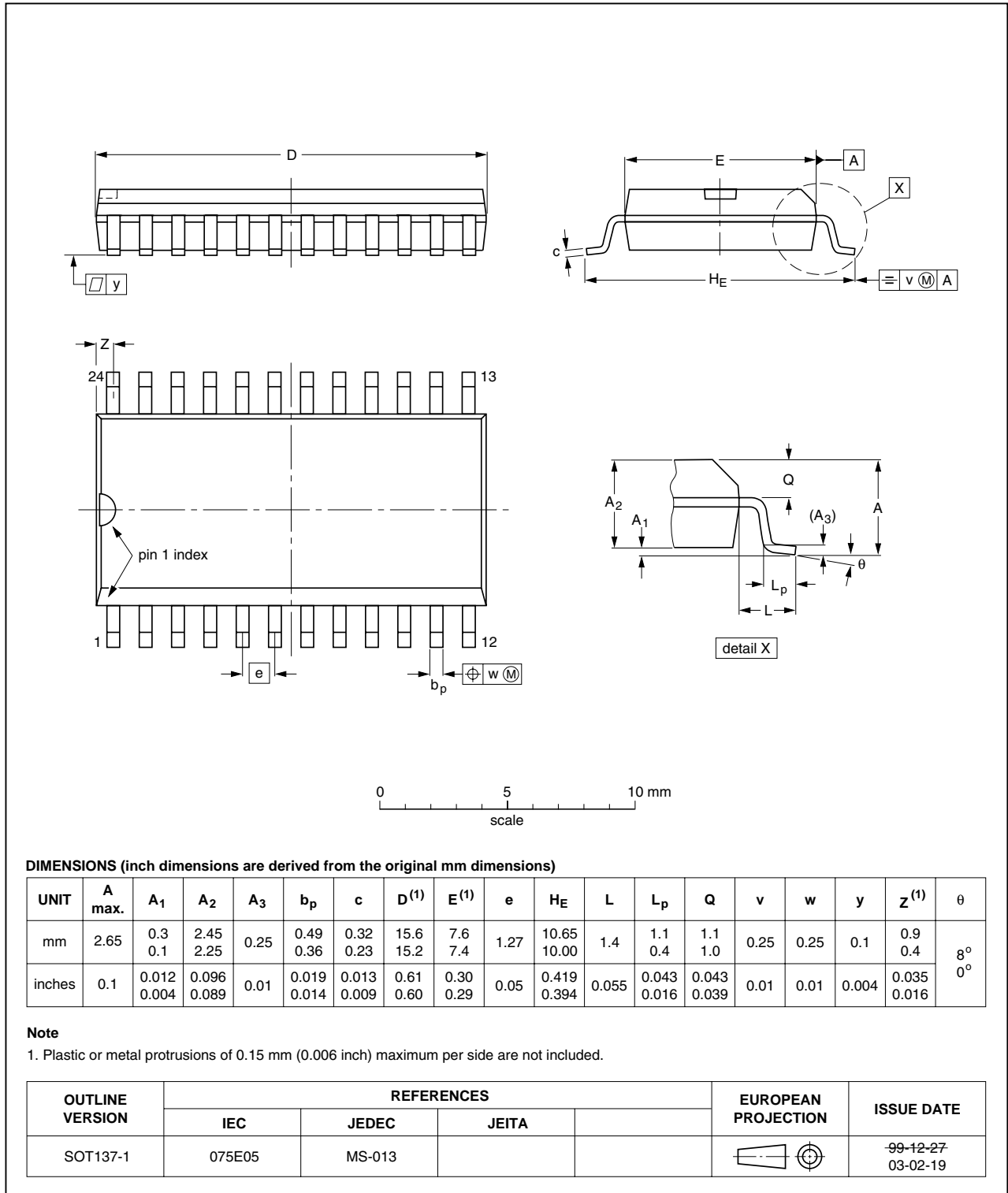

Fig 27. Package outline SOT137-1 (SO24)

SSOP24: plastic shrink small outline package; 24 leads; body width 5.3 mm

SOT340-1

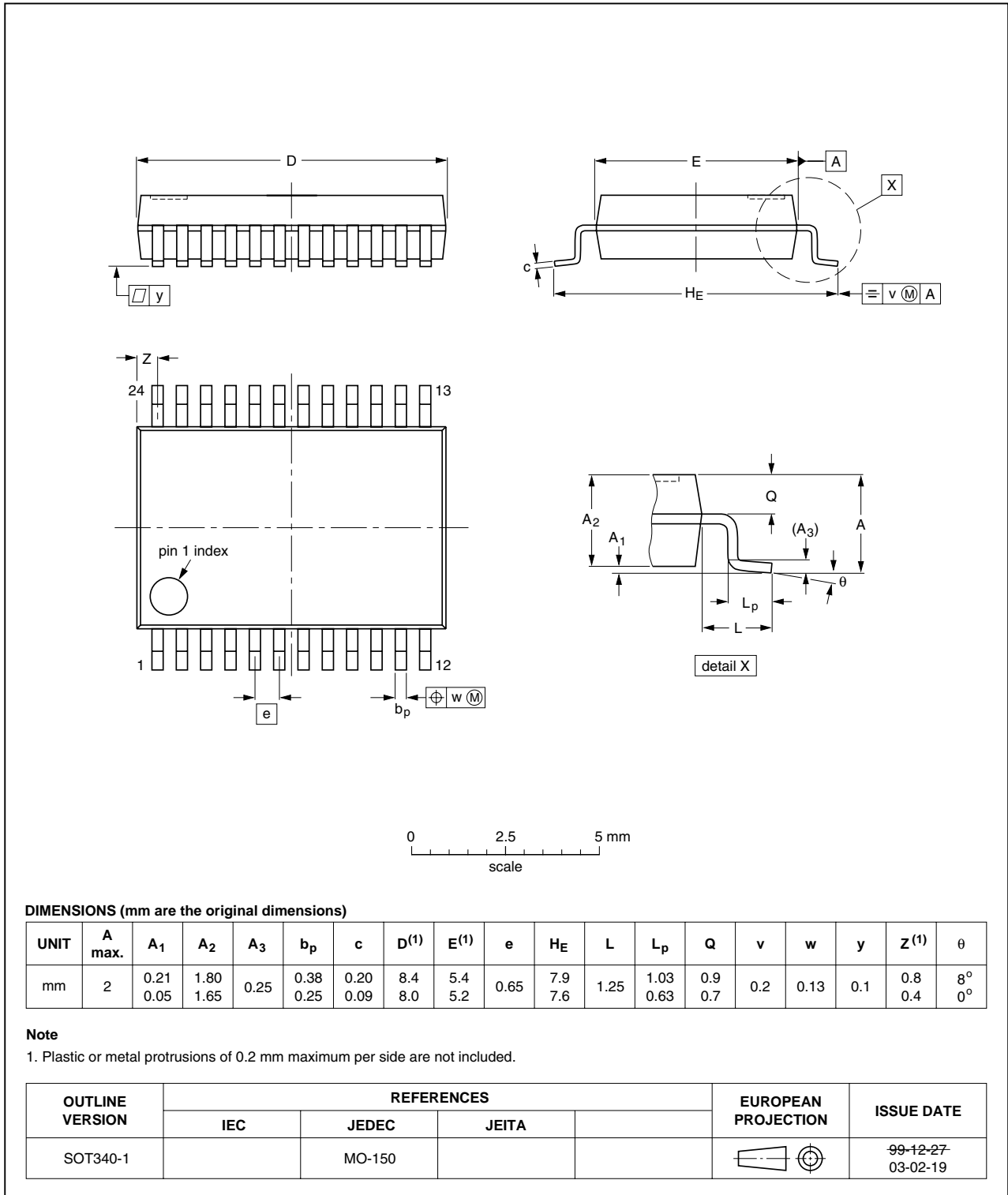

Fig 28. Package outline SOT340-1 (SSOP24)



SSOP24: plastic shrink small outline package; 24 leads; body width 3.9 mm; lead pitch 0.635 mm SOT556-1

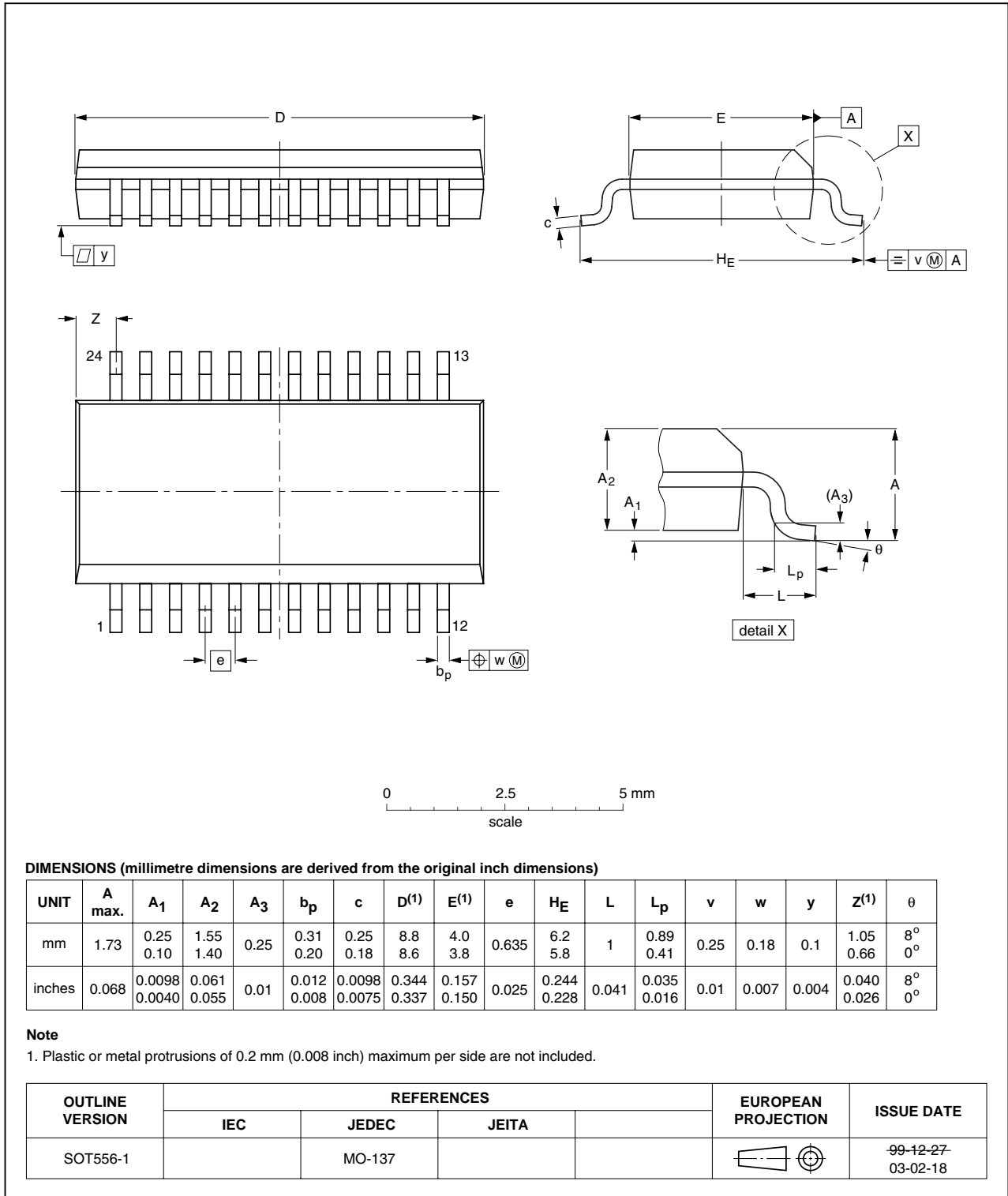

Fig 29. Package outline SOT556-1 (SSOP24)

TSSOP24: plastic thin shrink small outline package; 24 leads; body width 4.4 mm

SOT355-1

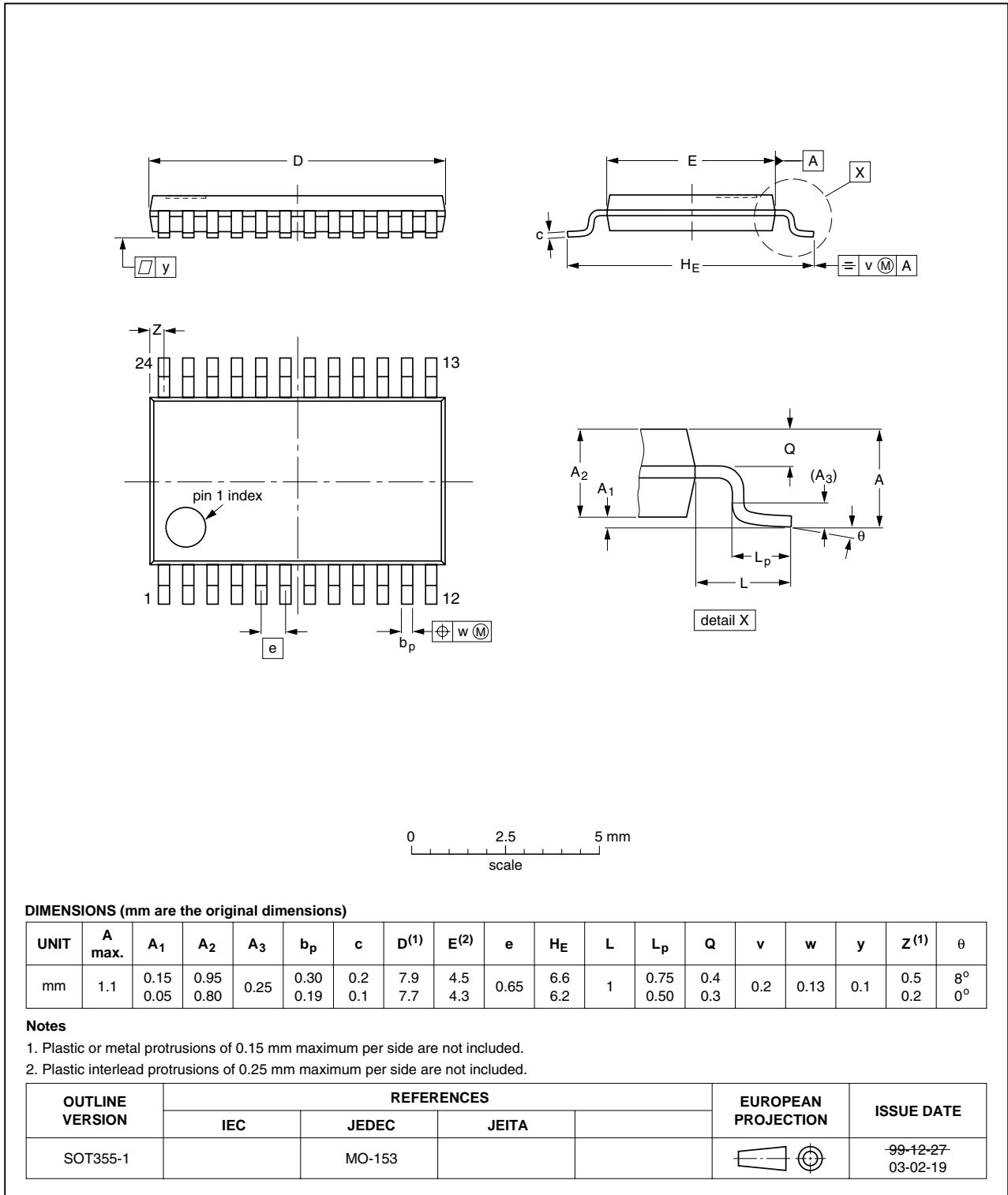

Fig 30. Package outline SOT355-1 (TSSOP24)

DHVQFN24: plastic dual in-line compatible thermal enhanced very thin quad flat package; no leads; 24 terminals; body 3.5 x 5.5 x 0.85 mm

SOT815-1

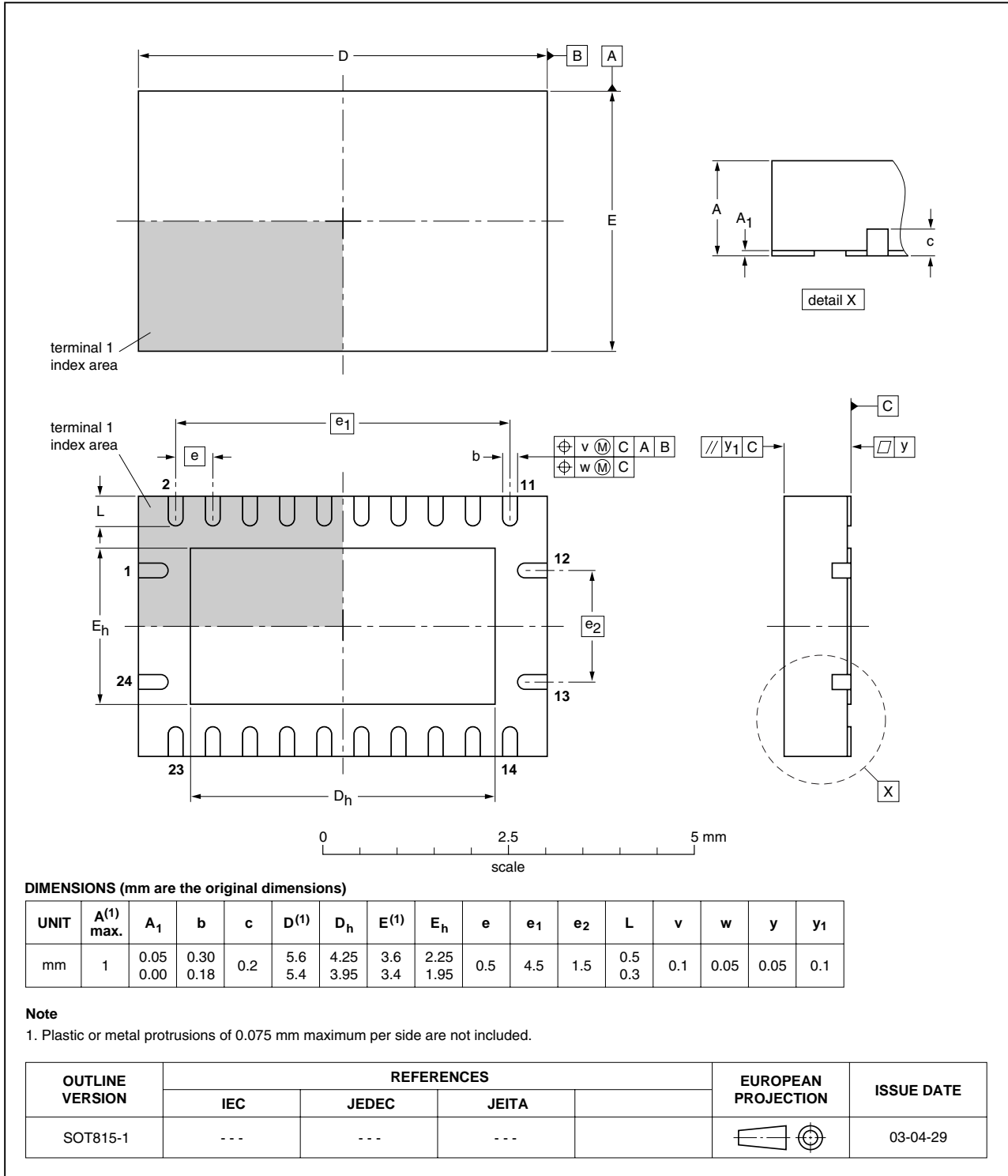

Fig 31. Package outline SOT815-1 (DHVQFN24)

HVQFN24: plastic thermal enhanced very thin quad flat package; no leads; 24 terminals; body 4 x 4 x 0.85 mm

SOT616-1

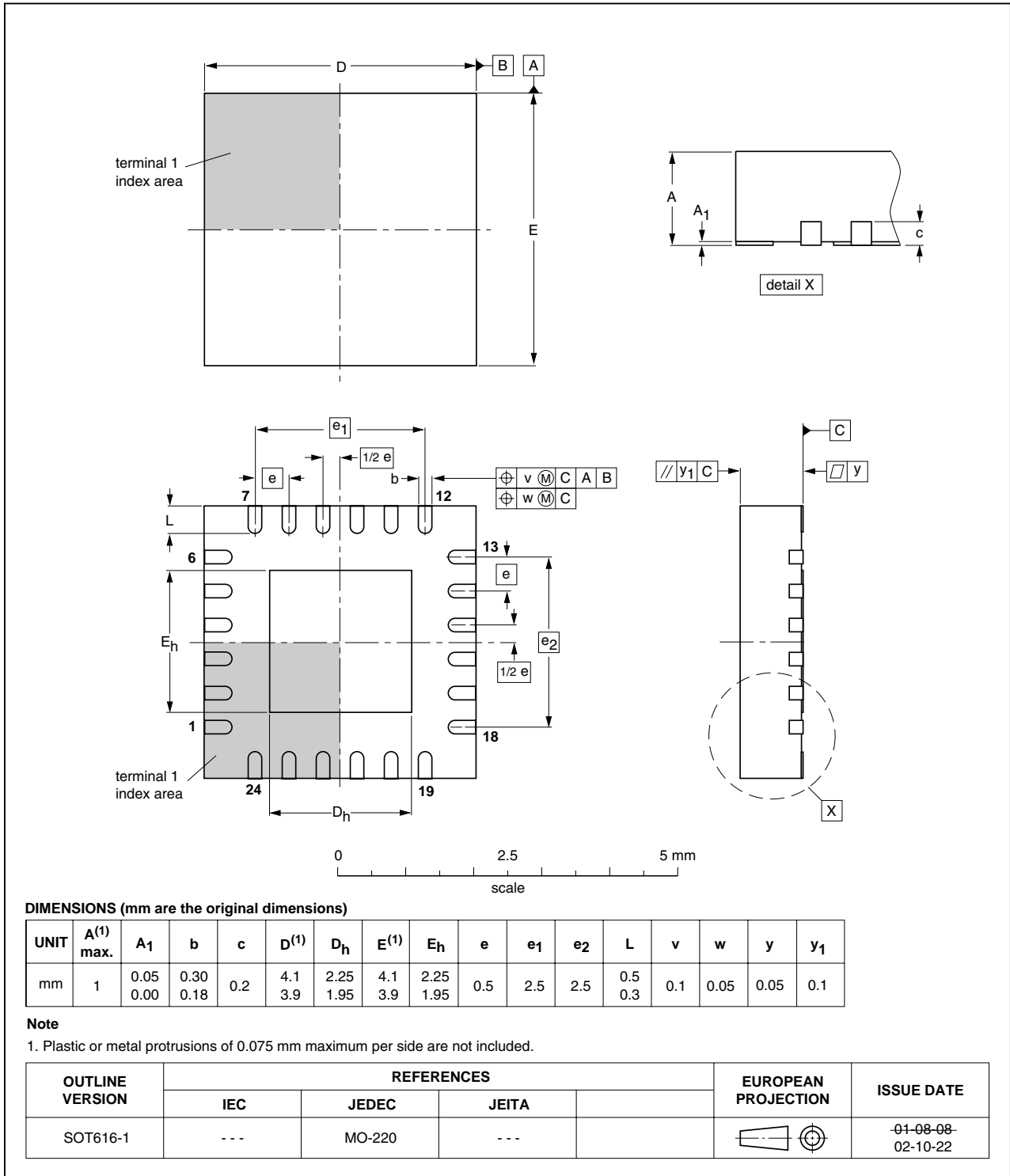

Fig 32. Package outline SOT616-1 (HVQFN24)

## 15. Handling information

All input and output pins are protected against ElectroStatic Discharge (ESD) under normal handling. When handling ensure that the appropriate precautions are taken as described in *JESD625-A* or equivalent standards.

## 16. Soldering of SMD packages

This text provides a very brief insight into a complex technology. A more in-depth account of soldering ICs can be found in Application Note *AN10365 "Surface mount reflow soldering description"*.

### 16.1 Introduction to soldering

Soldering is one of the most common methods through which packages are attached to Printed Circuit Boards (PCBs), to form electrical circuits. The soldered joint provides both the mechanical and the electrical connection. There is no single soldering method that is ideal for all IC packages. Wave soldering is often preferred when through-hole and Surface Mount Devices (SMDs) are mixed on one printed wiring board; however, it is not suitable for fine pitch SMDs. Reflow soldering is ideal for the small pitches and high densities that come with increased miniaturization.

### 16.2 Wave and reflow soldering

Wave soldering is a joining technology in which the joints are made by solder coming from a standing wave of liquid solder. The wave soldering process is suitable for the following:

- Through-hole components
- Leaded or leadless SMDs, which are glued to the surface of the printed circuit board

Not all SMDs can be wave soldered. Packages with solder balls, and some leadless packages which have solder lands underneath the body, cannot be wave soldered. Also, leaded SMDs with leads having a pitch smaller than ~0.6 mm cannot be wave soldered, due to an increased probability of bridging.

The reflow soldering process involves applying solder paste to a board, followed by component placement and exposure to a temperature profile. Leaded packages, packages with solder balls, and leadless packages are all reflow solderable.

Key characteristics in both wave and reflow soldering are:

- Board specifications, including the board finish, solder masks and vias
- Package footprints, including solder thieves and orientation
- The moisture sensitivity level of the packages
- Package placement
- Inspection and repair
- Lead-free soldering versus SnPb soldering

### 16.3 Wave soldering

Key characteristics in wave soldering are:

- Process issues, such as application of adhesive and flux, clinching of leads, board transport, the solder wave parameters, and the time during which components are exposed to the wave
- Solder bath specifications, including temperature and impurities

### 16.4 Reflow soldering

Key characteristics in reflow soldering are:

- Lead-free versus SnPb soldering; note that a lead-free reflow process usually leads to higher minimum peak temperatures (see [Figure 33](#)) than a SnPb process, thus reducing the process window
- Solder paste printing issues including smearing, release, and adjusting the process window for a mix of large and small components on one board
- Reflow temperature profile; this profile includes preheat, reflow (in which the board is heated to the peak temperature) and cooling down. It is imperative that the peak temperature is high enough for the solder to make reliable solder joints (a solder paste characteristic). In addition, the peak temperature must be low enough that the packages and/or boards are not damaged. The peak temperature of the package depends on package thickness and volume and is classified in accordance with [Table 7](#) and [8](#)

**Table 7. SnPb eutectic process (from J-STD-020C)**

Package thickness (mm)	Package reflow temperature (°C)	
	Volume (mm <sup>3</sup> )	
	< 350	≥ 350
< 2.5	235	220
≥ 2.5	220	220

**Table 8. Lead-free process (from J-STD-020C)**

Package thickness (mm)	Package reflow temperature (°C)		
	Volume (mm <sup>3</sup> )		
	< 350	350 to 2000	> 2000
< 1.6	260	260	260
1.6 to 2.5	260	250	245
> 2.5	250	245	245

Moisture sensitivity precautions, as indicated on the packing, must be respected at all times.

Studies have shown that small packages reach higher temperatures during reflow soldering, see [Figure 33](#).

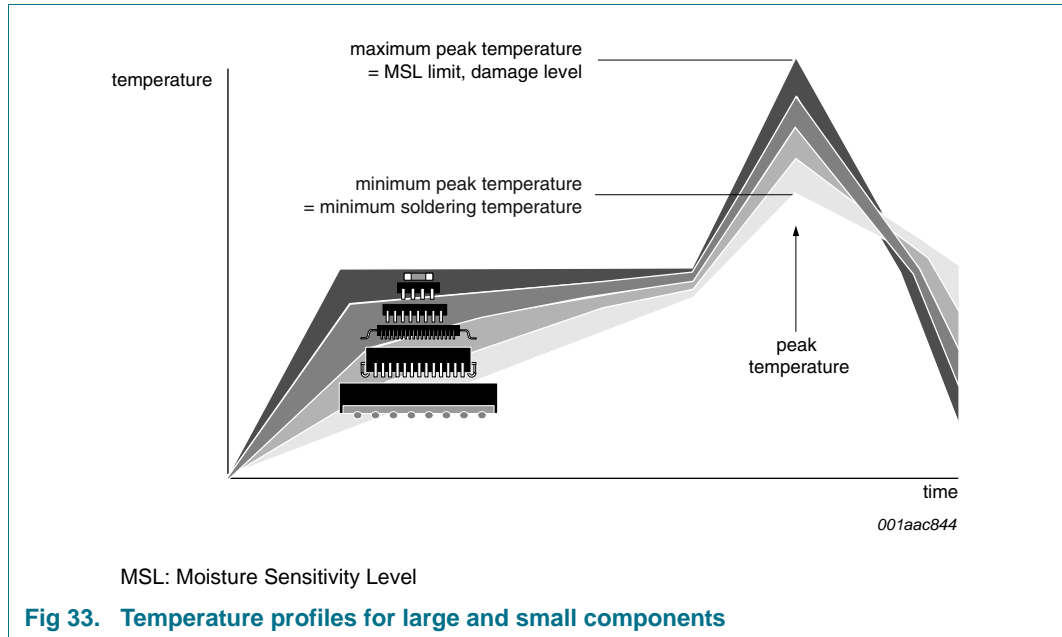

For further information on temperature profiles, refer to Application Note AN10365 “Surface mount reflow soldering description”.

## 17. Abbreviations

**Table 9. Abbreviations**

Acronym	Description
CDM	Charged Device Model
CMOS	Complementary Metal Oxide Semiconductor
ESD	ElectroStatic Discharge
GPIO	General Purpose Input/Output
HBM	Human Body Model
I <sup>2</sup> C-bus	Inter-Integrated Circuit bus
I/O	Input/Output
IC	Integrated Circuit
ID	Identification
LED	Light Emitting Diode
LSB	Least Significant Bit
MM	Machine Model
MSB	Most Significant Bit
PLC	Programmable Logic Controller
PWM	Pulse Width Modulation
RAID	Redundant Array of Independent Disks
SMBus	System Management Bus

## 18. Revision history

Table 10. Revision history

Document ID	Release date	Data sheet status	Change notice	Supersedes
PCA9671 v.2	20100729	Product data sheet	-	PCA9671 v.1
Modifications:	<ul style="list-style-type: none"><li>• <a href="#">Table 5 “Static characteristics”</a>, sub-section “Input RESET” is corrected by removing I<sub>OH</sub> specification</li></ul>			
PCA9671 v.1	20061220	Product data sheet	-	-



## 19. Legal information

### 19.1 Data sheet status

Document status <sup>[1][2]</sup>	Product status <sup>[3]</sup>	Definition
Objective [short] data sheet	Development	This document contains data from the objective specification for product development.
Preliminary [short] data sheet	Qualification	This document contains data from the preliminary specification.
Product [short] data sheet	Production	This document contains the product specification.

[1] Please consult the most recently issued document before initiating or completing a design.

[2] The term 'short data sheet' is explained in section "Definitions".

[3] The product status of device(s) described in this document may have changed since this document was published and may differ in case of multiple devices. The latest product status information is available on the Internet at URL <http://www.nxp.com>.

### 19.2 Definitions

**Draft** — The document is a draft version only. The content is still under internal review and subject to formal approval, which may result in modifications or additions. NXP Semiconductors does not give any representations or warranties as to the accuracy or completeness of information included herein and shall have no liability for the consequences of use of such information.

**Short data sheet** — A short data sheet is an extract from a full data sheet with the same product type number(s) and title. A short data sheet is intended for quick reference only and should not be relied upon to contain detailed and full information. For detailed and full information see the relevant full data sheet, which is available on request via the local NXP Semiconductors sales office. In case of any inconsistency or conflict with the short data sheet, the full data sheet shall prevail.

**Product specification** — The information and data provided in a Product data sheet shall define the specification of the product as agreed between NXP Semiconductors and its customer, unless NXP Semiconductors and customer have explicitly agreed otherwise in writing. In no event however, shall an agreement be valid in which the NXP Semiconductors product is deemed to offer functions and qualities beyond those described in the Product data sheet.

### 19.3 Disclaimers

**Limited warranty and liability** — Information in this document is believed to be accurate and reliable. However, NXP Semiconductors does not give any representations or warranties, expressed or implied, as to the accuracy or completeness of such information and shall have no liability for the consequences of use of such information.

In no event shall NXP Semiconductors be liable for any indirect, incidental, punitive, special or consequential damages (including - without limitation - lost profits, lost savings, business interruption, costs related to the removal or replacement of any products or rework charges) whether or not such damages are based on tort (including negligence), warranty, breach of contract or any other legal theory.

Notwithstanding any damages that customer might incur for any reason whatsoever, NXP Semiconductors' aggregate and cumulative liability towards customer for the products described herein shall be limited in accordance with the *Terms and conditions of commercial sale* of NXP Semiconductors.

**Right to make changes** — NXP Semiconductors reserves the right to make changes to information published in this document, including without limitation specifications and product descriptions, at any time and without notice. This document supersedes and replaces all information supplied prior to the publication hereof.

**Suitability for use** — NXP Semiconductors products are not designed, authorized or warranted to be suitable for use in life support, life-critical or safety-critical systems or equipment, nor in applications where failure or

malfunction of an NXP Semiconductors product can reasonably be expected to result in personal injury, death or severe property or environmental damage. NXP Semiconductors accepts no liability for inclusion and/or use of NXP Semiconductors products in such equipment or applications and therefore such inclusion and/or use is at the customer's own risk.

**Applications** — Applications that are described herein for any of these products are for illustrative purposes only. NXP Semiconductors makes no representation or warranty that such applications will be suitable for the specified use without further testing or modification.

Customers are responsible for the design and operation of their applications and products using NXP Semiconductors products, and NXP Semiconductors accepts no liability for any assistance with applications or customer product design. It is customer's sole responsibility to determine whether the NXP Semiconductors product is suitable and fit for the customer's applications and products planned, as well as for the planned application and use of customer's third party customer(s). Customers should provide appropriate design and operating safeguards to minimize the risks associated with their applications and products.

NXP Semiconductors does not accept any liability related to any default, damage, costs or problem which is based on any weakness or default in the customer's applications or products, or the application or use by customer's third party customer(s). Customer is responsible for doing all necessary testing for the customer's applications and products using NXP Semiconductors products in order to avoid a default of the applications and the products or of the application or use by customer's third party customer(s). NXP does not accept any liability in this respect.

**Limiting values** — Stress above one or more limiting values (as defined in the Absolute Maximum Ratings System of IEC 60134) will cause permanent damage to the device. Limiting values are stress ratings only and (proper) operation of the device at these or any other conditions above those given in the Recommended operating conditions section (if present) or the Characteristics sections of this document is not warranted. Constant or repeated exposure to limiting values will permanently and irreversibly affect the quality and reliability of the device.

**Terms and conditions of commercial sale** — NXP Semiconductors products are sold subject to the general terms and conditions of commercial sale, as published at <http://www.nxp.com/profile/terms>, unless otherwise agreed in a valid written individual agreement. In case an individual agreement is concluded only the terms and conditions of the respective agreement shall apply. NXP Semiconductors hereby expressly objects to applying the customer's general terms and conditions with regard to the purchase of NXP Semiconductors products by customer.

**No offer to sell or license** — Nothing in this document may be interpreted or construed as an offer to sell products that is open for acceptance or the grant, conveyance or implication of any license under any copyrights, patents or other industrial or intellectual property rights.

**Export control** — This document as well as the item(s) described herein may be subject to export control regulations. Export might require a prior authorization from national authorities.

**Non-automotive qualified products** — Unless this data sheet expressly states that this specific NXP Semiconductors product is automotive qualified, the product is not suitable for automotive use. It is neither qualified nor tested in accordance with automotive testing or application requirements. NXP Semiconductors accepts no liability for inclusion and/or use of non-automotive qualified products in automotive equipment or applications.

In the event that customer uses the product for design-in and use in automotive applications to automotive specifications and standards, customer (a) shall use the product without NXP Semiconductors' warranty of the product for such automotive applications, use and specifications, and (b) whenever customer uses the product for automotive applications beyond NXP Semiconductors' specifications such use shall be solely at customer's

own risk, and (c) customer fully indemnifies NXP Semiconductors for any liability, damages or failed product claims resulting from customer design and use of the product for automotive applications beyond NXP Semiconductors' standard warranty and NXP Semiconductors' product specifications.

## 19.4 Trademarks

Notice: All referenced brands, product names, service names and trademarks are the property of their respective owners.

**I<sup>2</sup>C-bus** — logo is a trademark of NXP B.V.

## 20. Contact information

For more information, please visit: <http://www.nxp.com>

For sales office addresses, please send an email to: [salesaddresses@nxp.com](mailto:salesaddresses@nxp.com)

## 21. Contents

<b>1</b>	<b>General description</b> .....	<b>1</b>	<b>19.4</b>	<b>Trademarks</b> .....	<b>34</b>
<b>2</b>	<b>Features and benefits</b> .....	<b>1</b>	<b>20</b>	<b>Contact information</b> .....	<b>34</b>
<b>3</b>	<b>Applications</b> .....	<b>2</b>	<b>21</b>	<b>Contents</b> .....	<b>35</b>
<b>4</b>	<b>Ordering information</b> .....	<b>2</b>			
<b>5</b>	<b>Block diagram</b> .....	<b>3</b>			
<b>6</b>	<b>Pinning information</b> .....	<b>4</b>			
6.1	Pinning .....	4			
6.2	Pin description .....	5			
<b>7</b>	<b>Functional description</b> .....	<b>6</b>			
7.1	Device address .....	6			
7.1.1	Address maps .....	7			
7.2	Software Reset call, and device ID addresses ..	9			
7.2.1	Software Reset .....	9			
7.2.2	Device ID (PCA9671 ID field) .....	10			
<b>8</b>	<b>I/O programming</b> .....	<b>12</b>			
8.1	Quasi-bidirectional I/O architecture .....	12			
8.2	Writing to the port (Output mode) .....	12			
8.3	Reading from a port (Input mode) .....	13			
8.4	Power-on reset .....	16			
8.5	RESET input .....	16			
<b>9</b>	<b>Characteristics of the I<sup>2</sup>C-bus</b> .....	<b>16</b>			
9.1	Bit transfer .....	16			
9.1.1	START and STOP conditions .....	16			
9.2	System configuration .....	17			
9.3	Acknowledge .....	17			
<b>10</b>	<b>Application design-in information</b> .....	<b>18</b>			
10.1	Bidirectional I/O expander applications .....	18			
10.2	High current-drive load applications .....	19			
<b>11</b>	<b>Limiting values</b> .....	<b>19</b>			
<b>12</b>	<b>Static characteristics</b> .....	<b>20</b>			
<b>13</b>	<b>Dynamic characteristics</b> .....	<b>21</b>			
<b>14</b>	<b>Package outline</b> .....	<b>23</b>			
<b>15</b>	<b>Handling information</b> .....	<b>29</b>			
<b>16</b>	<b>Soldering of SMD packages</b> .....	<b>29</b>			
16.1	Introduction to soldering .....	29			
16.2	Wave and reflow soldering .....	29			
16.3	Wave soldering .....	29			
16.4	Reflow soldering .....	30			
<b>17</b>	<b>Abbreviations</b> .....	<b>31</b>			
<b>18</b>	<b>Revision history</b> .....	<b>32</b>			
<b>19</b>	<b>Legal information</b> .....	<b>33</b>			
19.1	Data sheet status .....	33			
19.2	Definitions .....	33			
19.3	Disclaimers .....	33			

Please be aware that important notices concerning this document and the product(s) described herein, have been included in section 'Legal information'.

© NXP B.V. 2010.

All rights reserved.

For more information, please visit: <http://www.nxp.com>

For sales office addresses, please send an email to: [salesaddresses@nxp.com](mailto:salesaddresses@nxp.com)

Date of release: 29 July 2010

Document identifier: PCA9671