

# White LED Step-Up Converter in SC70 and ThinSOT

## FEATURES

- Inherently Matched LED Current
- High Efficiency: 84% Typical
- Drives Up to Four LEDs from a 3.2V Supply
- Drives Up to Six LEDs from a 5V Supply
- 36V Rugged Bipolar Switch
- Fast 1.2MHz Switching Frequency
- Uses Tiny 1mm Tall Inductors
- Requires Only 0.22 $\mu$ F Output Capacitor
- Low Profile SC70 and ThinSOT™ Packaging

## APPLICATIONS

- Cellular Phones
- PDAs, Handheld Computers
- Digital Cameras
- MP3 Players
- GPS Receivers

## DESCRIPTION

The LT<sup>®</sup>1937 is a step-up DC/DC converter specifically designed to drive white LEDs with a constant current. The device can drive two, three or four LEDs in series from a Li-Ion cell. Series connection of the LEDs provides identical LED currents resulting in uniform brightness and eliminating the need for ballast resistors. The LT1937 switches at 1.2MHz, allowing the use of tiny external components. The output capacitor can be as small as 0.22 $\mu$ F, saving space and cost versus alternative solutions. A low 95mV feedback voltage minimizes power loss in the current setting resistor for better efficiency.

The LT1937 is available in low profile SC70 and ThinSOT packages.

LT, LTC and LT are registered trademarks of Linear Technology Corporation. ThinSOT is a trademark of Linear Technology Corporation.

## TYPICAL APPLICATION

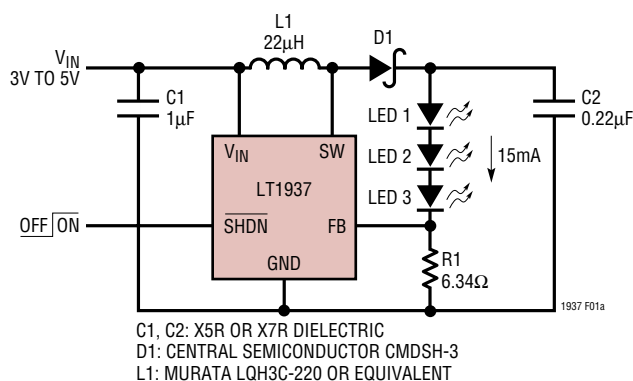
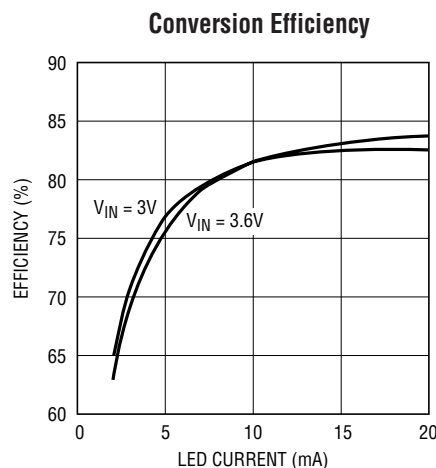

Figure 1. Li-Ion Powered Driver for Three White LEDs



1937 TA01b

**ABSOLUTE MAXIMUM RATINGS** (Note 1)

Input Voltage ( $V_{IN}$ ) .....	10V	Extended Commercial
SW Voltage .....	36V	Operating Temperature Range (Note 2) ...
FB Voltage .....	10V	–40°C to 85°C
SHDN Voltage .....	10V	Maximum Junction Temperature .....
		125°C
		Storage Temperature Range .....
		–65°C to 150°C
		Lead Temperature (Soldering, 10 sec) .....
		300°C

**PACKAGE/ORDER INFORMATION**

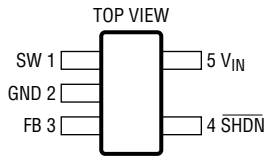
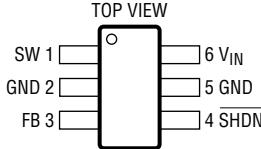
 <p>S5 PACKAGE 5-LEAD PLASTIC TSOT-23</p> <p><math>T_{JMAX} = 125^{\circ}C</math>, <math>\theta_{JA} = 256^{\circ}C/W</math> IN FREE AIR <math>\theta_{JA} = 120^{\circ}C</math> ON BOARD OVER GROUND PLANE</p>	ORDER PART NUMBER	 <p>SC6 PACKAGE 6-LEAD PLASTIC SC70</p> <p><math>T_{JMAX} = 125^{\circ}C</math>, <math>\theta_{JA} = 256^{\circ}C/W</math> IN FREE AIR <math>\theta_{JA} = 150^{\circ}C</math> ON BOARD OVER GROUND PLANE</p>	ORDER PART NUMBER
	LT1937ES5		LT1937ESC6
	S5 PART MARKING		SC6 PART MARKING
	LTYN		LAAB

Consult LTC Marketing for parts specified with wider operating temperature ranges.

**ELECTRICAL CHARACTERISTICS**  $T_A = 25^{\circ}C$ ,  $V_{IN} = 3V$ ,  $V_{SHDN} = 3V$ , unless otherwise noted.

PARAMETER	CONDITIONS	MIN	TYP	MAX	UNITS
Minimum Operating Voltage		2.5			V
Maximum Operating Voltage				10	V
Feedback Voltage	$I_{SW} = 100mA$ , Duty Cycle = 66%	86	95	104	mV
FB Pin Bias Current		10	45	100	nA
Supply Current	$\overline{SHDN} = 0V$		1.9	2.5	mA
			0.1	1.0	$\mu A$
Switching Frequency		0.8	1.2	1.6	MHz
Maximum Duty Cycle		85	90		%
Switch Current Limit			320		mA
Switch $V_{CESAT}$	$I_{SW} = 250mA$		350		mV
Switch Leakage Current	$V_{SW} = 5V$		0.01	5	$\mu A$
SHDN Voltage High		1.5			V
SHDN Voltage Low				0.4	V
SHDN Pin Bias Current			65		$\mu A$

**Note 1:** Absolute Maximum Ratings are those values beyond which the life of the device may be impaired.

**Note 2:** The LT1937E is guaranteed to meet specifications from 0°C to 70°C. Specifications over the –40°C to 85°C operating temperature range are assured by design, characterization and correlation with statistical process controls.

# TYPICAL PERFORMANCE CHARACTERISTICS

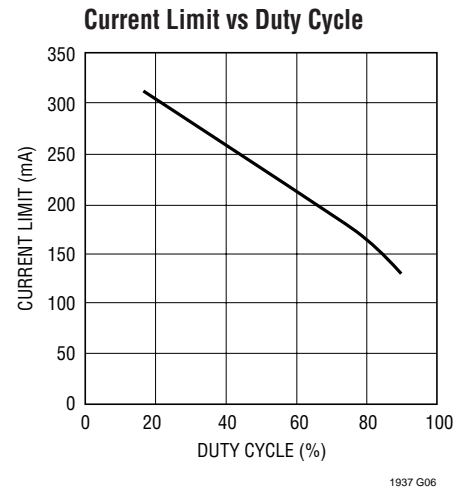
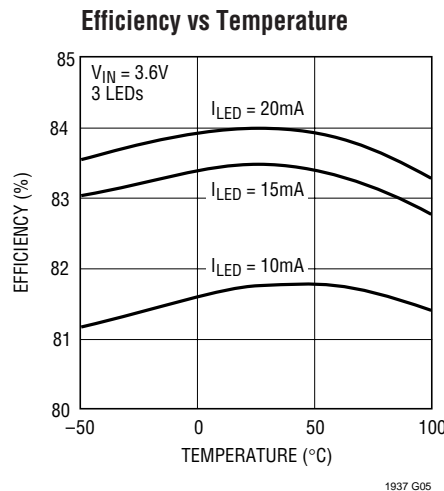
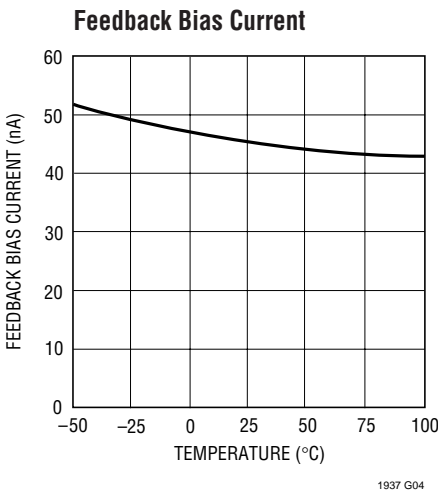
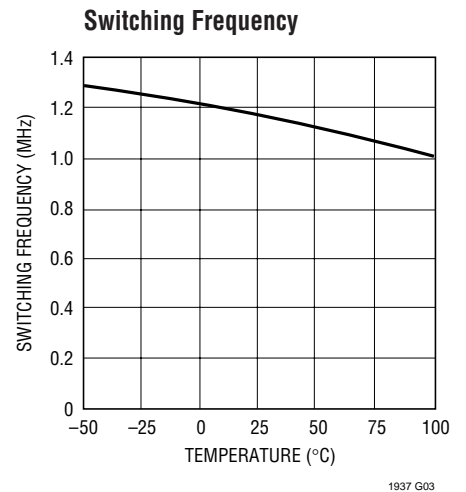
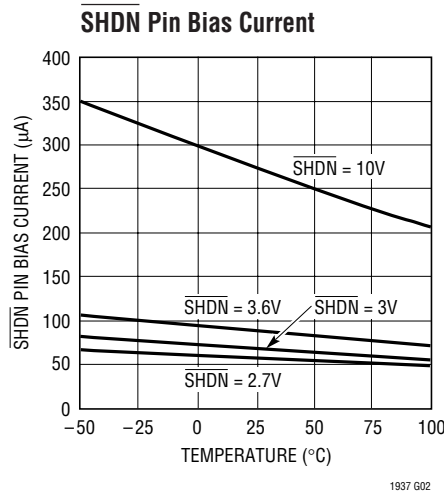
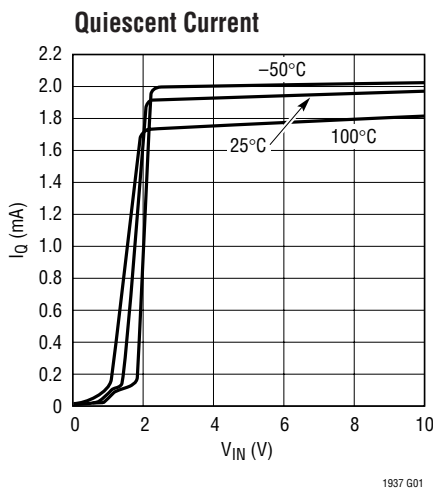

## PIN FUNCTIONS

**SW (Pin 1):** Switch Pin. Connect inductor/diode here. Minimize trace area at this pin to reduce EMI.

**GND (Pin 2):** Ground Pin. Connect directly to local ground plane.

**FB (Pin 3):** Feedback Pin. Reference voltage is 95mV. Connect cathode of lowest LED and resistor here. Calculate resistor value according to the formula:

$$R_{FB} = 95\text{mV}/I_{LED}$$

**SHDN (Pin 4):** Shutdown Pin. Connect to 1.5V or higher to enable device; 0.4V or less to disable device.

**GND (Pin 5, SC70 Package):** Ground Pin. Connect to Pin 2 and to local ground plane

**VIN (Pin 5/Pin 6 SC70 Package):** Input Supply Pin. Must be locally bypassed.

## BLOCK DIAGRAM

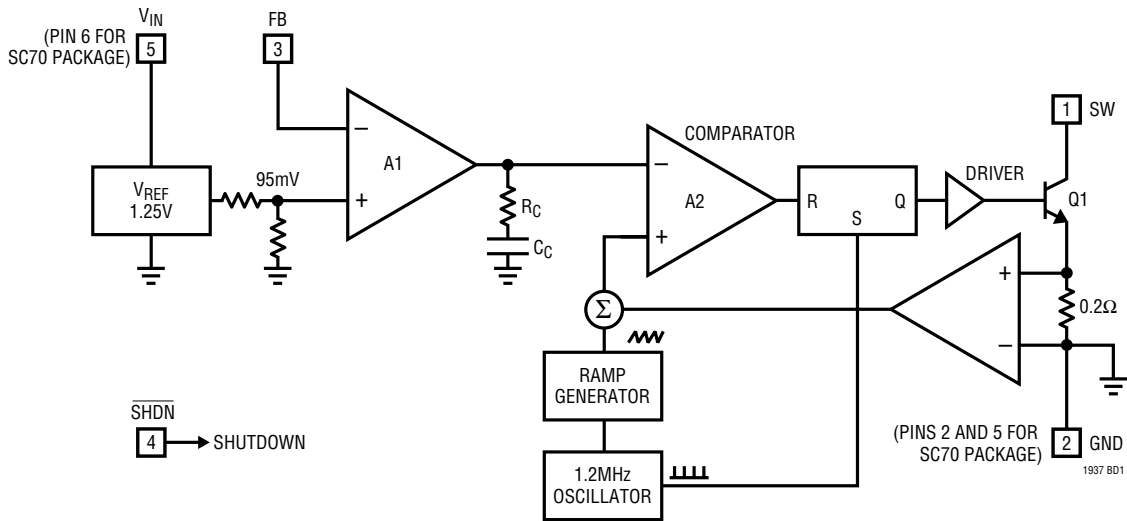

Figure 2. LT1937 Block Diagram

## OPERATION

The LT1937 uses a constant frequency, current mode control scheme to provide excellent line and load regulation. Operation can be best understood by referring to the block diagram in Figure 2. At the start of each oscillator cycle, the SR latch is set, which turns on the power switch Q1. A voltage proportional to the switch current is added to a stabilizing ramp and the resulting sum is fed into the positive terminal of the PWM comparator A2. When this voltage exceeds the level at the negative input of A2, the SR latch is reset turning off the power switch. The level at the negative input of A2 is set by the error amplifier A1, and is simply an amplified version of the difference between the feedback voltage and the reference voltage of 95mV. In this manner, the error amplifier sets the correct peak current level to keep the output in regulation. If the error amplifier's output increases, more current is delivered to the output; if it decreases, less current is delivered.

### Minimum Output Current

The LT1937 can regulate three series LEDs connected at low output currents, down to approximately 4mA from a 4.2V supply, without pulse skipping, using the same external components as specified for 15mA operation. As current is further reduced, the device will begin skipping

pulses. This will result in some low frequency ripple, although the LED current remains regulated on an average basis down to zero. The photo in Figure 3 details circuit operation driving three white LEDs at a 4mA load. Peak inductor current is less than 50mA and the regulator operates in discontinuous mode, meaning the inductor current reaches zero during the discharge phase. After the inductor current reaches zero, the switch pin exhibits ringing due to the LC tank circuit formed by the inductor in combination with switch and diode capacitance. This ringing is not harmful; far less spectral energy is contained in the ringing than in the switch transitions. The ringing can be damped by application of a 300Ω resistor across the inductor, although this will degrade efficiency.

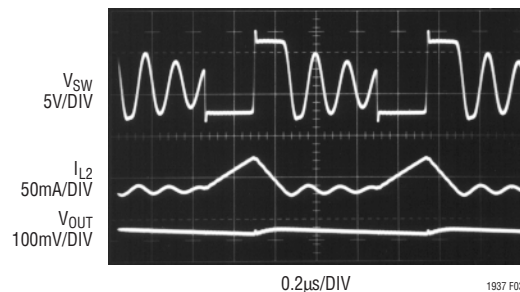

Figure 3. Switching Waveforms at  $I_{LED} = 4mA$ ,  $V_{IN} = 3.6V$

## APPLICATIONS INFORMATION

### Inductor Selection

A 22μH inductor is recommended for most LT1937 applications. Although small size and high efficiency are major concerns, the inductor should have low core losses at 1.2MHz and low DCR (copper wire resistance). Some inductors in this category with small size are listed in Table 1. The efficiency comparison of different inductors is shown in Figure 4.

**Table 1. Recommended Inductors**

PART NUMBER	DCR (Ω)	CURRENT RATING (mA)	MANUFACTURER
LQH3C220	0.71	250	Murata 814-237-1431 www.murata.com
ELJPC220KF	4.0	160	Panasonic 714-373-7334 www.panasonic.com
CDRH3D16-220	0.53	350	Sumida 847-956-0666 www.Sumida.com
LB2012B220M	1.7	75	Taiyo Yuden 408-573-4150 www.t-yuden.com
LEM2520-220	5.5	125	Taiyo Yuden 408-573-4150 www.t-yuden.com

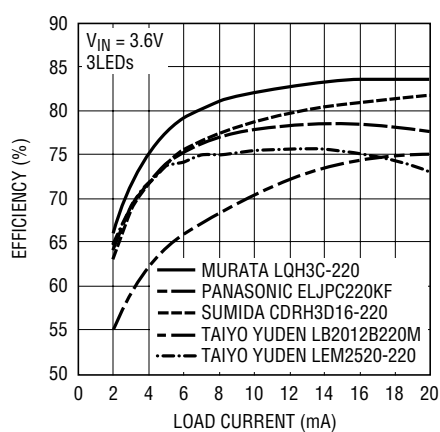

**Figure 4. Efficiency Comparison of Different Inductors**

### Capacitor Selection

The small size of ceramic capacitors makes them ideal for LT1937 applications. X5R and X7R types are recommended because they retain their capacitance over wider voltage and temperature ranges than other types such as Y5V or Z5U. A 1μF input capacitor and a 0.22μF output capacitor are sufficient for most LT1937 applications.

**Table 2. Recommended Ceramic Capacitor Manufacturers**

MANUFACTURER	PHONE	URL
Taiyo Yuden	408-573-4150	www.t-yuden.com
AVX	843-448-9411	www.avxcorp.com
Murata	814-237-1431	www.murata.com
Kemet	408-986-0424	www.kemet.com

### Diode Selection

Schottky diodes, with their low forward voltage drop and fast reverse recovery, are the ideal choices for LT1937 applications. The forward voltage drop of a Schottky diode represents the conduction losses in the diode, while the diode capacitance ( $C_T$  or  $C_D$ ) represents the switching losses. For diode selection, both forward voltage drop and diode capacitance need to be considered. Schottky diodes with higher current ratings usually have lower forward voltage drop and larger diode capacitance, which can cause significant switching losses at the 1.2MHz switching frequency of the LT1937. A Schottky diode rated at 100mA to 200mA is sufficient for most LT1937 applications. Some recommended Schottky diodes are listed in Table 3.

**Table 3. Recommended Schottky Diodes**

PART NUMBER	FORWARD CURRENT (mA)	VOLTAGE DROP (V)	DIODE CAPACITANCE (pF)	MANUFACTURER
CMDSH-3	100	0.58 at 100mA	7.0 at 10V	Central 631-435-1110 www.centrasemi.com
CMDSH2-3	200	0.49 at 200mA	15 at 10V	Central 631-435-1110 www.centrasemi.com
BAT54	200	0.53 at 100mA	10 at 25V	Zetex 631-543-7100 www.zetex.com

## APPLICATIONS INFORMATION

### LED Current Control

The LED current is controlled by the feedback resistor (R1 in Figure 1). The feedback reference is 95mV. The LED current is  $95\text{mV}/R1$ . In order to have accurate LED current, precision resistors are preferred (1% is recommended). The formula and table for R1 selection are shown below.

$$R1 = 95\text{mV}/I_{\text{LED}} \quad (1)$$

Table 4. R1 Resistor Value Selection

$I_{\text{LED}}$ (mA)	R1 ( $\Omega$ )
5	19.1
10	9.53
12	7.87
15	6.34
20	4.75

### Open-Circuit Protection

In the cases of output open circuit, when the LEDs are disconnected from the circuit or the LEDs fail, the feedback voltage will be zero. The LT1937 will then switch at a high duty cycle resulting in a high output voltage, which may cause the SW pin voltage to exceed its maximum 36V rating. A zener diode can be used at the output to limit the voltage on the SW pin (Figure 5). The zener voltage should be larger than the maximum forward voltage of the LED string. The current rating of the zener should be larger than 0.1mA.

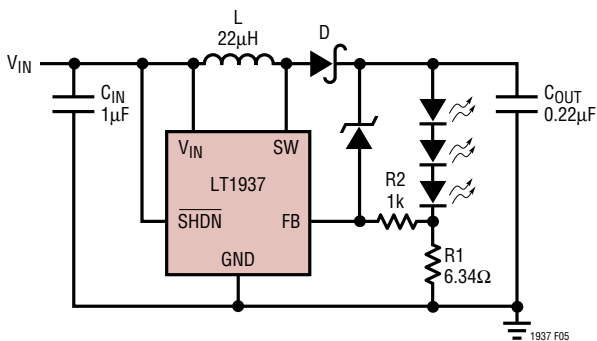

Figure 5. LED Driver with Open-Circuit Protection

### Dimming Control

There are four different types of dimming control circuits:

#### 1. Using a PWM Signal to $\overline{\text{SHDN}}$ Pin

With the PWM signal applied to the  $\overline{\text{SHDN}}$  pin, the LT1937 is turned on or off by the PWM signal. The LEDs operate at either zero or full current. The average LED current increases proportionally with the duty cycle of the PWM signal. A 0% duty cycle will turn off the LT1937 and corresponds to zero LED current. A 100% duty cycle corresponds to full current. The typical frequency range of the PWM signal is 1kHz to 10kHz. The magnitude of the PWM signal should be higher than the minimum  $\overline{\text{SHDN}}$  voltage high. The switching waveforms of the  $\overline{\text{SHDN}}$  pin PWM control are shown in Figures 6a and 6b.

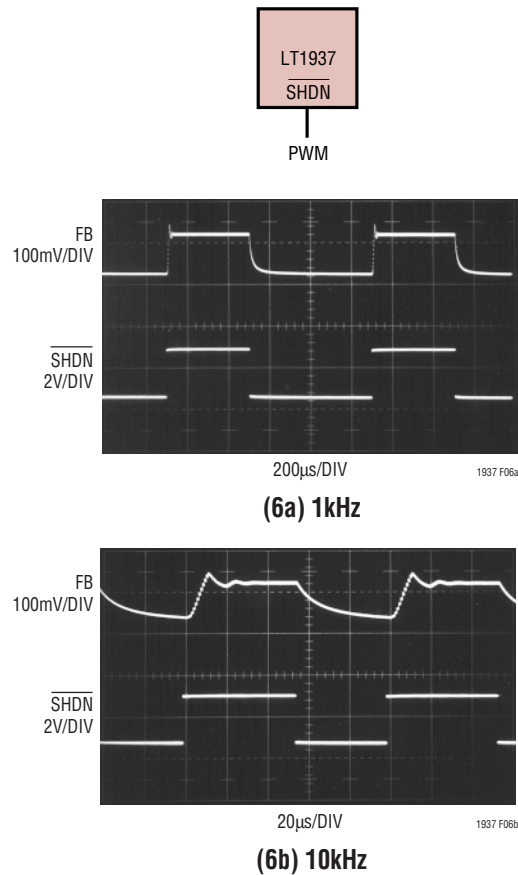

Figure 6. PWM Dimming Control Using the  $\overline{\text{SHDN}}$  Pin

## APPLICATIONS INFORMATION

### 2. Using a DC Voltage

For some applications, the preferred method of brightness control is a variable DC voltage to adjust the LED current. The dimming control using a DC voltage is shown in Figure 7. As the DC voltage increases, the voltage drop on R2 increases and the voltage drop on R1 decreases. Thus, the LED current decreases. The selection of R2 and R3 will make the current from the variable DC source much smaller than the LED current and much larger than the FB pin bias current. For  $V_{DC}$  range from 0V to 2V, the selection of resistors in Figure 7 gives dimming control of LED current from 0mA to 15mA.

### 3. Using a Filtered PWM Signal

The filtered PWM signal can be considered as an adjustable DC voltage. It can be used to replace the variable DC voltage source in dimming control. The circuit is shown in Figure 8.

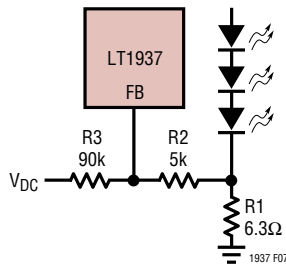

Figure 7. Dimming Control Using a DC Voltage

### 4. Using a Logic Signal

For applications that need to adjust the LED current in discrete steps, a logic signal can be used as shown in Figure 9. R1 sets the minimum LED current (when the NMOS is off).  $R_{INC}$  sets how much the LED current increases when the NMOS is turned on. The selection of R1 and  $R_{INC}$  follows formula (1) and Table 4.

### Start-up and Inrush Current

To achieve minimum start-up delay, no internal soft-start circuit is included in LT1937. When first turned on without an external soft-start circuit, inrush current is about 200mA as shown in Figure 10. If soft-start is desired, the recommended circuit and the waveforms are shown in Figure 11. If both soft-start and dimming are used, a 10kHz PWM signal on  $\overline{SHDN}$  is not recommended. Use a lower frequency or implement dimming through the FB pin as shown in Figures 7, 8 or 9.

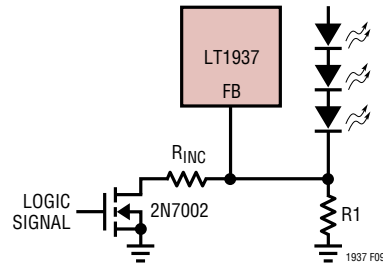

Figure 9. Dimming Control Using a Logic Signal

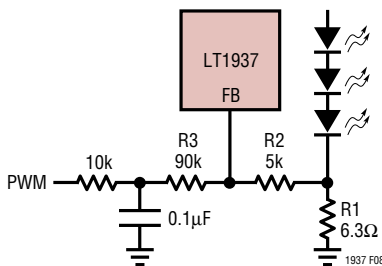

Figure 8. Dimming Control Using a Filtered PWM Signal

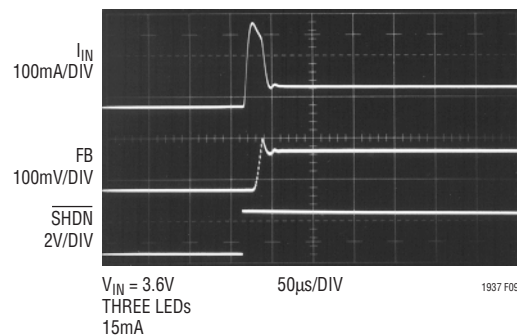
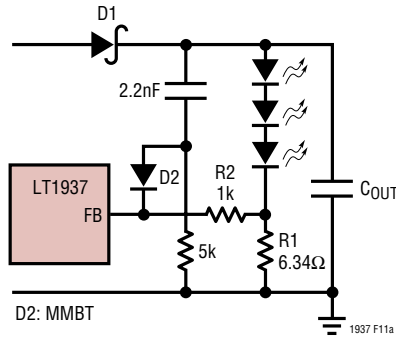
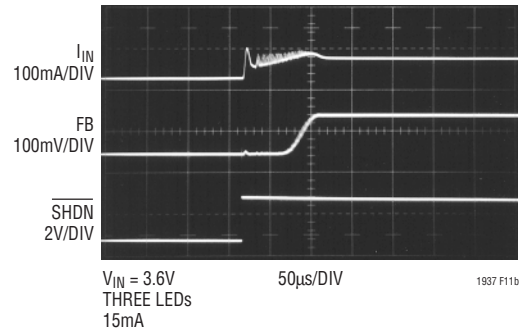

Figure 10. Start-Up Waveforms Without Soft-Startup Circuit

APPLICATIONS INFORMATION



(11a) Recommended Soft-Startup Circuit



(11b) Soft-Startup Waveforms

Figure 11. Recommended Soft-Startup Circuit and Waveforms

Board Layout Consideration

As with all switching regulators, careful attention must be paid to the PCB board layout and component placement. To maximize efficiency, switch rise and fall times are made as short as possible. To prevent electromagnetic interference (EMI) problems, proper layout of the high frequency switching path is essential. The voltage signal of the SW pin has sharp rise and fall edges. Minimize the length and

area of all traces connected to the SW pin and always use a ground plane under the switching regulator to minimize interplane coupling. In addition, the ground connection for the feedback resistor R1 should be tied directly to the GND pin and not shared with any other component, ensuring a clean, noise-free connection. Recommended component placement is shown in Figure 12.

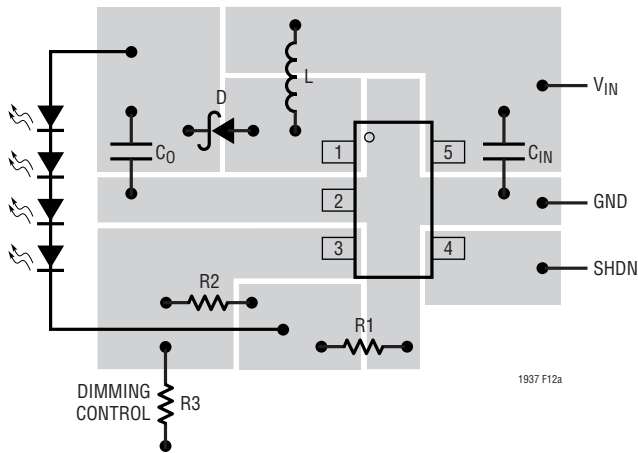

(SOT-23 Package)

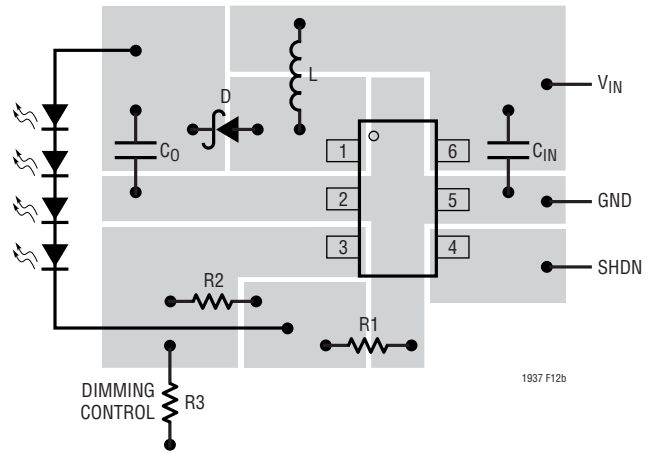

(SC70 Package)

Figure 12. Recommended Component Placement



# TYPICAL APPLICATIONS

Li-Ion to Two White LEDs

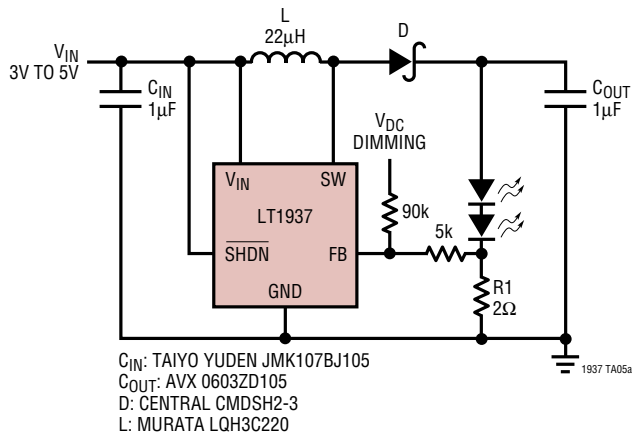

Two LED Efficiency

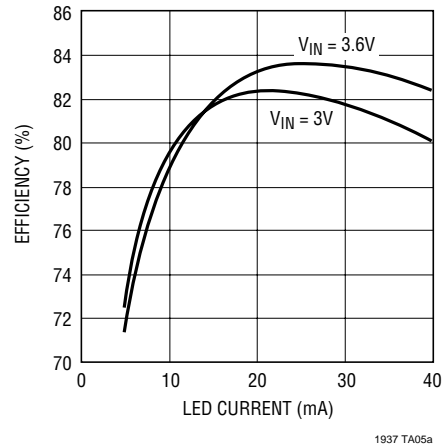

Li-Ion to Three White LEDs

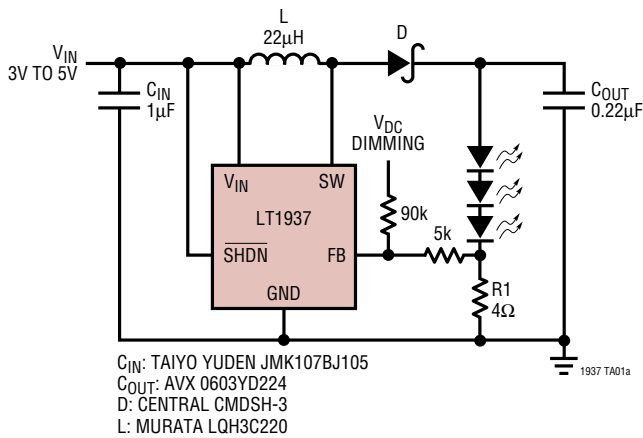

Three LED Efficiency

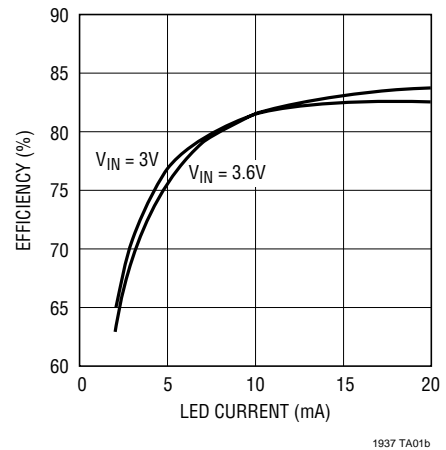

TYPICAL APPLICATIONS

Li-Ion to Five White LEDs

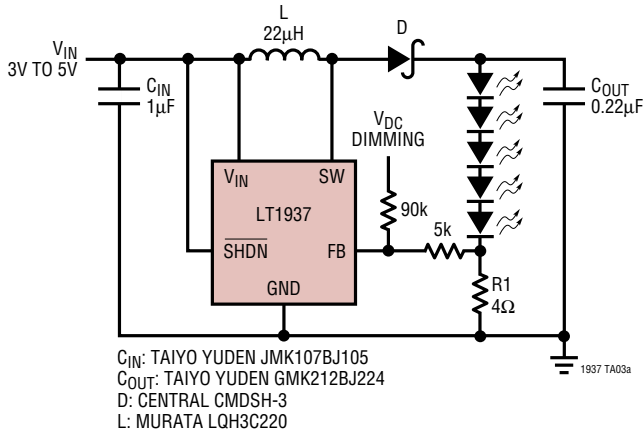

Five LED Efficiency

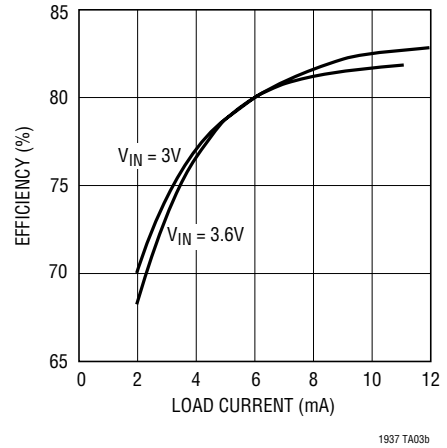

5V to Seven White LEDs

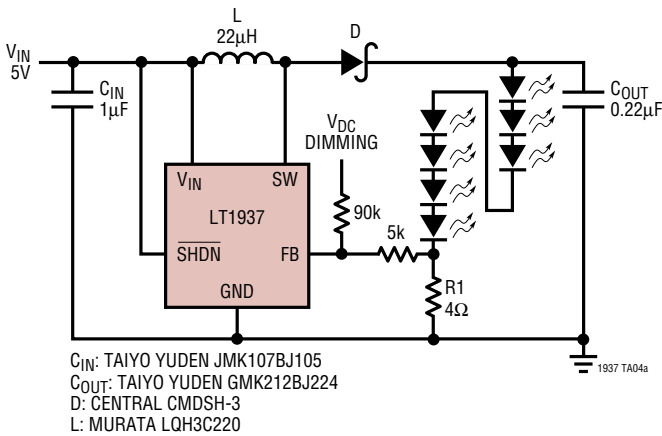

Seven LED Efficiency

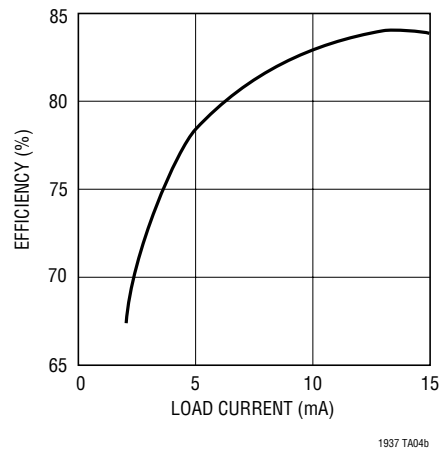

# PACKAGE DESCRIPTION

## S5 Package 5-Lead Plastic TSOT-23 (Reference LTC DWG # 05-08-1635)

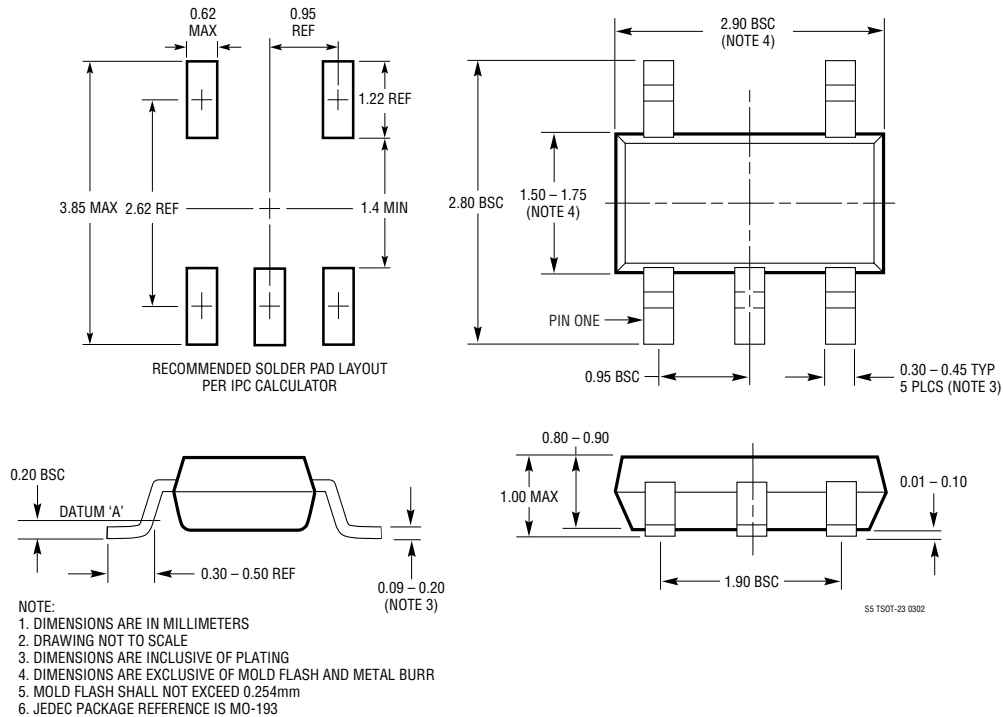

## SC6 Package 6-Lead Plastic SC70 (Reference LTC DWG # 05-08-1638)

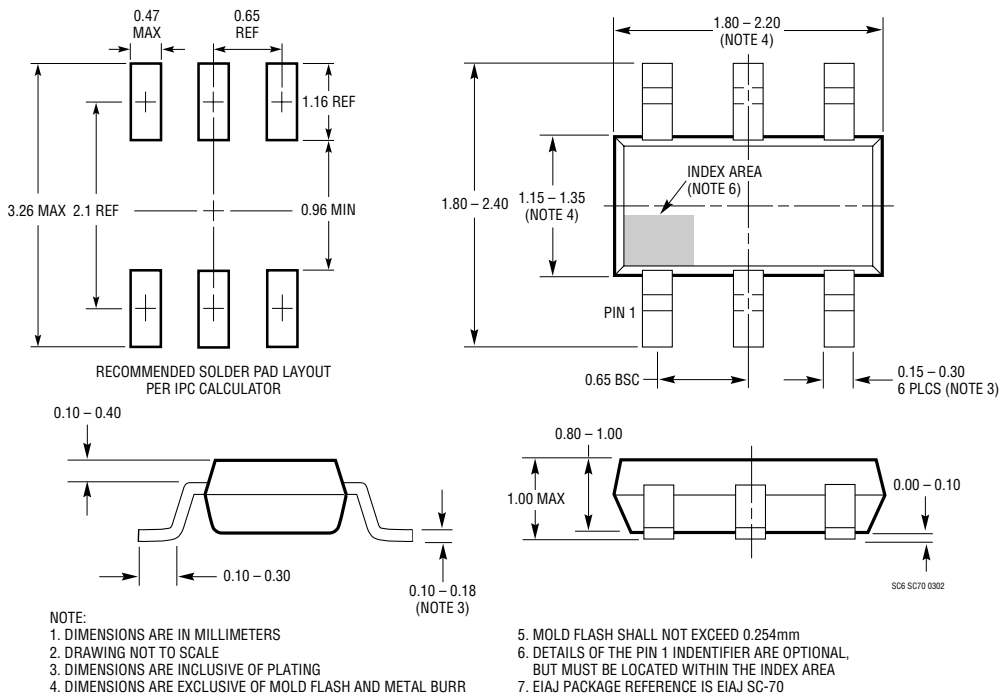

**TYPICAL APPLICATION**

Li-Ion to Four White LEDs

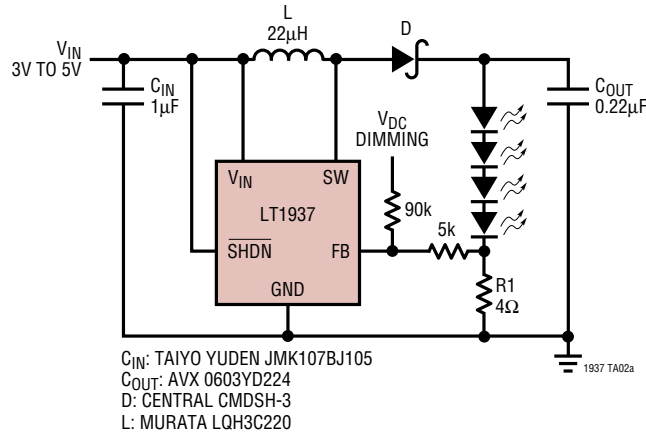

Four LED Efficiency

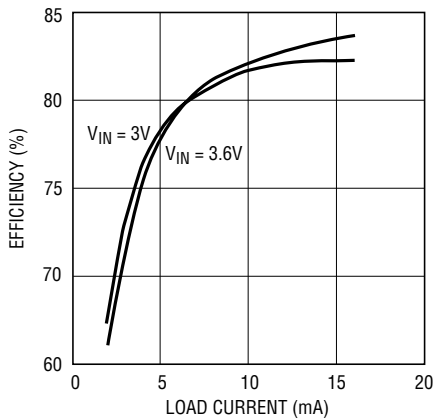

Switching Waveforms

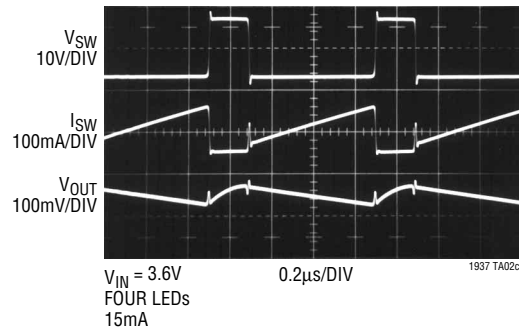

**RELATED PARTS**

PART NUMBER	DESCRIPTION	COMMENTS
LT1615	Micropower Step-Up Converter in ThinSOT	Up to 36V Output; 20µA IQ, VIN: 1V to 15V, Can Drive Up to Six LEDs, ThinSOT Package
LT1618	Constant Current/Voltage Step-Up DC/DC	1.4MHz, Drives Up to 20 LEDs, MS10 Package
LT1932	White LED Step-Up Converter in ThinSOT	1.2MHz, VIN = 1V to 10V, Drives Up to Eight LEDs from 3V Input, ThinSOT Package
LT1944/LT1944-1	Dual Micropower Step-Up Converter	VIN = 1.2V to 15V, Two Independent DC/DCs, Up to 36VOUT, 20µA IQ, MS10 Package
LTC®3200/LTC3200-5	Low Noise White LED Charge Pump Converter For up to 6 LEDs	2MHz, 100mA, No Inductor Required, MS8/ThinSOT Packages
LTC3201	Ultralow Noise White LED Charge Pump Converter For up to 6 LEDs	1.8MHz, 100mA, No Inductor Required, DAC Brightness Adj, MS8 Package
LTC3202	Low Noise White LED Fractional Charge Pump Converter For up to 6 LEDs	1.5MHz, 125mA, No Inductor Required, Digital Brightness Adjust, MS8 Package