



PRODUCT OVERVIEW

The **D1U4CS-W-2200-12-HxxC** is a 2200 Watt, power-factor-corrected (PFC) front-end power supply for hot-swapping redundant systems. The main output is 12V with a standby output of 5V or 3.3V. Packaged in a 1U low profile enclosure, it is designed to deliver reliable bulk power to servers, workstations, storage systems or any 12V distributed power architecture systems requiring high power density. The highly efficient electrical and thermal design with internal cooling fans supports reliable operation conditions. The D1U4CS-W-2200-12-HxxC is designed to autorecover from overtemperature fault. Status information is provided with front panel LEDs, logic signals and an I²C management interface. Four units can be packaged into an optional 19" 1U power shelf to provide up to 8.8kW of power.

FEATURES

- 2200W (220Vac), 1100W (110Vac) Output Power
- Certified to Climate Savers Computing InitiativeSM and 80 PLUS[®] Gold efficiency
- 12V Main Output, 3.3V or 5V Standby Output
- 1U height: 4.0" x 14.0" x 1.6"
- 24.5 Watts per cubic inch density
- N+1 redundancy capable, including hot plugging (up to 4 in parallel)
- Active Current Sharing on main output; ORing FET
- Overvoltage, Overcurrent, Overtemperature protection
- Internal cooling fans (variable speed)
- I²C Bus Interface, PSMI compliant
- RoHS compliant
- Optional 1U x 19" Power-Shelf

ORDERING GUIDE

Model Number	Power Output High Line AC	Power Output Low Line AC	Main Output	Standby Output	Airflow
D1U4CS-W-2200-12-HC4C	2200W	1100W	12.12V	3.3V	Back to front
D1U4CS-W-2200-12-HC3C	2200W	1100W	12.12V	3.3V	Front to back
D1U4CS-W-2200-12-HA4C	2200W	1100W	12.12V	5V	Back to front
D1U4CS-W-2200-12-HA3C	2200W	1100W	12.12V	5V	Front to back

INPUT CHARACTERISTICS

Parameter	Conditions	Min.	Typ.	Max.	Units
Input Voltage Operating Range		90	115/230	264	Vac
Input Frequency		47	60	63	Hz
Turn-on Input Voltage	Ramp up	81		89	Vac
Turn-off Input Voltage	Ramp down	70.5		78	
Maximum Input Current	Low Line AC 90Vac			13	Arms
	High Line AC 180Vac			13	
Inrush Current	Cold start between 0-1msec			16.5	Apk
Power Factor	Output load >90%	0.95			
	Output load >50%	0.95			

OUTPUT VOLTAGE CHARACTERISTICS

Output Voltage	Parameter	Conditions	Min.	Typ.	Max.	Units
12V	Voltage Set Point Accuracy			12.12		Vdc
	Line and Load Regulation		11.76		12.48	
	Ripple Voltage & Noise ¹	20MHz Bandwidth			120	mV p-p
	Output Current		9		180	A
	Load Capacitance				30000	µF
5Vsb	Voltage Set Point Accuracy			5		Vdc
	Line and Load Regulation	20MHz Bandwidth	4.85		5.15	
	Ripple Voltage & Noise ¹				50	mV p-p
	Operating Range		0		5	A
	Load Capacitance				10000	µF
3.3Vsb	Voltage Set Point Accuracy			3.3		Vdc
	Line and Load Regulation	20MHz Bandwidth	3.2		3.4	
	Ripple Voltage & Noise ¹				50	mV p-p
	Operating Range		0		6	A
	Load Capacitance				10000	µF

¹ Ripple and noise are measured with 0.1 µF of ceramic capacitance and 10 µF of tantalum capacitance on each of the power supply outputs. The output noise requirements apply over a 0 Hz to 20 MHz bandwidth. A short coaxial cable with 50ohm scope termination is used.



OUTPUT CHARACTERISTICS					
Parameter	Conditions	Min.	Typ.	Max.	Units
Remote Sense			120		mV
Efficiency (230V) excluding fan load	20% load	88	89.1		%
	50% load	92	93.0		
	100% load	88	92.2		
Output Rise Monotonicity	Overshoot less than 10% for all outputs, no voltage negative between 10% to 95% during ramp up				
Startup Time	AC ramp up		1.5		s
	PS_On activated		150		ms
Transient Response	12V Ramp 1A/μs			±360	mV
	5Vsb Ramp 1A/μs			±150	
	3.3Vsb Ramp 1A/μs			±100	
Current sharing accuracy (up to 4 in parallel)	At 100% load			±7	%
Hot Swap Transients	All outputs remain in regulation			5	%
Holdup Time	100% load	12			ms

ENVIRONMENTAL CHARACTERISTICS					
Parameter	Conditions	Min.	Typ.	Max.	Units
Storage Temperature Range	Non-condensing	-40		70	°C
Operating Temperature Range	D1U4CS-W-2200-12-HC4C and D1U4CS-W-2200-12-HA4C models	0		50	
	D1U4CS-W-2200-12-HC3C and D1U4CS-W-2200-12-HA3C models	0		40	
Operating Humidity	Non-condensing	10		90	%
Storage Humidity		5		90	
Shock	30G non operating				
Sinusoidal Vibration	0.5G, 5 – 500 Hz operating				
MTBF	Calculated per Bellcore at Ta=30°C	400K			hrs
	Demonstrated	400K			hrs
Acoustic	ISO 7779-1999			60	dB LpAm
Safety Approvals	CAN/CSA C22.2 No 60950-1-07, Am.1:2011 UL 60950-1-2011, 2nd Ed. UL 60950-1, 2nd Ed. IEC60950-1:2005 (2nd Ed.) w A1:2009, EN 60950-1:2006+A11:2009 +A1:2010 +A12:2011				
Input Fuse	Power Supply has internal 20A/250V fast blow fuse on the AC line input				
Material Flammability	UL 94V-0				
Switching Frequency	TBD				
Weight	4.5lbs (2.1kg)				

PROTECTION CHARACTERISTICS						
Output Voltage	Parameter	Conditions	Min.	Typ.	Max.	Units
12V	Overtemperature	Autorestart	55		65	°C
	Overvoltage	Latching	13.1		14.1	V
	Overcurrent	Latching	197		225	A
5Vsb	Overvoltage	Latching	5.6		6.2	V
	Overcurrent	Brick wall, autorecovery	5.5		6.2	A
3.3Vsb	Overvoltage	Latching	3.5		4.0	V
	Overcurrent	Brick wall, autorecovery	6.5		8.0	A

ISOLATION CHARACTERISTICS					
Parameter	Conditions	Min.	Typ.	Max.	Units
Insulation Safety Rating / Test Voltage	Input to Output - Reinforced	3000			Vrms
	Input to Chassis - Basic	1500			Vrms
Isolation	Output to Chassis				
	Output to Output				
Grounding	Main Output Return and Standby Output Return are connected internally. 100kΩ resistor parallel with 100nF capacitor is connected between Return and power supply chassis. Main Output Return should be connected to the System Chassis				

STATUS INDICATORS AND CONTROL SIGNALS			
Status	Conditions	Description	
LEDs	Off	No AC to all Power Supply	
	Flashing Green	Main Output Absent	
	Flashing Amber	Calibration Mode; not a normal operating condition	
	Solid Amber		PW Fail or PWOK Low. Note: The LED will also show Solid Amber if the power module is: 1. Not correctly installed within its slot (in the host system shelf) with PS_KILL (Pin B5) correctly terminated. 2. Operated externally (as a standalone power module) and is not connected to an Output Connector Card ACAN-32 (see Optional Accessories) that correctly terminates PS_KILL (Pin B5).
			Power Supply Good
I ² C Registers	Refer to Application Note #ACAN-33		

EMISSIONS AND IMMUNITY		
Characteristic	Standard	Compliance
Input Current Harmonics	IEC/EN 61000-3-2	Complies
Voltage Fluctuation and Flicker	IEC/EN 61000-3-3	Complies
Conducted Emissions	FCC 47 CFR Part 15/CISPR 22/EN55022	Class A, 6dB margin
Radiated Emissions	FCC 47 CFR Part 15/CISPR 22/EN55022	Class A, 6dB margin
ESD Immunity	IEC/EN 61000-4-2	4kV contact discharge
		8kV operational air discharge
		15kV non-operational air discharge
Radiated Field Immunity	IEC/EN 61000-4-3	Complies
Electrical Fast Transients/Burst Immunity	IEC/EN 61000-4-4	Complies
Surge Immunity	IEC/EN 61000-4-5	1kV/2kV, Performance Criteria A
RF Conducted Immunity	IEC/EN 61000-4-6	3 Vac, 80% AM, 1kHz, Performance Criteria A
Magnetic Field Immunity	IEC/EN 61000-4-8	3 A/m
Voltage dips, interruptions	IEC/EN 61000-4-11	Complies

OUTPUT CONNECTOR AND SIGNAL SPECIFICATION

DC and Signal Connector: FCI PowerBlade # 51732-048LF

P1	P2	P3	P4	P5	P6	P7	P8	P9	P10	x1	x2	x3	x4	x5	x6	
VOUT	VOUT	VOUT	VOUT	VOUT	VRTN	VRTN	VRTN	VRTN	VRTN	AC_OK/H	PW_OK/H	Vsb RETURN	Vsb RETURN	Vsb +OUT	Vsb +OUT	D
										SPARE	SMB/Alert	Vsb RETURN	Vsb RETURN	Vsb +OUT	Vsb +OUT	C
										I_SHARE	I ² C ADRO	I ² C ADR1	I ² C ADR2	PS_KILL	PS_PRESENT	B
										SENSE +	SENSE -	I ² C DATA	I ² C CLOCK	SPARE	PS_ON/L	A

mate-last pins

Pin Assignment	Signal Name	Description	High Level Low Level	I Max
P1 to P5	VOUT	Main output voltage		
P6 to P10	VRTN	Main output voltage, return		
A1	Sense +	VOUT remote sense, positive node input, connected to the +ve load point		
A2	Sense -	VOUT remote sense, negative node input, connected to the -ve load point		
C5, C6, D5, D6	Vsb	Standby voltage output		
C3, C4, D3, D4	Vsb Return	Standby voltage, return, tied internally to Output Return		
B1	I_Share	Active load sharing bus	0 – 8V	-4 mA / +5 mA
D1	AC_OK/H	Input AC Voltage “OK” signal output (Internal pull up is 10kΩ to Vsb)	>2.1V <0.8V	+4 mA -2 mA
D2	PW_OK/H	Internal pull up of 10KΩ to Vsb	>2.1V <0.8V	+4 mA -2 mA
C2	SMB/Alert	SMB/Alert signal output (open collector)		
B5	PS_Kill	Floating pin will turn off P/S (shorter pin, last-make and first-break contact for hot plugging). This signal overrides PS-On in disabling the Main Output	>2.1V (open) <0.8V (active, PS:On)	N/A
B6	PS_Present	Internally tied to Vsb Return	0 V	
A6	PS_On/L	Internal 3.3KΩ pull-up to Vsb (accepts open collector/ drain drive). This signal to be pulled low to turn-on power supply	>2.1V (open, or 3.3V) <0.8V (active, PS:On)	
A3	I ² C Data	I ² C serial data bus; internal 4.64KΩ pull-up to Vsb		
A4	I ² C Clock	I ² C serial clock bus; internal 4.64KΩ pull-up to Vsb		
B2	I ² C Adr0	Address input 0, internal 10KΩ pull-up to Vsb	>2.1V <0.8V	±1 mA
B3	I ² C Adr1	Address input 1, internal 10KΩ pull-up to Vsb	>2.1V <0.8V	±1 mA
B4	I ² C Adr2	Address input 2, internal 10KΩ pull-up to Vsb	>2.1V <0.8V	±1 mA

D1U4CS MATING CONNECTORS

12V D1U4 mating connector

	Press Fit		Solder ¹	
	Straight	Right Angle	Straight	Right Angle
Murata-PS	N/A	4321-01454-0	N/A	N/A
FCI	51742-11002400AALF	51762-11002400ABLF	N/A	N/A

¹ Solder connector recommended for board thickness of <0.090

www.murata-ps.com/support

WIRING DIAGRAM FOR OUTPUT

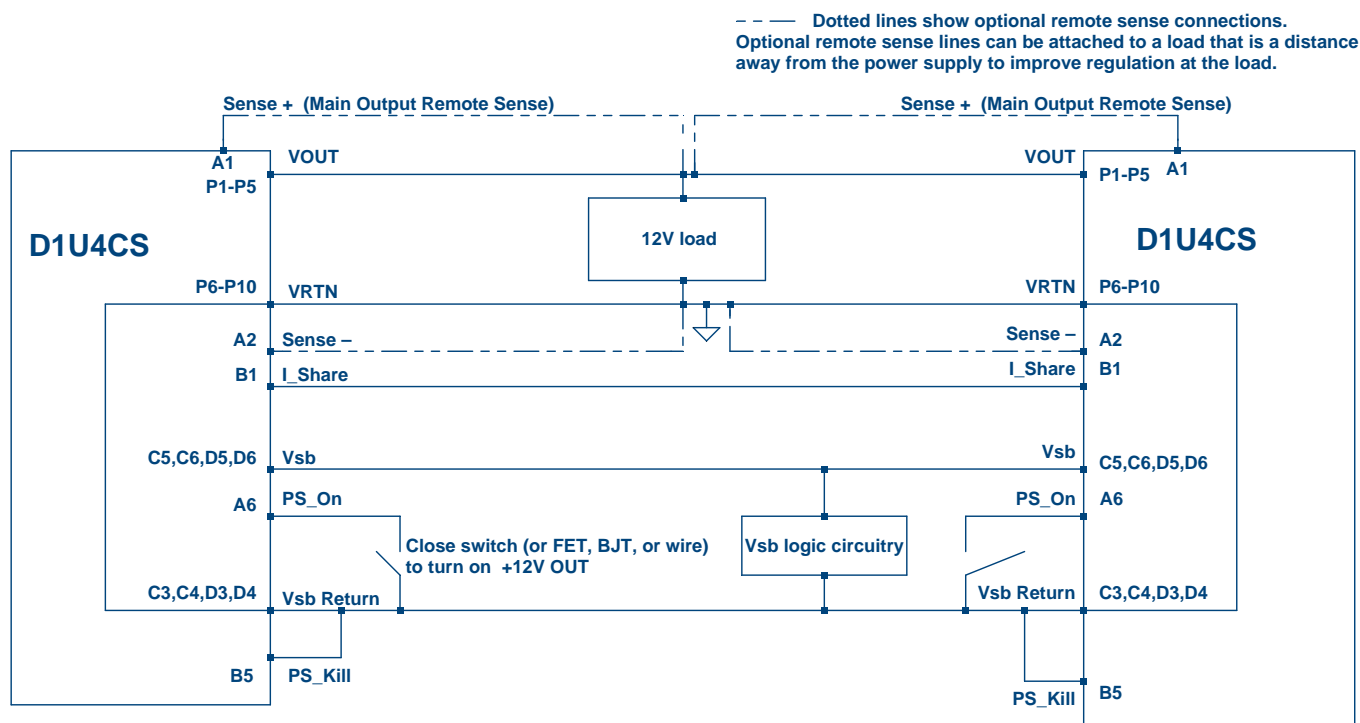

CURRENT SHARING NOTES

12V Output: Current sharing is achieved using the active current share method. (See wiring diagram for connection details.)

The total combined load must be below 2200W at startup. Current sharing can be achieved with or without remote sense connected to the common load.

VSB outputs can be tied together for redundancy but total combined output power must not exceed 25W. The VSB output has internal ORing MOSFET for additional redundancy / internal short protection.

The current share pin B1 is a connection between the two units. It is input and/or output as the voltage on the line controls the current share. A power supply will respond to a change in this voltage but a power supply can also change the voltage depending on the load drawn from it. On a single unit this would read 8V at 100% load. For two units sharing load then this should read 4V for perfect current sharing.

Up to 6 units can be paralleled together. Please consult your Murata sales representative if operation with more than six units in parallel is needed.

MECHANICAL DIMENSIONS - D1U4CS-W-2200-12-HxxC

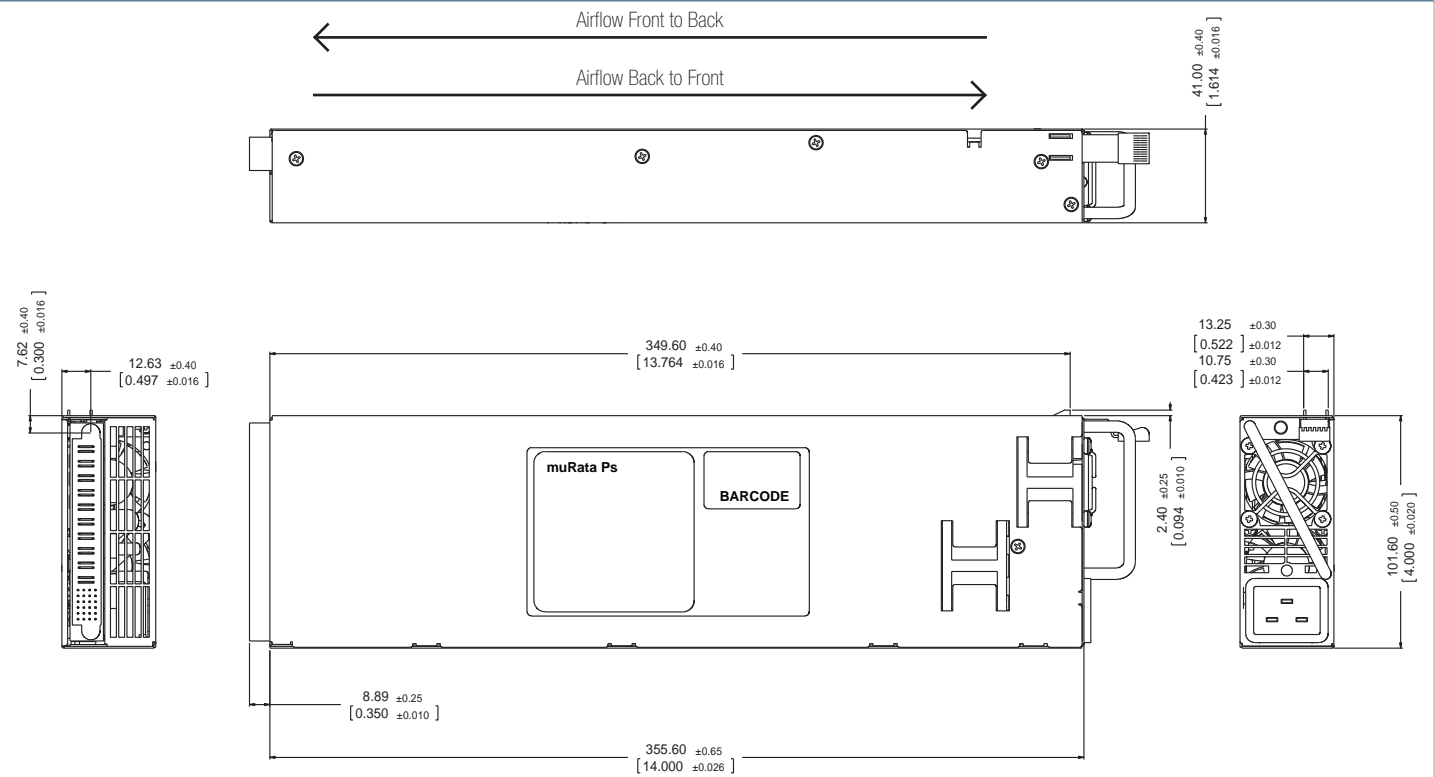

AC Input Connector: The AC input connector is standard IEC C20 20A.
 Dimensions: 4.00" x 14.00" x 1.61" [101.6mm x 355.6mm x 41.0mm]

OPTIONAL ACCESSORIES

Description	Part Number
12V D1U4CS-12 output connector card	D1U4CS-12-CONC

APPLICATION NOTES

Document Number	Description	Link
ACAN-32	D1U4CS-12-CONC Output Connector Card	www.murata-ps.com/data/apnotes/acan-32.pdf
ACAN-33	D1U4CS-W Communication Protocol	www.murata-ps.com/data/apnotes/acan-33.pdf
ACAN-37	D1U4CS-x EEPROM Specification	www.murata-ps.com/data/apnotes/acan-37.pdf

Murata Power Solutions, Inc.
 11 Cabot Boulevard, Mansfield, MA 02048-1151 U.S.A.
 ISO 9001 and 14001 REGISTERED



This product is subject to the following **operating requirements** and the **Life and Safety Critical Application Sales Policy**:
 Refer to: <http://www.murata-ps.com/requirements/>

Murata Power Solutions, Inc. makes no representation that the use of its products in the circuits described herein, or the use of other technical information contained herein, will not infringe upon existing or future patent rights. The descriptions contained herein do not imply the granting of licenses to make, use, or sell equipment constructed in accordance therewith. Specifications are subject to change without notice. © 2015 Murata Power Solutions, Inc.