

# HMC7053

v04.0216

## KA-BAND BLOCK UPCONVERTER



### Typical Applications

- Satellite communications
  - Commercial
  - Military

### General Description

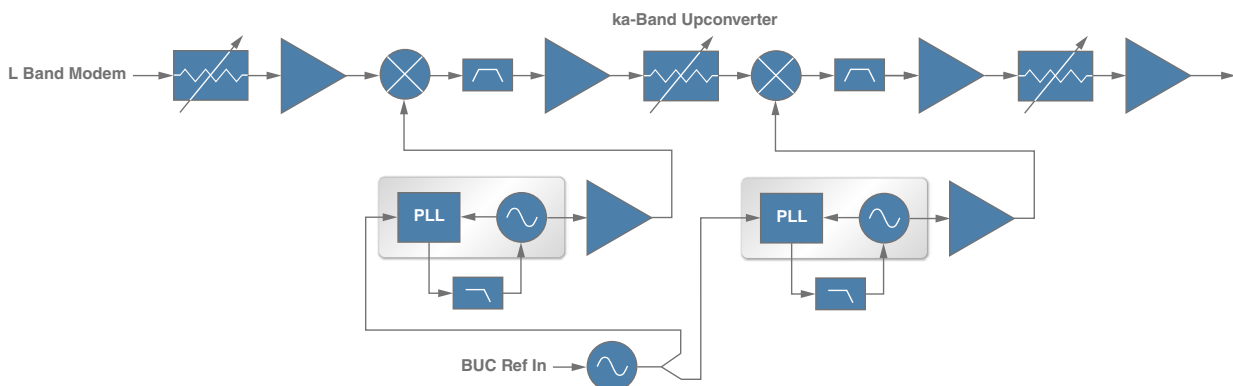
The HMC7053 is a fully integrated Ka-Band Block Upconverter. The unit is designed for single carrier use in satellite communications. It covers both Commercial and Military bands and is designed to meet military environmental conditions.

### Features

- Compact Design
- Dual L Band Inputs
- Dual Upconversion to ensure no phase inversion
- SMA(F) Input Connectors
- K(F) Output Connector
- Digital Gain control
- Thermal Monitoring and Gain Compensation
- Size: 4.88" x 4.42" x 0.48"
- Weight: 0.6 lbs.
- Designed for Military Environments

Parameter	Typical
Input Frequency Range (GHz)	1 - 2
Output Frequency Range (GHz)	29 - 31
Conversion Gain (dB)	+20
Gain Flatness - 1 GHz (dB)	3
Gain Flatness - 10 MHz (dB)	0.7
Input Power (dBm)	-30 - +5
Output P1dB (dBm)	+2
Phase Noise (dBc/Hz)	
10 Hz	-50
100 Hz	-66
1 kHz	-93
10 kHz	-92
100 kHz	-94
1 MHz	-104
10 MHz	-118
Spurious (dBc)	-60
AM/PM Conversion (Deg/dB)	2
BUC DC Power (VDC @ AMP)	5.75V @ 2.25 A
Size (in)	4.88" x 4.42" x 0.48"

### Functional Block Diagram



## KA-BAND BLOCK UPCONVERTER

## Electrical Specifications

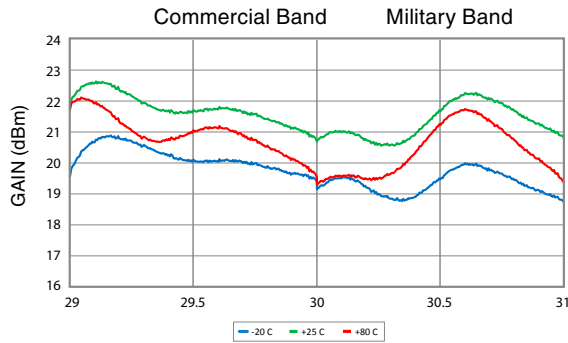
Parameter	Specification			Units	Notes
	Min.	Typ.	Max.		
Input IF frequency	1		2	GHz	
Frequency range (MIL)	30		31	GHz	Military band
Frequency range (COMM)	29		30	GHz	Commercial band
Reference frequency		10		MHz	
Reference input power	-5		5	dBm	
Reference output power	-7.5		5	dBm	
Input IF Power			5	dBm	
Conversion gain	+20		+20	dB	
Gain flatness - 1 Ghz			3	dB	
Gain flatness - 40 Mhz			0.7	dB	
Gain variation (over temp)			±1.0	dB	
Gain stability			±0.25	dB/24h	
Gain control	30			dB	
Group delay - 40 MHz			±0.25	nSec	
Group delay - 10 MHz			±0.1	nSec	
Internal TX (VSWR)		2:1			
External TX (VSWR)		2:1			
10MHz reference (VSWR)		2:1			
100MHz reference (VSWR)		2:1			
RF output (VSWR)		2:1			
P1dB		+2		dBm	
TX maximum power (Psat)		+3		dBm	3 dB compression
Output IP3		+16.5		dBm	
LO leakage			-20	dBm	
Image rejection			-60	dBc	
Signal related spurious			-60	dBc	
Non-signal related spurs			-40	dBm	
TX single sideband spurs			-40	dBm	
<b>Phase Noise</b>					
10 Hz		-50		dBc/Hz	
100 Hz		-66		dBc/Hz	
1 KHz		-93		dBc/Hz	
10 KHz		-92		dBc/Hz	
100 KHz		-94		dBc/Hz	
1 MHz		-104		dBc/Hz	

### Electrical Specifications

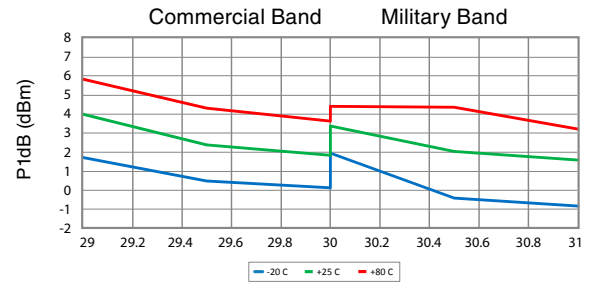
Parameter	Specification			Units	Notes
	Min.	Typ.	Max.		
10 MHz		-118		dBc/Hz	
AM/PM conversion	0		2	Deg/dB	
Int IF to Ext IF isolation	70			dB	
VDD (BUC)	5.5		5.9	VDC	
+21V	19.5		23	VDC	
-5V	-5.1		-4.9	VDC	
IDD (BUC)			2.5	A	
I (+21V)			50	mA	
I (-5V)			75	mA	
DC Power Max			16.3	W	

## KA-BAND BLOCK UPCONVERTER

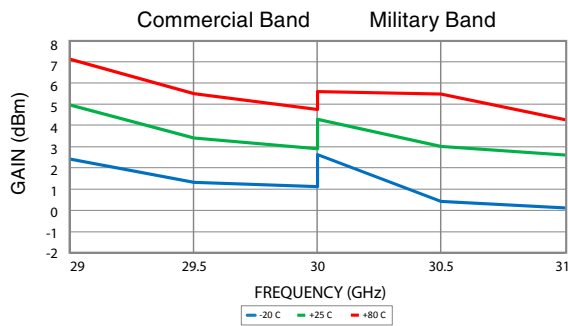
**Figure 1. Small Signal Gain**



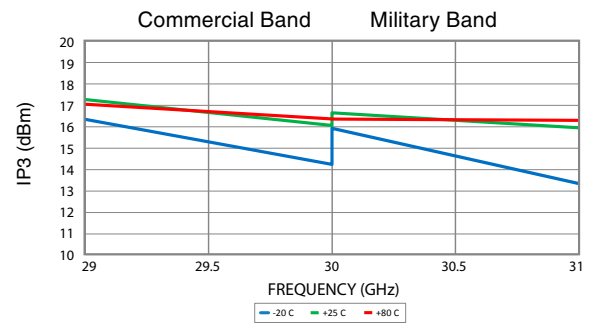
**Figure 2. Output P1dB**



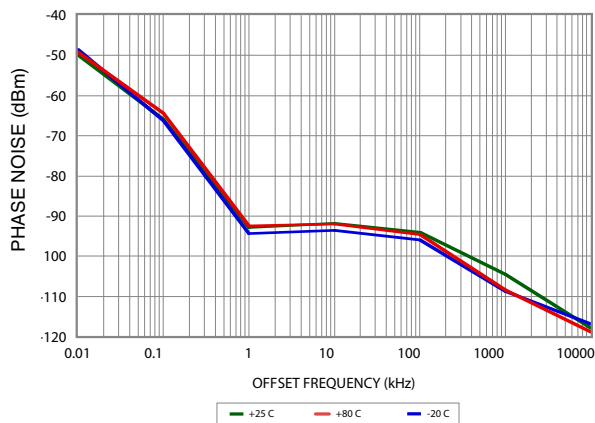
**Figure 3. Saturated Output Power**



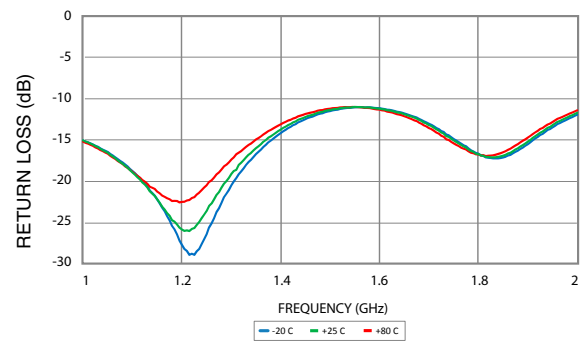
**Figure 4. IP3**



**Figure 5. Phase Noise (carrier @ 30 GHz)**

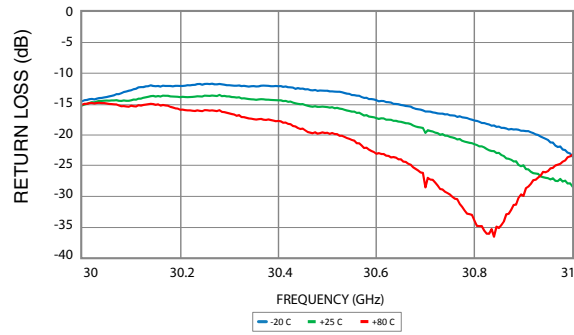


**Figure 6. Input Return Losses**

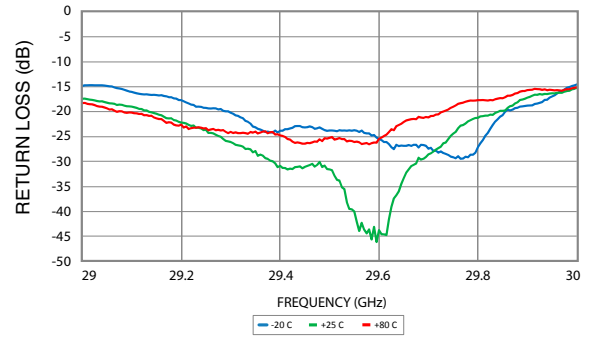


## KA-BAND BLOCK UPCONVERTER

**Figure 7. Output Return Losses (Military Band)**



**Figure 8. Output Return Losses (Commercial Band)**



**KA-BAND BLOCK UPCONVERTER****Table 1. Absolute Maximum Ratings**

Parameter	Max Rating
VDD_BUC	+20V
21 VDC_BUC	+30V
-5 VDC_BUC	-20V
Operating temp	-20 to +80 °C
Storage temp	-55 to +125 °C
Continuous Pdiss	16.3W
ESD sensitivity	Class 1A

**Table 2. RF I/O Ports**

Port #	I/O	Function	Description
J3	I	L_LP_INT_TX MDM_INT_10MHz_REF	Internal modem input with 10 Hz reference signal
J4	I	L_LP_EXT_TX MDM_EXT_10MHz_REF	External modem input with 10 Hz reference signal
J6	O	BUC_10MHz_REF_OUT	10 MHz reference signal output
J7	I	BUC_100MHz_REF_IN	100 MHz reference signal input
J8	O	BUC_RF_OUT	Upconverter module (BUC) RF output port K(F)

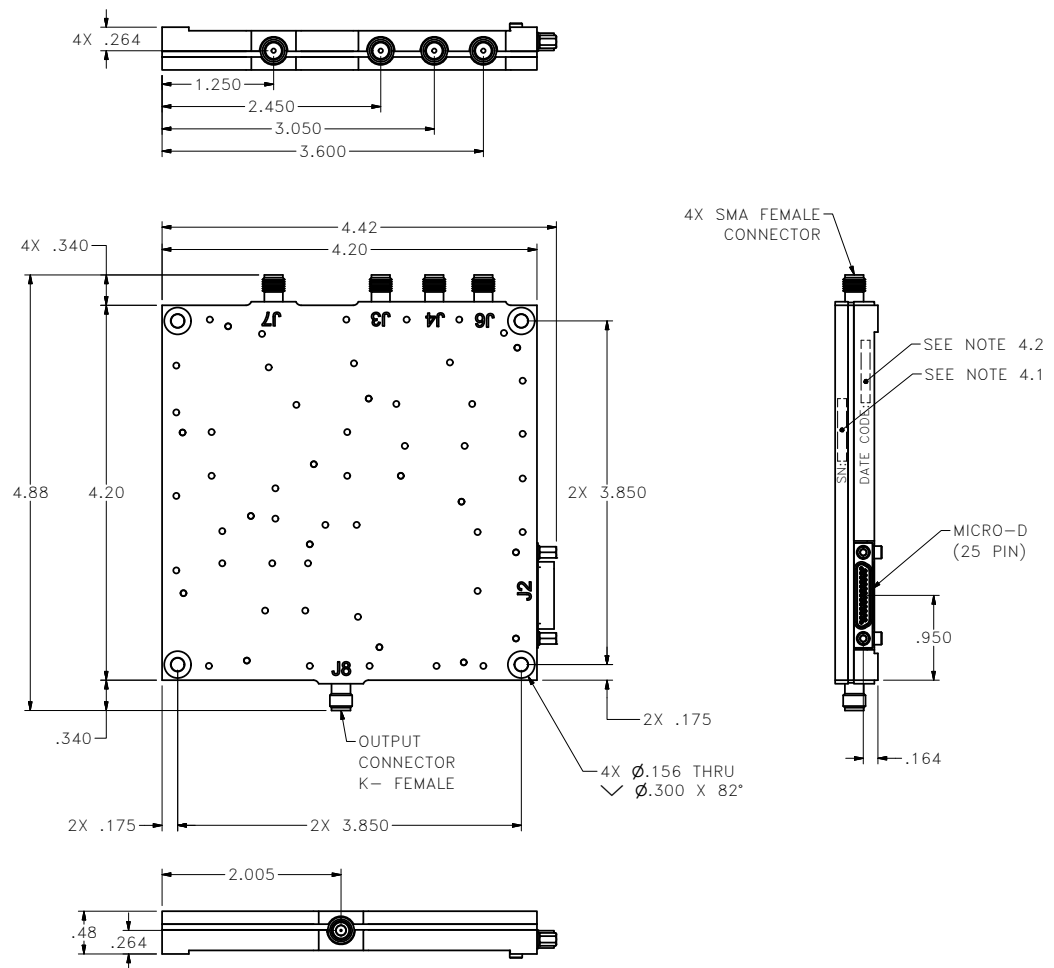
## KA-BAND BLOCK UPCONVERTER

**Table 4. J2 BUC Connector Pin Out**

Pin #	Signal/Voltage	Description
1	VDD_BUC	BUC positive voltage supply
2	VDD_BUC	
3	VDD_BUC	
4	21VDC	BUC positive voltage supply to PLLs
5	GND	
6	SPARE	
7	MDM_SELECT	Modem input selection. High (3.3V): internal modem, Low (0V): external modem
8	BUC_LO_LOCK	PLL lock indication. High (3.3V): unlocked, Low (0V): locked
9	TX_GAIN_CNTL_LE	Gain control signal latch enable
10	GND	
11	RESERVED FOR VENDOR USE: (RS232_RXD0)	
12	BUC_HPA_12C_SDA	I <sup>2</sup> C bus data
13	GND	
14	GND	
15	GND	
16	GND	
17	-5VDC	BUC negative voltage supply
18	HPA_MUTE	
19	GND	
20	TX_BAND_SELECT	Transmitter band selection. High (3.3V): commercial band 29-30 GHz, Low (0V): military band 30 -31 GHz
21	TX_GAIN_CNTL_SERIN	Gain control signal serial input
22	TX_GAIN_CNTL_CLK	Gain control signal clock
23	RESERVED FOR VENDOR USE: (RS232_RXD0)	
24	GND	
25	BUC_HPA_12C_SCL	I <sup>2</sup> C bus clock

## KA-BAND BLOCK UPCONVERTER

### Outline Drawing



#### NOTES:

- 1.0 MATERIAL: ALUMINUM
- 2.0 FINISH: BASEPLATE AND COVER CHEMICAL CONVERSION COAT PER MIL-DTL-5541, TYPE II, CLASS 3
- 3.0 TOLERANCES:
  - 3.1 XX =  $\pm$ .02
  - 3.2 XXX =  $\pm$ .010
- 4.0 MARKINGS TO BE LABEL OR ENGRAVED AND LOCATED APPROXIMATELY AS SHOWN
- 4.1 UNIT TO BE SERIALLY MARKED IN ACCORDANCE WITH PURCHASE CONTRACT WHERE "X" = SEQUENTIAL NUMBERS
- 4.2 DATE CODE MARKINGS TO SHOW DATE IN "MMYY:" FORMAT

### Package Information

Size	Weight
4.88" x 4.42" x 0.48"	0.6 lbs