

# TDK RF Products for Wireless LAN

2004/3/5

## for 2.4GHz

### Antennas

| Start Freq.<br>MHz | Stop Freq.<br>MHz | Type                   | Gain<br>dBi(MAX) | Return loss<br>dB (MAX) | Size<br>mm (typ.) | Part No.                       |
|--------------------|-------------------|------------------------|------------------|-------------------------|-------------------|--------------------------------|
| 2400               | 2485              | SMD ceramic patch      | -3               | -2                      | 7.0x7.0x1.5       | <a href="#">CABPB0715A</a>     |
| 2400               | 2500              | SMD ceramic patch      | -1               | -2.5                    | 7.0x7.0x3.0       | <a href="#">CABPB0730A</a>     |
| 2400               | 2500              | SMD ceramic patch      | +2               | -6                      | 12.0x12.0x4.0     | <a href="#">CABPB1240A</a>     |
| 2400               | 2500              | SMD ceramic multilayer | +1               | -15                     | 8.0x3.0x1.2       | <a href="#">ANT8030-2R4-01</a> |

Sample Available  
Under Developing

**CERAMIC PATCH ANTENNA FOR Bluetooth & 2.4 GHz W-LAN**

SAMPLE P/N: CABPB0715A (7x7x1.5 mm type)

**[MECHANICAL DIMENSIONS]**

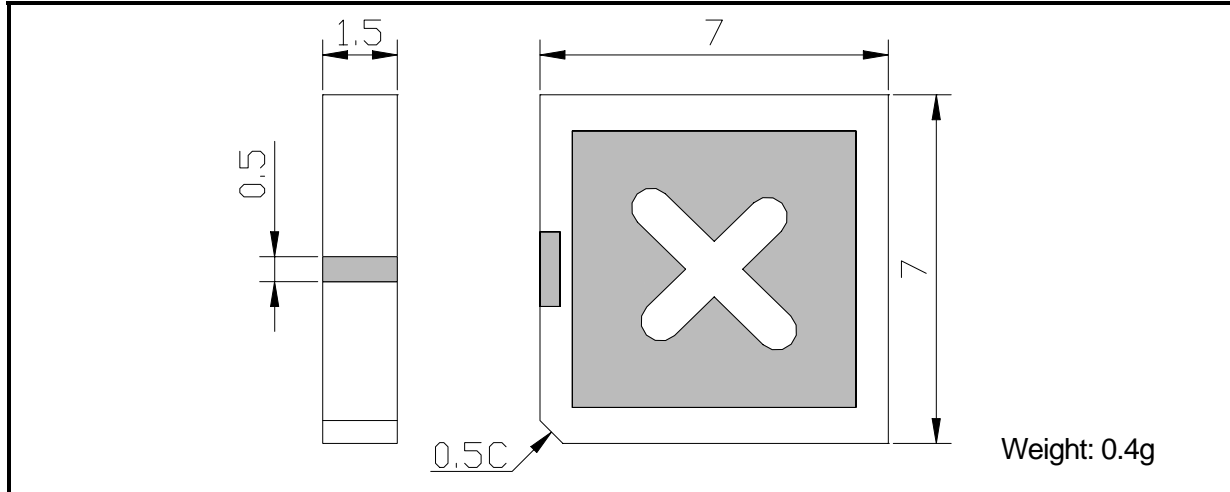

**[ELECTRICAL CHARACTERISTICS]**

| PARAMETER        | FREQ (MHz) | MIN. | MAX. | UNIT |
|------------------|------------|------|------|------|
| Centre frequency |            | 2442 |      | MHz  |
| Bandwidth        |            | 85   |      | MHz  |
| Antenna Gain     | 2400-2485  |      | -3   | dBi  |
| Impedance        | 2400-2485  | 50   |      | ohm  |
| Return Loss      | 2400-2485  |      | -2   | dB   |
| VSWR             | 2400-2485  |      | 8.5  |      |

|                       |     |     |    |
|-----------------------|-----|-----|----|
| Operating temperature | -30 | +85 | °C |
| Storage temperature   | -40 | +85 | °C |

Note: Please use the  $0\text{dBi} = -2.15\text{dBd}$  to convert antenna gain expressed in dBd.

**[RECOMMENDED PCB PATTERN]**

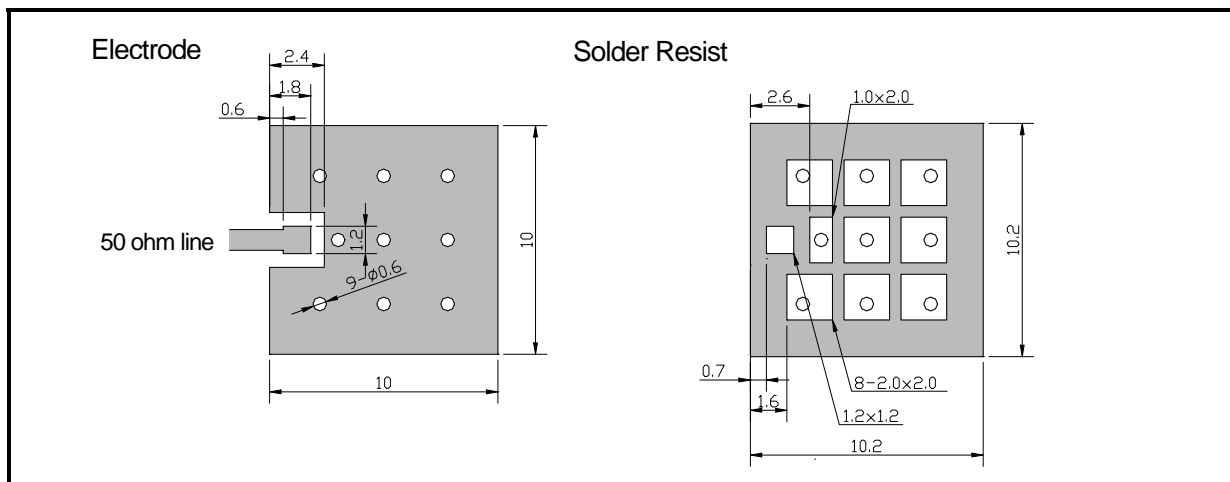

\*Note: This document is PRELIMINARY. All specifications are subject to change without notice and are not guaranteed.

# [RADIATION PATTERN]

- Item: CABPB0715A (7x7x1.5mm Type)
- Standard antenna: Standard dipole (Anritsu)
- Tx antenna: Horn (TECOM)

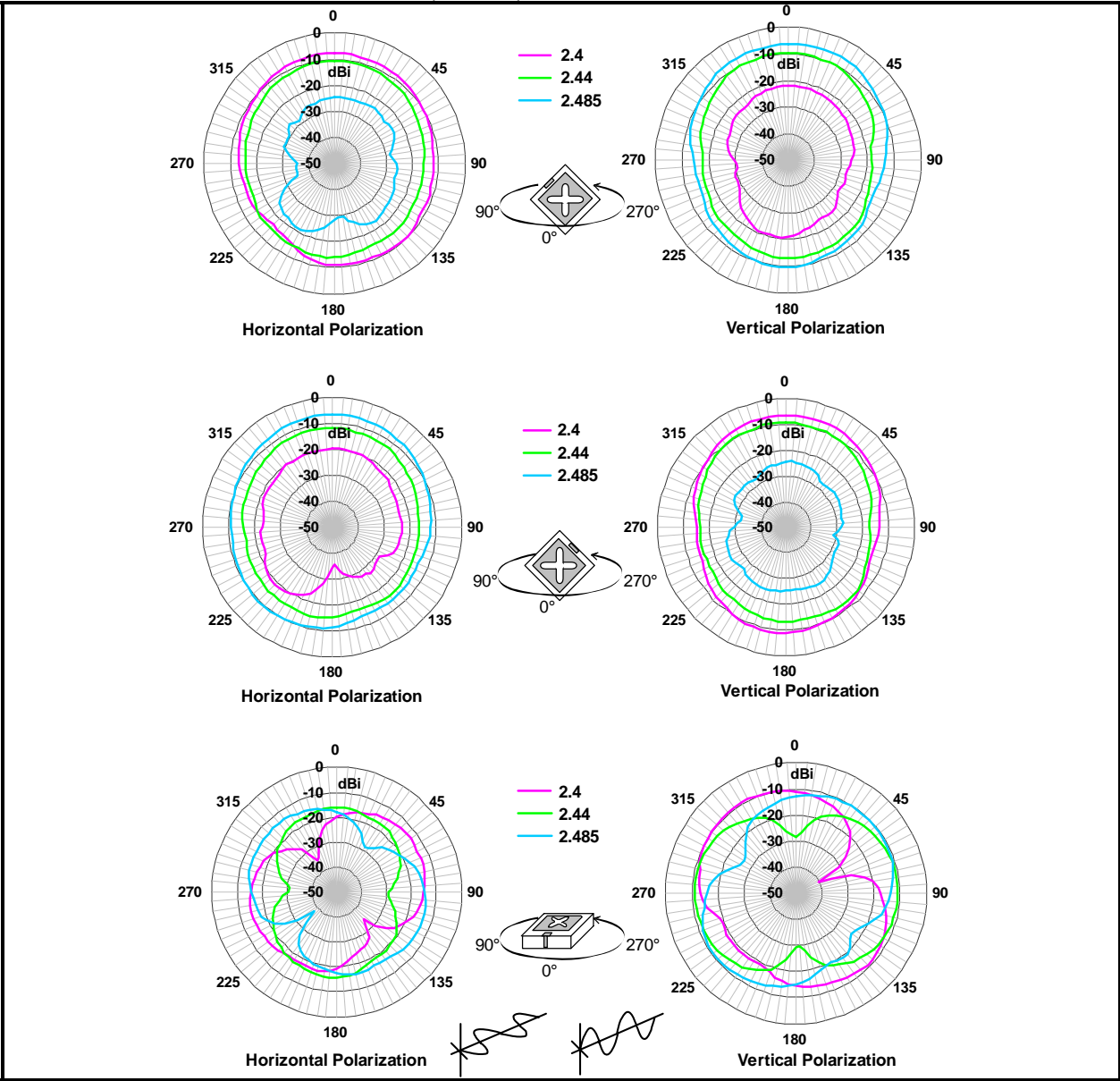

Note: Tested antenna has been soldered on 30x30 mm<sup>2</sup> PCB.

# [ RETURN LOSS&GAIN]

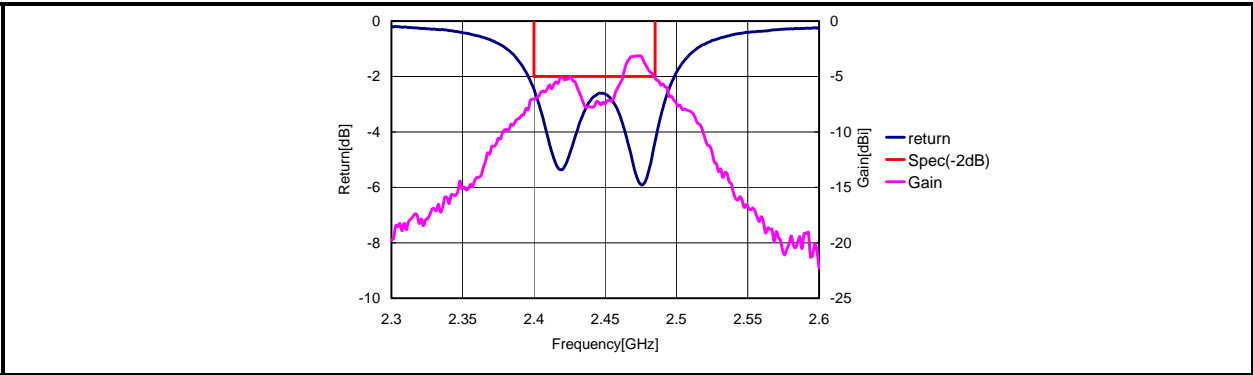

Note: Tested antenna has been soldered on 30x30 mm<sup>2</sup> PCB.

\*Note: This document is PRELIMINARY. All specifications are subject to change without notice and are not guaranteed.

**CERAMIC PATCH ANTENNA FOR Bluetooth & 2.4GHz W-LAN**

**SAMPLE P/N: CABPB0730A (7x7x3 mm type)**

**[MECHANICAL DIMENSIONS]**

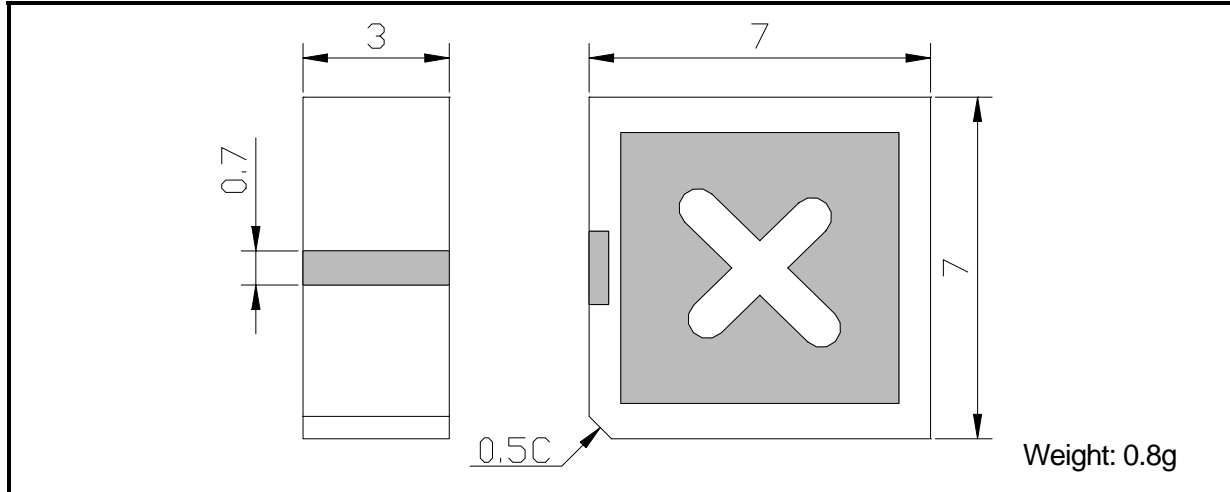

**[ELECTRICAL CHARACTERISTICS]**

| PARAMETER        | FREQ (MHz) | MIN. | MAX. | UNIT |
|------------------|------------|------|------|------|
| Centre frequency |            | 2442 |      | MHz  |
| Bandwidth        |            | 85   |      | MHz  |
| Antenna Gain     | 2400-2485  |      | -1   | dBi  |
| Impedance        | 2400-2485  | 50   |      | ohm  |
| Return Loss      | 2400-2485  |      | -2.5 | dB   |
| VSWR             | 2400-2485  |      | 7    |      |

|                       |     |     |    |
|-----------------------|-----|-----|----|
| Operating temperature | -30 | +85 | °C |
| Storage temperature   | -40 | +85 | °C |

Note: Please use the  $0dBi = -2.15dBd$  to convert antenna gain expressed in dBd.

**[RECOMMENDED PCB PATTERN]**

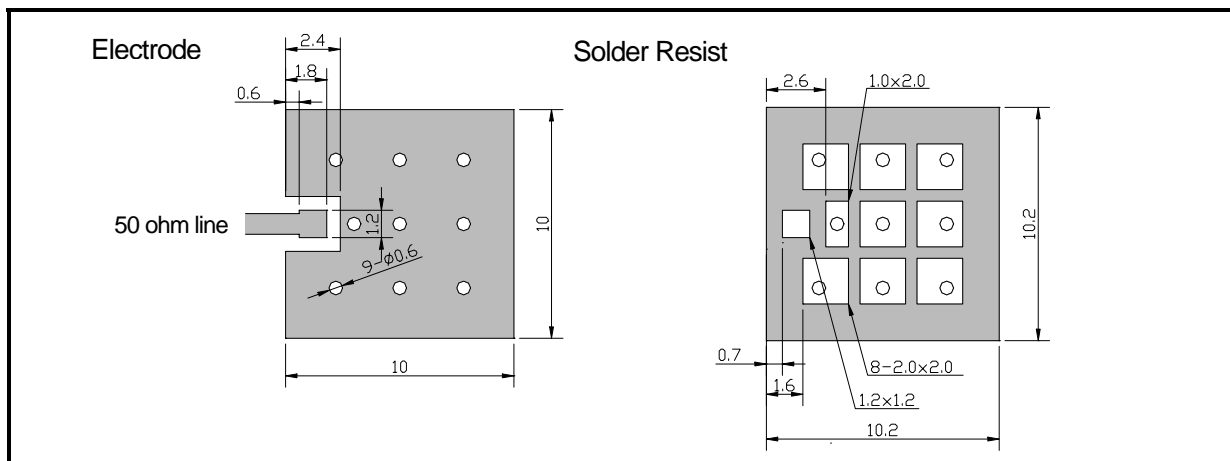

\*Note: This document is PRELIMINARY. All specifications are subject to change without notice and are not guaranteed.

# [RADIATION PATTERN]

- Item: CABPB0730A (7x7x3mm Type)
- Standard antenna: Standard dipole (Anritsu)
- Tx antenna: Horn (TECOM)

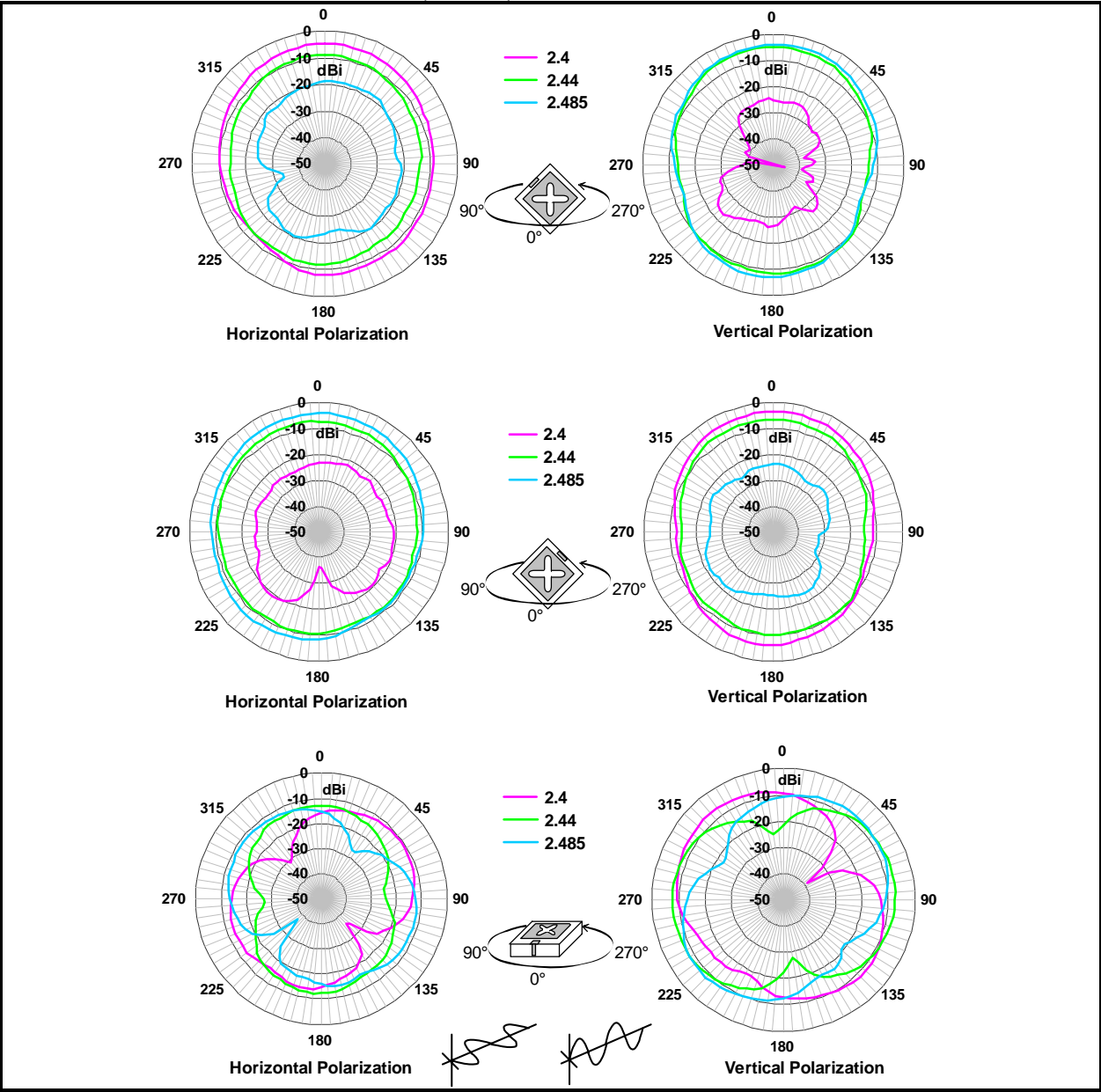

Note: Tested antenna has been soldered on 30x30 mm<sup>2</sup> PCB.

# [ RETURN LOSS&GAIN]

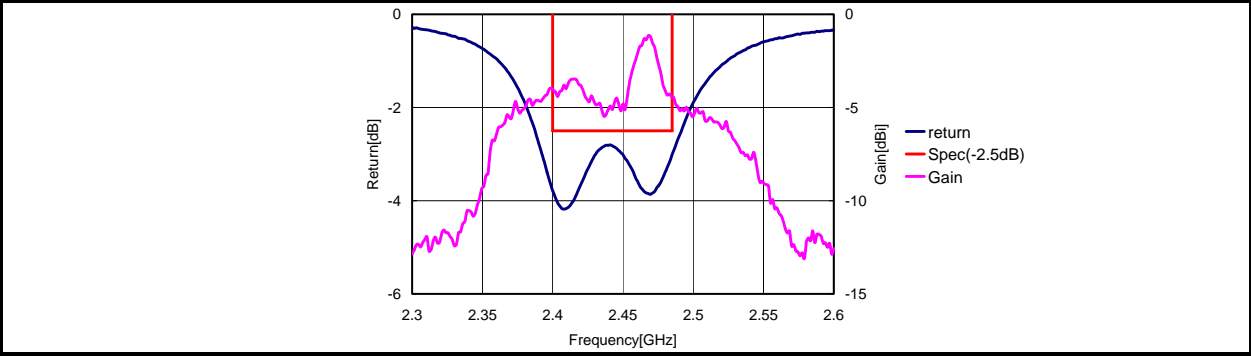

Note: Tested antenna has been soldered on 30x30 mm<sup>2</sup> PCB.

\*Note: This document is PRELIMINARY. All specifications are subject to change without notice and are not guaranteed.

**CERAMIC PATCH ANTENNA FOR Bluetooth & 2.4GHz W-LAN**

**SAMPLE P/N: CABPB1240A (12x12x4 mm type)**

**[MECHANICAL DIMENSIONS]**

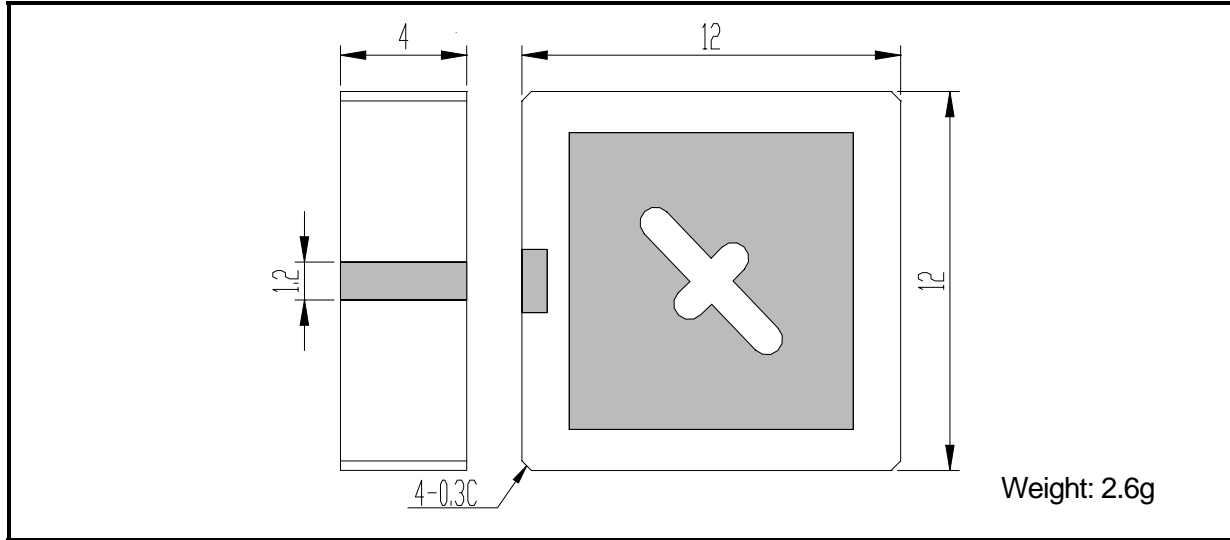

**[ELECTRICAL CHARACTERISTICS]**

| PARAMETER        | FREQ (MHz) | MIN. | MAX. | UNIT |
|------------------|------------|------|------|------|
| Center frequency |            | 2442 |      | MHz  |
| Bandwidth        |            | 85   |      | MHz  |
| Antenna Gain     | 2400-2485  |      | +2   | dBi  |
| Impedance        | 2400-2485  | 50   |      | ohm  |
| Return Loss      | 2400-2485  |      | -6   | dB   |
| VSWR             | 2400-2485  |      | 3    |      |

|                       |     |     |    |
|-----------------------|-----|-----|----|
| Operating temperature | -30 | +85 | °C |
| Storage temperature   | -40 | +85 | °C |

Note: Please use the 0 dBi = -2.15dBd to convert antenna gain expressed in dBd.

**[RECOMMENDED PCB PATTERN]**

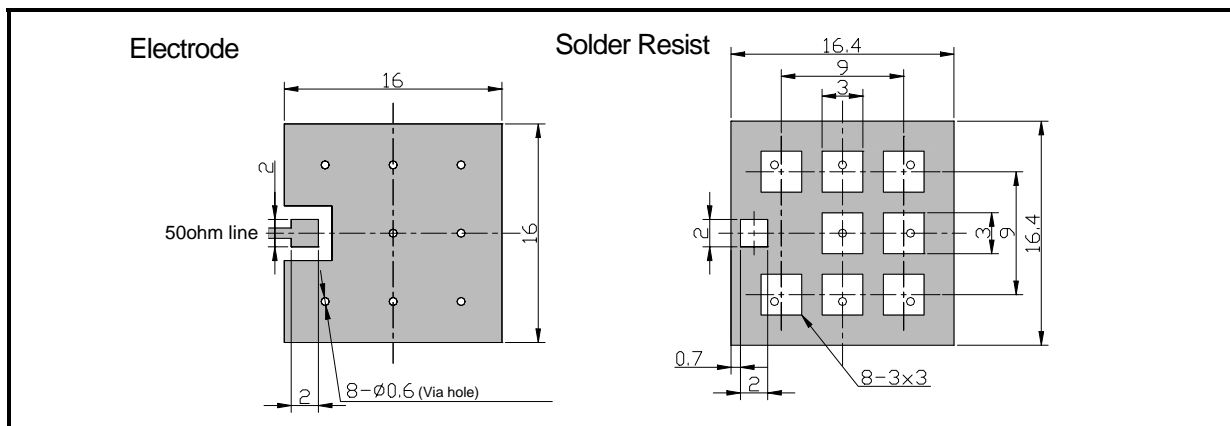

\*Note: This document is PRELIMINARY. All specifications are subject to change without notice and are not guaranteed.

# [RADIATION PATTERN]

- Item: CABPB1240A (12x12x4mm Type)
- Standard antenna: Standard dipole (Anritsu)
- Tx antenna: Horn (Condor Systems)

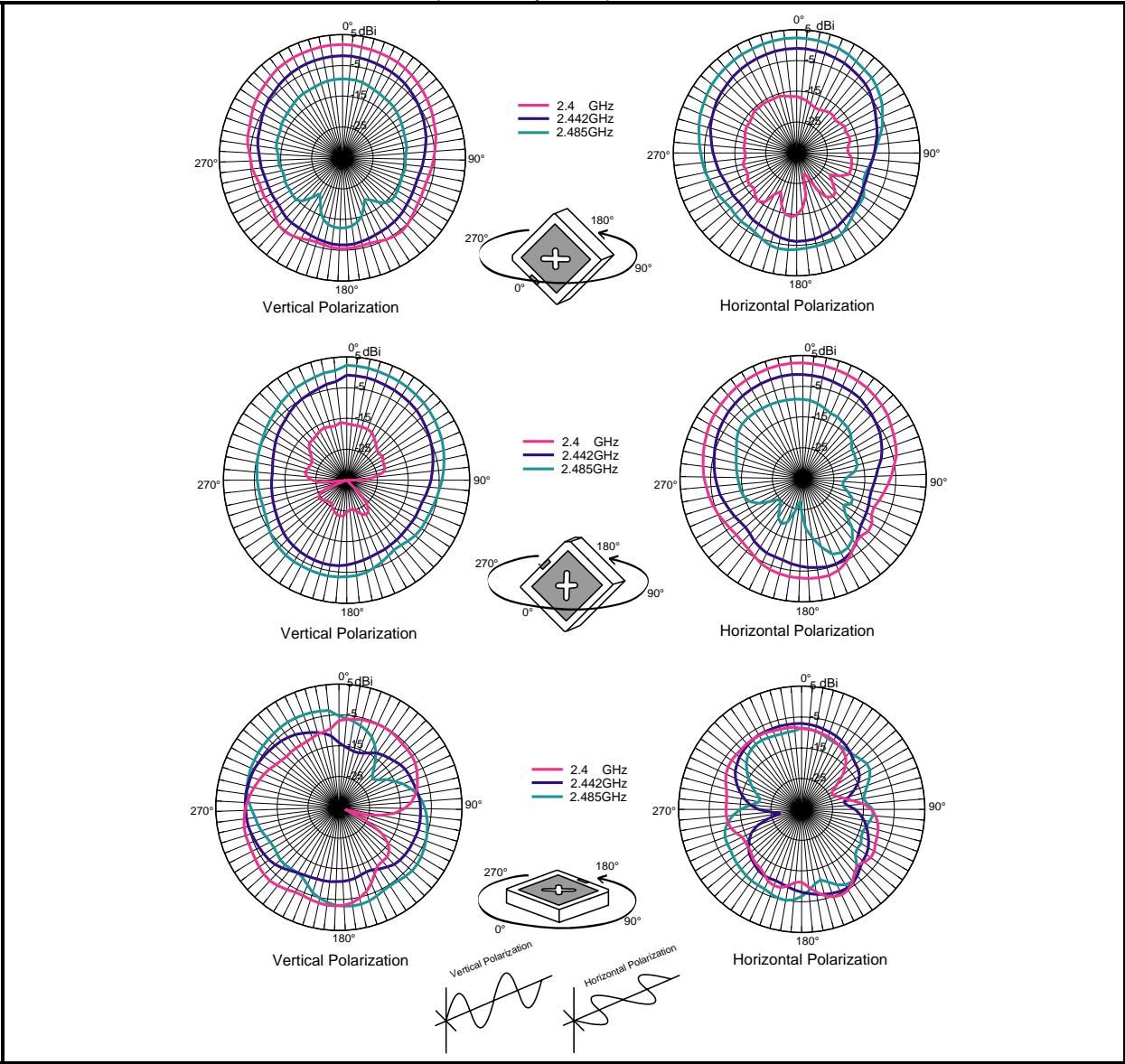

Note: Tested antenna has been soldered on 40x40 mm<sup>2</sup> PCB.

# [ RETURN LOSS&GAIN]

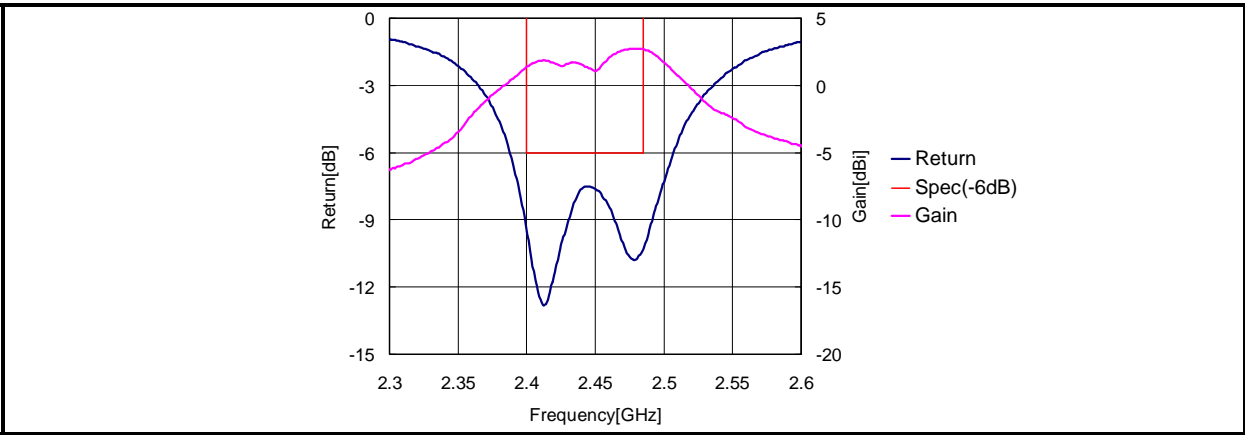

\*Note: This document is PRELIMINARY. All specifications are subject to change without notice and are not guaranteed.

**CHIP MULTILAYER ANTENNA FOR 2.4 GHz W-LAN / Bluetooth**

SAMPLE P/N: **ANT8030-2R4-01**□\*

\*□ is center frequency variation code (A to E).

**[MECHANICAL DIMENSIONS]**

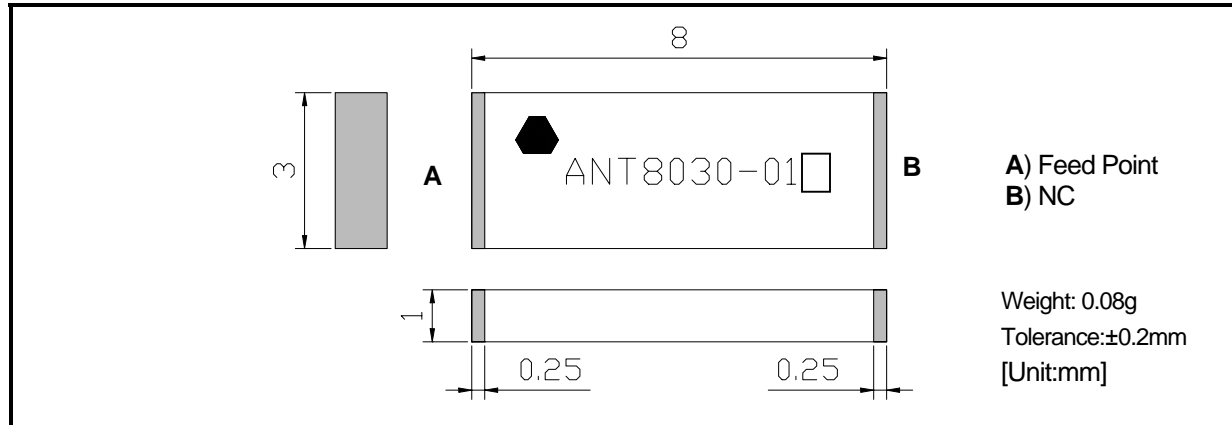

**[ELECTRICAL CHARACTERISTICS]**

| Product name     | ANT8030<br>-2R4-01A | ANT8030<br>-2R4-01B | ANT8030<br>-2R4-01C | ANT8030<br>-2R4-01D | ANT8030<br>-2R4-01E |
|------------------|---------------------|---------------------|---------------------|---------------------|---------------------|
| Center frequency | 2450 MHz            | 2500 MHz            | 2550 MHz            | 2600 MHz            | 2650 MHz            |
| Bandwidth        | 100 MHz             |                     |                     |                     |                     |
| Polarization     | Linear              |                     |                     |                     |                     |
| Antenna Gain     | 2 dBi (Max)         |                     |                     |                     |                     |
| Impedance        | 50 ohm              |                     |                     |                     |                     |
| VSWR             | 2 (Max)             |                     |                     |                     |                     |

|                       |     |     |    |
|-----------------------|-----|-----|----|
| Operating temperature | -30 | +85 | °C |
| Storage temperature   | -40 | +85 | °C |

Note: Please use the 0dBi = -2.15dBd to convert antenna gain expressed in dBd.

**[RECOMMENDED PCB PATTERN]**

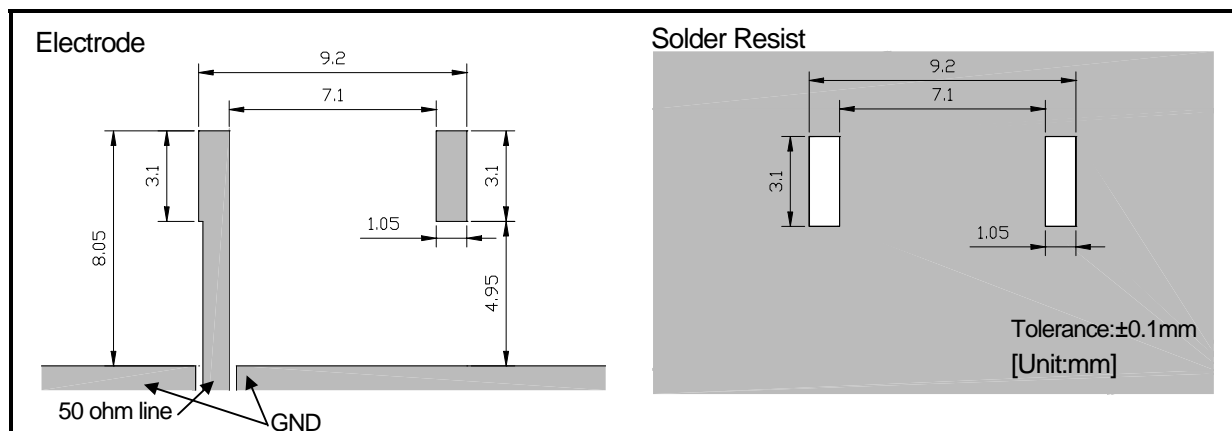

Note: This document is PRELIMINARY. All specifications are subject to change without notice and are not guaranteed.



- Item: ANT8030-2R4-01A
- Standard antenna: Standard dipole (Anritsu)
- Tx antenna: Horn (TECOM)

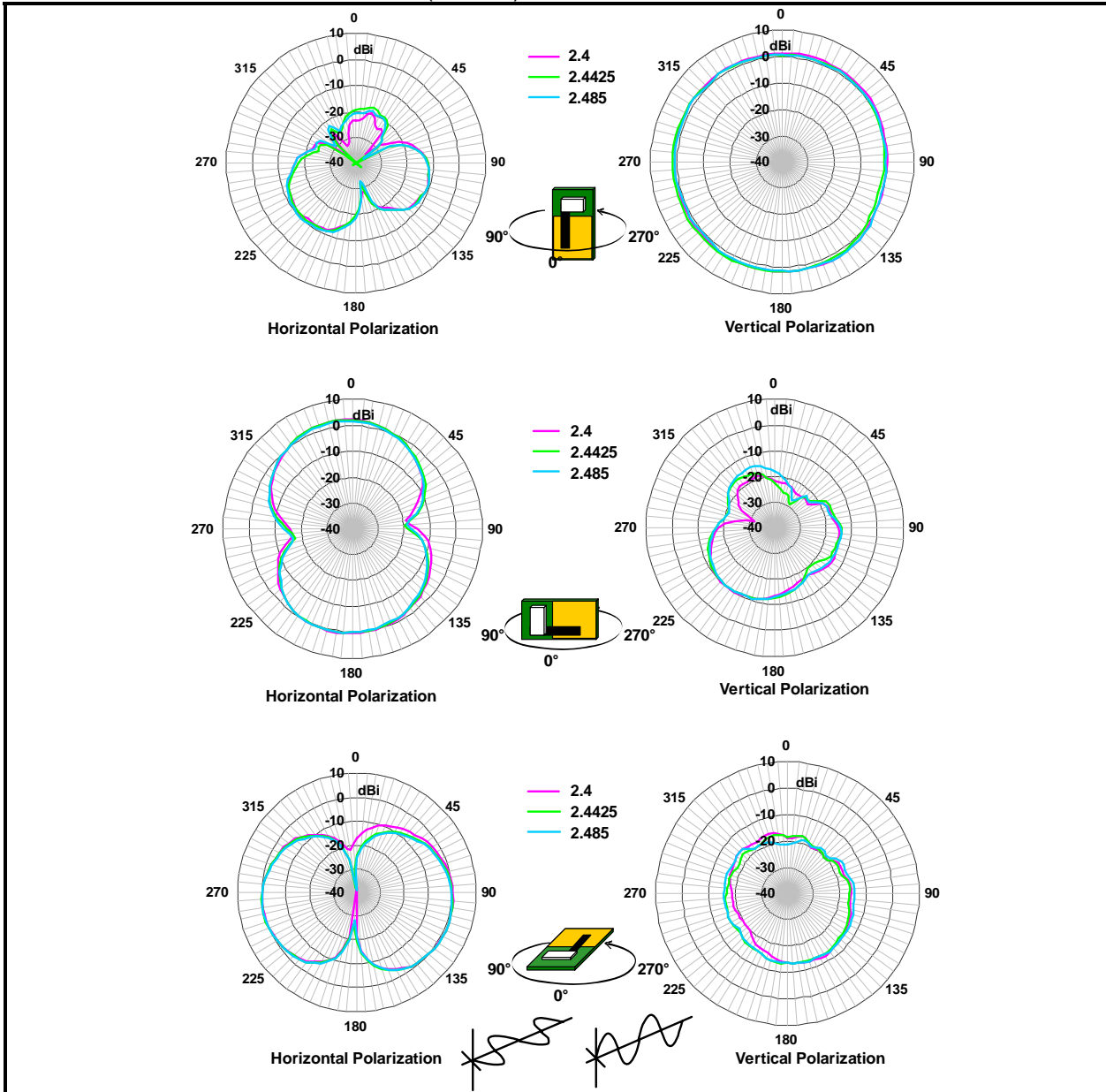

Note: Tested antenna has been soldered on 55x20 mm<sup>2</sup> PCB.

### [ V.S.W.R. ]

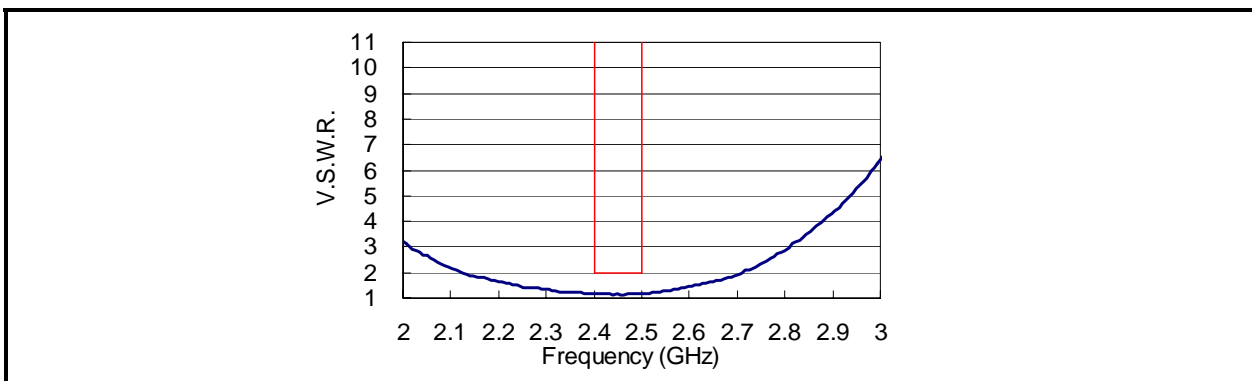

Note: Tested antenna has been soldered on 55x20 mm<sup>2</sup> PCB.

**Note: This document is PRELIMINARY. All specifications are subject to change without notice and are not guaranteed.**