

EZ-OTG™ Programmable USB On-The-Go Host/Peripheral Controller

EZ-OTG Features

- Single-chip programmable USB dual-role (Host/Peripheral) controller with two configurable Serial Interface Engines (SIEs) and two USB ports
- Supports USB OTG protocol
- On-chip 48-MHz 16-bit processor with dynamically switchable clock speed
- Configurable IO block supports a variety of IO options or up to 25 bits of General Purpose IO (GPIO)
- 4K × 16 internal mask ROM contains built-in BIOS that supports a communication-ready state with access to I²C™ EEPROM interface, external ROM, UART, or USB
- 8K × 16 internal RAM for code and data buffering
- 16-bit parallel host port interface (HPI) with DMA/Mailbox data path for an external processor to directly access all on-chip memory and control on-chip SIEs

- Fast serial port supports from 9600 baud to 2.0M baud
- SPI supports both master and slave
- Supports 12 MHz external crystal or clock
- 2.7 V to 3.6 V power supply voltage
- Package option: 48-pin FBGA

Typical Applications

EZ-OTG is a very powerful and flexible dual-role USB controller that supports a wide variety of applications. It is primarily intended to enable USB OTG capability in applications such as:

- Cellular phones
- PDAs and pocket PCs
- Video and digital still cameras
- MP3 players
- Mass storage devices

Logic Block Diagram – CY7C67200

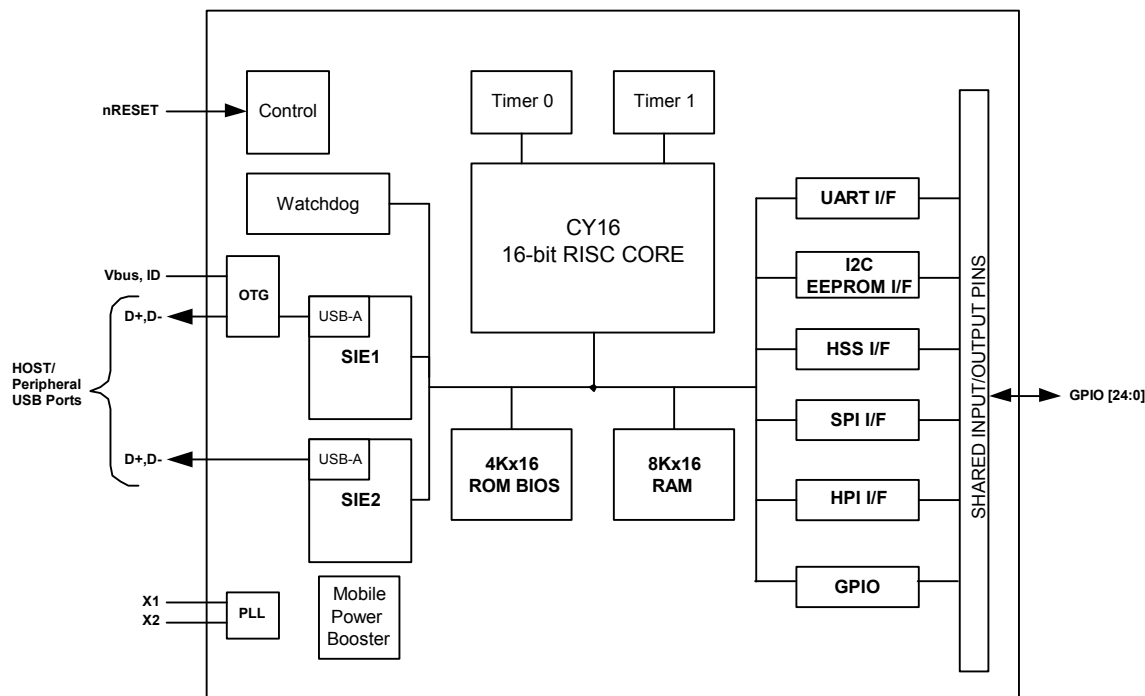

Errata: For information on silicon errata, see "Errata" on page 84. Details include trigger conditions, devices affected, and proposed workaround.

Contents

Introduction	3	HSS Registers	47
Processor Core Functional Overview	3	HPI Registers	53
Processor	3	SPI Registers	57
Clocking	3	UART Registers	65
Memory	3	Pin Diagram	67
Interrupts	3	Pin Descriptions	67
General Timers and Watchdog Timer	3	Absolute Maximum Ratings	69
Power Management	3	Operating Conditions	69
Interface Descriptions	3	Crystal Requirements (XTALIN, XTALOUT)	69
USB Interface	4	DC Characteristics	70
OTG Interface	4	USB Transceiver	71
General Purpose IO Interface	4	AC Timing Characteristics	71
UART Interface	4	Reset Timing	71
I2C EEPROM Interface	5	Clock Timing	72
Serial Peripheral Interface	5	I2C EEPROM Timing	72
High-Speed Serial Interface	5	HPI (Host Port Interface) Read Cycle Timing	74
Host Port Interface (HPI)	6	HSS BYTE Mode Transmit	75
Charge Pump Interface	6	HSS Block Mode Transmit	75
Booster Interface	7	HSS BYTE and BLOCK Mode Receive	75
Crystal Interface	8	Hardware CTS/RTS Handshake	76
Boot Configuration Interface	8	Register Summary	77
Operational Modes	9	Ordering Information	81
Power Savings and Reset Description	10	Ordering Code Definitions	81
Power Savings Mode Description	10	Package Diagram	82
Sleep	10	Acronyms	83
External (Remote) Wakeup Source	10	Document Conventions	83
Power-On Reset (POR) Description	10	Units of Measure	83
Reset Pin	10	Errata	84
USB Reset	10	Part Numbers Affected	84
Memory Map	10	CY7C67200 Qualification Status	84
Mapping	10	CY7C67200 Errata Summary	84
Internal Memory	11	Document History Page	91
Registers	11	Sales, Solutions, and Legal Information	93
Processor Control Registers	11	Worldwide Sales and Design Support	93
Timer Registers	18	Products	93
General USB Registers	20	PSoC@Solutions	93
USB Host Only Registers	22	Cypress Developer Community	93
USB Device Only Registers	30	Technical Support	93
OTG Control Registers	42		
GPIO Registers	43		

Introduction

EZ-OTG™ (CY7C67200) is Cypress Semiconductor's first USB On-The-Go (OTG) host/peripheral controller. EZ-OTG is designed to easily interface to most high-performance CPUs to add USB host functionality. EZ-OTG has its own 16-bit RISC processor to act as a coprocessor or operate in standalone mode. EZ-OTG also has a programmable IO interface block allowing a wide range of interface options.

Processor Core Functional Overview

An overview of the processor core components are presented in this section.

Processor

EZ-OTG has a general purpose 16-bit embedded RISC processor that runs at 48 MHz.

Clocking

EZ-OTG requires a 12 MHz source for clocking. Either an external crystal or TTL-level oscillator may be used. EZ-OTG has an internal PLL that produces a 48 MHz internal clock from the 12 MHz source.

Memory

EZ-OTG has a built-in 4K × 16 masked ROM and an 8K × 16 internal RAM. The masked ROM contains the EZ-OTG BIOS. The internal RAM can be used for program code or data.

Interrupts

EZ-OTG provides 128 interrupt vectors. The first 48 vectors are hardware interrupts and the following 80 vectors are software interrupts.

General Timers and Watchdog Timer

EZ-OTG has two built-in programmable timers and a watchdog timer. All three timers can generate an interrupt to the EZ-OTG.

Power Management

EZ-OTG has one main power-saving mode, Sleep. Sleep mode pauses all operations and provides the lowest power state.

Interface Descriptions

EZ-OTG has a variety of interface options for connectivity, with several interface options available. See [Table 1](#) to understand how the interfaces share pins and can coexist. Below are some general guidelines:

- I2C EEPROM and OTG do not conflict with any interfaces
- HPI is mutually exclusive to HSS, SPI, and UART

Table 1. Interface Options for GPIO Pins

GPIO Pins	HPI	HSS	SPI	UART	I2C	OTG
GPIO31					SCL/SDA	
GPIO30					SCL/SDA	
GPIO29						OTGID
GPIO24	INT					
GPIO23	nRD					
GPIO22	nWR					
GPIO21	nCS					
GPIO20	A1					
GPIO19	A0					
GPIO15	D15	CTS				
GPIO14	D14	RTS				
GPIO13	D13	RXD				
GPIO12	D12	TXD				
GPIO11	D11		MOSI			
GPIO10	D10		SCK			
GPIO9	D9		nSSI			
GPIO8	D8		MISO			
GPIO7	D7			TX		
GPIO6	D6			RX		
GPIO5	D5					
GPIO4	D4					
GPIO3	D3					
GPIO2	D2					
GPIO1	D1					
GPIO0	D0					

USB Interface

EZ-OTG has two built-in Host/Peripheral SIEs that each have a single USB transceiver, meeting the USB 2.0 specification requirements for full and low speed (high speed is not supported). In Host mode, EZ-OTG supports two downstream ports; each supports control, interrupt, bulk, and isochronous transfers. In Peripheral mode, EZ-OTG supports one peripheral port with eight endpoints for each of the two SIEs. Endpoint 0 is dedicated as the control endpoint and only supports control transfers. Endpoints 1 through 7 support Interrupt, bulk (up to 64 bytes per packet), or isochronous transfers (up to 1023 bytes per packet size). EZ-OTG also supports a combination of Host and Peripheral ports simultaneously, as shown in [Table 2](#).

Table 2. USB Port Configuration Options

Port Configurations	Port 1A	Port 2A
OTG	OTG	–
OTG + 1 Host	OTG	Host
OTG + 1 Peripheral	OTG	Peripheral
1 Host + 1 Peripheral	Host	Peripheral
1 Host + 1 Peripheral	Peripheral	Host
2 Hosts	Host	Host
1 Host	Host	–
1 Host	–	Host
2 Peripherals	Peripheral	Peripheral
1 Peripheral	Peripheral	–
1 Peripheral	–	Peripheral

USB Features

- USB 2.0 compatible for full and low speed
- Up to two downstream USB host ports
- Up to two upstream USB peripheral ports
- Configurable endpoint buffers (pointer and length), must reside in internal RAM
- Up to eight available peripheral endpoints (1 control endpoint)
- Supports Control, Interrupt, Bulk, and Isochronous transfers
- Internal DMA channels for each endpoint
- Internal pull up and pull down resistors
- Internal Series termination resistors on USB data lines

USB Pins

Table 3. USB Interface Pins

Pin Name	Pin Number
DM1A	F2
DP1A	E3
DM2A	C2
DP2A	D3

Note

1. **Errata:** The UART is not designed to recognize framing errors. For more information, see the [Errata on page 84](#).

OTG Interface

EZ-OTG has one USB port that is compatible with the USB On-The-Go supplement to the USB 2.0 specification. The USB OTG port has various hardware features to support Session Request Protocol (SRP) and Host Negotiation Protocol (HNP). OTG is only supported on USB PORT 1A.

OTG Features

- Internal Charge Pump to supply and control VBUS
- VBUS Valid Status (above 4.4 V)
- VBUS Status for 2.4 V < VBUS < 0.8 V
- ID Pin Status
- Switchable 2-Kohm internal discharge resistor on VBUS
- Switchable 500-ohm internal pull-up resistor on VBUS
- Individually switchable internal pull-up and pull-down resistors on the USB data lines

OTG Pins

Table 4. OTG Interface Pins

Pin Name	Pin Number
DM1A	F2
DP1A	E3
OTGVBUS	C1
OTGID	F4
CSwitchA	D1
CSwitchB	D2

General Purpose IO Interface

EZ-OTG has up to 25 GPIO signals available. Several other optional interfaces use GPIO pins as well and may reduce the overall number of available GPIOs.

GPIO Description

All Inputs are sampled asynchronously with state changes occurring at a rate of up to two 48 MHz clock cycles. GPIO pins are latched directly into registers, a single flip-flop.

Unused Pin Descriptions

Unused USB pins must be tri-stated with the D+ line pulled high through the internal pull-up resistor and the D– line pulled low through the internal pull-down resistor.

Unused GPIO pins must be configured as outputs and driven low.

UART Interface

EZ-OTG has a built-in UART interface. The UART interface ^[1] supports data rates from 900 to 115.2K baud. It can be used as a development port or for other interface requirements. The UART interface is exposed through GPIO pins.

UART Features

- Supports baud rates of 900 to 115.2K
- 8-N-1

UART Pins

Table 5. UART Interface Pins

Pin Name	Pin Number
TX	B5
RX	B4

I²C EEPROM Interface

EZ-OTG provides a master-only I2C interface for external serial EEPROMs. The serial EEPROM can be used to store application-specific code and data. This I2C interface [2] is only to be used for loading code out of EEPROM, it is not a general I2C interface. The I2C EEPROM interface is a BIOS implementation and is exposed through GPIO pins. Refer to the BIOS documentation for additional details on this interface.

I²C EEPROM Features

- Supports EEPROMs up to 64 KB (512K bit)
- Auto-detection of EEPROM size

I²C EEPROM Pins

Table 6. I²C EEPROM Interface Pins

Pin Name	Pin Number
SMALL EEPROM	
SCK	H3
SDA	F3
LARGE EEPROM	
SCK	F3
SDA	H3

Serial Peripheral Interface

EZ-OTG provides an SPI interface for added connectivity. EZ-OTG may be configured as either an SPI master or SPI slave. The SPI interface can be exposed through GPIO pins or the External Memory port.

SPI Features

- Master or slave mode operation
- DMA block transfer and PIO byte transfer modes
- Full duplex or half duplex data communication
- 8-byte receive FIFO and 8-byte transmit FIFO
- Selectable master SPI clock rates from 250 kHz to 12 MHz
- Selectable master SPI clock phase and polarity

Note

2. **Errata:** If, while the BIOS is loading firmware, the part is reset and at that time the EEPROM is driving the SDA line low, the BIOS will configure the part for co-processor mode instead of standalone mode. For more information, see the [Errata on page 84](#).

- Slave SPI signaling synchronization and filtering
- Slave SPI clock rates up to 2 MHz
- Maskable interrupts for block and byte transfer modes
- Individual bit transfer for non-byte aligned serial communication in PIO mode
- Programmable delay timing for the active/inactive master SPI clock
- Auto or manual control for master mode slave select signal
- Complete access to internal memory

SPI Pins

The SPI port has a few different pin location options as shown in [Table 7](#). The pin location is selectable via the GPIO Control register [0xC006].

Table 7. SPI Interface Pins

Pin Name	Pin Number
nSSI	F6 or C6
SCK	D5
MOSI	D4
MISO	C5

High-Speed Serial Interface

EZ-OTG provides an HSS interface. The HSS interface is a programmable serial connection with baud rate from 9600 baud to 2M baud. The HSS interface supports both byte and block mode operations as well as hardware and software handshaking. Complete control of EZ-OTG can be accomplished through this interface via an extensible API and communication protocol. The HSS interface can be exposed through GPIO pins or the External Memory port.

HSS Features

- 8-bit, no parity code
- Programmable baud rate from 9600 baud to 2M baud
- Selectable 1- or 2-stop bit on transmit
- Programmable intercharacter gap timing for Block Transmit
- 8-byte receive FIFO
- Glitch filter on receive
- Block mode transfer directly to/from EZ-OTG internal memory (DMA transfer)
- Selectable CTS/RTS hardware signal handshake protocol
- Selectable XON/XOFF software handshake protocol
- Programmable Receive interrupt, Block Transfer Done interrupts
- Complete access to internal memory

HSS Pins

Table 8. HSS Interface Pins

Pin Name	Pin Number
CTS	F6
RTS	E4
RX	E5
TX	E6

Host Port Interface (HPI)

EZ-OTG has an HPI interface. The HPI interface provides DMA access to the EZ-OTG internal memory by an external host, plus a bidirectional mailbox register for supporting high-level communication protocols. This port is designed to be the primary high-speed connection to a host processor. Complete control of EZ-OTG can be accomplished through this interface via an extensible API and communication protocol. Other than the hardware communication protocols, a host processor has identical control over EZ-Host whether connecting to the HPI or HSS port. The HPI interface is exposed through GPIO pins.

Note It should be noted that for up to 3 ms after BIOS starts executing, GPIO[24:19] and GPIO[15:8] will be driven as outputs for a test mode. If these pins need to be used as inputs, a series resistor is required (10 ohm to 48 ohm is recommended). Refer to BIOS documentation for addition details. See section "Reset Pin" on page 10.

HPI Features

- 16-bit data bus interface
- 16 MB/s throughput
- Auto-increment of address pointer for fast block mode transfers
- Direct memory access (DMA) to internal memory
- Bidirectional Mailbox register
- Byte Swapping
- Complete access to internal memory
- Complete control of SIEs through HPI
- Dedicated HPI Status register

HPI Pins

Table 9. HPI Interface Pins ^[3, 4]

Pin Name	Pin Number
INT	H4
nRD	G4
nWR	H5
nCS	G5
A1	H6
A0	F5

Notes

3. HPI_INT is for the Outgoing Mailbox Interrupt.
4. HPI strobes are negative logic sampled on rising edge.

Table 9. HPI Interface Pins ^[3, 4] (continued)

Pin Name	Pin Number
D15	F6
D14	E4
D13	E5
D12	E6
D11	D4
D10	D5
D9	C6
D8	C5
D7	B5
D6	B4
D5	C4
D4	B3
D3	A3
D2	C3
D1	A2
D0	B2

The two HPI address pins are used to address one of four possible HPI port registers as shown in Table 10 below.

Table 10. HPI Addressing

HPI A[1:0]	A1	A0
HPI Data	0	0
HPI Mailbox	0	1
HPI Address	1	0
HPI Status	1	1

Charge Pump Interface

VBUS for the USB On-The-Go (OTG) port can be produced by EZ-OTG using its built-in charge pump and some external components. The circuit connections should look similar to Figure 1 below.

Figure 1. Charge Pump

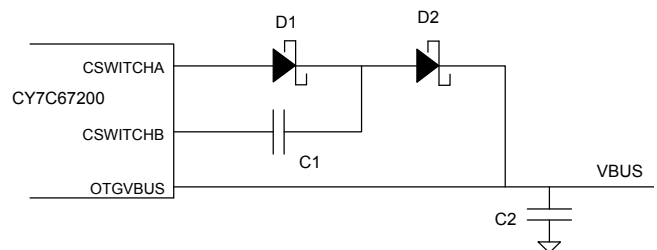

Component details:

- D1 and D2: Schottky diodes with a current rating greater than 60 mA.
- C1: Ceramic capacitor with a capacitance of 0.1 μ F.
- C2: Capacitor value must be no more that 6.5 μ F since that is the maximum capacitance allowed by the USB OTG specification for a dual-role device. The minimum value of C2 is 1 μ F. There are no restrictions on the type of capacitor for C2.

If the VBUS charge pump circuit is not to be used, CSWITCHA, CSWITCHB, and OTGVBUS can be left unconnected.

Charge Pump Features

- Meets OTG Supplement Requirements, see Table 41, "DC Characteristics: Charge Pump," on page 70.

Charge Pump Pins

Table 11. Charge Pump Interface Pins

Pin Name	Pin Number
OTGVBUS	C1
CSwitchA	D1
CSwitchB	D2

Booster Interface

EZ-OTG has an on-chip power booster circuit for use with power supplies that range between 2.7 V and 3.6 V. The booster circuit boosts the power to 3.3 V nominal to supply power for the entire chip. The booster circuit requires an external inductor, diode, and capacitor. During power down mode, the circuit is disabled to save power. Figure 2 shows how to connect the booster circuit.

Figure 2. Power Supply Connection With Booster

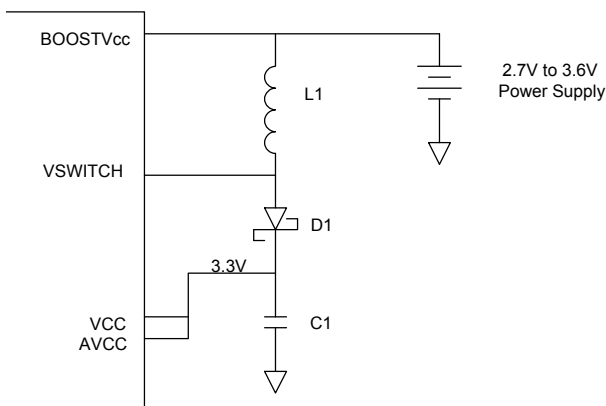

Component details:

- L1: Inductor with inductance of 10 μ H and a current rating of at least 250 mA
- D1: Schottky diode with a current rating of at least 250 mA
- C1: Tantalum or ceramic capacitor with a capacitance of at least 2.2 μ F

Figure 3 shows how to connect the power supply when the booster circuit is not being used.

Figure 3. Power Supply Connection Without Booster

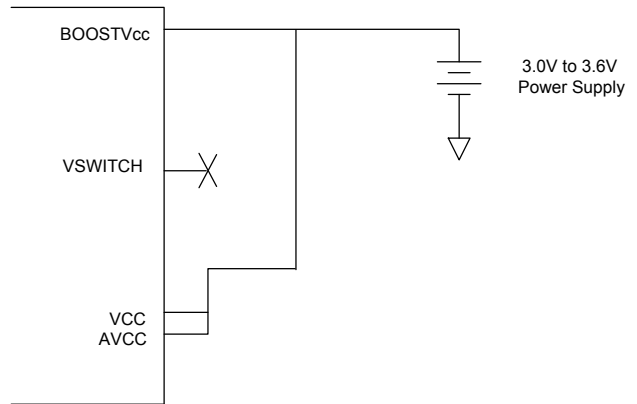

Booster Pins

Table 12. Charge Pump Interface Pins

Pin Name	Pin Number
BOOSTVcc	F1
VSWITCH	E2

Crystal Interface

The recommended crystal circuit to be used with EZ-OTG is shown in Figure 4. If an oscillator is used instead of a crystal circuit, connect it to XTALIN and leave XTALOUT unconnected. For further information on the crystal requirements, see Table 39, “Crystal Requirements,” on page 69.

Figure 4. Crystal Interface

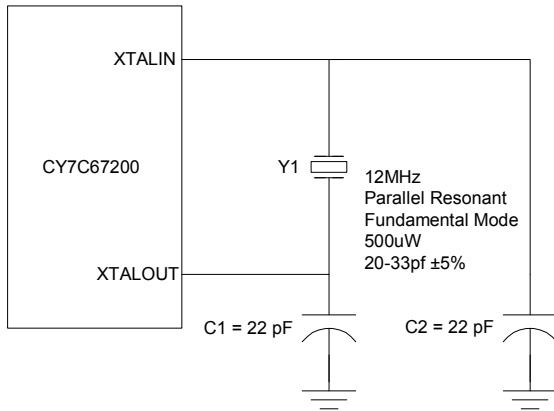

Crystal Pins

Table 13. Crystal Pins

Pin Name	Pin Number
XTALIN	G3
XTALOUT	G2

Boot Configuration Interface

EZ-OTG can boot into any one of four modes. The mode it boots into is determined by the TTL voltage level of GPIO[31:30] at the time nRESET is deasserted. Table 14 shows the different boot pin combinations possible. After a reset pin event occurs, the BIOS bootup procedure executes for up to 3 ms. GPIO[31:30] are sampled by the BIOS during bootup only. After bootup these pins are available to the application as GPIOs.

Table 14. Boot Configuration Interface

GPIO31 (Pin 39)	GPIO30 (Pin 40)	Boot Mode
0	0	Host Port Interface (HPI)
0	1	High Speed Serial (HSS)
1	0	Serial Peripheral Interface (SPI, slave mode)
1	1	I2C EEPROM (Standalone Mode)

GPIO[31:30] must be pulled high or low, as needed, using resistors tied to V_{CC} or GND with resistor values between 5K ohm and 15K ohm. GPIO[31:30] must not be tied directly to V_{CC} or GND. Note that in Standalone mode, the pull ups on those two pins are used for the serial I2C EEPROM (if implemented). The resistors used for these pull ups must conform to the serial EEPROM manufacturer's requirements.

If any mode other than standalone is chosen, EZ-OTG will be in coprocessor mode. The device will power up with the appropriate communication interface enabled according to its boot pins and wait idle until a coprocessor communicates with it. See the BIOS documentation for greater detail on the boot process.

Operational Modes

There are two modes of operation: Coprocessor and Stand-alone.

Coprocessor Mode

EZ-OTG can act as a coprocessor to an external host processor. In this mode, an external host processor drives EZ-OTG and is the main processor rather than EZ-OTG's own 16-bit internal CPU. An external host processor may interface to EZ-OTG through one of the following three interfaces in coprocessor mode:

- HPI mode, a 16-bit parallel interface with up to 16 MBytes transfer rate
- HSS mode, a serial interface with up to 2M baud transfer rate
- SPI mode, a serial interface with up to 2 Mbits/s transfer rate.

At bootup GPIO[31:30] determine which of these three interfaces are used for coprocessor mode. Refer to Table 14 for details. Bootloading begins from the selected interface after POR + 3 ms of BIOS bootup.

Standalone Mode

In standalone mode, there is no external processor connected to EZ-OTG. Instead, EZ-OTG's own internal 16-bit CPU is the main processor and firmware is typically downloaded from an EEPROM. Optionally, firmware may also be downloaded via USB. Refer to Table 14 for booting into standalone mode.

After booting into standalone mode (GPIO[31:30] = '11'), the following pins are affected:

- GPIO[31:30] are configured as output pins to examine the EEPROM contents.
- GPIO[28:27] are enabled for debug UART mode.
- GPIO[29] is configured as OTGID for OTG applications on PORT1A.
 - If OTGID is logic 1 then PORT1A (OTG) is configured as a USB peripheral.
 - If OTGID is logic 0 then PORT1A (OTG) is configured as a USB host.
- Ports 1B, 2A, and 2B default as USB peripheral ports.
- All other pins remain INPUT pins.

Minimum Hardware Requirements for Standalone Mode – Peripheral Only

Figure 5. Minimum Standalone Hardware Configuration – Peripheral Only

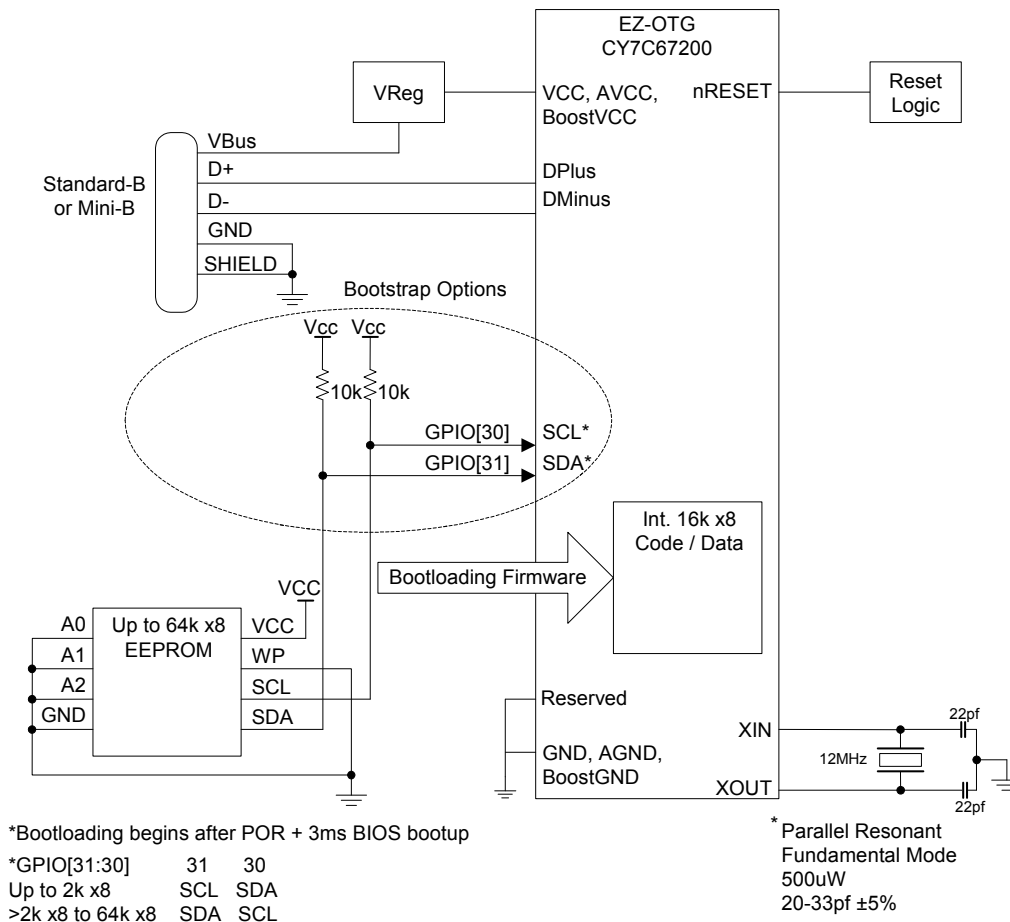

Power Savings and Reset Description

The EZ-OTG modes and reset conditions are described in this section.

Power Savings Mode Description

EZ-OTG has one main power savings mode, Sleep. For detailed information on Sleep mode; See section “Sleep”.

Sleep mode is used for USB applications to support USB suspend and non USB applications as the main chip power down mode.

In addition, EZ-OTG is capable of slowing down the CPU clock speed through the CPU Speed register [0xC008] without affecting other peripheral timing. Reducing the CPU clock speed from 48 MHz to 24 MHz reduces the overall current draw by around 8 mA while reducing it from 48 MHz to 3 MHz reduces the overall current draw by approximately 15 mA.

Sleep

Sleep mode is the main chip power down mode and is also used for USB suspend. Sleep mode is entered by setting the Sleep Enable (bit 1) of the Power Control register [0xC00A]. During Sleep mode (USB Suspend) the following events and states are true:

- GPIO pins maintain their configuration during sleep (in suspend).
- External Memory Address pins are driven low.
- XTALOUT is turned off.
- Internal PLL is turned off.
- Firmware must disable the charge pump (OTG Control register [0xC098]) causing OTGVBUS to drop below 0.2 V. Otherwise OTGVBUS will only drop to $V_{CC} - (2 \text{ schottky diode drops})$.
- Booster circuit is turned off.
- USB transceivers is turned off.
- CPU suspends until a programmable wakeup event.

External (Remote) Wakeup Source

There are several possible events available to wake EZ-OTG from Sleep mode as shown in Table 15. These may also be used as remote wakeup options for USB applications. See section “Power Control Register [0xC00A] [R/W]” on page 15.

Upon wakeup, code begins executing within 200 ms, the time it takes the PLL to stabilize.

Table 15. wakeup Sources^[5, 6]

Wakeup Source (if enabled)	Event
USB Resume	D+/D– Signaling
OTGVBUS	Level
OTGID	Any Edge
HPI	Read
HSS	Read
SPI	Read
IRQ0 (GPIO 24)	Any Edge

Power-On Reset (POR) Description

The length of the power-on-reset event can be defined by (V_{CC} ramp to valid) + (Crystal start up). A typical application might utilize a 12-ms power-on-reset event = ~7 ms + ~5 ms, respectively.

Reset Pin

The Reset pin is active low and requires a minimum pulse duration of sixteen 12-MHz clock cycles (1.3 ms). A reset event restores all registers to their default POR settings. Code execution then begins 200 ms later at 0xFF00 with an immediate jump to 0xE000, the start of BIOS.

Note It should be noted that for up to 3 ms after BIOS starts executing, GPIO[24:19] and GPIO[15:8] will be driven as outputs for a test mode. If these pins need to be used as inputs, a series resistor is required (10 ohm to 48 ohm is recommended). Refer to BIOS documentation for addition details.

USB Reset

A USB Reset affects registers 0xC090 and 0xC0B0, all other registers remain unchanged.

Memory Map

Memory map information is presented in this section.

Mapping

The EZ-OTG has just over 24 KB of addressable memory mapped from 0x0000 to 0xFFFF. This 24 KB contains both program and data space and is byte addressable. Figure 6. shows the various memory region address locations.

Notes

5. Read data will be discarded (dummy data).
6. HPI_INT will assert on a USB Resume.registers

Internal Memory

Of the internal memory, 15 KB is allocated for user's program and data code. The lower memory space from 0x0000 to 0x04A2 is reserved for interrupt vectors, general purpose registers, USB control registers, the stack, and other BIOS variables. The upper internal memory space contains EZ-OTG control registers from 0xC000 to 0xC0FF and the BIOS ROM itself from 0xE000 to 0xFFFF. For more information on the reserved lower memory or the BIOS ROM, refer to the Programmers documentation and the BIOS documentation.

During development with the EZ-OTG toolset, the lower area of User's space (0x04A4 to 0x1000) should be left available to load the GDB stub. The GDB stub is required to allow the toolset debug access into EZ-OTG.

Figure 6. Memory Map

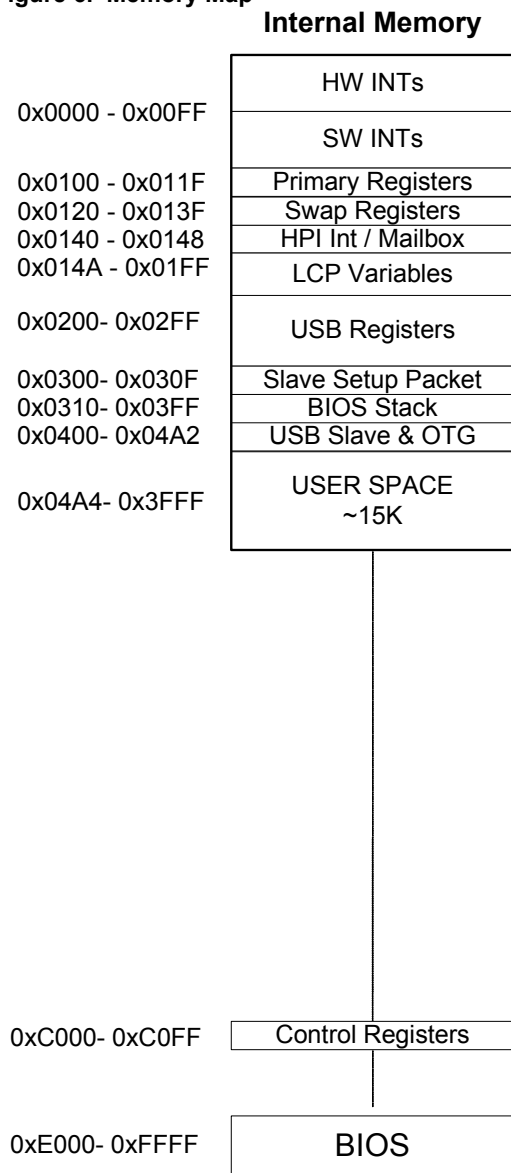

Registers

Some registers have different functions for a read vs. a write access or USB host vs. USB device mode. Therefore, registers of this type have multiple definitions for the same address.

The default register values listed in this data sheet may be altered to some other value during BIOS initialization. Refer to the BIOS documentation for Register initialization information.

Processor Control Registers

There are eight registers dedicated to general processor control. Each of these registers is covered in this section and is summarized in Table 16.

Table 16. Processor Control Registers

Register Name	Address	R/W
CPU Flags Register	0xC000	R
Register Bank Register	0xC002	R/W
Hardware Revision Register	0xC004	R
CPU Speed Register	0xC008	R/W
Power Control Register	0xC00A	R/W
Interrupt Enable Register	0xC00E	R/W
Breakpoint Register	0xC014	R/W
USB Diagnostic Register	0xC03C	W

CPU Flags Register [0xC000] [R]

Figure 7. CPU Flags Register

Bit #	15	14	13	12	11	10	9	8
Field	Reserved...							
Read/Write	–	–	–	–	–	–	–	–
Default	0	0	0	0	0	0	0	0

Bit #	7	6	5	4	3	2	1	0
Field	...Reserved			Global Interrupt Enable	Negative Flag	Overflow Flag	Carry Flag	Zero Flag
Read/Write	–	–	–	R	R	R	R	R
Default	0	0	0	X	X	X	X	X

Register Description

The CPU Flags register is a read only register that gives processor flags status.

Global Interrupt Enable (Bit 4)

The Global Interrupt Enable bit indicates if the Global Interrupts are enabled.

- 1: Enabled
- 0: Disabled

Negative Flag (Bit 3)

The Negative Flag bit indicates if an arithmetic operation results in a negative answer.

- 1: MS result bit is '1'
- 0: MS result bit is not '1'

Overflow Flag (Bit 2)

The Overflow Flag bit indicates if an overflow condition has occurred. An overflow condition can occur if an arithmetic result

was either larger than the destination operand size (for addition) or smaller than the destination operand should allow for subtraction.

- 1: Overflow occurred
- 0: Overflow did not occur

Carry Flag (Bit 1)

The Carry Flag bit indicates if an arithmetic operation resulted in a carry for addition, or borrow for subtraction.

- 1: Carry/Borrow occurred
- 0: Carry/Borrow did not occur

Zero Flag (Bit 0)

The Zero Flag bit indicates if an instruction execution resulted in a '0'.

- 1: Zero occurred
- 0: Zero did not occur

Bank Register [0xC002] [R/W]

Figure 8. Bank Register

Bit #	15	14	13	12	11	10	9	8
Field	Address...							
Read/Write	R/W	R/W	R/W	R/W	R/W	R/W	R/W	R/W
Default	0	0	0	0	0	0	0	1

Bit #	7	6	5	4	3	2	1	0
Field	...Address			Reserved				
Read/Write	R/W	R/W	R/W	–	–	–	–	–
Default	0	0	0	X	X	X	X	X

Register Description

The Bank register maps registers R0–R15 into RAM. The eleven MSBs of this register are used as a base address for registers R0–R15. A register address is automatically generated by:

1. Shifting the four LSBs of the register address left by 1
2. ORing the four shifted bits of the register address with the 12 MSBs of the Bank Register
3. Forcing the LSB to zero

For example, if the Bank register is left at its default value of 0x0100, and R2 is read, then the physical address 0x0102 will be read. See Table 17 for details.

Table 17. Bank Register Example

Register	Hex Value	Binary Value
Bank	0x0100	0000 0001 0000 0000
R14	0x000E << 1 = 0x001C	0000 0000 0001 1100
RAM Location	0x011C	0000 0001 0001 1100

Address (Bits [15:4])

The Address field is used as a base address for all register addresses to start from.

Reserved

All reserved bits must be written as '0'.

Hardware Revision Register [0xC004] [R]

Figure 9. Revision Register

Bit #	15	14	13	12	11	10	9	8
Field	Revision...							
Read/Write	R	R	R	R	R	R	R	R
Default	X	X	X	X	X	X	X	X

Bit #	7	6	5	4	3	2	1	0
Field	...Revision							
Read/Write	R	R	R	R	R	R	R	R
Default	X	X	X	X	X	X	X	X

Register Description

The Hardware Revision register is a read-only register that indicates the silicon revision number. The first silicon revision is represented by 0x0101. This number is increased by one for each new silicon revision.

Revision (Bits [15:0])

The Revision field contains the silicon revision number.

CPU Speed Register [0xC008] [R/W]

Figure 10. CPU Speed Register

Bit #	15	14	13	12	11	10	9	8
Field	Reserved...							
Read/Write	-	-	-	-	-	-	-	-
Default	0	0	0	0	0	0	0	0

Bit #	7	6	5	4	3	2	1	0
Field	...Reserved				CPU Speed			
Read/Write	-	-	-	-	R/W	R/W	R/W	R/W
Default	0	0	0	0	1	1	1	1

Register Description

The CPU Speed register allows the processor to operate at a user selected speed. This register only affects the CPU; all other peripheral timing is still based on the 48-MHz system clock (unless otherwise noted).

CPU Speed (Bits[3:0])

The CPU Speed field is a divisor that selects the operating speed of the processor as defined in [Table 18](#).

Table 18. CPU Speed Definition

CPU Speed [3:0]	Processor Speed
0000	48 MHz/1
0001	48 MHz/2
0010	48 MHz/3
0011	48 MHz/4
0100	48 MHz/5
0101	48 MHz/6
0110	48 MHz/7
0111	48 MHz/8
1000	48 MHz/9
1001	48 MHz/10
1010	48 MHz/11
1011	48 MHz/12
1100	48 MHz/13
1101	48 MHz/14
1110	48 MHz/15
1111	48 MHz/16

Reserved

All reserved bits must be written as '0'.

Power Control Register [0xC00A] [R/W]

Figure 11. Power Control Register

Bit #	15	14	13	12	11	10	9	8
Field	Reserved	Host/Device 2 Wake Enable	Reserved	Host/Device 1 Wake Enable	OTG Wake Enable	Reserved	HSS Wake Enable	SPI Wake Enable
Read/Write	–	R/W	–	R/W	R/W	–	R/W	R/W
Default	0	0	0	0	0	0	0	0

Bit #	7	6	5	4	3	2	1	0
Field	HPI Wake Enable	Reserved		GPI Wake Enable	Reserved	Boost 3V OK	Sleep Enable	Halt Enable
Read/Write	R/W	–	–	R/W	–	R	R/W	R/W
Default	0	0	0	0	0	0	0	0

Register Description

The Power Control register controls the power-down and wakeup options. Either the sleep mode or the halt mode options can be selected. All other writable bits in this register can be used as a wakeup source while in sleep mode.

Host/Device 2 Wake Enable (Bit 14)

The Host/Device 2 Wake Enable bit enables or disables a wakeup condition to occur on an Host/Device 2 transition. This wake up from the SIE port does not cause an interrupt to the on-chip CPU.

- 1: Enable wakeup on Host/Device 2 transition.
- 0: Disable wakeup on Host/Device 2 transition.

Host/Device 1 Wake Enable (Bit 12)

The Host/Device 1 Wake Enable bit enables or disables a wakeup condition to occur on an Host/Device 1 transition. This wakeup from the SIE port does not cause an interrupt to the on-chip CPU.

- 1: Enable wakeup on Host/Device 1 transition
- 0: Disable wakeup on Host/Device 1 transition

OTG Wake Enable (Bit 11)

The OTG Wake Enable bit enables or disables a wakeup condition to occur on either an OTG VBUS_Valid or OTG ID transition (IRQ20).

- 1: Enable wakeup on OTG VBUS valid or OTG ID transition
- 0: Disable wakeup on OTG VBUS valid or OTG ID transition

HSS Wake Enable (Bit 9)

The HSS Wake Enable bit enables or disables a wakeup condition to occur on an HSS Rx serial input transition. The processor may take several hundreds of microseconds before being operational after wakeup. Therefore, the incoming data byte that causes the wakeup will be discarded.

- 1: Enable wakeup on HSS Rx serial input transition
- 0: Disable wakeup on HSS Rx serial input transition

SPI Wake Enable (Bit 8)

The SPI Wake Enable bit enables or disables a wakeup condition to occur on a falling SPI_nSS input transition. The processor may take several hundreds of microseconds before being operational after wakeup. Therefore, the incoming data byte that causes the wakeup will be discarded.

- 1: Enable wakeup on falling SPI nSS input transition
- 0: Disable SPI_nSS interrupt

HPI Wake Enable (Bit 7)

The HPI Wake Enable bit enables or disables a wakeup condition to occur on an HPI interface read.

- 1: Enable wakeup on HPI interface read
- 0: Disable wakeup on HPI interface read

GPI Wake Enable (Bit 4)

The GPI Wake Enable bit enables or disables a wakeup condition to occur on a GPIO(25:24) transition.

- 1: Enable wakeup on GPIO(25:24) transition
- 0: Disable wakeup on GPIO(25:24) transition

Boost 3V OK (Bit 2)

The Boost 3V OK bit is a read only bit that returns the status of the OTG Boost circuit.

- 1: Boost circuit not ok and internal voltage rails are below 3.0 V
- 0: Boost circuit ok and internal voltage rails are at or above 3.0 V

Sleep Enable (Bit 1)

Setting this bit to '1' immediately initiates SLEEP mode. While in SLEEP mode, the entire chip is paused achieving the lowest standby power state. All operations are paused, the internal clock is stopped, the booster circuit and OTG VBUS charge pump are all powered down, and the USB transceivers are powered down. All counters and timers are paused but will retain their values. SLEEP mode exits by any activity selected in this register. When SLEEP mode ends, instruction execution resumes within 0.5 ms.

- 1: Enable Sleep Mode
- 0: No Function

Halt Enable (Bit 0)

Setting this bit to '1' immediately initiates HALT mode. While in HALT mode, only the CPU is stopped. The internal clock still runs and all peripherals still operate, including the USB engines. The power savings using HALT in most cases will be minimal, but in applications that are very CPU intensive the incremental savings may provide some benefit.

The HALT state is exited when any enabled interrupt is triggered. Upon exiting the HALT state, one or two instructions immediately following the HALT instruction may be executed before the

waking interrupt is serviced (you may want to follow the HALT instruction with two NOPs).

1: Enable Halt Mode

0: No Function

Reserved

All reserved bits must be written as '0'.

Interrupt Enable Register [0xC00E] [R/W]

Figure 12. Interrupt Enable Register [7]

Bit #	15	14	13	12	11	10	9	8
Field	Reserved			OTG Interrupt Enable	SPI Interrupt Enable	Reserved	Host/Device 2 Interrupt Enable	Host/Device 1 Interrupt Enable
Read/Write	–	–	–	R/W	R/W	–	R/W	R/W
Default	0	0	0	0	0	0	0	0

Bit #	7	6	5	4	3	2	1	0
Field	HSS Interrupt Enable	In Mailbox Interrupt Enable	Out Mailbox Interrupt Enable	Reserved	UART Interrupt Enable	GPIO Interrupt Enable	Timer 1 Interrupt Enable	Timer 0 Interrupt Enable
Read/Write	R/W	R/W	R/W	–	R/W	R/W	R/W	R/W
Default	0	0	0	1	0	0	0	0

Register Description

The Interrupt Enable Register allows control of the hardware interrupt vectors.

OTG Interrupt Enable (Bit 12)

The OTG Interrupt Enable bit enables or disables the OTG ID/OTG4.4 V Valid hardware interrupt.

1: Enable OTG interrupt

0: Disable OTG interrupt

SPI Interrupt Enable (Bit 11)

The SPI Interrupt Enable bit enables or disables the following three SPI hardware interrupts: SPI TX, SPI RX, and SPI DMA Block Done.

1: Enable SPI interrupt

0: Disable SPI interrupt

Host/Device 2 Interrupt Enable (Bit 9)

The Host/Device 2 Interrupt Enable bit enables or disables all of the following Host/Device 2 hardware interrupts: Host 2 USB Done, Host 2 USB SOF/EOP, Host 2 WakeUp/Insert/Remove, Device 2 Reset, Device 2 SOF/EOP or WakeUp from USB, Device 2 Endpoint n.

1: Enable Host 2 and Device 2 interrupt

0: Disable Host 2 and Device 2 interrupt

Host/Device 1 Interrupt Enable (Bit 8)

The Host/Device 1 Interrupt Enable bit enables or disables all of the following Host/Device 1 hardware interrupts: Host 1 USB Done, Host 1 USB SOF/EOP, Host 1 WakeUp/Insert/Remove, Device 1 Reset, Device 1 SOF/EOP or WakeUp from USB, Device 1 Endpoint n.

1: Enable Host 1 and Device 1 interrupt

0: Disable Host 1 and Device 1 interrupt

HSS Interrupt Enable (Bit 7)

The HSS Interrupt Enable bit enables or disables the following High-speed Serial Interface hardware interrupts: HSS Block Done, and HSS RX Full.

1: Enable HSS interrupt

0: Disable HSS interrupt

In Mailbox Interrupt Enable (Bit 6)

The In Mailbox Interrupt Enable bit enables or disables the HPI: Incoming Mailbox hardware interrupt.

1: Enable MBXI interrupt

0: Disable MBXI interrupt

Out Mailbox Interrupt Enable (Bit 5)

The Out Mailbox Interrupt Enable bit enables or disables the HPI: Outgoing Mailbox hardware interrupt.

1: Enable MBXO interrupt

0: Disable MBXO interrupt

Note

7. **Errata:** Host/Device 1 SIE events will still trigger an interrupt when only the Host/Device 2 SIE Interrupt Enable is set and vice versa. For more information, see the [Errata on page 84](#).

UART Interrupt Enable (Bit 3)

The UART Interrupt Enable bit enables or disables the following UART hardware interrupts: UART TX and UART RX.

- 1: Enable UART interrupt
- 0: Disable UART interrupt

GPIO Interrupt Enable (Bit 2)

The GPIO Interrupt Enable bit enables or disables the General Purpose IO Pins Interrupt (See the GPIO Control Register). When GPIO bit is reset, all pending GPIO interrupts are also cleared.

- 1: Enable GPIO interrupt
- 0: Disable GPIO interrupt

Timer 1 Interrupt Enable (Bit 1)

The Timer 1 Interrupt Enable bit enables or disables the Timer1 Interrupt Enable. When this bit is reset, all pending Timer 1 interrupts are cleared.

- 1: Enable TM1 interrupt
- 0: Disable TM1 interrupt

Timer 0 Interrupt Enable (Bit 0)

The Timer 0 Interrupt Enable bit enables or disables the Timer0 Interrupt Enable. When this bit is reset, all pending Timer 0 interrupts are cleared.

- 1: Enable TM0 interrupt
- 0: Disable TM0 interrupt

Reserved

All reserved bits must be written as '0'.

Breakpoint Register [0xC014] [R/W]

Figure 13. Breakpoint Register

Bit #	15	14	13	12	11	10	9	8
Field	Address...							
Read/Write	R/W	R/W	R/W	R/W	R/W	R/W	R/W	R/W
Default	0	0	0	0	0	0	0	0

Bit #	7	6	5	4	3	2	1	0
Field	...Address							
Read/Write	R/W	R/W	R/W	R/W	R/W	R/W	R/W	R/W
Default	0	0	0	0	0	0	0	0

Register Description

The Breakpoint Register holds the breakpoint address. When the program counter match this address, the INT127 interrupt occurs. To clear this interrupt, a zero value must be written to this register.

Address (Bits [15:0])

The Address field is a 16-bit field containing the breakpoint address.

USB Diagnostic Register [0xC03C] [R/W]

Figure 14. USB Diagnostic Register

Bit #	15	14	13	12	11	10	9	8
Field	Reserved	Port 2A Diagnostic Enable	Reserved	Port 1A Diagnostic Enable	Reserved...			
Read/Write	-	R/W	-	R/W	-	-	-	-
Default	0	0	0	0	0	0	0	0

Bit #	7	6	5	4	3	2	1	0
Field	...Reserved	Pull-down Enable	LS Pull-up Enable	FS Pull-up Enable	Reserved	Force Select		
Read/Write	-	R/W	R/W	R/W	-	R/W	R/W	R/W
Default	0	0	0	0	0	0	0	0

Register Description

The USB Diagnostic Register provides control of diagnostic modes. It is intended for use by device characterization tests, not for normal operations. This register is Read/Write by the on-chip CPU but is write-only via the HPI port.

Port 2A Diagnostic Enable (Bit 15)

The Port 2A Diagnostic Enable bit enables or disables Port 2A for the test conditions selected in this register.

1: Apply any of the following enabled test conditions: J/K, DCK, SE0, RSF, RSL, PRD

0: Do not apply test conditions

Port 1A Diagnostic Enable (Bit 12)

The Port 1A Diagnostic Enable bit enables or disables Port 1A for the test conditions selected in this register.

1: Apply any of the following enabled test conditions: J/K, DCK, SE0, RSF, RSL, PRD

0: Do not apply test conditions

Pull-down Enable (Bit 6)

The Pull-down Enable bit enables or disables full-speed pull-down resistors (pull down on both D+ and D-) for testing.

1: Enable pull-down resistors on both D+ and D-

0: Disable pull-down resistors on both D+ and D-

LS Pull-up Enable (Bit 5)

The LS Pull-up Enable bit enables or disables a low-speed pull-up resistor (pull up on D-) for testing.

1: Enable low-speed pull-up resistor on D-

0: Pull-up resistor is not connected on D-

FS Pull-up Enable (Bit 4)

The FS Pull-up Enable bit enables or disables a full-speed pull-up resistor (pull up on D+) for testing.

1: Enable full-speed pull-up resistor on D+

0: Pull-up resistor is not connected on D+

Force Select (Bits [2:0])

The Force Select field bit selects several different test condition states on the data lines (D+/D-). See Table 19 for details.

Table 19. Force Select Definition

Force Select [2:0]	Data Line State
1xx	Assert SE0
01x	Toggle JK
001	Assert J
000	Assert K

Reserved

All reserved bits must be written as '0'.

Timer Registers

There are three registers dedicated to timer operations. Each of these registers are discussed in this section and are summarized in Table 20.

Table 20. Timer Registers

Register Name	Address	R/W
Watchdog Timer Register	0xC00C	R/W
Timer 0 Register	0xC010	R/W
Timer 1 Register	0xC012	R/W

Watchdog Timer Register [0xC00C] [R/W]

Figure 15. Watchdog Timer Register

Bit #	15	14	13	12	11	10	9	8
Field	Reserved...							
Read/Write	R/W	R/W	R/W	R/W	R/W	R/W	R/W	R/W
Default	0	0	0	0	0	0	0	0

Bit #	7	6	5	4	3	2	1	0
Field	...Reserved		Timeout Flag	Period Select		Lock Enable	WDT Enable	Reset Strobe
Read/Write	R/W	R/W	R/W	R/W	R/W	R/W	R/W	W
Default	0	0	0	0	0	0	0	0

Register Description

The Watchdog Timer register provides status and control over the Watchdog timer. The Watchdog timer can also interrupt the processor.

Timeout Flag (Bit 5)

The Timeout Flag bit indicates if the Watchdog timer has expired. The processor can read this bit after exiting a reset to determine if a Watchdog timeout occurred. This bit is cleared on the next external hardware reset.

- 1: Watchdog timer expired
- 0: Watchdog timer did not expire

Period Select (Bits [4:3])

The Period Select field is defined in Table 21. If this time expires before the Reset Strobe bit is set, the internal processor is reset.

Table 21. Period Select Definition

Period Select[4:3]	WDT Period Value
00	1.4 ms
01	5.5 ms
10	22.0 ms
11	66.0 ms

Lock Enable (Bit 2)

The Lock Enable bit does not allow any writes to this register until a reset. In doing so the Watchdog timer can be set up and enabled permanently so that it can only be cleared on reset (the WDT Enable bit is ignored).

- 1: Watchdog timer permanently set
- 0: Watchdog timer not permanently set

WDT Enable (Bit 1)

The WDT Enable bit enables or disables the Watchdog timer.

- 1: Enable Watchdog timer operation
- 0: Disable Watchdog timer operation

Reset Strobe (Bit 0)

The Reset Strobe is a write-only bit that resets the Watchdog timer count. It must be set to '1' before the count expires to avoid a Watchdog trigger

- 1: Reset Count

Reserved

All reserved bits must be written as '0'.

Timer n Register [R/W]

- Timer 0 Register 0xC010
- Timer 1 Register 0xC012

Figure 16. Timer n Register

Bit #	15	14	13	12	11	10	9	8
Field	Count...							
Read/Write	R/W	R/W	R/W	R/W	R/W	R/W	R/W	R/W
Default	1	1	1	1	1	1	1	1

Bit #	7	6	5	4	3	2	1	0
Field	...Count							
Read/Write	R/W	R/W	R/W	R/W	R/W	R/W	R/W	R/W
Default	1	1	1	1	1	1	1	1

Register Description

The Timer n Register sets the Timer n count. Both Timer 0 and Timer 1 decrement by one every 1-μs clock tick. Each can provide an interrupt to the CPU when the timer reaches zero.

Count (Bits [15:0])

The Count field sets the Timer count.

General USB Registers

There is one set of registers dedicated to general USB control. This set consists of two identical registers, one for Host/Device Port 1 and one for Host/Device Port 2. This register set has functions for both USB host and USB peripheral options and is covered in this section and summarized in Table 22. USB Host-only registers are covered in Section “USB Host Only Registers” on page 22 and USB Device-only registers are covered in Section “USB Device Only Registers” on page 30.

Table 22. USB Registers [8]

Register Name	Address (SIE1/SIE2)	R/W
USB n Control Register	0xC08A/0xC0AA	R/W

USB n Control Register [R/W]

- USB 1 Control Register 0xC08A
- USB 2 Control Register 0xC0AA

Figure 17. USB n Control Register

Bit #	15	14	13	12	11	10	9	8
Field	Reserved		Port A D+ Status	Port A D- Status	Reserved	LOA	Mode Select	Reserved
Read/Write	-	-	R	R	-	R/W	R/W	-
Default	X	X	X	X	0	0	0	0

Bit #	7	6	5	4	3	2	1	0
Field	Port A Resistors Enable	Reserved		Port A Force D± State		Suspend Enable	Reserved	Port A SOF/EOP Enable
Read/Write	R/W	-	-	R/W	R/W	R/W	-	R/W
Default	0	0	0	0	0	0	0	0

Note

8. Errata: Writing to the SIE2 Control register via HPI can corrupt the SIE1 control register. Writing to the SIE1 Control register via HPI can corrupt the SIE2 control register. For more information, see the Errata on page 84.

Register Description

The USB n Control register is used in both host and device mode. It monitors and controls the SIE and the data lines of the USB ports. This register can be accessed by the HPI interface.

Port A D+ Status (Bit 13)

The Port A D+ Status bit is a read-only bit that indicates the value of DATA+ on Port A.

1: D+ is high

0: D+ is low

Port A D– Status (Bit 12)

The Port A D– Status bit is a read-only bit that indicates the value of DATA– on Port A.

1: D– is high

0: D– is low

LOA (Bit 10)

The LOA bit selects the speed of Port A.

1: Port A is set to Low-speed mode

0: Port A is set to Full-speed mode

Mode Select (Bit 9)

The Mode Select bit sets the SIE for host or device operation. When set for device operation only one USB port is supported. The active port is selected by the Port Select bit in the Host n Count Register.

1: Host mode

0: Device mode

Port A Resistors Enable (Bit 7)

The Port A Resistors Enable bit enables or disables the pull-up/pull-down resistors on Port A. When enabled, the Mode Select bit and LOA bit of this register sets the pull-up/pull-down resistors appropriately. When the Mode Select is set for Host mode, the pull-down resistors on the data lines (D+ and D–) are enabled. When the Mode Select is set for Device mode, a single pull-up resistor on either D+ or D–, determined by the LOA bit, will be enabled. See [Table 23](#) for details.

1: Enable pull-up/pull-down resistors

0: Disable pull-up/pull-down resistors

Table 23. USB Data Line Pull-up and Pull-down Resistors

LOA	Mode Select	Port n Resistors Enable	Function
X	X	0	Pull up/Pull down on D+ and D– Disabled
X	1	1	Pull down on D+ and D– Enabled
1	0	1	Pull up on USB D– Enabled
0	0	1	Pull up on USB D+ Enabled

Port A Force D± State (Bits [4:3])

The Port A Force D± State field controls the forcing state of the D+ D– data lines for Port A. This field forces the state of the Port A data lines independent of the Port Select bit setting. See [Table 24](#) for details.

Table 24. Port A Force D± State

Port A Force D± State		Function
MSB	LSB	
0	0	Normal Operation
0	1	Force USB Reset, SE0 State
1	0	Force J-State
1	1	Force K-State

Suspend Enable (Bit 2)

The Suspend Enable bit enables or disables the suspend feature on both ports. When suspend is enabled the USB transceivers are powered down and can not transmit or received USB packets but can still monitor for a wakeup condition.

1: Enable suspend

0: Disable suspend

Port A SOF/EOP Enable (Bit 0)

The Port A SOF/EOP Enable bit is only applicable in host mode. In Device mode this bit must be written as '0'. In host mode this bit enables or disables SOFs or EOPs for Port A. Either SOFs or EOPs will be generated depending on the LOA bit in the USB n Control Register when Port A is active.

1: Enable SOFs or EOPs

0: Disable SOFs or EOPs

Reserved

All reserved bits must be written as '0'.

USB Host Only Registers

There are twelve sets of dedicated registers to USB host only operation. Each set consists of two identical registers (unless otherwise noted); one for Host Port 1 and one for Host Port 2. These register sets are covered in this section and summarized in Table 25.

Table 25. USB Host Only Register

Register Name	Address (Host 1/Host 2)	R/W
Host n Control Register	0xC080/0xC0A0	R/W
Host n Address Register	0xC082/0xC0A2	R/W
Host n Count Register	0xC084/0xC0A4	R/W
Host n Endpoint Status Register	0xC086/0xC0A6	R
Host n PID Register	0xC086/0xC0A6	W
Host n Count Result Register	0xC088/0xC0A8	R
Host n Device Address Register	0xC088/0xC0A8	W
Host n Interrupt Enable Register	0xC08C/0xC0AC	R/W
Host n Status Register	0xC090/0xC0B0	R/W
Host n SOF/EOP Count Register	0xC092/0xC0B2	R/W
Host n SOF/EOP Counter Register	0xC094/0xC0B4	R
Host n Frame Register	0xC096/0xC0B6	R

Host n Control Register [R/W]

- Host 1 Control Register 0xC080
- Host 2 Control Register 0xC0A0

Figure 18. Host n Control Register

Bit #	15	14	13	12	11	10	9	8
Field	Reserved							
Read/Write	-	-	-	-	-	-	-	-
Default	0	0	0	0	0	0	0	0

Bit #	7	6	5	4	3	2	1	0
Field	Preamble Enable	Sequence Select	Sync Enable	ISO Enable	Reserved			Arm Enable
Read/Write	R/W	R/W	R/W	R/W	-	-	-	R/W
Default	0	0	0	0	0	0	0	0

Register Description

The Host n Control register allows high-level USB transaction control.

Preamble Enable (Bit 7)

The Preamble Enable bit enables or disables the transmission of a preamble packet before all low-speed packets. This bit should only be set when communicating with a low-speed device.

1: Enable Preamble packet

0: Disable Preamble packet

Sequence Select (Bit 6)

The Sequence Select bit sets the data toggle for the next packet. This bit has no effect on receiving data packets; sequence checking must be handled in firmware.

1: Send DATA1

0: Send DATA0

Sync Enable (Bit 5)

The Sync Enable bit synchronizes the transfer with the SOF packet in full-speed mode and the EOP packet in low-speed mode.

Host n Address Register [R/W]

■ Host 1 Address Register 0xC082

■ Host 2 Address Register 0xC0A2

Figure 19. Host n Address Register

Bit #	15	14	13	12	11	10	9	8
Field	Address...							
Read/Write	R/W	R/W	R/W	R/W	R/W	R/W	R/W	R/W
Default	0	0	0	0	0	0	0	0

Bit #	7	6	5	4	3	2	1	0
Field	...Address							
Read/Write	R/W	R/W	R/W	R/W	R/W	R/W	R/W	R/W
Default	0	0	0	0	0	0	0	0

Register Description

The Host n Address register is used as the base pointer into memory space for the current host transactions.

1: The next enabled packet will be transferred after the SOF or EOP packet is transmitted

0: The next enabled packet will be transferred as soon as the SIE is free

ISO Enable (Bit 4)

The ISO Enable bit enables or disables an Isochronous transaction.

1: Enable Isochronous transaction

0: Disable Isochronous transaction

Arm Enable (Bit 0)

The Arm Enable bit arms an endpoint and starts a transaction. This bit is automatically cleared to '0' when a transaction is complete.

1: Arm endpoint and begin transaction

0: Endpoint disarmed

Reserved

All reserved bits must be written as '0'.

Address (Bits [15:0])

The Address field sets the address pointer into internal RAM or ROM.

Host n Count Register [R/W]

- Host 1 Count Register 0xC084
- Host 2 Count Register 0xC0A4

Figure 20. Host n Count Register

Bit #	15	14	13	12	11	10	9	8
Field	Reserved						Count...	
Read/Write	-	-	-	-	-	-	R/W	R/W
Default	0	0	0	0	0	0	0	0

Bit #	7	6	5	4	3	2	1	0
Field	...Count							
Read/Write	R/W	R/W	R/W	R/W	R/W	R/W	R/W	R/W
Default	0	0	0	0	0	0	0	0

Register Description

The Host n Count register is used to hold the number of bytes (packet length) for the current transaction. The maximum packet length is 1023 bytes in ISO mode. The Host Count value is used to determine how many bytes to transmit, or the maximum number of bytes to receive. If the number of received bytes is greater than the Host Count value then an overflow condition will be flagged by the Overflow bit in the Host n Endpoint Status register.

Count (Bits [9:0])

The Count field sets the value for the current transaction data packet length. This value is retained when switching between host and device mode, and back again.

Reserved

All reserved bits must be written as '0'.

Host n Endpoint Status Register [R]

- Host 1 Endpoint Status Register 0xC086
- Host 2 Endpoint Status Register 0xC0A6

Figure 21. Host n Endpoint Status Register

Bit #	15	14	13	12	11	10	9	8
Field	Reserved				Overflow Flag	Underflow Flag	Reserved	
Read/Write	-	-	-	-	R	R	-	-
Default	0	0	0	0	0	0	0	0

Bit #	7	6	5	4	3	2	1	0
Field	Stall Flag	NAK Flag	Length Exception Flag	Reserved	Sequence Status	Timeout Flag	Error Flag	ACK Flag
Read/Write	R	R	R	-	R	R	R	R
Default	0	0	0	0	0	0	0	0

Register Description

The Host n Endpoint Status register is a read-only register that provides status for the last USB transaction.

Overflow Flag (Bit 11)

The Overflow Flag bit indicates that the received data in the last data transaction exceeded the maximum length specified in the Host n Count Register. The Overflow Flag should be checked in response to a Length Exception signified by the Length Exception Flag set to '1'.

1: Overflow condition occurred

0: Overflow condition did not occur

Underflow Flag (Bit 10)

The Underflow Flag bit indicates that the received data in the last data transaction was less than the maximum length specified in the Host n Count register. The Underflow Flag should be checked in response to a Length Exception signified by the Length Exception Flag set to '1'.

1: Underflow condition occurred

0: Underflow condition did not occur

Stall Flag (Bit 7)

The Stall Flag bit indicates that the peripheral device replied with a Stall in the last transaction.

- 1: Device returned Stall
- 0: Device did not return Stall

NAK Flag (Bit 6)

The NAK Flag bit indicates that the peripheral device replied with a NAK in the last transaction.

- 1: Device returned NAK
- 0: Device did not return NAK

Length Exception Flag (Bit 5)

The Length Exception Flag bit indicates the received data in the data stage of the last transaction does not equal the maximum Host Count specified in the Host n Count register. A Length Exception can either mean an overflow or underflow and the Overflow and Underflow flags (bits 11 and 10, respectively) should be checked to determine which event occurred.

- 1: An overflow or underflow condition occurred
- 0: An overflow or underflow condition did not occur

Sequence Status (Bit 3)

The Sequence Status bit indicates the state of the last received data toggle from the device. Firmware is responsible for monitoring and handling the sequence status. The Sequence bit is only valid if the ACK bit is set to '1'. The Sequence bit is set to '0' when an error is detected in the transaction and the Error bit will be set.

- 1: DATA1
- 0: DATA0

Host n PID Register [W]

- Host 1 PID Register 0xC086
- Host 2 PID Register 0xC0A6

Figure 22. Host n PID Register

Bit #	15	14	13	12	11	10	9	8
Field	Reserved							
Read/Write	-	-	-	-	-	-	-	-
Default	0	0	0	0	0	0	0	0

Bit #	7	6	5	4	3	2	1	0
Field	PID Select				Endpoint Select			
Read/Write	W	W	W	W	W	W	W	W
Default	0	0	0	0	0	0	0	0

Timeout Flag (Bit 2)

The Timeout Flag bit indicates if a timeout condition occurred for the last transaction. A timeout condition can occur when a device either takes too long to respond to a USB host request or takes too long to respond with a handshake.

- 1: Timeout occurred
- 0: Timeout did not occur

Error Flag (Bit 1)

The Error Flag bit indicates a transaction failed for any reason other than the following: Timeout, receiving a NAK, or receiving a STALL. Overflow and Underflow are not considered errors and do not affect this bit. CRC5 and CRC16 errors will result in an Error flag along with receiving incorrect packet types.

- 1: Error detected
- 0: No error detected

ACK Flag (Bit 0)

The ACK Flag bit indicates two different conditions depending on the transfer type. For non-Isochronous transfers, this bit represents a transaction ending by receiving or sending an ACK packet. For Isochronous transfers, this bit represents a successful transaction that will not be represented by an ACK packet.

- 1: For non-Isochronous transfers, the transaction was ACKed. For Isochronous transfers, the transaction was completed successfully.
- 0: For non-Isochronous transfers, the transaction was not ACKed. For Isochronous transfers, the transaction was not completed successfully.

Register Description

The Host n PID register is a write-only register that provides the PID and Endpoint information to the USB SIE to be used in the next transaction.

PID Select (Bits [7:4])

The PID Select field defined as in Table 26. ACK and NAK tokens are automatically sent based on settings in the Host n Control register and do not need to be written in this register.

Table 26. PID Select Definition

PID TYPE	PID Select [7:4]
set-up	1101 (D Hex)
IN	1001 (9 Hex)
OUT	0001 (1 Hex)
SOF	0101 (5 Hex)

Host n Count Result Register [R]

- Host 1 Count Result Register 0xC088
- Host 2 Count Result Register 0xC0A8

Figure 23. Host n Count Result Register

Bit #	15	14	13	12	11	10	9	8
Field	Result...							
Read/Write	R	R	R	R	R	R	R	R
Default	0	0	0	0	0	0	0	0

Bit #	7	6	5	4	3	2	1	0
Field	...Result							
Read/Write	R	R	R	R	R	R	R	R
Default	0	0	0	0	0	0	0	0

Register Description

The Host n Count Result register is a read-only register that contains the size difference in bytes between the Host Count Value specified in the Host n Count register and the last packet received. If an overflow or underflow condition occurs, that is the received packet length differs from the value specified in the Host n Count register, the Length Exception Flag bit in the Host n Endpoint Status register will be set. The value in this register is only valid when the Length Exception Flag bit is set and the Error Flag bit is not set; both bits are in the Host n Endpoint Status register.

Table 26. PID Select Definition (continued)

PID TYPE	PID Select [7:4]
PREAMBLE	1100 (C Hex)
NAK	1010 (A Hex)
STALL	1110 (E Hex)
DATA0	0011 (3 Hex)
DATA1	1011 (B Hex)

Endpoint Select (Bits [3:0])

The Endpoint field allows addressing of up to 16 different endpoints.

Reserved

All reserved bits must be written as '0'.

Result (Bits [15:0])

The Result field contains the differences in bytes between the received packet and the value specified in the Host n Count register. If an overflow condition occurs, Result [15:10] is set to '111111', a 2's complement value indicating the additional byte count of the received packet. If an underflow condition occurs, Result [15:0] indicates the excess byte count (number of bytes not used).

Reserved

All reserved bits must be written as '0'.

Host n Device Address Register [W]

- Host 1 Device Address Register 0xC088
- Host 2 Device Address Register 0xC0A8

Figure 24. Host n Device Address Register

Bit #	15	14	13	12	11	10	9	8
Field	Reserved...							
Read/Write	-	-	-	-	-	-	-	-
Default	0	0	0	0	0	0	0	0

Bit #	7	6	5	4	3	2	1	0
Field	...Reserved	Address						
Read/Write	-	W	W	W	W	W	W	W
Default	0	0	0	0	0	0	0	0

Register Description

The Host n Device Address register is a write-only register that contains the USB Device Address that the host wishes to communicate with.

Address (Bits [6:0])

The Address field contains the value of the USB address for the next device that the host is going to communicate with. This value must be written by firmware.

Reserved

All reserved bits must be written as '0'.

Host n Interrupt Enable Register [R/W]

- Host 1 Interrupt Enable Register 0xC08C
- Host 2 Interrupt Enable Register 0xC0AC

Figure 25. Host n Interrupt Enable Register

Bit #	15	14	13	12	11	10	9	8
Field	VBUS Interrupt Enable	ID Interrupt Enable	Reserved				SOF/EOP Interrupt Enable	Reserved
Read/Write	R/W	R/W	-	-	-	-	R/W	-
Default	0	0	0	0	0	0	0	0

Bit #	7	6	5	4	3	2	1	0
Field	Reserved	Port A Wake Interrupt Enable	Reserved	Port A Connect Change Interrupt Enable	Reserved			Done Interrupt Enable
Read/Write	-	R/W	-	R/W	-	-	-	R/W
Default	0	0	0	0	0	0	0	0

Register Description

The Host n Interrupt Enable register allows control over host-related interrupts.

In this register a bit set to '1' enables the corresponding interrupt while '0' disables the interrupt.

VBUS Interrupt Enable (Bit 15)

The VBUS Interrupt Enable bit enables or disables the OTG VBUS interrupt. When enabled this interrupt triggers on both the rising and falling edge of VBUS at the 4.4 V status (only supported in Port 1A). This bit is only available for Host 1 and is a reserved bit in Host 2.

1: Enable VBUS interrupt

0: Disable VBUS interrupt

ID Interrupt Enable (Bit 14)

The ID Interrupt Enable bit enables or disables the OTG ID interrupt. When enabled this interrupt triggers on both the rising and falling edge of the OTG ID pin (only supported in Port 1A). This bit is only available for Host 1 and is a reserved bit in Host 2.

1: Enable ID interrupt

0: Disable ID interrupt

SOF/EOP Interrupt Enable (Bit 9)

The SOF/EOP Interrupt Enable bit enables or disables the SOF/EOP timer interrupt.

- 1: Enable SOF/EOP timer interrupt
- 0: Disable SOF/EOP timer interrupt

Port A Wake Interrupt Enable (Bit 6)

The Port A Wake Interrupt Enable bit enables or disables the remote wakeup interrupt for Port A.

- 1: Enable remote wakeup interrupt for Port A
- 0: Disable remote wakeup interrupt for Port A

Port A Connect Change Interrupt Enable (Bit 4)

The Port A Connect Change Interrupt Enable bit enables or disables the Connect Change interrupt on Port A. This interrupt triggers when either a device is inserted (SE0 state to J state) or a device is removed (J state to SE0 state).

Host n Status Register [R/W]

- Host 1 Status Register 0xC090
- Host 2 Status Register 0xC0B0

Figure 26. Host n Status Register

Bit #	15	14	13	12	11	10	9	8
Field	VBUS Interrupt Flag	ID Interrupt Flag	Reserved				SOF/EOP Interrupt Flag	Reserved
Read/Write	R/W	R/W	-	-	-	-	R/W	-
Default	X	X	X	X	X	X	X	X

Bit #	7	6	5	4	3	2	1	0
Field	Reserved	Port A Wake Interrupt Flag	Reserved	Port A Connect Change Interrupt Flag	Reserved	Port A SE0 Status	Reserved	Done Interrupt Flag
Read/Write	-	R/W	-	R/W	-	R/W	-	R/W
Default	X	X	X	X	X	X	X	X

Register Description

The Host n Status register provides status information for host operation. Pending interrupts can be cleared by writing a '1' to the corresponding bit. This register can be accessed by the HPI interface.

VBUS Interrupt Flag (Bit 15)

The VBUS Interrupt Flag bit indicates the status of the OTG VBUS interrupt (only for Port 1A). When enabled this interrupt triggers on both the rising and falling edge of VBUS at 4.4 V. This bit is only available for Host 1 and is a reserved bit in Host 2.

- 1: Interrupt triggered
- 0: Interrupt did not trigger

ID Interrupt Flag (Bit 14)

- 1: Enable Connect Change interrupt
- 0: Disable Connect Change interrupt

Done Interrupt Enable (Bit 0)

The Done Interrupt Enable bit enables or disables the USB Transfer Done interrupt. The USB Transfer Done triggers when either the host responds with an ACK, or a device responds with any of the following: ACK, NAK, STALL, or Timeout. This interrupt is used for both Port A and Port B.

- 1: Enable USB Transfer Done interrupt
- 0: Disable USB Transfer Done interrupt

Reserved

All reserved bits must be written as '0'.

The ID Interrupt Flag bit indicates the status of the OTG ID interrupt (only for Port 1A). When enabled this interrupt triggers on both the rising and falling edge of the OTG ID pin. This bit is only available for Host 1 and is a reserved bit in Host 2.

- 1: Interrupt triggered
- 0: Interrupt did not trigger

SOF/EOP Interrupt Flag (Bit 9)

The SOF/EOP Interrupt Flag bit indicates the status of the SOF/EOP Timer interrupt. This bit triggers '1' when the SOF/EOP timer expires.

- 1: Interrupt triggered
- 0: Interrupt did not trigger

Port A Wake Interrupt Flag (Bit 6)

The Port A Wake Interrupt Flag bit indicates remote wakeup on Port A.

1: Interrupt triggered

0: Interrupt did not trigger

Port A Connect Change Interrupt Flag (Bit 4)

The Port A Connect Change Interrupt Flag bit indicates the status of the Connect Change interrupt on Port A. This bit triggers '1' on either a rising edge or falling edge of a USB Reset condition (device inserted or removed). Together with the Port A SE0 Status bit, it can be determined whether a device was inserted or removed.

1: Interrupt triggered

0: Interrupt did not trigger

Port A SE0 Status (Bit 2)

The Port A SE0 Status bit indicates if Port A is in an SE0 state or not. Together with the Port A Connect change Interrupt Flag bit, it can be determined whether a device was inserted (non-SE0 condition) or removed (SE0 condition).

1: SE0 condition

0: Non-SE0 condition

Done Interrupt Flag (Bit 0)

The Done Interrupt Flag bit indicates the status of the USB Transfer Done interrupt. The USB Transfer Done triggers when either the host responds with an ACK, or a device responds with any of the following: ACK, NAK, STALL, or Timeout. This interrupt is used for both Port A and Port B.

1: Interrupt triggered

0: Interrupt did not trigger

Host n SOF/EOP Count Register [R/W]

■ Host 1 SOF/EOP Count Register 0xC092

■ Host 2 SOF/EOP Count Register 0xC0B2

Figure 27. Host n SOF/EOP Count Register

Bit #	15	14	13	12	11	10	9	8
Field	Reserved		Count...					
Read/Write	-	-	R/W	R/W	R/W	R/W	R/W	R/W
Default	0	0	1	0	1	1	1	0

Bit #	7	6	5	4	3	2	1	0
Field	...Count							
Read/Write	R/W	R/W	R/W	R/W	R/W	R/W	R/W	R/W
Default	1	1	1	0	0	0	0	0

Register Description

The Host n SOF/EOP Count register contains the SOF/EOP Count Value that is loaded into the SOF/EOP counter. This value is loaded each time the SOF/EOP counter counts down to zero. The default value set in this register at power-up is 0x2EE0, which will generate a 1-ms time frame. The SOF/EOP counter is a down counter decremented at a 12-MHz rate. When this register is read, the value returned is the programmed SOF/EOP count value.

Count (Bits [13:0])

The Count field sets the SOF/EOP counter duration.

Reserved

All reserved bits must be written as '0'.

Host n SOF/EOP Counter Register [R]

- Host 1 SOF/EOP Counter Register 0xC094
- Host 2 SOF/EOP Counter Register 0xC0B4

Figure 28. Host n SOF/EOP Counter Register

Bit #	15	14	13	12	11	10	9	8
Field	Reserved			Counter...				
Read/Write	-	-	R	R	R	R	R	R
Default	X	X	X	X	X	X	X	X

Bit #	7	6	5	4	3	2	1	0
Field	...Counter							
Read/Write	R	R	R	R	R	R	R	R
Default	X	X	X	X	X	X	X	X

Register Description

The Host n SOF/EOP Counter register contains the current value of the SOF/EOP down counter. This value can be used to determine the time remaining in the current frame.

Counter (Bits [13:0])

The Counter field contains the current value of the SOF/EOP down counter.

Host n Frame Register [R]

- Host 1 Frame Register 0xC096
- Host 2 Frame Register 0xC0B6

Figure 29. Host n Frame Register

Bit #	15	14	13	12	11	10	9	8
Field	Reserved					Frame...		
Read/Write	-	-	-	-	-	R	R	R
Default	0	0	0	0	0	0	0	0

Bit #	7	6	5	4	3	2	1	0
Field	...Frame							
Read/Write	R	R	R	R	R	R	R	R
Default	0	0	0	0	0	0	0	0

Register Description

The Host n Frame register maintains the next frame number to be transmitted (current frame number + 1). This value is updated after each SOF transmission. This register resets to 0x0000 after each CPU write to the Host n SOF/EOP Count register (Host 1: 0xC092, Host 2: 0xC0B2).

Reserved

All reserved bits must be written as '0'.

Frame (Bits [10:0])

The Frame field contains the next frame number to be transmitted.

USB Device Only Registers

There are ten sets of USB Device Only registers. All sets consist of at least two registers, one for Device Port 1 and one for Device Port 2. In addition, each Device port has eight possible endpoints. This gives each endpoint register set eight registers for each Device Port for a total of 16 registers per set. The USB Device Only registers are covered in this section and summarized in Table 27.

Table 27. USB Device Only Registers

Register Name	Address (Device 1/Device 2)	R/W
Device n Endpoint n Control Register	0x02n0	R/W
Device n Endpoint n Address Register	0x02n2	R/W

Table 27. USB Device Only Registers (continued)

Register Name	Address (Device 1/Device 2)	R/W
Device n Endpoint n Count Register	0x02n4	R/W
Device n Endpoint n Status Register	0x02n6	R/W
Device n Endpoint n Count Result Register	0x02n8	R/W
Device n Interrupt Enable Register	0xC08C/0xC0AC	R/W
Device n Address Register	0xC08E/0xC0AE	R/W
Device n Status Register	0xC090/0xCB0	R/W
Device n Frame Number Register	0xC092/0xC0B2	R
Device n SOF/EOP Count Register	0xC094/0xC0B4	W

Device n Endpoint n Control Register [R/W]

- Device n Endpoint 0 Control Register [Device 1: 0x0200 Device 2: 0x0280]
- Device n Endpoint 1 Control Register [Device 1: 0x0210 Device 2: 0x0290]
- Device n Endpoint 2 Control Register [Device 1: 0x0220 Device 2: 0x02A0]
- Device n Endpoint 3 Control Register [Device 1: 0x0230 Device 2: 0x02B0]
- Device n Endpoint 4 Control Register [Device 1: 0x0240 Device 2: 0x02C0]
- Device n Endpoint 5 Control Register [Device 1: 0x0250 Device 2: 0x02D0]
- Device n Endpoint 6 Control Register [Device 1: 0x0260 Device 2: 0x02E0]
- Device n Endpoint 7 Control Register [Device 1: 0x0270 Device 2: 0x02F0]

Figure 30. Device n Endpoint n Control Register

Bit #	15	14	13	12	11	10	9	8
Field	Reserved							
Read/Write	-	-	-	-	-	-	-	-
Default	X	X	X	X	X	X	X	X

Bit #	7	6	5	4	3	2	1	0
Field	IN/OUT Ignore Enable	Sequence Select	Stall Enable	ISO Enable	NAK Interrupt Enable	Direction Select	Enable	Arm Enable
Read/Write	R/W	R/W	R/W	R/W	R/W	R/W	R/W	R/W
Default	X	X	X	X	X	X	X	X

Register Description

The Device n Endpoint n Control register provides control over a single EP in device mode. There are a total of eight endpoints for each of the two ports. All endpoints have the same definition for their Device n Endpoint n Control register.

IN/OUT Ignore Enable (Bit 6)

The IN/OUT Ignore Enable bit forces endpoint 0 (EP0) to ignore all IN and OUT requests. This bit must be set so that EP0 only accepts Setup packets at the start of each transfer. This bit must be cleared to accept IN/OUT transactions. This bit only applies to EP0.

- 1: Ignore IN/OUT requests
- 0: Do not ignore IN/OUT requests

Sequence Select (Bit 6)

The Sequence Select bit determines whether a DATA0 or a DATA1 will be sent for the next data toggle. This bit has no effect on receiving data packets, sequence checking must be handled in firmware.

- 1: Send a DATA1
- 0: Send a DATA0

Stall Enable (Bit 5)

The Stall Enable bit sends a Stall in response to the next request (unless it is a setup request, which are always ACKed). This is a sticky bit and continues to respond with Stalls until cleared by firmware.

- 1: Send Stall

0: Do not send Stall

ISO Enable (Bit 4)

The ISO Enable bit enables and disables an Isochronous transaction. This bit is only valid for EPs 1–7 and has no function for EP0.

1: Enable Isochronous transaction

0: Disable Isochronous transaction

NAK Interrupt Enable (Bit 3)

The NAK Interrupt Enable bit enables and disables the generation of an Endpoint n interrupt when the device responds to the host with a NAK. The Endpoint n Interrupt Enable bit in the Device n Interrupt Enable register must also be set. When a NAK is sent to the host, the corresponding EP Interrupt Flag in the Device n Status register will be set. In addition, the NAK Flag in the Device n Endpoint n Status register will be set.

1: Enable NAK interrupt

0: Disable NAK interrupt

Direction Select (Bit 2)

The Direction Select bit needs to be set according to the expected direction of the next data stage in the next transaction. If the data stage direction is different from what is set in this bit, it will get NAKed and either the IN Exception Flag or the OUT Exception Flag will be set in the Device n Endpoint n Status register. If a setup packet is received and the Direction Select bit

is set incorrectly, the setup will be ACKed and the Set-up Status Flag will be set (refer to the setup bit of the Device n Endpoint n Status register for details).

1: OUT transfer (host to device)

0: IN transfer (device to host)

Enable (Bit 1)

The Enable bit must be set to allow transfers to the endpoint. If Enable is set to '0' then all USB traffic to this endpoint is ignored. If Enable is set '1' and Arm Enable (bit 0) is set '0' then NAKs will automatically be returned from this endpoint (except setup packets, which are always ACKed as long as the Enable bit is set).

1: Enable transfers to an endpoint

0: Do not allow transfers to an endpoint

Arm Enable (Bit 0)

The Arm Enable bit arms the endpoint to transfer or receive a packet. This bit is cleared to '0' when a transaction is complete.

1: Arm endpoint

0: Endpoint disarmed

Reserved

All reserved bits must be written as '0'.

Device n Endpoint n Address Register [R/W]

- Device n Endpoint 0 Address Register [Device 1: 0x0202 Device 2: 0x0282]
- Device n Endpoint 1 Address Register [Device 1: 0x0212 Device 2: 0x0292]
- Device n Endpoint 2 Address Register [Device 1: 0x0222 Device 2: 0x02A2]
- Device n Endpoint 3 Address Register [Device 1: 0x0232 Device 2: 0x02B2]
- Device n Endpoint 4 Address Register [Device 1: 0x0242 Device 2: 0x02C2]
- Device n Endpoint 5 Address Register [Device 1: 0x0252 Device 2: 0x02D2]
- Device n Endpoint 6 Address Register [Device 1: 0x0262 Device 2: 0x02E2]
- Device n Endpoint 7 Address Register [Device 1: 0x0272 Device 2: 0x02F2]

Figure 31. Device n Endpoint n Address Register

Bit #	15	14	13	12	11	10	9	8
Field	Address...							
Read/Write	R/W	R/W	R/W	R/W	R/W	R/W	R/W	R/W
Default	X	X	X	X	X	X	X	X

Bit #	7	6	5	4	3	2	1	0
Field	...Address							
Read/Write	R/W	R/W	R/W	R/W	R/W	R/W	R/W	R/W
Default	X	X	X	X	X	X	X	X

Register Description

The Device n Endpoint n Address register is used as the base pointer into memory space for the current Endpoint transaction. There are a total of eight endpoints for each of the two ports. All endpoints have the same definition for their Device n Endpoint n Address register.

Address (Bits [15:0])

The Address field sets the base address for the current transaction on a signal endpoint.

Device n Endpoint n Count Register [R/W]

- Device n Endpoint 0 Count Register [Device 1: 0x0204 Device 2: 0x0284]
- Device n Endpoint 1 Count Register [Device 1: 0x0214 Device 2: 0x0294]
- Device n Endpoint 2 Count Register [Device 1: 0x0224 Device 2: 0x02A4]
- Device n Endpoint 3 Count Register [Device 1: 0x0234 Device 2: 0x02B4]
- Device n Endpoint 4 Count Register [Device 1: 0x0244 Device 2: 0x02C4]
- Device n Endpoint 5 Count Register [Device 1: 0x0254 Device 2: 0x02D4]
- Device n Endpoint 6 Count Register [Device 1: 0x0264 Device 2: 0x02E4]
- Device n Endpoint 7 Count Register [Device 1: 0x0274 Device 2: 0x02F4]

Figure 32. Device n Endpoint n Count Register

Bit #	15	14	13	12	11	10	9	8
Field	Reserved						Count...	
Read/Write	-	-	-	-	-	-	R/W	R/W
Default	X	X	X	X	X	X	X	X

Bit #	7	6	5	4	3	2	1	0
Field	...Count							
Read/Write	R/W	R/W	R/W	R/W	R/W	R/W	R/W	R/W
Default	X	X	X	X	X	X	X	X

Register Description

The Device n Endpoint n Count register designates the maximum packet size that can be received from the host for OUT transfers for a single endpoint. This register also designates the packet size to be sent to the host in response to the next IN token for a single endpoint. The maximum packet length is 1023 bytes in ISO mode. There are a total of eight endpoints for each of the two ports. All endpoints have the same definition for their Device n Endpoint n Count register.

Count (Bits [9:0])

The Count field sets the current transaction packet length for a single endpoint.

Reserved

All reserved bits must be written as '0'.

Device n Endpoint n Status Register [R/W]

- Device n Endpoint 0 Status Register [Device 1: 0x0206 Device 2: 0x0286]
- Device n Endpoint 1 Status Register [Device 1: 0x0216 Device 2: 0x0296]
- Device n Endpoint 2 Status Register [Device 1: 0x0226 Device 2: 0x02A6]
- Device n Endpoint 3 Status Register [Device 1: 0x0236 Device 2: 0x02B6]
- Device n Endpoint 4 Status Register [Device 1: 0x0246 Device 2: 0x02C6]
- Device n Endpoint 5 Status Register [Device 1: 0x0256 Device 2: 0x02D6]
- Device n Endpoint 6 Status Register [Device 1: 0x0266 Device 2: 0x02E6]
- Device n Endpoint 7 Status Register [Device 1: 0x0276 Device 2: 0x02F6]

Figure 33. Device n Endpoint n Status Register

Bit #	15	14	13	12	11	10	9	8
Field	Reserved				Overflow Flag	Underflow Flag	OUT Exception Flag	IN Exception Flag
Read/Write	-	-	-	-	R/W	R/W	R/W	R/W
Default	X	X	X	X	X	X	X	X

Bit #	7	6	5	4	3	2	1	0
Field	Stall Flag	NAK Flag	Length Exception Flag	Setup Flag	Sequence Flag	Timeout Flag	Error Flag	ACK Flag
Read/Write	R/W	R/W	R/W	R/W	R/W	R/W	R/W	R/W
Default	X	X	X	X	X	X	X	X

Register Description

The Device n Endpoint n Status register provides packet status information for the last transaction received or transmitted. This register is updated in hardware and does not need to be cleared by firmware. There are a total of eight endpoints for each of the two ports. All endpoints have the same definition for their Device n Endpoint n Status register.

The Device n Endpoint n Status register is a memory-based register that must be initialized to 0x0000 before USB Device operations are initiated. After initialization, this register must not be written to again.

Overflow Flag (Bit 11)

The Overflow Flag bit indicates that the received data in the last data transaction exceeded the maximum length specified in the Device n Endpoint n Count register. The Overflow Flag should be checked in response to a Length Exception signified by the Length Exception Flag set to '1'.

1: Overflow condition occurred

0: Overflow condition did not occur

Underflow Flag (Bit 10)

The Underflow Flag bit indicates that the received data in the last data transaction was less than the maximum length specified in the Device n Endpoint n Count register. The Underflow Flag should be checked in response to a Length Exception signified by the Length Exception Flag set to '1'.

1: Underflow condition occurred

0: Underflow condition did not occur

OUT Exception Flag (Bit 9)

The OUT Exception Flag bit indicates when the device received an OUT packet when armed for an IN.

1: Received OUT when armed for IN

0: Received IN when armed for IN

IN Exception Flag (Bit 8)

The IN Exception Flag bit indicates when the device received an IN packet when armed for an OUT.

1: Received IN when armed for OUT

0: Received OUT when armed for OUT

Stall Flag (Bit 7)

The Stall Flag bit indicates that a Stall packet was sent to the host.

1: Stall packet was sent to the host

0: Stall packet was not sent

NAK Flag (Bit 6)

The NAK Flag bit indicates that a NAK packet was sent to the host.

1: NAK packet was sent to the host

0: NAK packet was not sent

Length Exception Flag (Bit 5)

The Length Exception Flag bit indicates the received data in the data stage of the last transaction does not equal the maximum Endpoint Count specified in the Device n Endpoint n Count register. A Length Exception can either mean an overflow or underflow and the Overflow and Underflow flags (bits 11 and 10, respectively) should be checked to determine which event occurred.

1: An overflow or underflow condition occurred

0: An overflow or underflow condition did not occur

Setup Flag (Bit 4)

The Setup Flag bit indicates that a setup packet was received. In device mode setup packets are stored at memory location 0x0300 for Device 1 and 0x0308 for Device 2. Setup packets are always accepted regardless of the Direction Select and Arm

Enable bit settings as long as the Device n EP n Control register Enable bit is set.

1: Setup packet was received

0: Setup packet was not received

Sequence Flag (Bit 3)

The Sequence Flag bit indicates whether the last data toggle received was a DATA1 or a DATA0. This bit has no effect on receiving data packets; sequence checking must be handled in firmware.

1: DATA1 was received

0: DATA0 was received

Timeout Flag (Bit 2)

The Timeout Flag bit indicates whether a timeout condition occurred on the last transaction. On the device side, a timeout can occur if the device sends a data packet in response to an IN request but then does not receive a handshake packet in a predetermined time. It can also occur if the device does not receive the data stage of an OUT transfer in time.

1: Timeout occurred

0: Timeout condition did not occur

Error Flag (Bit 2)

The Error Flag bit is set if a CRC5 and CRC16 error occurs, or if an incorrect packet type is received. Overflow and Underflow are not considered errors and do not affect this bit.

1: Error occurred

0: Error did not occur

ACK Flag (Bit 0)

The ACK Flag bit indicates whether the last transaction was ACKed.

1: ACK occurred

0: ACK did not occur

Device n Endpoint n Count Result Register [R/W]

- Device n Endpoint 0 Count Result Register [Device 1: 0x0208 Device 2: 0x0288]
- Device n Endpoint 1 Count Result Register [Device 1: 0x0218 Device 2: 0x0298]
- Device n Endpoint 2 Count Result Register [Device 1: 0x0228 Device 2: 0x02A8]
- Device n Endpoint 3 Count Result Register [Device 1: 0x0238 Device 2: 0x02B8]
- Device n Endpoint 4 Count Result Register [Device 1: 0x0248 Device 2: 0x02C8]
- Device n Endpoint 5 Count Result Register [Device 1: 0x0258 Device 2: 0x02D8]
- Device n Endpoint 6 Count Result Register [Device 1: 0x0268 Device 2: 0x02E8]
- Device n Endpoint 7 Count Result Register [Device 1: 0x0278 Device 2: 0x02F8]

Figure 34. Device n Endpoint n Count Result Register

Bit #	15	14	13	12	11	10	9	8
Field	Result...							
Read/Write	R/W	R/W	R/W	R/W	R/W	R/W	R/W	R/W
Default	X	X	X	X	X	X	X	X

Bit #	7	6	5	4	3	2	1	0
Field	...Result							
Read/Write	R/W	R/W	R/W	R/W	R/W	R/W	R/W	R/W
Default	X	X	X	X	X	X	X	X

Register Description

The Device n Endpoint n Count Result register contains the size difference in bytes between the Endpoint Count specified in the Device n Endpoint n Count register and the last packet received. If an overflow or underflow condition occurs, that is the received packet length differs from the value specified in the Device n Endpoint n Count register, the Length Exception Flag bit in the Device n Endpoint n Status register will be set. The value in this register is only considered when the Length Exception Flag bit is set and the Error Flag bit is not set; both bits are in the Device n Endpoint n Status register.

The Device n Endpoint n Count Result register is a memory based register that must be initialized to 0x0000 before USB Device operations are initiated. After initialization, this register must not be written to again.

Result (Bits [15:0])

The Result field contains the differences in bytes between the received packet and the value specified in the Device n Endpoint n Count register. If an overflow condition occurs, Result [15:10] is set to '111111', a 2's complement value indicating the additional byte count of the received packet. If an underflow condition occurs, Result [15:0] indicates the excess byte count (number of bytes not used).

Reserved

All reserved bits must be written as '0'.

Device n Interrupt Enable Register [R/W]

- Device 1 Interrupt Enable Register 0xC08C
- Device 2 Interrupt Enable Register 0xC0AC

Figure 35. Device n Interrupt Enable Register

Bit #	15	14	13	12	11	10	9	8
Field	VBUS Interrupt Enable	ID Interrupt Enable	Reserved		SOF/EOP Timeout Interrupt Enable	Reserved	SOF/EOP Interrupt Enable	Reset Interrupt Enable
Read/Write	R/W	R/W	-	-	R/W	-	R/W	R/W
Default	0	0	0	0	0	0	0	0

Bit #	7	6	5	4	3	2	1	0
Field	EP7 Interrupt Enable	EP6 Interrupt Enable	EP5 Interrupt Enable	EP4 Interrupt Enable	EP3 Interrupt Enable	EP2 Interrupt Enable	EP1 Interrupt Enable	EP0 Interrupt Enable
Read/Write	R/W	R/W	R/W	R/W	R/W	R/W	R/W	R/W
Default	0	0	0	0	0	0	0	0

Register Description

The Device n Interrupt Enable register provides control over device-related interrupts including eight different endpoint interrupts.

VBUS Interrupt Enable (Bit 15)

The VBUS Interrupt Enable bit enables or disables the OTG VBUS interrupt. When enabled this interrupt triggers on both the rising and falling edge of VBUS at the 4.4 V status (only supported in Port 1A). This bit is only available for Device 1 and is a reserved bit in Device 2.

- 1: Enable VBUS interrupt
- 0: Disable VBUS interrupt

ID Interrupt Enable (Bit 14)

The ID Interrupt Enable bit enables or disables the OTG ID interrupt. When enabled this interrupt triggers on both the rising and falling edge of the OTG ID pin (only supported in Port 1A). This bit is only available for Device 1 and is a reserved bit in Device 2.

- 1: Enable ID interrupt
- 0: Disable ID interrupt

SOF/EOP Timeout Interrupt Enable (Bit 11)

The SOF/EOP Timeout Interrupt Enable bit enables or disables the SOF/EOP Timeout Interrupt. When enabled this interrupt triggers when the USB host fails to send a SOF or EOP packet within the time period specified in the Device n SOF/EOP Count register. In addition, the Device n Frame register counts the number of times the SOF/EOP Timeout Interrupt triggers between receiving SOF/EOPs.

- 1: SOF/EOP timeout occurred
- 0: SOF/EOP timeout did not occur

SOF/EOP Interrupt Enable (Bit 9)

The SOF/EOP Interrupt Enable bit enables or disables the SOF/EOP received interrupt.

- 1: Enable SOF/EOP Received interrupt
- 0: Disable SOF/EOP Received interrupt

Reset Interrupt Enable (Bit 8)

The Reset Interrupt Enable bit enables or disables the USB Reset Detected interrupt

- 1: Enable USB Reset Detected interrupt
- 0: Disable USB Reset Detected interrupt

EP7 Interrupt Enable (Bit 7)

The EP7 Interrupt Enable bit enables or disables an endpoint seven (EP7) Transaction Done interrupt. An EPx Transaction Done interrupt triggers when any of the following responses or events occur in a transaction for the device's given Endpoint: send/receive ACK, send STALL, Timeout occurs, IN Exception Error, or OUT Exception Error. In addition, the NAK Interrupt Enable bit in the Device n Endpoint Control register can also be set so that NAK responses triggers this interrupt.

- 1: Enable EP7 Transaction Done interrupt
- 0: Disable EP7 Transaction Done interrupt

EP6 Interrupt Enable (Bit 6)

The EP6 Interrupt Enable bit enables or disables an endpoint six (EP6) Transaction Done interrupt. An EPx Transaction Done interrupt triggers when any of the following responses or events occur in a transaction for the device's given Endpoint: send/receive ACK, send STALL, Timeout occurs, IN Exception Error, or OUT Exception Error. In addition, the NAK Interrupt Enable bit in the Device n Endpoint Control register can also be set so that NAK responses triggers this interrupt.

- 1: Enable EP6 Transaction Done interrupt
- 0: Disable EP6 Transaction Done interrupt

EP5 Interrupt Enable (Bit 5)

The EP5 Interrupt Enable bit enables or disables an endpoint five (EP5) Transaction Done interrupt. An EPx Transaction Done interrupt triggers when any of the following responses or events occur in a transaction for the device's given Endpoint: send/receive ACK, send STALL, Timeout occurs, IN Exception Error, or OUT Exception Error. In addition, the NAK Interrupt Enable bit in the Device n Endpoint Control register can also be set so that NAK responses triggers this interrupt.

1: Enable EP5 Transaction Done interrupt

0: Disable EP5 Transaction Done interrupt

EP4 Interrupt Enable (Bit 4)

The EP4 Interrupt Enable bit enables or disables an endpoint four (EP4) Transaction Done interrupt. An EPx Transaction Done interrupt triggers when any of the following responses or events occur in a transaction for the device's given Endpoint: send/receive ACK, send STALL, Timeout occurs, IN Exception Error, or OUT Exception Error. In addition, the NAK Interrupt Enable bit in the Device n Endpoint Control register can also be set so that NAK responses triggers this interrupt.

1: Enable EP4 Transaction Done interrupt

0: Disable EP4 Transaction Done interrupt

EP3 Interrupt Enable (Bit 3)

The EP3 Interrupt Enable bit enables or disables an endpoint three (EP3) Transaction Done interrupt. An EPx Transaction Done interrupt triggers when any of the following responses or events occur in a transaction for the device's given Endpoint: send/receive ACK, send STALL, Timeout occurs, IN Exception Error, or OUT Exception Error. In addition, the NAK Interrupt Enable bit in the Device n Endpoint Control register can also be set so that NAK responses triggers this interrupt.

1: Enable EP3 Transaction Done interrupt

0: Disable EP3 Transaction Done interrupt

EP2 Interrupt Enable (Bit 2)

The EP2 Interrupt Enable bit enables or disables an endpoint two (EP2) Transaction Done interrupt. An EPx Transaction Done interrupt triggers when any of the following responses or events occur in a transaction for the device's given Endpoint: send/receive ACK, send STALL, Timeout occurs, IN Exception Error, or OUT Exception Error. In addition, the NAK Interrupt Enable bit in the Device n Endpoint Control register can also be set so that NAK responses triggers this interrupt.

1: Enable EP2 Transaction Done interrupt

0: Disable EP2 Transaction Done interrupt

EP1 Interrupt Enable (Bit 1)

The EP1 Interrupt Enable bit enables or disables an endpoint one (EP1) Transaction Done interrupt. An EPx Transaction Done interrupt triggers when any of the following responses or events occur in a transaction for the device's given Endpoint: send/receive ACK, send STALL, Timeout occurs, IN Exception Error, or OUT Exception Error. In addition, the NAK Interrupt Enable bit in the Device n Endpoint Control register can also be set so that NAK responses triggers this interrupt.

1: Enable EP1 Transaction Done interrupt

0: Disable EP1 Transaction Done interrupt

EP0 Interrupt Enable (Bit 0)

The EP0 Interrupt Enable bit enables or disables an endpoint zero (EP0) Transaction Done interrupt. An EPx Transaction Done interrupt triggers when any of the following responses or events occur in a transaction for the device's given Endpoint: send/receive ACK, send STALL, Timeout occurs, IN Exception Error, or OUT Exception Error. In addition, the NAK Interrupt Enable bit in the Device n Endpoint Control register can also be set so that NAK responses triggers this interrupt.

1: Enable EP0 Transaction Done interrupt

0: Disable EP0 Transaction Done interrupt

Reserved

All reserved bits must be written as '0'.

Device n Address Register [W]

- Device 1 Address Register 0xC08E
- Device 2 Address Register 0xC0AE

Figure 36. Device n Address Register

Bit #	15	14	13	12	11	10	9	8
Field	Reserved...							
Read/Write	-	-	-	-	-	-	-	-
Default	0	0	0	0	0	0	0	0

Bit #	7	6	5	4	3	2	1	0
Field	...Reserved	Address						
Read/Write	-	W	W	W	W	W	W	W
Default	0	0	0	0	0	0	0	0

Register Description

The Device n Address register holds the device address assigned by the host. This register initializes to the default address 0 at reset but must be updated by firmware when the host assigns a new address. Only USB data sent to the address contained in this register will be responded to, all others are ignored.

Address (Bits [6:0])

The Address field contains the USB address of the device assigned by the host.

Reserved

All reserved bits must be written as '0'.

Device n Status Register [R/W]

- Device 1 Status Register 0xC090
- Device 2 Status Register 0xC0B0

Figure 37. Device n Status Register

Bit #	15	14	13	12	11	10	9	8
Field	VBUS Interrupt Flag	ID Interrupt Flag	Reserved				SOF/EOP Interrupt Flag	Reset Interrupt Flag
Read/Write	R/W	R/W	-	-	-	-	R/W	R/W
Default	X	X	X	X	X	X	X	X

Bit #	7	6	5	4	3	2	1	0
Field	EP7 Interrupt Flag	EP6 Interrupt Flag	EP5 Interrupt Flag	EP4 Interrupt Flag	EP3 Interrupt Flag	EP2 Interrupt Flag	EP1 Interrupt Flag	EP0 Interrupt Flag
Read/Write	R/W	R/W	R/W	R/W	R/W	R/W	R/W	R/W
Default	X	X	X	X	X	X	X	X

Register Description

The Device n Status register provides status information for device operation. Pending interrupts can be cleared by writing a '1' to the corresponding bit. This register can be accessed by the HPI interface.

VBUS Interrupt Flag (Bit 15)

The VBUS Interrupt Flag bit indicates the status of the OTG VBUS interrupt (only for Port 1A). When enabled this interrupt triggers on both the rising and falling edge of VBUS at 4.4 V. This bit is only available for Device 1 and is a reserved bit in Device 2.

- 1: Interrupt triggered
- 0: Interrupt did not trigger

ID Interrupt Flag (Bit 14)

The ID Interrupt Flag bit indicates the status of the OTG ID interrupt (only for Port 1A). When enabled this interrupt triggers on both the rising and falling edge of the OTG ID pin. This bit is only available for Device 1 and is a reserved bit in Device 2.

- 1: Interrupt triggered
- 0: Interrupt did not trigger

SOF/EOP Interrupt Flag (Bit 9)

The SOF/EOP Interrupt Flag bit indicates if the SOF/EOP received interrupt has triggered.

- 1: Interrupt triggered

0: Interrupt did not trigger

Reset Interrupt Flag (Bit 8)

The Reset Interrupt Flag bit indicates if the USB Reset Detected interrupt has triggered.

1: Interrupt triggered

0: Interrupt did not trigger

EP7 Interrupt Flag (Bit 7)

The EP7 Interrupt Flag bit indicates if the endpoint seven (EP7) Transaction Done interrupt has triggered. An EPx Transaction Done interrupt triggers when any of the following responses or events occur in a transaction for the device's given EP: send/receive ACK, send STALL, Timeout occurs, IN Exception Error, or OUT Exception Error. In addition, if the NAK Interrupt Enable bit in the Device n Endpoint Control register is set, this interrupt also triggers when the device NAKs host requests.

1: Interrupt triggered

0: Interrupt did not trigger

EP6 Interrupt Flag (Bit 6)

The EP6 Interrupt Flag bit indicates if the endpoint six (EP6) Transaction Done interrupt has triggered. An EPx Transaction Done interrupt triggers when any of the following responses or events occur in a transaction for the device's given EP: send/receive ACK, send STALL, Timeout occurs, IN Exception Error, or OUT Exception Error. In addition, if the NAK Interrupt Enable bit in the Device n Endpoint Control register is set, this interrupt also triggers when the device NAKs host requests.

1: Interrupt triggered

0: Interrupt did not trigger

EP5 Interrupt Flag (Bit 5)

The EP5 Interrupt Flag bit indicates if the endpoint five (EP5) Transaction Done interrupt has triggered. An EPx Transaction Done interrupt triggers when any of the following responses or events occur in a transaction for the device's given EP: send/receive ACK, send STALL, Timeout occurs, IN Exception Error, or OUT Exception Error. In addition, if the NAK Interrupt Enable bit in the Device n Endpoint Control register is set, this interrupt also triggers when the device NAKs host requests.

1: Interrupt triggered

0: Interrupt did not trigger

EP4 Interrupt Flag (Bit 4)

The EP4 Interrupt Flag bit indicates if the endpoint four (EP4) Transaction Done interrupt has triggered. An EPx Transaction Done interrupt triggers when any of the following responses or events occur in a transaction for the device's given EP: send/receive ACK, send STALL, Timeout occurs, IN Exception Error, or OUT Exception Error. In addition, if the NAK Interrupt Enable bit in the Device n Endpoint Control register is set, this interrupt also triggers when the device NAKs host requests.

1: Interrupt triggered

0: Interrupt did not trigger

EP3 Interrupt Flag (Bit 3)

The EP3 Interrupt Flag bit indicates if the endpoint three (EP3) Transaction Done interrupt has triggered. An EPx Transaction Done interrupt triggers when any of the following responses or events occur in a transaction for the device's given EP: send/receive ACK, send STALL, Timeout occurs, IN Exception Error, or OUT Exception Error. In addition, if the NAK Interrupt Enable bit in the Device n Endpoint Control register is set, this interrupt also triggers when the device NAKs host requests.

1: Interrupt triggered

0: Interrupt did not trigger

EP2 Interrupt Flag (Bit 2)

The EP2 Interrupt Flag bit indicates if the endpoint two (EP2) Transaction Done interrupt has triggered. An EPx Transaction Done interrupt triggers when any of the following responses or events occur in a transaction for the device's given EP: send/receive ACK, send STALL, Timeout occurs, IN Exception Error, or OUT Exception Error. In addition, if the NAK Interrupt Enable bit in the Device n Endpoint Control register is set, this interrupt also triggers when the device NAKs host requests.

1: Interrupt triggered

0: Interrupt did not trigger

EP1 Interrupt Flag (Bit 1)

The EP1 Interrupt Flag bit indicates if the endpoint one (EP1) Transaction Done interrupt has triggered. An EPx Transaction Done interrupt triggers when any of the following responses or events occur in a transaction for the device's given EP: send/receive ACK, send STALL, Timeout occurs, IN Exception Error, or OUT Exception Error. In addition, if the NAK Interrupt Enable bit in the Device n Endpoint Control register is set, this interrupt also triggers when the device NAKs host requests.

1: Interrupt triggered

0: Interrupt did not trigger

EP0 Interrupt Flag (Bit 0)

The EP0 Interrupt Flag bit indicates if the endpoint zero (EP0) Transaction Done interrupt has triggered. An EPx Transaction Done interrupt triggers when any of the following responses or events occur in a transaction for the device's given EP: send/receive ACK, send STALL, Timeout occurs, IN Exception Error, or OUT Exception Error. In addition, if the NAK Interrupt Enable bit in the Device n Endpoint Control register is set, this interrupt also triggers when the device NAKs host requests.

1: Interrupt triggered

0: Interrupt did not trigger

Reserved

All reserved bits must be written as '0'.

Device n Frame Number Register [R]

- Device 1 Frame Number Register 0xC092
- Device 2 Frame Number Register 0xC0B2

Figure 38. Device n Frame Number Register

Bit #	15	14	13	12	11	10	9	8
Field	SOF/EOP Timeout Flag	SOF/EOP Timeout Interrupt Counter			Reserved	Frame...		
Read/Write	R	R	R	R	-	R	R	R
Default	0	0	0	0	0	0	0	0

Bit #	7	6	5	4	3	2	1	0
Field	...Frame							
Read/Write	R	R	R	R	R	R	R	R
Default	0	0	0	0	0	0	0	0

Register Description

The Device n Frame Number register is a read only register that contains the Frame number of the last SOF packet received. This register also contains a count of SOF/EOP Timeout occurrences.

SOF/EOP Timeout Flag (Bit 15)

The SOF/EOP Timeout Flag bit indicates when an SOF/EOP Timeout Interrupt occurs.

- 1: An SOF/EOP Timeout interrupt occurred
- 0: An SOF/EOP Timeout interrupt did not occur

SOF/EOP Timeout Interrupt Counter (Bits [14:12])

Device n SOF/EOP Count Register [W]

- Device 1 SOF/EOP Count Register 0xC094
- Device 2 SOF/EOP Count Register 0xC0B4

Figure 39. Device n SOF/EOP Count Register

Bit #	15	14	13	12	11	10	9	8
Field	Reserved		Count...					
Read/Write	-	-	R	R	R	R	R	R
Default	0	0	1	0	1	1	1	0

Bit #	7	6	5	4	3	2	1	0
Field	...Count							
Read/Write	R	R	R	R	R	R	R	R
Default	1	1	1	0	0	0	0	0

The SOF/EOP Timeout Interrupt Counter field increments by 1 from 0 to 7 for each SOF/EOP Timeout Interrupt. This field resets to 0 when a SOF/EOP is received. This field is only updated when the SOF/EOP Timeout Interrupt Enable bit in the Device n Interrupt Enable register is set.

Frame (Bits [10:0])

The Frame field contains the frame number from the last received SOF packet in full speed mode. This field has no function for low-speed mode. If a SOF Timeout occurs, this field contains the last received Frame number.

Register Description

The Device n SOF/EOP Count register must be written with the time expected between receiving a SOF/EOPs. If the SOF/EOP counter expires before an SOF/EOP is received, an SOF/EOP Timeout Interrupt can be generated. The SOF/EOP Timeout Interrupt Enable and SOF/EOP Timeout Interrupt Flag are located in the Device n Interrupt Enable and Status registers, respectively.

The SOF/EOP count must be set slightly greater than the expected SOF/EOP interval. The SOF/EOP counter decrements at a 12-MHz rate. Therefore in the case of an expected 1-ms SOF/EOP interval, the SOF/EOP count must be set slightly greater than 0x2EE0.

Count (Bits [13:0])

The Count field contains the current value of the SOF/EOP down counter. At power-up and reset, this value is set to 0x2EE0 and for expected 1-ms SOF/EOP intervals, this SOF/EOP count should be increased slightly.

Reserved

All reserved bits must be written as '0'.

OTG Control Registers

There is one register dedicated for OTG operation. This register is covered in this section and summarized in [Table 28](#).

Table 28. OTG Registers

Register Name ^[9]	Address	R/W
OTG Control Register	C098H	R/W

OTG Control Register [0xC098] [R/W]

Figure 40. OTG Control Register

Bit #	15	14	13	12	11	10	9	8
Field	Reserved		VBUS Pull-up Enable	Receive Disable	Charge Pump Enable	VBUS Discharge Enable	D+ Pull-up Enable	D- Pull-up Enable
Read/Write	-	-	R/W	R/W	R/W	R/W	R/W	R/W
Default	0	0	0	0	0	0	0	0

Bit #	7	6	5	4	3	2	1	0
Field	D+ Pull-down Enable	D- Pull-down Enable	Reserved			OTG Data Status	ID Status	VBUS Valid Flag
Read/Write	R/W	R/W	-	-	-	R	R	R
Default	0	0	0	0	0	X	X	X

Register Description

The OTG Control register allows control and monitoring over the OTG port on Port1A.

VBUS Pull-up Enable (Bit 13)

The VBUS Pull-up Enable bit enables or disables a 500 ohm pull-up resistor onto OTG VBus.

- 1: 500 ohm pull-up resistor enabled
- 0: 500 ohm pull-up resistor disabled

Receive Disable (Bit 12)

The Receive Disable bit enables or powers down (disables) the OTG receiver section.

- 1: OTG receiver powered down and disabled
- 0: OTG receiver enabled

Charge Pump Enable (Bit 11)

The Charge Pump Enable bit enables or disables the OTG VBus charge pump.

- 1: OTG VBus charge pump enabled

0: OTG VBus charge pump disabled

VBUS Discharge Enable (Bit 10)

The VBUS Discharge Enable bit enables or disables a 2K-ohm discharge pull-down resistor onto OTG VBus.

- 1: 2K-ohm pull-down resistor enabled
- 0: 2K-ohm pull-down resistor disabled

D+ Pull-up Enable (Bit 9)

The D+ Pull-up Enable bit enables or disables a pull-up resistor on the OTG D+ data line.

- 1: OTG D+ dataline pull-up resistor enabled
- 0: OTG D+ dataline pull-up resistor disabled

D- Pull-up Enable (Bit 8)

The D- Pull-up Enable bit enables or disables a pull-up resistor on the OTG D- data line.

- 1: OTG D- dataline pull-up resistor enabled
- 0: OTG D- dataline pull-up resistor disabled

Note

9. **Errata:** The VBUS interrupt in the Host/Device Status Registers [0xC090 and 0xC0B0] and OTG Control Register [0xC098] triggers multiple times whenever VBUS is turned on. It should only trigger once when VBUS rises above 4.4 V and once when VBUS falls from above 4.4 V to 0 V. For more information, see the [Errata on page 84](#).

D+ Pull-down Enable (Bit 7)

The D+ Pull-down Enable bit enables or disables a pull-down resistor on the OTG D+ data line.

- 1: OTG D+ dataline pull-down resistor enabled
- 0: OTG D+ dataline pull-down resistor disabled

D– Pull-down Enable (Bit 6)

The D– Pull-down Enable bit enables or disables a pull-down resistor on the OTG D– data line.

- 1: OTG D– dataline pull-down resistor enabled
- 0: OTG D– dataline pull-down resistor disabled

OTG Data Status (Bit 2)

The OTG Data Status bit is a read only bit and indicates the TTL logic state of the OTG VBus pin.

- 1: OTG VBus is greater than 2.4 V

- 0: OTG VBus is less than 0.8 V

ID Status (Bit 1)

The ID Status bit is a read only bit that indicates the state of the OTG ID pin on Port A.

- 1: OTG ID Pin is not connected directly to ground (>10K ohm)
- 0: OTG ID Pin is connected directly ground (< 10 ohm)

VBUS Valid Flag (Bit 0)

The VBUS Valid Flag bit indicates whether OTG VBus is greater than 4.4 V. After turning on VBUS, firmware should wait at least 10 μs before this reading this bit.

- 1: OTG VBus is greater then 4.4 V
- 0: OTG VBus is less then 4.4 V

Reserved

All reserved bits must be written as '0'.

GPIO Registers

There are seven registers dedicated for GPIO operations. These seven registers are covered in this section and summarized in [Table 29](#).

Table 29. GPIO Registers

Register Name	Address	R/W
GPIO Control Register	0xC006	R/W
GPIO0 Output Data Register	0xC01E	R/W
GPIO0 Input Data Register	0xC020	R
GPIO0 Direction Register	0xC022	R/W
GPIO1 Output Data Register	0xC024	R/W
GPIO1 Input Data Register	0xC026	R
GPIO1 Direction Register	0xC028	R/W

GPIO Control Register [0xC006] [R/W]

Figure 41. GPIO Control Register

Bit #	15	14	13	12	11	10	9	8
Field	Write Protect Enable	Reserved	Reserved		SAS Enable	Mode Select		
Read/Write	R/W	-	R	-	R/W	R/W	R/W	R/W
Default	0	0	0	0	0	0	0	0

Bit #	7	6	5	4	3	2	1	0
Field	HSS Enable	Reserved	SPI Enable	Reserved			Interrupt 0 Polarity Select	Interrupt 0 Enable
Read/Write	R/W	-	R/W	-	-	-	R/W	R/W
Default	0	0	0	0	0	0	0	0

Register Description

The GPIO Control register configures the GPIO pins for various interface options. It also controls the polarity of the GPIO interrupt on IRQ0 (GPIO24).

Write Protect Enable (Bit 15)

The Write Protect Enable bit enables or disables the GPIO write protect. When Write Protect is enabled, the GPIO Mode Select [15:8] bits are read-only until a chip reset.

- 1: Enable Write Protect
- 0: Disable Write Protect

SAS Enable (Bit 11)

The SAS Enable bit, when in SPI mode, reroutes the SPI port SPI_nSSI pin to GPIO[15] rather than GPIO[9].

- 1: Reroute SPI_nss to GPIO[15]
- 0: Leave SPI_nss on GPIO[9]

Mode Select (Bits [10:8])

The Mode Select field selects how GPIO[15:0] and GPIO[24:19] are used as defined in Table 30.

Table 30. Mode Select Definition

Mode Select [10:8]	GPIO Configuration
111	Reserved
110	SCAN – (HW) Scan diagnostic. For production test only. Not for normal operation
101	HPI – Host Port Interface
100	Reserved
011	Reserved
010	Reserved
001	Reserved

Table 30. Mode Select Definition (continued)

Mode Select [10:8]	GPIO Configuration
000	GPIO – General Purpose Input Output

HSS Enable (Bit 7)

The HSS Enable bit routes HSS to GPIO[15:12].

- 1: HSS is routed to GPIO
- 0: HSS is not routed to GPIOs. GPIO[15:12] are free for other purposes.

SPI Enable (Bit 5)

The SPI Enable bit routes SPI to GPIO[11:8]. If the SAS Enable bit is set, it overrides and routes the SPI_nSSI pin to GPIO15.

- 1: SPI is routed to GPIO[11:8]
- 0: SPI is not routed to GPIO[11:8]. GPIO[11:8] are free for other purposes.

Interrupt 0 Polarity Select (Bit 1)

The Interrupt 0 Polarity Select bit selects the polarity for IRQ0.

- 1: Sets IRQ0 to rising edge
- 0: Sets IRQ0 to falling edge

Interrupt 0 Enable (Bit 0)

The Interrupt 0 Enable bit enables or disables IRQ0. The GPIO bit on the interrupt Enable register must also be set in order for this for this interrupt to be enabled.

- 1: Enable IRQ0
- 0: Disable IRQ0

Reserved

All reserved bits must be written as '0'.

GPIO 0 Output Data Register [0xC01E] [R/W]

Figure 42. GPIO 0 Output Data Register

Bit #	15	14	13	12	11	10	9	8
Field	GPIO15	GPIO14	GPIO13	GPIO12	GPIO11	GPIO10	GPIO9	GPIO8
Read/Write	R/W	R/W	R/W	R/W	R/W	R/W	R/W	R/W
Default	0	0	0	0	0	0	0	0

Bit #	7	6	5	4	3	2	1	0
Field	GPIO7	GPIO6	GPIO5	GPIO4	GPIO3	GPIO2	GPIO1	GPIO0
Read/Write	R/W	R/W	R/W	R/W	R/W	R/W	R/W	R/W
Default	0	0	0	0	0	0	0	0

Register Description

The GPIO 0 Output Data register controls the output data of the GPIO pins. The GPIO 0 Output Data register controls GPIO15 to GPIO0 while the GPIO 1 Output Data register controls GPIO31 to GPIO19. When read, this register reads back the last data written, not the data on pins configured as inputs (see Input Data Register).

Writing a 1 to any bit will output a high voltage on the corresponding GPIO pin.

Reserved

All reserved bits must be written as '0'.

GPIO 1 Output Data Register [0xC024] [R/W]

Figure 43. GPIO n Output Data Register

Bit #	15	14	13	12	11	10	9	8
Field	GPIO31	GPIO30	GPIO29	Reserved				GPIO24
Read/Write	R/W	R/W	R/W	-	-	-	-	R/W
Default	0	0	0	0	0	0	0	0

Bit #	7	6	5	4	3	2	1	0
Field	GPIO23	GPIO22	GPIO21	GPIO20	GPIO19	Reserved		
Read/Write	R/W	R/W	R/W	R/W	R/W	-	-	-
Default	0	0	0	0	0	0	0	0

Register Description

The GPIO 1 Output Data register controls the output data of the GPIO pins. The GPIO 0 Output Data register controls GPIO15 to GPIO0 while the GPIO 1 Output Data register controls GPIO31 to GPIO19. When read, this register reads back the last data written, not the data on pins configured as inputs (see Input Data Register).

Writing a 1 to any bit will output a high voltage on the corresponding GPIO pin.

Reserved

All reserved bits must be written as '0'.

GPIO 0 Input Data Register [0xC020] [R]

Figure 44. GPIO 0 Input Data Register

Bit #	15	14	13	12	11	10	9	8
Field	GPIO15	GPIO14	GPIO13	GPIO12	GPIO11	GPIO10	GPIO9	GPIO8
Read/Write	R	R	R	R	R	R	R	R
Default	0	0	0	0	0	0	0	0

Bit #	7	6	5	4	3	2	1	0
Field	GPIO7	GPIO6	GPIO5	GPIO4	GPIO3	GPIO2	GPIO1	GPIO0
Read/Write	R	R	R	R	R	R	R	R
Default	0	0	0	0	0	0	0	0

Register Description

The GPIO 0 Input Data register reads the input data of the GPIO pins. The GPIO 0 Input Data register reads from GPIO15 to GPIO0 while the GPIO 1 Input Data register reads from GPIO31 to GPIO19.

Every bit represents the voltage of that GPIO pin.

GPIO 1 Input Data Register [0xC026] [R]

Figure 45. GPIO 1 Input Data Register

Bit #	15	14	13	12	11	10	9	8
Field	GPIO31	GPIO30	GPIO29	Reserved				GPIO24
Read/Write	R	R	R	-	-	-	-	R
Default	0	0	0	0	0	0	0	0

Bit #	7	6	5	4	3	2	1	0
Field	GPIO23	GPIO22	GPIO21	GPIO20	GPIO19	Reserved		
Read/Write	R	R	R	R	R	-	-	-
Default	0	0	0	0	0	0	0	0

Register Description

The GPIO 1 Input Data register reads the input data of the GPIO pins. The GPIO 0 Input Data register reads from GPIO15 to GPIO0 while the GPIO 1 Input Data register reads from GPIO31 to GPIO19.

Every bit represents the voltage of that GPIO pin.

GPIO 0 Direction Register [0xC022] [R/W]

Figure 46. GPIO 0 Direction Register

Bit #	15	14	13	12	11	10	9	8
Field	GPIO15	GPIO14	GPIO13	GPIO12	GPIO11	GPIO10	GPIO9	GPIO8
Read/Write	R/W	R/W	R/W	R/W	R/W	R/W	R/W	R/W
Default	0	0	0	0	0	0	0	0

Bit #	7	6	5	4	3	2	1	0
Field	GPIO7	GPIO6	GPIO5	GPIO4	GPIO3	GPIO2	GPIO1	GPIO0
Read/Write	R/W	R/W	R/W	R/W	R/W	R/W	R/W	R/W
Default	0	0	0	0	0	0	0	0

Register Description

The GPIO 0 Direction register controls the direction of the GPIO data pins (input/output). The GPIO 0 Direction register controls GPIO15 to GPIO0 while the GPIO 1 Direction register controls GPIO31 to GPIO19.

When any bit of this register is set to '1', the corresponding GPIO data pin becomes an output. When any bit of this register is set to '0', the corresponding GPIO data pin becomes an input.

Reserved

All reserved bits must be written as '0'.

GPIO 1 Direction Register [0xC028] [R/W]

Figure 47. GPIO 1 Direction Register

Bit #	15	14	13	12	11	10	9	8
Field	GPIO31	GPIO30	GPIO29	Reserved				GPIO24
Read/Write	R/W	R/W	R/W	R/W	R/W	R/W	R/W	R/W
Default	0	0	0	0	0	0	0	0

Bit #	7	6	5	4	3	2	1	0
Field	GPIO23	GPIO22	GPIO21	GPIO20	GPIO19	Reserved		
Read/Write	R/W	R/W	R/W	R/W	R/W	R/W	R/W	R/W
Default	0	0	0	0	0	0	0	0

Register Description

The GPIO 1 Direction register controls the direction of the GPIO data pins (input/output). The GPIO 0 Direction register controls GPIO15 to GPIO0 while the GPIO 1 Direction register controls GPIO31 to GPIO19.

When any bit of this register is set to '1', the corresponding GPIO data pin becomes an output. When any bit of this register is set to '0', the corresponding GPIO data pin becomes an input.

Reserved

All reserved bits must be written as '0'.

HSS Registers

There are eight registers dedicated to HSS operation. Each of these registers are covered in this section and summarized in [Table 31](#).

Table 31. HSS Registers

Register Name	Address	R/W
HSS Control Register	0xC070	R/W
HSS Baud Rate Register	0xC072	R/W
HSS Transmit Gap Register	0xC074	R/W
HSS Data Register	0xC076	R/W
HSS Receive Address Register	0xC078	R/W
HSS Receive Length Register	0xC07A	R/W
HSS Transmit Address Register	0xC07C	R/W
HSS Transmit Length Register	0xC07E	R/W

HSS Control Register [0xC070] [R/W]

Figure 48. HSS Control Register

Bit #	15	14	13	12	11	10	9	8
Field	HSS Enable	RTS Polarity Select	CTS Polarity Select	XOFF	XOFF Enable	CTS Enable	Receive Interrupt Enable	Done Interrupt Enable
Read/Write	R/W	R/W	R/W	R	R/W	R/W	R/W	R/W
Default	0	0	0	0	0	0	0	0

Bit #	7	6	5	4	3	2	1	0
Field	Transmit Done Interrupt Enable	Receive Done Interrupt Enable	One Stop Bit	Transmit Ready	Packet Mode Select	Receive Overflow Flag	Receive Packet Ready Flag	Receive Ready Flag
Read/Write	R/W	R/W	R/W	R	R/W	R/W	R	R
Default	0	0	0	0	0	0	0	0

Register Description

The HSS Control register provides high-level status and control over the HSS port.

HSS Enable (Bit 15)

The HSS Enable bit enables or disables HSS operation.

- 1: Enables HSS operation
- 0: Disables HSS operation

RTS Polarity Select (Bit 14)

The RTS Polarity Select bit selects the polarity of RTS.

- 1: RTS is true when LOW
- 0: RTS is true when HIGH

CTS Polarity Select (Bit 13)

The CTS Polarity Select bit selects the polarity of CTS.

- 1: CTS is true when LOW
- 0: CTS is true when HIGH

XOFF (Bit 12)

The XOFF bit is a read-only bit that indicates if an XOFF has been received. This bit is automatically cleared when an XON is received.

- 1: XOFF received
- 0: XON received

XOFF Enable (Bit 11)

The XOFF Enable bit enables or disables XON/XOFF software handshaking.

- 1: Enable XON/XOFF software handshaking
- 0: Disable XON/XOFF software handshaking

CTS Enable (Bit 10)

The CTS Enable bit enables or disables CTS/RTS hardware handshaking.

- 1: Enable CTS/RTS hardware handshaking
- 0: Disable CTS/RTS hardware handshaking

Receive Interrupt Enable (Bit 9)

The Receive Interrupt Enable bit enables or disables the Receive Ready and Receive Packet Ready interrupts.

- 1: Enable the Receive Ready and Receive Packet Ready interrupts
- 0: Disable the Receive Ready and Receive Packet Ready interrupts

Done Interrupt Enable (Bit 8)

The Done Interrupt Enable bit enables or disables the Transmit Done and Receive Done interrupts.

- 1: Enable the Transmit Done and Receive Done interrupts
- 0: Disable the Transmit Done and Receive Done interrupts

Transmit Done Interrupt Flag (Bit 7)

The Transmit Done Interrupt Flag bit indicates the status of the Transmit Done Interrupt. It will set when a block transmit is finished. To clear the interrupt, a '1' must be written to this bit.

- 1: Interrupt triggered
- 0: Interrupt did not trigger

Receive Done Interrupt Flag (Bit 6)

The Receive Done Interrupt Flag bit indicates the status of the Receive Done Interrupt. It will set when a block transmit is finished. To clear the interrupt, a '1' must be written to this bit.

- 1: Interrupt triggered
- 0: Interrupt did not trigger

One Stop Bit (Bit 5)

The One Stop Bit bit selects between one and two stop bits for transmit byte mode. In receive mode, the number of stop bits may vary and does not need to be fixed.

- 1: One stop bit
- 0: Two stop bits

Transmit Ready (Bit 4)

The Transmit Ready bit is a read only bit that indicates if the HSS Transmit FIFO is ready for the CPU to load new data for transmission.

- 1: HSS transmit FIFO ready for loading
- 0: HSS transmit FIFO not ready for loading

Packet Mode Select (Bit 3)

The Packet Mode Select bit selects between Receive Packet Ready and Receive Ready as the interrupt source for the RxIntr interrupt.

- 1: Selects Receive Packet Ready as the source
- 0: Selects Receive Ready as the source

Receive Overflow Flag (Bit 2)

The Receive Overflow Flag bit indicates if the Receive FIFO overflowed when set. This flag can be cleared by writing a '1' to this bit.

- 1: Overflow occurred
- 0: Overflow did not occur

HSS Baud Rate Register [0xC072] [R/W]

Figure 49. HSS Baud Rate Register

Bit #	15	14	13	12	11	10	9	8
Field	Reserved			Baud...				
Read/Write	-	-	-	R/W	R/W	R/W	R/W	R/W
Default	0	0	0	0	0	0	0	0

Bit #	7	6	5	4	3	2	1	0
Field	...Baud							
Read/Write	R/W	R/W	R/W	R/W	R/W	R/W	R/W	R/W
Default	0	0	0	1	0	1	1	1

Receive Packet Ready Flag (Bit 1)

The Receive Packet Ready Flag bit is a read only bit that indicates if the HSS receive FIFO is full with eight bytes.

- 1: HSS receive FIFO is full
- 0: HSS receive FIFO is not full

Receive Ready Flag (Bit 0)

The Receive Ready Flag is a read only bit that indicates if the HSS receive FIFO is empty.

- 1: HSS receive FIFO is not empty (one or more bytes is reading for reading)
- 0: HSS receive FIFO is empty

Register Description

The HSS Baud Rate register sets the HSS Baud Rate. At reset, the default value is 0x0017 which sets the baud rate to 2.0 MHz.

Baud (Bits [12:0])

The Baud field is the baud rate divisor minus one, in units of 1/48 MHz. Therefore the Baud Rate = 48 MHz/(Baud + 1). This puts a constraint on the Baud Value as follows: $(24 - 1) \leq \text{Baud} \leq (5000 - 1)$

Reserved

All reserved bits must be written as '0'.

HSS Transmit Gap Register [0xC074] [R/W]

Figure 50. HSS Transmit Gap Register

Bit #	15	14	13	12	11	10	9	8
Field	Reserved							
Read/Write	-	-	-	-	-	-	-	-
Default	0	0	0	0	0	0	0	0

Bit #	7	6	5	4	3	2	1	0
Field	Transmit Gap Select							
Read/Write	R/W	R/W	R/W	R/W	R/W	R/W	R/W	R/W
Default	0	0	0	0	1	0	0	1

Register Description

The HSS Transmit Gap register is only valid in block transmit mode. It allows for a programmable number of stop bits to be inserted thus overwriting the One Stop Bit in the HSS Control register. The default reset value of this register is 0x0009, equivalent to two stop bits.

Transmit Gap Select (Bits [7:0])

The Transmit Gap Select field sets the inactive time between transmitted bytes. The inactive time = (Transmit Gap Select – 7) * bit time. Therefore an Transmit Gap Select Value of 8 is equal to having one Stop bit.

Reserved

All reserved bits must be written as '0'.

HSS Data Register [0xC076] [R/W]

Figure 51. HSS Data Register

Bit #	15	14	13	12	11	10	9	8
Field	Reserved							
Read/Write	-	-	-	-	-	-	-	-
Default	X	X	X	X	X	X	X	X

Bit #	7	6	5	4	3	2	1	0
Field	Data							
Read/Write	R/W	R/W	R/W	R/W	R/W	R/W	R/W	R/W
Default	X	X	X	X	X	X	X	X

Register Description

The HSS Data register contains data received on the HSS port (not for block receive mode) when read. This receive data is valid when the Receive Ready bit of the HSS Control register is set to '1'. Writing to this register initiates a single byte transfer of data. The Transmit Ready Flag in the HSS Control register must read '1' before writing to this register (this avoids disrupting the previous/current transmission).

Data (Bits [7:0])

The Data field contains the data received or to be transmitted on the HSS port.

Reserved

All reserved bits must be written as '0'.

HSS Receive Address Register [0xC078] [R/W]

Figure 52. HSS Receive Address Register

Bit #	15	14	13	12	11	10	9	8
Field	Address...							
Read/Write	R/W	R/W	R/W	R/W	R/W	R/W	R/W	R/W
Default	0	0	0	0	0	0	0	0
Bit #	7	6	5	4	3	2	1	0
Field	...Address							
Read/Write	R/W	R/W	R/W	R/W	R/W	R/W	R/W	R/W
Default	0	0	0	0	0	0	0	0

Register Description

The HSS Receive Address register is used as the base pointer address for the next HSS block receive transfer.

Address (Bits [15:0])

The Address field sets the base pointer address for the next HSS block receive transfer.

HSS Receive Counter Register [0xC07A] [R/W]

Figure 53. HSS Receive Counter Register

Bit #	15	14	13	12	11	10	9	8
Field	Reserved						Counter...	
Read/Write	-	-	-	-	-	-	R/W	R/W
Default	0	0	0	0	0	0	0	0
Bit #	7	6	5	4	3	2	1	0
Field	...Counter							
Read/Write	R/W	R/W	R/W	R/W	R/W	R/W	R/W	R/W
Default	0	0	0	0	0	0	0	0

Register Description

The HSS Receive Counter register designates the block byte length for the next HSS receive transfer. This register must be loaded with the word count minus one to start the block receive transfer. As each byte is received this register value is decremented. When read, this register indicates the remaining length of the transfer.

Counter (Bits [9:0])

The Counter field value is equal to the word count minus one giving a maximum value of 0x03FF (1023) or 2048 bytes. When the transfer is complete this register returns 0x03FF until reloaded.

Reserved

All reserved bits must be written as '0'.

HSS Transmit Address Register [0xC07C] [R/W]

Figure 54. HSS Transmit Address Register

Bit #	15	14	13	12	11	10	9	8
Field	Address...							
Read/Write	R/W	R/W	R/W	R/W	R/W	R/W	R/W	R/W
Default	0	0	0	0	0	0	0	0

Bit #	7	6	5	4	3	2	1	0
Field	...Address							
Read/Write	R/W	R/W	R/W	R/W	R/W	R/W	R/W	R/W
Default	0	0	0	0	0	0	0	0

Register Description

The HSS Transmit Address register is used as the base pointer address for the next HSS block transmit transfer.

Address (Bits [15:0])

The Address field sets the base pointer address for the next HSS block transmit transfer.

HSS Transmit Counter Register [0xC07E] [R/W]

Figure 55. HSS Transmit Counter Register

Bit #	15	14	13	12	11	10	9	8
Field	Reserved						Counter...	
Read/Write	-	-	-	-	-	-	R/W	R/W
Default	0	0	0	0	0	0	0	0

Bit #	7	6	5	4	3	2	1	0
Field	...Counter							
Read/Write	R/W	R/W	R/W	R/W	R/W	R/W	R/W	R/W
Default	0	0	0	0	0	0	0	0

Register Description

The HSS Transmit Counter register designates the block byte length for the next HSS transmit transfer. This register must be loaded with the word count minus one to start the block transmit transfer. As each byte is transmitted this register value is decremented. When read, this register indicates the remaining length of the transfer.

Counter (Bits [9:0])

The Counter field value is equal to the word count minus one giving a maximum value of 0x03FF (1023) or 2048 bytes. When the transfer is complete this register returns 0x03FF until reloaded.

Reserved

All reserved bits must be written as '0'.

HPI Breakpoint Register [0x0140] [R]

Figure 56. HPI Breakpoint Register

Bit #	15	14	13	12	11	10	9	8
Field	Address...							
Read/Write	R	R	R	R	R	R	R	R
Default	0	0	0	0	0	0	0	0

Bit #	7	6	5	4	3	2	1	0
Field	...Address							
Read/Write	R	R	R	R	R	R	R	R
Default	0	0	0	0	0	0	0	0

Register Description

The HPI Breakpoint register is a special on-chip memory location, which the external processor can access using normal HPI memory read/write cycles. This register is read-only by the CPU but is read/write by the HPI port. The contents of this register have the same effect as the Breakpoint register [0xC014]. This special Breakpoint register is used by software debuggers which interface through the HPI port instead of the serial port.

When the program counter matches the Breakpoint Address, the INT127 interrupt triggers. To clear this interrupt, a zero value must be written to this register.

Address (Bits [15:0])

The Address field is a 16-bit field containing the breakpoint address.

Interrupt Routing Register [0x0142] [R]

Figure 57. Interrupt Routing Register

Bit #	15	14	13	12	11	10	9	8
Field	VBUS to HPI Enable	ID to HPI Enable	SOF/EOP2 to HPI Enable	SOF/EOP2 to CPU Enable	SOF/EOP1 to HPI Enable	SOF/EOP1 to CPU Enable	Reset2 to HPI Enable	HPI Swap 1 Enable
Read/Write	R	R	R	R	R	R	R	R
Default	0	0	0	1	0	1	0	0

Bit #	7	6	5	4	3	2	1	0
Field	Resume2 to HPI Enable	Resume1 to HPI Enable	Reserved		Done2 to HPI Enable	Done1 to HPI Enable	Reset1 to HPI Enable	HPI Swap 0 Enable
Read/Write	-	-	-	-	-	-	-	-
Default	0	0	0	0	0	0	0	0

HPI Registers

There are five registers dedicated to HPI operation. In addition, there is an HPI status port which can be address over HPI. Each of these registers is covered in this section and are summarized in Table 32.

Table 32. HPI Registers

Register Name	Address	R/W
HPI Breakpoint Register	0x0140	R
Interrupt Routing Register	0x0142	R
SIE1msg Register	0x0144	W
SIE2msg Register	0x0148	W
HPI Mailbox Register	0xC0C6	R/W

Register Description

The Interrupt Routing register allows the HPI port to take over some or all of the SIE interrupts that usually go to the on-chip CPU. This register is read-only by the CPU but is read/write by the HPI port. By setting the appropriate bit to '1', the SIE interrupt is routed to the HPI port to become the HPI_INTR signal and also readable in the HPI Status register. The bits in this register select where the interrupts are routed. The individual interrupt enable is handled in the SIE interrupt enable register.

VBUS to HPI Enable (Bit 15)

The VBUS to HPI Enable bit routes the OTG VBUS interrupt to the HPI port instead of the on-chip CPU.

1: Route signal to HPI port

0: Do not route signal to HPI port

ID to HPI Enable (Bit 14)

The ID to HPI Enable bit routes the OTG ID interrupt to the HPI port instead of the on-chip CPU.

1: Route signal to HPI port

0: Do not route signal to HPI port

SOF/EOP2 to HPI Enable (Bit 13)

The SOF/EOP2 to HPI Enable bit routes the SOF/EOP2 interrupt to the HPI port.

1: Route signal to HPI port

0: Do not route signal to HPI port

SOF/EOP2 to CPU Enable (Bit 12)

The SOF/EOP2 to CPU Enable bit routes the SOF/EOP2 interrupt to the on-chip CPU. Since the SOF/EOP2 interrupt can be routed to both the on-chip CPU and the HPI port the firmware must ensure only one of the two (CPU, HPI) resets the interrupt.

1: Route signal to CPU

0: Do not route signal to CPU

SOF/EOP1 to HPI Enable (Bit 11)

The SOF/EOP1 to HPI Enable bit routes the SOF/EOP1 interrupt to the HPI port.

1: Route signal to HPI port

0: Do not route signal to HPI port

SOF/EOP1 to CPU Enable (Bit 10)

The SOF/EOP1 to CPU Enable bit routes the SOF/EOP1 interrupt to the on-chip CPU. Since the SOF/EOP1 interrupt can be routed to both the on-chip CPU and the HPI port the firmware must ensure only one of the two (CPU, HPI) resets the interrupt.

1: Route signal to CPU

0: Do not route signal to CPU

Reset2 to HPI Enable (Bit 9)

The Reset2 to HPI Enable bit routes the USB Reset interrupt that occurs on Device 2 to the HPI port instead of the on-chip CPU.

1: Route signal to HPI port

0: Do not route signal to HPI port

HPI Swap 1 Enable (Bit 8)

Both HPI Swap bits (bits 8 and 0) must be set to identical values. When set to '00', the most significant data byte goes to HPI_D[15:8] and the least significant byte goes to HPI_D[7:0]. This is the default setting. By setting to '11', the most significant data byte goes to HPI_D[7:0] and the least significant byte goes to HPI_D[15:8].

Resume2 to HPI Enable (Bit 7)

The Resume2 to HPI Enable bit routes the USB Resume interrupt that occurs on Host 2 to the HPI port instead of the on-chip CPU.

1: Route signal to HPI port

0: Do not route signal to HPI port

Resume1 to HPI Enable (Bit 6)

The Resume1 to HPI Enable bit routes the USB Resume interrupt that occurs on Host 1 to the HPI port instead of the on-chip CPU.

1: Route signal to HPI port

0: Do not route signal to HPI port

Done2 to HPI Enable (Bit 3)

The Done2 to HPI Enable bit routes the Done interrupt for Host/Device 2 to the HPI port instead of the on-chip CPU.

1: Route signal to HPI port

0: Do not route signal to HPI port

Done1 to HPI Enable (Bit 2)

The Done1 to HPI Enable bit routes the Done interrupt for Host/Device 1 to the HPI port instead of the on-chip CPU.

1: Route signal to HPI port

0: Do not route signal to HPI port

Reset1 to HPI Enable (Bit 1)

The Reset1 to HPI Enable bit routes the USB Reset interrupt that occurs on Device 1 to the HPI port instead of the on-chip CPU.

1: Route signal to HPI port

0: Do not route signal to HPI port

HPI Swap 0 Enable (Bit 0)

Both HPI Swap bits (bits 8 and 0) must be set to identical values. When set to '00', the most significant data byte goes to HPI_D[15:8] and the least significant byte goes to HPI_D[7:0]. This is the default setting. By setting to '11', the most significant data byte goes to HPI_D[7:0] and the least significant byte goes to HPI_D[15:8].

SIEXmsg Register [W] ^[10]

- SIE1msg Register 0x0144
- SIE2msg Register 0x0148

Figure 58. SIEXmsg Register

Bit #	15	14	13	12	11	10	9	8
Field	Data...							
Read/Write	W	W	W	W	W	W	W	W
Default	X	X	X	X	X	X	X	X

Bit #	7	6	5	4	3	2	1	0
Field	...Data							
Read/Write	W	W	W	W	W	W	W	W
Default	X	X	X	X	X	X	X	X

Register Description

The SIEXmsg register allows an interrupt to be generated on the HPI port. Any write to this register causes the SIEXmsg flag in the HPI Status Port to go high and also causes an interrupt on the HPI_INTR pin. The SIEXmsg flag is automatically cleared when the HPI port reads from this register.

Data (Bits [15:0])

The Data field[15:0] simply must have any value written to it to cause SIEXmsg flag in the HPI Status Port to go high.

HPI Mailbox Register [0xC0C6] [R/W]

Figure 59. HPI Mailbox Register

Bit #	15	14	13	12	11	10	9	8
Field	Message...							
Read/Write	R/W	R/W	R/W	R/W	R/W	R/W	R/W	R/W
Default	0	0	0	0	0	0	0	0

Bit #	7	6	5	4	3	2	1	0
Field	...Message							
Read/Write	R/W	R/W	R/W	R/W	R/W	R/W	R/W	R/W
Default	0	0	0	0	0	0	0	0

Register Description

The HPI Mailbox register provides a common mailbox between the CY7C67200 and the external host processor.

If enabled, the HPI Mailbox RX Full interrupt triggers when the external host processor writes to this register. When the CY7C67200 reads this register the HPI Mailbox RX Full interrupt automatically gets cleared.

If enabled, the HPI Mailbox TX Empty interrupt triggers when the external host processor reads from this register. The HPI Mailbox TX Empty interrupt is automatically cleared when the CY7C67200 writes to this register.

In addition, when the CY7C67200 writes to this register, the HPI_INTR signal on the HPI port asserts signaling the external processor that there is data in the mailbox to read. The HPI_INTR signal deasserts when the external host processor reads from this register.

Message (Bits [15:0])

The Message field contains the message that the host processor wrote to the HPI Mailbox register.

Note

10. **Errata:** The SIE1msg and SIE2msg Registers [0x0144 and 0x0148] are not initialized at power up. For more information, see the [Errata on page 84](#).

HPI Status Port [HPI: R]
Figure 60. HPI Status Port

Bit #	15	14	13	12	11	10	9	8
Field	VBUS Flag	ID Flag	Reserved	SOF/EOP2 Flag	Reserved	SOF/EOP1 Flag	Reset2 Flag	Mailbox In Flag
Read/Write	R	R	-	R	-	R	R	R
Default	X	X	X	X	X	X	X	X

Bit #	7	6	5	4	3	2	1	0
Field	Resume2 Flag	Resume1 Flag	SIE2msg	SIE1msg	Done2 Flag	Done1 Flag	Reset1 Flag	Mailbox Out Flag
Read/Write	R	R	R	R	R	R	R	R
Default	X	X	X	X	X	X	X	X

Register Description

The HPI Status Port provides the external host processor with the MailBox status bits plus several SIE status bits. This register is not accessible from the on-chip CPU. The additional SIE status bits are provided to aid external device driver firmware development, and are not recommended for applications that do not have an intimate relationship with the on-chip BIOS.

Reading from the HPI Status Port does not result in a CPU HPI interface memory access cycle. The external host may continuously poll this register without degrading the CPU or DMA performance.

VBUS Flag (Bit 15)

The VBUS Flag bit is a read-only bit that indicates whether OTG VBus is greater than 4.4 V. After turning on VBUS, firmware should wait at least 10 μ s before this reading this bit.

- 1: OTG VBus is greater than 4.4 V
- 0: OTG VBus is less than 4.4 V

ID Flag (Bit 14)

The ID Flag bit is a read-only bit that indicates the state of the OTG ID pin.

SOF/EOP2 Flag (Bit 12)

The SOF/EOP2 Flag bit is a read-only bit that indicates if a SOF/EOP interrupt occurs on either Host/Device 2.

- 1: Interrupt triggered
- 0: Interrupt did not trigger

SOF/EOP1 Flag (Bit 10)

The SOF/EOP1 Flag bit is a read-only bit that indicates if a SOF/EOP interrupt occurs on either Host/Device 1.

- 1: Interrupt triggered
- 0: Interrupt did not trigger

Reset2 Flag (Bit 9)

The Reset2 Flag bit is a read-only bit that indicates if a USB Reset interrupt occurs on either Host/Device 2.

- 1: Interrupt triggered

0: Interrupt did not trigger

Mailbox In Flag (Bit 8)

The Mailbox In Flag bit is a read-only bit that indicates if a message is ready in the incoming mailbox. This interrupt clears when on-chip CPU reads from the HPI Mailbox register.

- 1: Interrupt triggered
- 0: Interrupt did not trigger

Resume2 Flag (Bit 7)

The Resume2 Flag bit is a read-only bit that indicates if a USB resume interrupt occurs on either Host/Device 2.

- 1: Interrupt triggered
- 0: Interrupt did not trigger

Resume1 Flag (Bit 6)

The Resume1 Flag bit is a read-only bit that indicates if a USB resume interrupt occurs on either Host/Device 1.

- 1: Interrupt triggered
- 0: Interrupt did not trigger

SIE2msg (Bit 5)

The SIE2msg Flag bit is a read-only bit that indicates if the CY7C67200 CPU has written to the SIE2msg register. This bit is cleared on an HPI read.

- 1: The SIE2msg register has been written by the CY7C67200 CPU
- 0: The SIE2msg register has not been written by the CY7C67200 CPU

SIE1msg (Bit 4)

The SIE1msg Flag bit is a read-only bit that indicates if the CY7C67200 CPU has written to the SIE1msg register. This bit is cleared on an HPI read.

- 1: The SIE1msg register has been written by the CY7C67200 CPU
- 0: The SIE1msg register has not been written by the CY7C67200 CPU

Done2 Flag (Bit 3)

In host mode the Done2 Flag bit is a read-only bit that indicates if a host packet done interrupt occurs on Host 2. In device mode this read only bit indicates if any of the endpoint interrupts occurs on Device 2. Firmware needs to determine which endpoint interrupt occurred.

1: Interrupt triggered

0: Interrupt did not trigger

Done1 Flag (Bit 2)

In host mode the Done 1 Flag bit is a read-only bit that indicates if a host packet done interrupt occurs on Host 1. In device mode this read-only bit indicates if any of the endpoint interrupts occurs on Device 1. Firmware needs to determine which endpoint interrupt occurred.

1: Interrupt triggered

0: Interrupt did not trigger

Reset1 Flag (Bit 1)

The Reset1 Flag bit is a read-only bit that indicates if a USB Reset interrupt occurs on either Host/Device 1.

1: Interrupt triggered

0: Interrupt did not trigger

Mailbox Out Flag (Bit 0)

The Mailbox Out Flag bit is a read-only bit that indicates if a message is ready in the outgoing mailbox. This interrupt clears when the external host reads from the HPI Mailbox register.

1: Interrupt triggered

0: Interrupt did not trigger

SPI Registers

There are 12 registers dedicated to SPI operation. Each register is covered in this section and summarized in [Table 33](#).

Table 33. SPI Registers

Register Name	Address	R/W
SPI Configuration Register	0xC0C8	R/W
SPI Control Register	0xC0CA	R/W
SPI Interrupt Enable Register	0xC0CC	R/W
SPI Status Register	0xC0CE	R
SPI Interrupt Clear Register	0xC0D0	W
SPI CRC Control Register	0xC0D2	R/W
SPI CRC Value	0xC0D4	R/W
SPI Data Register	0xC0D6	R/W
SPI Transmit Address Register	0xC0D8	R/W
SPI Transmit Count Register	0xC0DA	R/W
SPI Receive Address Register	0xC0DC	R/W
SPI Receive Count Register	0xC0DE	R/W

SPI Configuration Register [0xC0C8] [R/W]

Figure 61. SPI Configuration Register

Bit #	15	14	13	12	11	10	9	8
Field	3Wire Enable	Phase Select	SCK Polarity Select	Scale Select				Reserved
Read/Write	R/W	R/W	R/W	R/W	R/W	R/W	R/W	-
Default	1	0	0	0	0	0	0	0

Bit #	7	6	5	4	3	2	1	0
Field	Master Active Enable	Master Enable	SS Enable	SS Delay Select				
Read/Write	R	R/W	R/W	R/W	R/W	R/W	R/W	R/W
Default	0	0	0	1	1	1	1	1

Register Description

The SPI Configuration register controls the SPI port. Fields apply to both master and slave mode unless otherwise noted.

3Wire Enable (Bit 15)

The 3Wire Enable bit indicates if the MISO and MOSI data lines are tied together allowing only half duplex operation.

1: MISO and MOSI data lines are tied together

0: Normal MISO and MOSI Full Duplex operation (not tied together)

Phase Select (Bit 14)

The Phase Select bit selects advanced or delayed SCK phase. This field only applies to master mode.

1: Advanced SCK phase

0: Delayed SCK phase

SCK Polarity Select (Bit 13)

This SCK Polarity Select bit selects the polarity of SCK.

1: Positive SCK polarity

0: Negative SCK polarity

Scale Select (Bits [12:9])

The Scale Select field provides control over the SCK frequency, based on 48 MHz. See [Table 34](#) for a definition of this field. This field only applies to master mode.

Table 34. Scale Select Field Definition for SCK Frequency

Scale Select [12:9]	SCK Frequency
0000	12 MHz
0001	8 MHz
0010	6 MHz
0011	4 MHz
0100	3 MHz
0101	2 MHz
0110	1.5 MHz
0111	1 MHz
1000	750 KHz
1001	500 KHz
1010	375 KHz
1011	250 KHz
1100	375 KHz
1101	250 KHz
1110	375 KHz
1111	250 KHz

Master Active Enable (Bit 7)

The Master Active Enable bit is a read-only bit that indicates if the master state machine is active or idle. This field only applies to master mode.

1: Master state machine is active

0: Master state machine is idle

Master Enable (Bit 6)

The Master Enable bit sets the SPI interface to master or slave. This bit is only writable when the Master Active Enable bit reads '0', otherwise value will not change.

1: Master SPI interface

0: Slave SPI interface

SS Enable (Bit 5)

The SS Enable bit enables or disables the master SS output.

1: Enable master SS output

0: Disable master SS output (three-state master SS output, for single SS line in slave mode)

SS Delay Select (Bits [4:0])

When the SS Delay Select field is set to '00000' this indicates manual mode. In manual mode SS is controlled by the SS Manual bit of the SPI Control register. When the SS Delay Select field is set between '00001' to '11111', this value indicates the count in half bit times of auto transfer delay for: SS LOW to SCK active, SCK inactive to SS HIGH, SS HIGH time. This field only applies to master mode.

SPI Control Register [0xC0CA] [R/W]

Figure 62. SPI Control Register

Bit #	15	14	13	12	11	10	9	8
Field	SCK Strobe	FIFO Init	Byte Mode	Full Duplex	SS Manual	Read Enable	Transmit Ready	Receive Data Ready
Read/Write	W	W	R/W	R/W	R/w	R/W	R	R
Default	0	0	0	0	0	0	0	1

Bit #	7	6	5	4	3	2	1	0
Field	Transmit Empty	Receive Full	Transmit Bit Length			Receive Bit Length		
Read/Write	R	R	R/W	R/W	R/W	R/W	R/w	R/W
Default	1	0	0	0	0	0	0	0

Register Description

The SPI Control register controls the SPI port. Fields apply to both master and slave mode unless otherwise noted.

SCK Strobe (Bit 15)

The SCK Strobe bit starts the SCK strobe at the selected frequency and polarity (set in the SPI Configuration register), but not phase. This bit feature can only be enabled when in master mode and must be during a period of inactivity. This bit is self-clearing.

1: SCK Strobe Enable

0: No Function

FIFO Init (Bit 14)

The FIFO Init bit initializes the FIFO and clear the FIFO Error Status bit. This bit is self-clearing.

1: FIFO Init Enable

0: No Function

Byte Mode (Bit 13)

The Byte Mode bit selects between PIO (byte mode) and DMA (block mode) operation.

1: Set PIO (byte mode) operation

0: Set DMA (block mode) operation

Full Duplex (Bit 12)

The Full Duplex bit selects between full-duplex and half-duplex operation.

1: Enable full duplex. Full duplex is not allowed and will not set if the 3Wire Enable bit of the SPI Configuration register is set to '1'

0: Enable half-duplex operation

SS Manual (Bit 11)

The SS Manual bit activates or deactivates SS if the SS Delay Select field of the SPI Control register is all zeros and is configured as master interface. This field only applies to master mode.

1: Activate SS, master drives SS line asserted LOW

0: Deactivate SS, master drives SS line deasserted HIGH

Read Enable (Bit 10)

The Read Enable bit initiates a read phase for a master mode transfer or set the slave to receive (in slave mode).

1: Initiates a read phase for a master transfer or sets a slave to receive. In master mode this bit is sticky and remains set until the read transfer begins.

0: Initiates the write phase for slave operation

Transmit Ready (Bit 9)

The Transmit Ready bit is a read-only bit that indicates if the transmit port is ready to empty and ready to be written.

1: Ready for data to be written to the port. The transmit FIFO is not full.

0: Not ready for data to be written to the port

Receive Data Ready (Bit 8)

The Receive Data Ready bit is a read-only bit that indicates if the receive port has data ready.

1: Receive port has data ready to read

0: Receive port does not have data ready

Transmit Empty (Bit 7)

The Transmit Empty bit is a read-only bit that indicates if the transmit FIFO is empty.

1: Transmit FIFO is empty

0: Transmit FIFO is not empty

Receive Full (Bit 6)

The Receive Full bit is a read-only bit that indicates if the receive FIFO is full.

1: Receive FIFO is full

0: Receive FIFO is not full

Transmit Bit Length (Bits [5:3])

The Transmit Bit Length field controls whether a full byte or partial byte is to be transmitted. If Transmit Bit Length is '000', a full byte is transmitted. If Transmit Bit Length is '001' to '111', the value indicates the number of bits that will be transmitted.

Receive Bit Length (Bits [2:0])

The Receive Bit Length field controls whether a full byte or partial byte will be received. If Receive Bit Length is '000' then a full byte will be received. If Receive Bit Length is '001' to '111', then the value indicates the number of bits that will be received.

SPI Interrupt Enable Register [0xC0CC] [R/W]

Figure 63. SPI Interrupt Enable Register

Bit #	15	14	13	12	11	10	9	8
Field	Reserved...							
Read/Write	-	-	-	-	-	-	-	-
Default	0	0	0	0	0	0	0	0

Bit #	7	6	5	4	3	2	1	0
Field	...Reserved					Receive Interrupt Enable	Transmit Interrupt Enable	Transfer Interrupt Enable
Read/Write	-	-	-	-	-	R/W	R/W	R/W
Default	0	0	0	0	0	0	0	0

Register Description

The SPI Interrupt Enable register controls the SPI port.

Receive Interrupt Enable (Bit 2)

The Receive Interrupt Enable bit enables or disables the byte mode receive interrupt (RxIntVal).

- 1: Enable byte mode receive interrupt
- 0: Disable byte mode receive interrupt

Transmit Interrupt Enable (Bit 1)

The Transmit Interrupt Enable bit enables or disables the byte mode transmit interrupt (TxIntVal).

- 1: Enables byte mode transmit interrupt
- 0: Disables byte mode transmit interrupt

Transfer Interrupt Enable (Bit 0)

The Transfer Interrupt Enable bit enables or disables the block mode interrupt (XfrBlkIntVal).

- 1: Enables block mode interrupt
- 0: Disables block mode interrupt

Reserved

All reserved bits must be written as '0'.

SPI Status Register [0xC0CE] [R]

Figure 64. SPI Status Register

Bit #	15	14	13	12	11	10	9	8
Field	Reserved							
Read/Write	-	-	-	-	-	-	-	-
Default	0	0	0	0	0	0	0	0

Bit #	7	6	5	4	3	2	1	0	
Field	FIFO Error Flag	Reserved					Receive Interrupt Flag	Transmit Interrupt Flag	Transfer Interrupt Flag
Read/Write	R	-	-	-	-	R	R	R	
Default	0	0	0	0	0	0	0	0	

Register Description

The SPI Status register is a read only register that provides status for the SPI port.

FIFO Error Flag (Bit 7)

The FIFO Error Flag bit is a read only bit that indicates if a FIFO error occurred. When this bit is set to '1' and the Transmit Empty bit of the SPI Control register is set to '1', then a Tx FIFO underflow has occurred. Similarly, when set with the Receive Full bit of the SPI Control register, a Rx FIFO overflow has occurred. This bit automatically clear when the SPI FIFO Init Enable bit of the SPI Control register is set.

- 1: Indicates FIFO error
- 0: Indicates no FIFO error

Receive Interrupt Flag (Bit 2)

The Receive Interrupt Flag is a read only bit that indicates if a byte mode receive interrupt has triggered.

- 1: Indicates a byte mode receive interrupt has triggered
- 0: Indicates a byte mode receive interrupt has not triggered

Transmit Interrupt Flag (Bit 1)

The Transmit Interrupt Flag is a read only bit that indicates a byte mode transmit interrupt has triggered.

- 1: Indicates a byte mode transmit interrupt has triggered
- 0: Indicates a byte mode transmit interrupt has not triggered

Transfer Interrupt Flag (Bit 0)

The Transfer Interrupt Flag is a read only bit that indicates a block mode interrupt has triggered.

- 1: Indicates a block mode interrupt has triggered
- 0: Indicates a block mode interrupt has not triggered

SPI Interrupt Clear Register [0xC0D0] [W]

Figure 65. SPI Interrupt Clear Register

Bit #	15	14	13	12	11	10	9	8
Field	Reserved							
Read/Write	-	-	-	-	-	-	-	-
Default	0	0	0	0	0	0	0	0

Bit #	7	6	5	4	3	2	1	0
Field	Reserved						Transmit Interrupt Clear	Transfer Interrupt Clear
Read/Write	-	-	-	-	-	-	W	W
Default	0	0	0	0	0	0	0	0

Register Description

The SPI Interrupt Clear register is a write-only register that allows the SPI Transmit and SPI Transfer Interrupts to be cleared.

Transmit Interrupt Clear (Bit 1)

The Transmit Interrupt Clear bit is a write-only bit that clears the byte mode transmit interrupt. This bit is self-clearing.

- 1: Clear the byte mode transmit interrupt
- 0: No function

Transfer Interrupt Clear (Bit 0)

The Transfer Interrupt Clear bit is a write-only bit that will clear the block mode interrupt. This bit is self-clearing.

- 1: Clear the block mode interrupt
- 0: No function

Reserved

All reserved bits must be written as '0'.

SPI CRC Control Register [0xC0D2] [R/W]

Figure 66. SPI CRC Control Register

Bit #	15	14	13	12	11	10	9	8
Field	CRC Mode		CRC Enable	CRC Clear	Receive CRC	One in CRC	Zero in CRC	Reserved...
Read/Write	R/W	R/W	R/W	R/W	R/W	R	R	-
Default	0	0	0	0	0	0	0	0

Bit #	7	6	5	4	3	2	1	0
Field	...Reserved							
Read/Write	-	-	-	-	-	-	-	-
Default	0	0	0	0	0	0	0	0

Register Description

The SPI CRC Control register provides control over the CRC source and polynomial value.

CRC Mode (Bits [15:14])

The CRCMode field selects the CRC polynomial as defined in Table 35.

Table 35. CRC Mode Definition

CRCMode [9:8]	CRC Polynomial
00	MMC 16-bit: $X^{16} + X^{12} + X^5 + 1$ (CCITT Standard)
01	CRC7 7-bit: $X^7 + X^3 + 1$
10	MST 16-bit: $X^{16} + X^{15} + X^2 + 1$
11	Reserved, 16-bit polynomial 1.

CRC Enable (Bit 13)

The CRC Enable bit enables or disables the CRC operation.

- 1: Enables CRC operation
- 0: Disables CRC operation

CRC Clear (Bit 12)

The CRC Clear bit will clear the CRC with a load of all ones. This bit is self clearing and always reads '0'.

SPI CRC Value Register [0xC0D4] [R/W]

Figure 67. SPI CRC Value Register

Bit #	15	14	13	12	11	10	9	8
Field	CRC...							
Read/Write	R/W	R/W	R/W	R/W	R/W	R/W	R/W	R/W
Default	1	1	1	1	1	1	1	1

Bit #	7	6	5	4	3	2	1	0
Field	...CRC							
Read/Write	R/W	R/W	R/W	R/W	R/W	R/W	R/W	R/W
Default	1	1	1	1	1	1	1	1

Register Description

The SPI CRC Value register contains the CRC value.

CRC (Bits [15:0])

The CRC field contains the SPI CRC. In CRC Mode CRC7, the CRC value will be a seven bit value [6:0]. Therefore bits [15:7] are invalid in CRC7 mode.

1: Clear CRC with all ones

0: No Function

Receive CRC (Bit 11)

The Receive CRC bit determines whether the receive bit stream or the transmit bit stream is used for the CRC data input in full duplex mode. This bit is a don't care in half-duplex mode.

- 1: Assigns the receive bit stream
- 0: Assigns the transmit bit stream

One in CRC (Bit 10)

The One in CRC bit is a read-only bit that indicates if the CRC value is all zeros or not.

- 1: CRC value is not all zeros
- 0: CRC value is all zeros

Zero in CRC (Bit 9)

The Zero in CRC bit is a read-only bit that indicates if the CRC value is all ones or not.

- 1: CRC value is not all ones
- 0: CRC value is all ones

Reserved

All reserved bits must be written as '0'.

SPI Data Register [0xC0D6] [R/W]

Figure 68. SPI Data Register

Bit #	15	14	13	12	11	10	9	8
Field	Reserved							
Read/Write	-	-	-	-	-	-	-	-
Default	X	X	X	X	X	X	X	X
Bit #	7	6	5	4	3	2	1	0
Field	Data							
Read/Write	R/W	R/W	R/W	R/W	R/W	R/W	R/W	R/W
Default	X	X	X	X	X	X	X	X

Register Description

The SPI Data register contains data received on the SPI port when read. Reading it empties the eight byte receive FIFO in PIO byte mode. This receive data is valid when the receive bit of the SPI Interrupt Value is set to '1' (RxIntVal triggers) or the Receive Data Ready bit of the SPI Control register is set to '1'. Writing to this register in PIO byte mode will initiate a transfer of data, the number of bits defined by Transmit Bit Length field in the SPI Control register.

Data (Bits [7:0])

The Data field contains data received or to be transmitted on the SPI port.

Reserved

All reserved bits must be written as '0'.

SPI Transmit Address Register [0xC0D8] [R/W]

Figure 69. SPI Transmit Address Register

Bit #	15	14	13	12	11	10	9	8
Field	Address...							
Read/Write	R/W	R/W	R/W	R/W	R/W	R/W	R/W	R/W
Default	0	0	0	0	0	0	0	0
Bit #	7	6	5	4	3	2	1	0
Field	...Address							
Read/Write	R/W	R/W	R/W	R/W	R/W	R/W	R/W	R/W
Default	0	0	0	0	0	0	0	0

Register Description

The SPI Transmit Address register is used as the base address for the SPI transmit DMA.

Address (Bits [15:0])

The Address field sets the base address for the SPI transmit DMA.

SPI Transmit Count Register [0xC0DA] [R/W]

Figure 70. SPI Transmit Count Register

Bit #	15	14	13	12	11	10	9	8	
Field	Reserved					Count...			
Read/Write	-	-	-	-	-	R/W	R/W	R/W	
Default	0	0	0	0	0	0	0	0	

Bit #	7	6	5	4	3	2	1	0
Field	...Count							
Read/Write	R/W	R/W	R/W	R/W	R/W	R/W	R/W	R/W
Default	0	0	0	0	0	0	0	0

Register Description

The SPI Transmit Count register designates the block byte length for the SPI transmit DMA transfer.

Count (Bits [10:0])

The Count field sets the count for the SPI transmit DMA transfer.

Reserved

All reserved bits must be written as '0'.

SPI Receive Address Register [0xC0DC] [R/W]

Figure 71. SPI Receive Address Register

Bit #	15	14	13	12	11	10	9	8
Field	Address...							
Read/Write	R/W	R/W	R/W	R/W	R/W	R/W	R/W	R/W
Default	0	0	0	0	0	0	0	0

Bit #	7	6	5	4	3	2	1	0
Field	...Address							
Read/Write	R/W	R/W	R/W	R/W	R/W	R/W	R/W	R/W
Default	0	0	0	0	0	0	0	0

Register Description

The SPI Receive Address register is issued as the base address for the SPI Receive DMA.

Address (Bits [15:0])

The Address field sets the base address for the SPI receive DMA.

SPI Receive Count Register [0xC0DE] [R/W]

Figure 72. SPI Receive Count Register

Bit #	15	14	13	12	11	10	9	8	
Field	Reserved					Count...			
Read/Write	-	-	-	-	-	R/W	R/W	R/W	
Default	0	0	0	0	0	0	0	0	

Bit #	7	6	5	4	3	2	1	0
Field	...Count							
Read/Write	R/W	R/W	R/W	R/W	R/W	R/W	R/W	R/W
Default	0	0	0	0	0	0	0	0

Register Description

The SPI Receive Count register designates the block byte length for the SPI receive DMA transfer.

Count (Bits [10:0])

The Count field sets the count for the SPI receive DMA transfer.

Reserved

All reserved bits must be written as '0'.

UART Registers

There are three registers dedicated to UART operation. Each of these registers is covered in this section and summarized in [Table 36](#).

Table 36. UART Registers

Register Name	Address	R/W
UART Control Register	0xC0E0	R/W
UART Status Register	0xC0E2	R
UART Data Register	0xC0E4	R/W

UART Control Register [0xC0E0] [R/W]

Figure 73. UART Control Register

Bit #	15	14	13	12	11	10	9	8
Field	Reserved...							
Read/Write	-	-	-	-	-	-	-	-
Default	0	0	0	0	0	0	0	0

Bit #	7	6	5	4	3	2	1	0
Field	...Reserved			Scale Select	Baud Select			UART Enable
Read/Write	-	-	-	R/W	R/W	R/W	R/W	R/W
Default	0	0	0	0	0	1	1	1

Register Description

The UART Control register enables or disables the UART allowing GPIO7 (UART_TXD) and GPIO6 (UART_RXD) to be freed up for general use. This register must also be written to set the baud rate, which is based on a 48-MHz clock.

Scale Select (Bit 4)

The Scale Select bit acts as a prescaler that will divide the baud rate by eight.

1: Enable prescaler

0: Disable prescaler

Baud Select (Bits [3:1])

Refer to [Table 37](#) for a definition of this field.

Table 37. UART Baud Select Definition

Baud Select [3:1]	Baud Rate w/DIV8 = 0	Baud Rate w/DIV8 = 1
000	115.2K baud	14.4K baud
001	57.6K baud	7.2K baud
010	38.4K baud	4.8K baud
011	28.8K baud	3.6K baud
100	19.2K baud	2.4K baud
101	14.4K baud	1.8K baud
110	9.6K baud	1.2K baud
111	7.2K baud	0.9K baud

UART Enable (Bit 0)

The UART Enable bit enables or disables the UART.

1: Enable UART

0: Disable UART. This allows GPIO6 and GPIO7 to be used for general use

Reserved

All reserved bits must be written as '0'.

UART Status Register [0xC0E2] [R]

Figure 74. UART Status Register

Bit #	15	14	13	12	11	10	9	8
Field	Reserved...							
Read/Write	-	-	-	-	-	-	-	-
Default	0	0	0	0	0	0	0	0

Bit #	7	6	5	4	3	2	1	0
Field	...Reserved						Receive Full	Transmit Full
Read/Write	-	-	-	-	-	-	R	R
Default	0	0	0	0	0	0	0	0

Register Description

The UART Status register is a read-only register that indicates the status of the UART buffer.

Receive Full (Bit 1)

The Receive Full bit indicates whether the receive buffer is full. It can be programmed to interrupt the CPU as interrupt #5 when the buffer is full. This can be done through the UART bit of the Interrupt Enable register (0xC00E). This bit will automatically be cleared when data is read from the UART Data register.

- 1: Receive buffer full
- 0: Receive buffer empty

Transmit Full (Bit 0)

The Transmit Full bit indicates whether the transmit buffer is full. It can be programmed to interrupt the CPU as interrupt #4 when the buffer is empty. This can be done through the UART bit of the Interrupt Enable register (0xC00E). This bit will automatically be set to '1' after data is written by EZ-Host to the UART Data register (to be transmitted). This bit will automatically be cleared to '0' after the data is transmitted.

- 1: Transmit buffer full (transmit busy)
- 0: Transmit buffer is empty and ready for a new byte of data

UART Data Register [0xC0E4] [R/W]

Figure 75. UART Data Register

Bit #	15	14	13	12	11	10	9	8
Field	Reserved							
Read/Write	-	-	-	-	-	-	-	-
Default	0	0	0	0	0	0	0	0

Bit #	7	6	5	4	3	2	1	0
Field	Data							
Read/Write	R/W	R/W	R/W	R/W	R/W	R/W	R/W	R/W
Default	0	0	0	0	0	0	0	0

Register Description

The UART Data register contains data to be transmitted or received from the UART port. Data written to this register will start a data transmission and also causes the UART Transmit Empty Flag of the UART Status register to set. When data received on the UART port is read from this register, the UART Receive Full Flag of the UART Status register will be cleared.

Data (Bits [7:0])

The Data field is where the UART data to be transmitted or received is located

Reserved

All reserved bits must be written as '0'.

Pin Diagram

The following describes the CY7C67200 48-pin FBGA.

Figure 76. EZ-OTG Pin Diagram

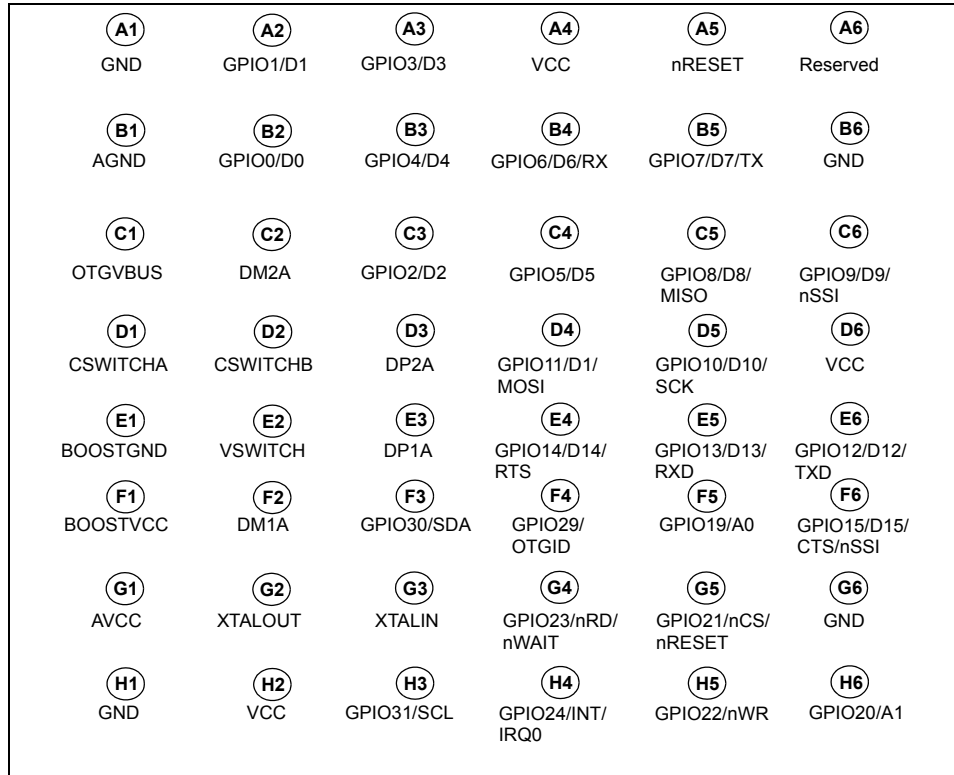

Pin Descriptions

Table 38. Pin Descriptions

Pin	Name	Type	Description
H3	GPIO31/SCK	IO	GPIO31: General Purpose IO SCK: I2C EEPROM SCK
F3	GPIO30/SDA	IO	GPIO30: General Purpose IO SDA: I2C EEPROM SDA
F4	GPIO29/OTGID	IO	GPIO29: General Purpose IO OTGID: Input for OTG ID pin. When used as OTGID, this pin must be tied high through an external pull-up resistor. Assuming V _{CC} = 3.0 V, a 10K to 40K resistor must be used.
H4	GPIO24/INT/IRQ0 ^[11]	IO	GPIO24: General Purpose IO INT: HPI INT IRQ0: Interrupt Request 0. See Register 0xC006. This pin is also one of two possible GPIO wakeup sources.
G4	GPIO23/nRD	IO	GPIO23: General Purpose IO nRD: HPI nRD

Note

11. **Errata:** Part does not service USB ISRs when GPIO24 pin (also labeled as HPI_INT and IORDY) is low and any IDE register is read. For more information, see the [Errata on page 84](#).

Table 38. Pin Descriptions (continued)

Pin	Name	Type	Description
H5	GPIO22/nWR	IO	GPIO22: General Purpose IO nWR: HPI nWR
G5	GPIO21/nCS	IO	GPIO21: General Purpose IO nCS: HPI nCS
H6	GPIO20/A1	IO	GPIO20: General Purpose IO A1: HPI A1
F5	GPIO19/A0	IO	GPIO19: General Purpose IO A0: HPI A0
F6	GPIO15/D15/CTS/ nSSI	IO	GPIO15: General Purpose IO D15: D15 for HPI CTS: HSS CTS nSSI: SPI nSSI
E4	GPIO14/D14/RTS	IO	GPIO14: General Purpose IO D14: D14 for HPI RTS: HSS RTS
E5	GPIO13/D13/RXD	IO	GPIO13: General Purpose IO D13: D13 for HPI RXD: HSS RXD (Data is received on this pin)
E6	GPIO12/D12/TXD	IO	GPIO12: General Purpose IO D12: D12 for HPI TXD: HSS TXD (Data is transmitted from this pin)
D4	GPIO11/D11/MOSI	IO	GPIO11: General Purpose IO D11: D11 for HPI MOSI: SPI MOSI
D5	GPIO10/D10/SCK	IO	GPIO10: General Purpose IO D10: D10 for HPI SCK: SPI SCK
C6	GPIO9/D9/nSSI	IO	GPIO9: General Purpose IO D9: D9 for HPI nSSI: SPI nSSI
C5	GPIO8/D8/MISO	IO	GPIO8: General Purpose IO D8: D8 for HPI MISO: SPI MISO
B5	GPIO7/D7/TX	IO	GPIO7: General Purpose IO D7: D7 for HPI TX: UART TX (Data is transmitted from this pin)
B4	GPIO6/D6/RX	IO	GPIO6: General Purpose IO D6: D6 for HPI RX: UART RX (Data is received on this pin)
C4	GPIO5/D5	IO	GPIO5: General Purpose IO D5: D5 for HPI
B3	GPIO4/D4	IO	GPIO4: General Purpose IO D4: D4 for HPI
A3	GPIO3/D3	IO	GPIO3: General Purpose IO D3: D3 for HPI
C3	GPIO2/D2	IO	GPIO2: General Purpose IO D2: D2 for HPI
A2	GPIO1/D1	IO	GPIO1: General Purpose IO D1: D1 for HPI
B2	GPIO0/D0	IO	GPIO0: General Purpose IO D0: D0 for HPI
F2	DM1A	IO	USB Port 1A D–
E3	DP1A	IO	USB Port 1A D+
C2	DM2A	IO	USB Port 2A D–

Table 38. Pin Descriptions (continued)

Pin	Name	Type	Description
D3	DP2A	IO	USB Port 2A D+
G3	XTALIN	Input	Crystal Input or Direct Clock Input
G2	XTALOUT	Output	Crystal output. Leave floating if direct clock source is used.
A5	nRESET	Input	Reset
A6	Reserved	–	Tie to Gnd for normal operation.
F1	BOOSTV _{CC}	Power	Booster Power Input: 2.7 V to 3.6 V
E2	VSWITCH	Analog Output	Booster Switching Output
E1	BOOSTGND	Ground	Booster Ground
C1	OTGVBUS	Analog IO	USB OTG Vbus
D1	CSWITCHA	Analog	Charge Pump Capacitor
D2	CSWITCHB	Analog	Charge Pump Capacitor
G1	AV _{CC}	Power	USB Power
B1	AGND	Ground	USB Ground
H2, D6, A4	V _{CC}	Power	Main V _{CC}
G6, B6, A1, H1	GND	Ground	Main Ground

Absolute Maximum Ratings

This section lists the absolute maximum ratings. Stresses above those listed can cause permanent damage to the device.

Exposure to maximum rated conditions for extended periods can affect device operation and reliability.

- Storage Temperature –40°C to +125°C
- Ambient Temperature with Power Supplied.. –40°C to +85°C
- Supply Voltage to Ground Potential.....0.0 V to +3.6 V
- DC Input Voltage to Any General Purpose Input Pin 5.5 V
- DC Voltage Applied to XTALIN –0.5 V to V_{CC} + 0.5 V
- Static Discharge Voltage (per MIL-STD-883, Method 3015)> 2000 V

Max Output Current, per Input Output 4 mA

Crystal Requirements (XTALIN, XTALOUT)

Table 39. Crystal Requirements

Crystal Requirements, (XTALIN, XTALOUT)	Min	Typical	Max	Unit
Parallel Resonant Frequency		12		MHz
Frequency Stability	–500		+500	PPM
Load Capacitance	20		33	pF
Driver Level			500	μW
Start-up Time			5	ms
Mode of Vibration: Fundamental				

Operating Conditions

- T_A (Ambient Temperature Under Bias) –40°C to +85°C
- Supply Voltage (V_{CC}, AV_{CC}) +3.0 V to +3.6 V
- Supply Voltage (BoostV_{CC})^[12] +2.7 V to +3.6 V
- Ground Voltage..... 0 V
- F_{OSC} (Oscillator or Crystal Frequency).... 12 MHz ± 500 ppm
- Parallel Resonant

Note

12. The on-chip voltage booster circuit boosts BoostV_{CC} to provide a nominal 3.3 V V_{CC} supply.

DC Characteristics

Table 40. DC Characteristics^[13]

Parameter	Description	Conditions	Min.	Typ.	Max.	Unit
V _{CC} , AV _{CC}	Supply Voltage		3.0	3.3	3.6	V
BoosV _{CC}	Supply Voltage		2.7	–	3.6	V
V _{IH}	Input HIGH Voltage		2.0	–	5.5	V
V _{IL}	Input LOW Voltage		–	–	0.8	V
I _I	Input Leakage Current	0 < V _{IN} < V _{CC}	–10.0	–	+10.0	μA
V _{OH}	Output Voltage HIGH	I _{OUT} = 4 mA	2.4	–	–	V
V _{OL}	Output LOW Voltage	I _{OUT} = –4 mA	–	–	0.4	V
I _{OH}	Output Current HIGH		–	–	4	mA
I _{OL}	Output Current LOW		–	–	4	mA
C _{IN}	Input Pin Capacitance	Except D+/D–	–	–	10	pF
		D+/D–	–	–	15	pF
V _{HYS}	Hysteresis on nReset Pin		250	–	–	mV
I _{CC} ^[14, 15]	Supply Current	2 transceivers powered	–	80	100	mA
I _{CCB} ^[14, 15]	Supply Current with Booster Enabled	2 transceivers powered	–	135	180	mA
I _{SLEEP}	Sleep Current	USB Peripheral: includes 1.5K internal pull up	–	210	500	μA
		Without 1.5K internal pull up	–	5	30	μA
I _{SLEEPB}	Sleep Current with Booster Enabled	USB Peripheral: includes 1.5K internal pull up	–	210	500	μA
		Without 1.5K internal pull up	–	5	30	μA

Table 41. DC Characteristics: Charge Pump

Parameter	Description	Conditions	Min.	Typ.	Max.	Unit
V _{A_VBUS_OUT}	Regulated OTGVBUS Voltage	8 mA < I _{LOAD} < 10 mA	4.4	–	5.25	V
T _{A_VBUS_RISE}	V _{BUS} Rise Time	I _{LOAD} = 10 mA		–	100	ms
I _{A_VBUS_OUT}	Maximum Load Current		8	–	10	mA
C _{DRD_VBUS}	OUTVBUS Bypass Capacitance	4.4 V < V _{BUS} < 5.25 V	1.0	–	6.5	pF
V _{A_VBUS_LKG}	OTGVBUS Leakage Voltage	OTGVBUS not driven	–	–	200	mV
V _{DRD_DATA_LKG}	Dataline Leakage Voltage		–	–	342	mV
I _{CHARGE}	Charge Pump Current Draw	I _{LOAD} = 8 mA	–	20	20	mA
		I _{LOAD} = 0 mA	–	0	1	mA
I _{CHARGE B}	Charge Pump Current Draw with Booster Active	I _{LOAD} = 8 mA	–	30	45	mA
		I _{LOAD} = 0 mA	–	0	5	mA
I _{B_DSCHG_IN}	B-Device (SRP Capable) Discharge Current	0 V < V _{BUS} < 5.25 V	–	–	8	mA
V _{A_VBUS_VALID}	A-Device VBUS Valid		4.4	–	–	V

Notes

13. All tests were conducted with Charge pump off.

14. I_{CC} and I_{CCB} values are the same regardless of USB host or peripheral configuration.

15. There is no appreciable difference in I_{CC} and I_{CCB} values when only one transceiver is powered.

Table 41. DC Characteristics: Charge Pump (continued)

Parameter	Description	Conditions	Min.	Typ.	Max.	Unit
V _{A_SESS_VALID}	A-Device Session Valid		0.8	–	2.0	V
V _{B_SESS_VALID}	B-Device Session Valid		0.8	–	4.0	V
V _{A_SESS_END}	B-Device Session End		0.2	–	0.8	V
E	Efficiency When Loaded	I _{LOAD} = 8 mA, VCC = 3.3 V		75	–	%
R _{PD}	Data Line Pull Down		14.25	–	24.8	Ω
R _{A_BUS_IN}	A-device V _{BUS} Input Impedance to GND	V _{BUS} is not being driven	40	–	100	kΩ
R _{B_SRP_UP}	B-device V _{BUS} SRP Pull Up	Pull-up voltage = 3.0 V	281	–	–	Ω
R _{B_SRP_DWN}	B-device V _{BUS} SRP Pull Down		656	–	–	Ω

USB Transceiver

USB 2.0-compatible in full- and low-speed modes.

This product was tested as compliant to the USB-IF specification under the test identification number (TID) of 100390449 and is listed on the USB-IF’s integrators list.

AC Timing Characteristics

Reset Timing

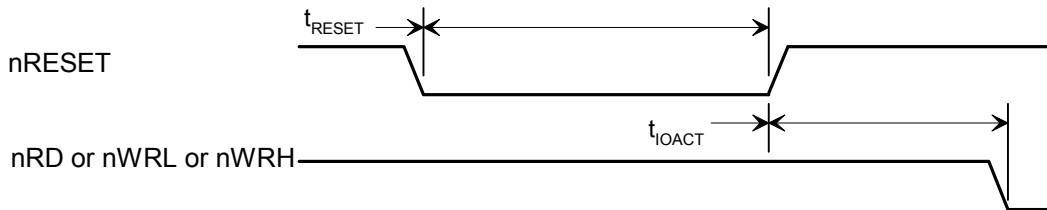

Reset Timing

Parameter	Description	Min.	Typ.	Max.	Unit
t _{RESET}	nRESET Pulse Width	16	–	–	clocks ^[16]
t _{IOACT}	nRESET HIGH to nRD or nWRx Active	200	–	–	μs

Note

16. Clock is 12 MHz nominal.

Clock Timing

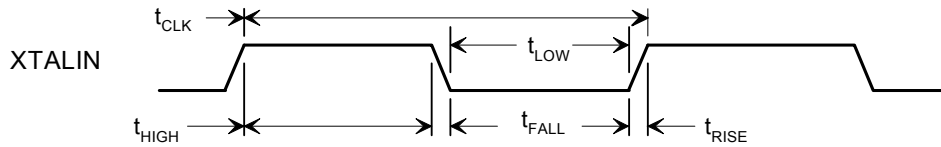

Clock Timing

Parameter	Description	Min.	Typ.	Max.	Unit
f _{CLK}	Clock Frequency	–	12.0	–	MHz
V _{XINH} ^[17]	Clock Input High (XTALOUT left floating)	1.5	3.0	3.6	V
t _{CLK}	Clock Period	83.17	83.33	83.5	ns
t _{HIGH}	Clock High Time	36	–	44	ns
t _{LOW}	Clock Low Time	36	–	44	ns
t _{RISE}	Clock Rise Time	–	–	5.0	ns
t _{FALL}	Clock Fall Time	–	–	5.0	ns
Duty Cycle		45	–	55	%

I²C EEPROM Timing

I²C EEPROM Bus Timing - Serial I/O

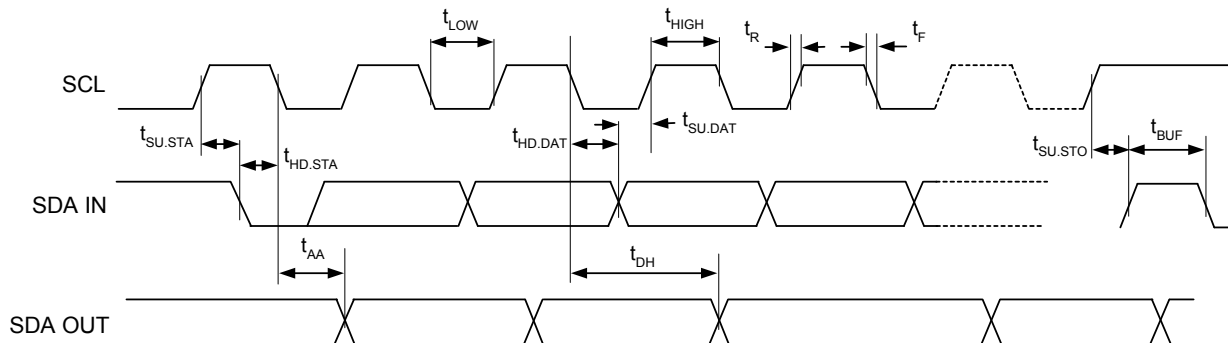

Parameter	Description	Min.	Typical	Max.	Unit
f _{SCL}	Clock Frequency	–	–	400	kHz
t _{LOW}	Clock Pulse Width Low	1300	–	–	ns
t _{HIGH}	Clock Pulse Width High	600	–	–	ns
t _{AA}	Clock Low to Data Out Valid	900	–	–	ns
t _{BUF}	Bus Idle Before New Transmission	1300	–	–	ns
t _{HD.STA}	Start Hold Time	600	–	–	ns
t _{SU.STA}	Start Setup Time	600	–	–	ns
t _{HD.DAT}	Data In Hold Time	0	–	–	ns
t _{SU.DAT}	Data In Setup Time	100	–	–	ns
t _R	Input Rise Time	–	–	300	ns
t _F	Input Fall Time	–	–	300	ns
t _{SU.STO}	Stop Setup Time	600	–	–	ns
t _{DH}	Data Out Hold Time	0	–	–	ns

Note

17. V_{XINH} is required to be 3.0 V to obtain an internal 50/50 duty cycle clock.

Figure 77. HPI (Host Port Interface) Write Cycle Timing

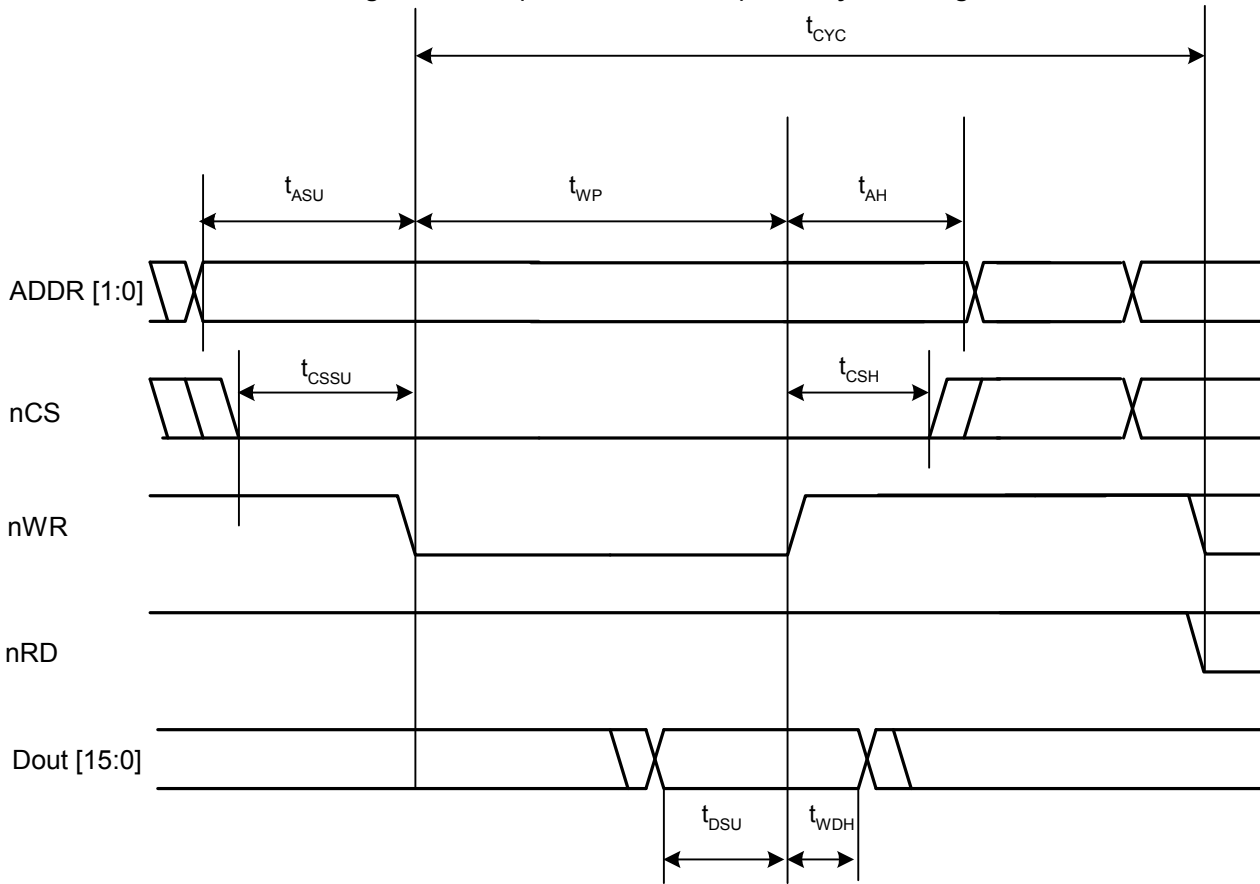

Parameter	Description	Min.	Typical	Max.	Unit
t _{ASU}	Address Setup	-1	-	-	ns
t _{AH}	Address Hold	-1	-	-	ns
t _{CSSU}	Chip Select Setup	-1	-	-	ns
t _{CSH}	Chip Select Hold	-1	-	-	ns
t _{DSU}	Data Setup	6	-	-	ns
t _{WDH}	Write Data Hold	2	-	-	ns
t _{WP}	Write Pulse Width	2	-	-	T ^[18]
t _{CYC}	Write Cycle Time	6	-	-	T ^[18]

Note
18. T = system clock period = 1/48 MHz.

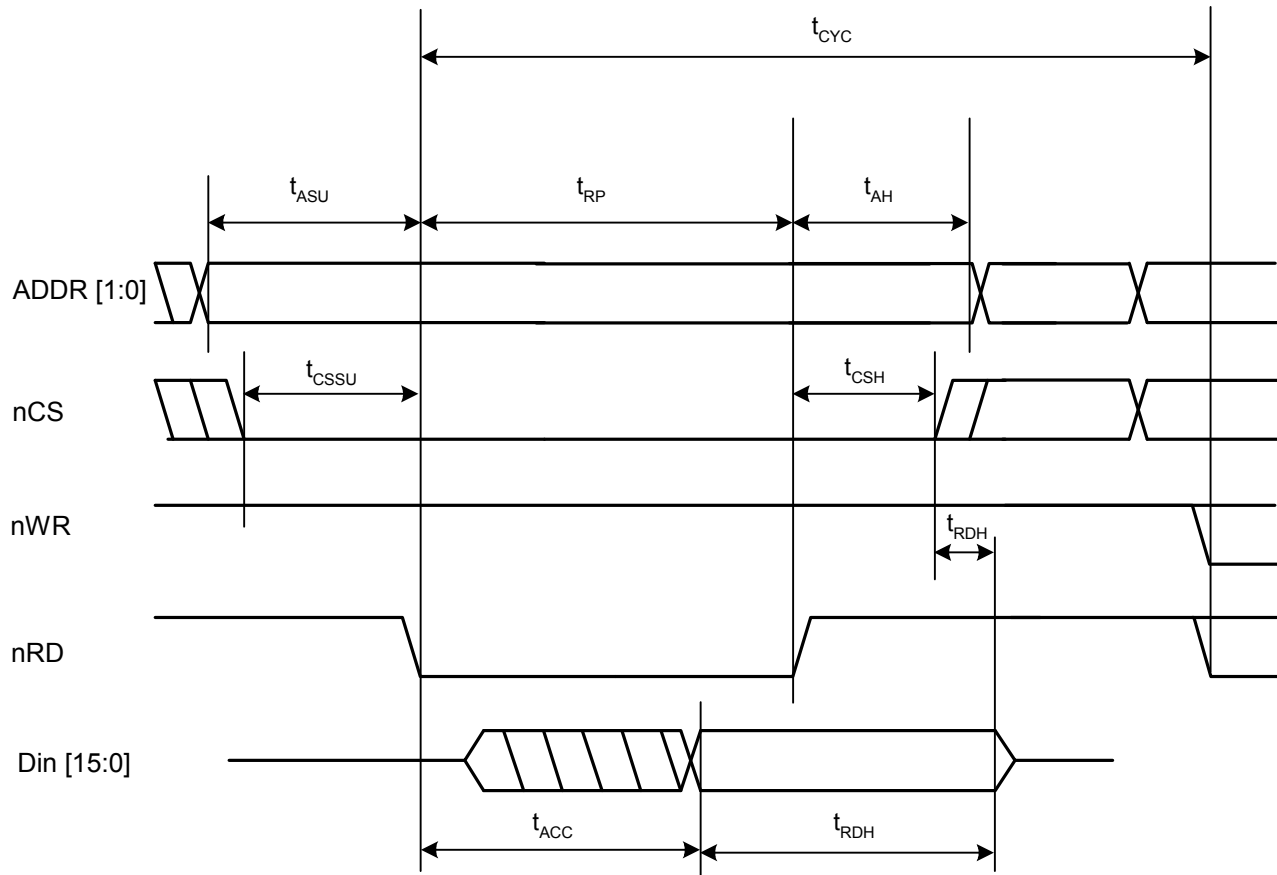
HPI (Host Port Interface) Read Cycle Timing

Parameter	Description	Min.	Typ.	Max.	Unit
t_{ASU}	Address Setup	-1	-	-	ns
t_{AH}	Address Hold	-1	-	-	ns
t_{CSSU}	Chip Select Setup	-1	-	-	ns
t_{CSH}	Chip Select Hold	-1	-	-	ns
t_{ACC}	Data Access Time, from HPI_nRD falling	-	-	1	$T^{[18]}$
t_{RDH}	Read Data Hold, relative to the earlier of HPI_nRD rising or HPI_nCS rising	0	-	7	ns
t_{RP}	Read Pulse Width	2	-	-	$T^{[18]}$
t_{CYC}	Read Cycle Time	6	-	-	$T^{[18]}$

HSS BYTE Mode Transmit

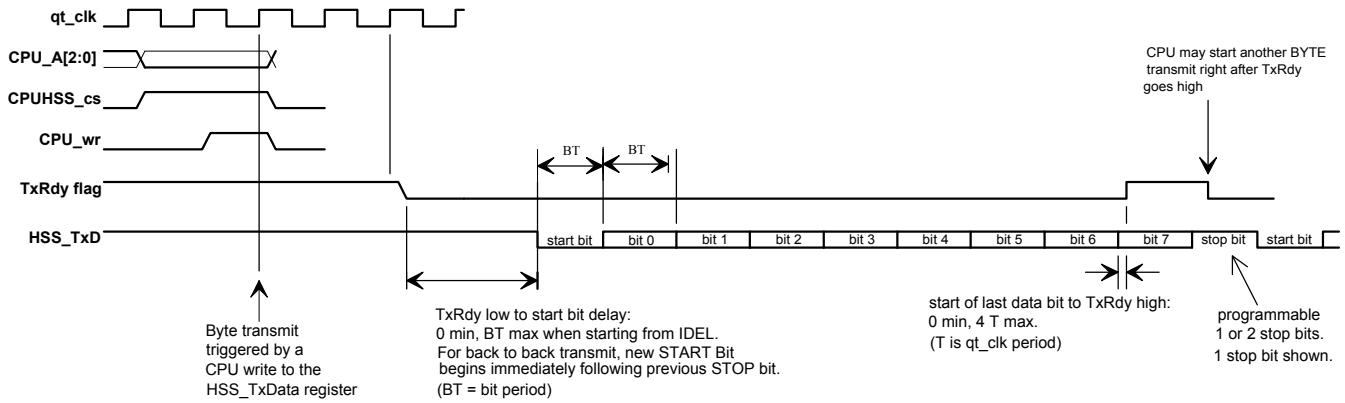

qt_clk, CPU_A, CPUHSS_cs, CPU_wr are internal signals, included in the diagram to illustrate relationship between CPU operations and HSS port operations.

Bit 0 is LSB of data byte. Data bits are HIGH true: HSS_TxD HIGH = data bit value '1'.

BT = bit time = 1/baud rate.

HSS Block Mode Transmit

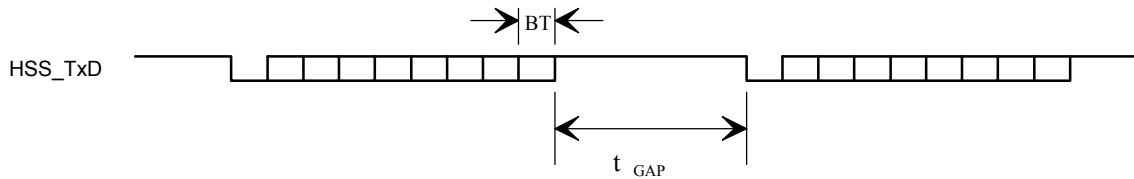

BLOCK mode transmit timing is similar to BYTE mode, except the STOP bit time is controlled by the HSS_GAP value.

The BLOCK mode STOP bit time, $t_{GAP} = (HSS_GAP - 9) BT$, where BT is the bit time, and HSS_GAP is the content of the HSS Transmit Gap register 90xC074].

The default t_{GAP} is 2 BT.

BT = bit time = 1/baud rate.

HSS BYTE and BLOCK Mode Receive

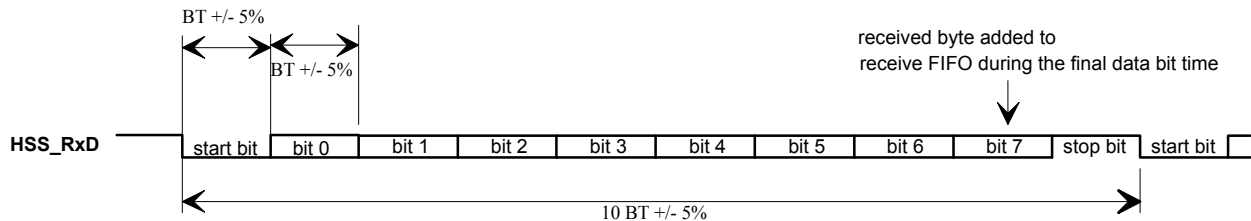

Receive data arrives asynchronously relative to the internal clock.

Incoming data bit rate may deviate from the programmed baud rate clock by as much as $\pm 5\%$ (with HSS_RATE value of 23 or higher).

BYTE mode received bytes are buffered in a FIFO. The FIFO not empty condition becomes the RxRdy flag.

BLOCK mode received bytes are written directly to the memory system.

Bit 0 is LSB of data byte. Data bits are HIGH true: HSS_RxD HIGH = data bit value '1'.

BT = bit time = 1/baud rate.

Hardware CTS/RTS Handshake

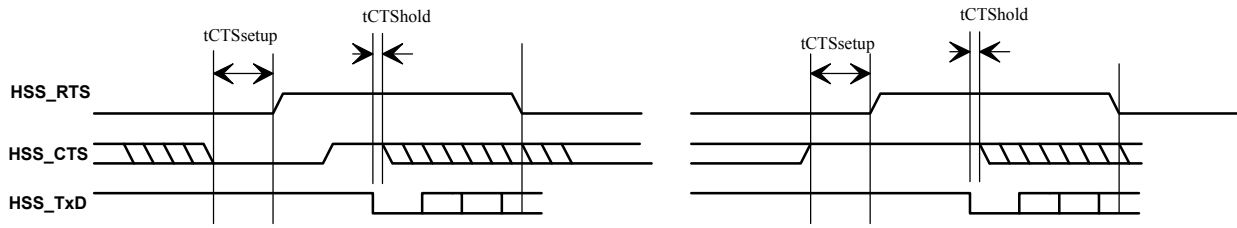

Start of transmission delayed until HSS_CTS goes high

Start of transmission not delayed by HSS_CTS

$t_{CTSset-up}$: HSS_CTS setup time before HSS_RTS = 1.5T min.

$t_{CTShold}$: HSS_CTS hold time after START bit = 0 ns min.

T = 1/48 MHz.

When RTS/CTS hardware handshake is enabled, transmission can be held off by deasserting HSS_CTS at least 1.5T before HSS_RTS. Transmission resumes when HSS_CTS returns HIGH. HSS_CTS must remain HIGH until START bit.

HSS_RTS is deasserted in the third data bit time.

An application may choose to hold HSS_CTS until HSS_RTS is deasserted, which always occurs after the START bit.

Register Summary

Table 42. Register Summary

R/W	Address	Register	Bit 15	Bit 14	Bit 13	Bit 12	Bit 11	Bit 10	Bit 9	Bit 8	Default High			
			Bit 7	Bit 6	Bit 5	Bit 4	Bit 3	Bit 2	Bit 1	Bit 0	Default Low			
R	0x0140	HPI Breakpoint	Address...									0000 0000		
			...Address									0000 0000		
R	0x0142	Interrupt Routing	VBUS to HPI Enable	ID to HPI Enable	SOF/EOP2 to HPI Enable	SOF/EOP2 to CPU Enable	SOF/EOP1 to HPI Enable	SOF/EOP1 to CPU Enable	Reset2 to HPI Enable	HPI Swap 1 Enable	0001 0100			
			Resume2 to HPI Enable	Resume1 to HPI Enable	Reserved		Done2 to HPI Enable	Done1 to HPI Enable	Reset1 to HPI Enable	HPI Swap 0 Enable	0000 0000			
W	1: 0x0144 2: 0x0148	SIEXmsg	Data...									xxxx xxxx		
			...Data									xxxx xxxx		
R/W	0x02n0	Device n Endpoint n Control	Reserved									xxxx xxxx		
			IN/OUT Ignore Enable	Sequence Select	Stall Enable	ISO Enable	NAK Interrupt Enable	Direction Select	Enable	ARM Enable	xxxx xxxx			
R/W	0x02n2	Device n Endpoint n Address	Address...									xxxx xxxx		
			...Address									xxxx xxxx		
R/W	0x02n4	Device n Endpoint n Count	Reserved							Count...		xxxx xxxx		
			...Count									xxxx xxxx		
R/W	0x02n6	Device n Endpoint n Status	Reserved				Overflow Flag	Underflow Flag	OUT Exception Flag	IN Exception Flag	xxxx xxxx			
			Stall Flag	NAK Flag	Length Exception Flag	Set-up Flag	Sequence Status	Timeout Flag	Error Flag	ACK Flag	xxxx xxxx			
R/W	0x02n8	Device n Endpoint n Count Result	Result...									xxxx xxxx		
			...Result									xxxx xxxx		
R	0xC000	CPU Flags	Reserved...						Global Interrupt Enable	Negative Flag	Overflow Flag	Carry Flag	Zero Flag	0000 0000
			...Reserved										000x xxxx	
R/W	0xC002	Bank	Address...									0000 0001		
			...Address						Reserved			000x xxxx		
R	0xC004	Hardware Revision	Revision...									xxxx xxxx		
			...Revision									xxxx xxxx		
R/W	0xC006	GPIO Control	Write Protect Enable	UD	Reserved		SAS Enable	Mode Select		0000 0000				
			HSS Enable	Reserved	SPI Enable	Reserved			Interrupt 0 Polarity Select	Interrupt 0 Enable	0000 0000			
R/W	0xC008	CPU Speed	Reserved...									0000 0000		
			.Reserved						CPU Speed			0000 000F		
R/W	0xC00A	Power Control	Reserved	Host/Device 2 Wake Enable	Reserved	Host/Device 1 Wake Enable	OTG Wake Enable	Reserved	HSS Wake Enable	SPI Wake Enable	0000 0000			
			HPI Wake Enable	Reserved		GPI Wake Enable	Reserved	Boost 3V OK	Sleep Enable	Halt Enable	0000 0000			
R/W	0xC00C	Watchdog Timer	Reserved...									0000 0000		
			...Reserved			Timeout Flag	Period Select	Lock Enable	WDT Enable	Reset Strobe	0000 0000			
R/W	0xC00E	Interrupt Enable	Reserved				OTG Interrupt Enable	SPI Interrupt Enable	Reserved	Host/Device 2 Interrupt Enable	Host/Device 1 Interrupt Enable	0000 0000		
			HSS Interrupt Enable	In Mailbox Interrupt Enable	Out Mailbox Interrupt Enable	Reserved	UART Interrupt Enable	GPIO Interrupt Enable	Timer 1 Interrupt Enable	Timer 0 Interrupt Enable	0001 0000			
R/W	0xC098	OTG Control	Reserved		VBUS Pull-up Enable	Receive Disable	Charge Pump Enable	VBUS Discharge Enable	D+ Pull-up Enable	D- Pull-up Enable	0000 0000			
			D+ Pull-down Enable	D- Pull-down Enable	Reserved			OTG Data Status	ID Status	VBUS Valid Flag	0000 0XXX			
R/W	0: 0xC010 1: 0xC012	Timer n	Count...									1111 1111		
			...Count									1111 1111		
R/W	0xC014	Breakpoint	Address...									0000 0000		
			...Address									0000 0000		
R/W	1: 0xC018 2: 0xC01A	Extended Page n Map	Address...											
			...Address											
R/W	0xC01E	GPIO 0 Output Data	GPIO15	GPIO14	GPIO13	GPIO12	GPIO11	GPIO10	GPIO9	GPIO8	0000 0000			
			GPIO7	GPIO6	GPIO5	GPIO4	GPIO3	GPIO2	GPIO1	GPIO0	0000 0000			
R	0xC020	GPIO 0 Input Data	GPIO15	GPIO14	GPIO13	GPIO12	GPIO11	GPIO10	GPIO9	GPIO8	0000 0000			
			GPIO7	GPIO6	GPIO5	GPIO4	GPIO3	GPIO2	GPIO1	GPIO0	0000 0000			
R/W	0xC022	GPIO 0 Direction	GPIO15	GPIO14	GPIO13	GPIO12	GPIO11	GPIO10	GPIO9	GPIO8	0000 0000			
			GPIO7	GPIO6	GPIO5	GPIO4	GPIO3	GPIO2	GPIO1	GPIO0	0000 0000			

Table 42. Register Summary (continued)

R/W	Address	Register	Bit 15	Bit 14	Bit 13	Bit 12	Bit 11	Bit 10	Bit 9	Bit 8	Default High
			Bit 7	Bit 6	Bit 5	Bit 4	Bit 3	Bit 2	Bit 1	Bit 0	Default Low
R/W	0xC024	GPIO 1 Output Data	GPIO31	GPIO30	GPIO29	Reserved			GPIO24		0000 0000
			GPIO23	GPIO22	GPIO21	GPIO20	GPIO19	Reserved			0000 0000
R	0xC026	GPIO 1 Input Data	GPIO31	GPIO30	GPIO29	Reserved			GPIO24		0000 0000
			GPIO23	GPIO22	GPIO21	GPIO20	GPIO19	Reserved			0000 0000
R/W	0xC028	GPIO 1 Direction	GPIO31	GPIO30	GPIO29	Reserved			GPIO24		0000 0000
			GPIO23	GPIO22	GPIO21	GPIO20	GPIO19	Reserved			0000 0000
R/W	0xC03C	USB Diagnostic	Reserved	Port 2A Diagnostic Enable	Reserved	Port 1A Diagnostic Enable	Reserved...				0000 0000
			...Reserved	Pull-down Enable	LS Pull-up Enable	FS Pull-up Enable	Reserved	Force Select			0000 0000
R/W	0xC070	HSS Control	HSS Enable	RTS Polarity Select	CTS Polarity Select	XOFF	XOFF Enable	CTS Enable	Receive Interrupt Enable	Done Interrupt Enable	0000 0000
			Transmit Done Interrupt Flag	Receive Done Interrupt Flag	One Stop Bit	Transmit Ready	Packet Mode Select	Receive Overflow Flag	Receive Packet Ready Flag	Receive Ready Flag	0000 0000
R/W	0xC072	HSS Baud Rate	Reserved			HSS Baud...					0000 0000
			...Baud								0001 0111
R/W	0xC074	HSS Transmit Gap	Reserved								0000 0000
			Transmit Gap Select								0000 1001
R/W	0xC076	HSS Data	Reserved								xxxx xxxx
			Data								xxxx xxxx
R/W	0xC078	HSS Receive Address	Address...								0000 0000
			...Address								0000 0000
R/W	0xC07A	HSS Receive Counter	Reserved						Counter...		0000 0000
			...Counter								0000 0000
R/W	0xC07C	HSS Transmit Address	Address..								0000 0000
			...Address								0000 0000
R/W	0xC07E	HSS Transmit Counter	Reserved						Counter...		0000 0000
			...Counter								0000 0000
R/W	0xC080 0xC0A0	Host n Control	Reserved								0000 0000
			Preamble Enable	Sequence Select	Sync Enable	ISO Enable	Reserved		Arm Enable		0000 0000
R/W	0xC082 0xC0A2	Host n Address	Address...								0000 0000
			...Address								0000 0000
R/W	0xC084 0xC0A4	Host n Count	Reserved	Port Select	Reserved			Count...		0000 0000	
			...Count								0000 0000
R	0xC086 0xC0A6	Host n PID	Reserved			Overflow Flag	Underflow Flag	Reserved		0000 0000	
			Stall Flag	NAK Flag	Length Exception Flag	Reserved	Sequence Status	Timeout Flag	Error Flag	ACK Flag	0000 0000
W	0xC086 0xC0A4	Host n EP Status	Reserved								0000 0000
			PID Select			Endpoint Select					0000 0000
R	0xC088 0xC0A8	Host n Count Result	Result...								0000 0000
			...Result								0000 0000
W	0xC088 0xC0A8	Host n Device Address	Reserved...								0000 0000
			...Reserved	Address							0000 0000
R/W	0xC08A 0xC0AA	USB n Control	Reserved		Port A D+ Status	Port A D- Status	Reserved	LOA	Mode Select	Reserved	xxxx 0000
			Port A Resistors Enable	Reserved		Port A Force D+ State		Suspend Enable	Reserved	Port A SOF/EOP Enable	0000 0000
R/W	0xC08C	Host 1 Interrupt Enable	VBUS Interrupt Enable	ID Interrupt Enable	Reserved			SOF/EOP Interrupt Enable		Reserved	0000 0000
			Reserved	Port A Wake Interrupt Enable	Reserved	Port A Connect Change Interrupt Enable	Reserved		Done Interrupt Enable		0000 0000
R/W	0xC08C	Device 1 Interrupt Enable	VBUS Interrupt Enable	ID Interrupt Enable	Reserved		SOF/EOP Timeout Interrupt Enable	Reserved	SOF/EOP Interrupt Enable	Reset Interrupt Enable	0000 0000
			EP7 Interrupt Enable	EP6 Interrupt Enable	EP5 Interrupt Enable	EP4 Interrupt Enable	EP3 Interrupt Enable	EP2 Interrupt Enable	EP1 Interrupt Enable	EP0 Interrupt Enable	0000 0000
R/W	0xC08E 0xC0AE	Device n Address	Reserved...								0000 0000
			...Reserved	Address							0000 0000

Table 42. Register Summary (continued)

R/W	Address	Register	Bit 15	Bit 14	Bit 13	Bit 12	Bit 11	Bit 10	Bit 9	Bit 8	Default High	
			Bit 7	Bit 6	Bit 5	Bit 4	Bit 3	Bit 2	Bit 1	Bit 0	Default Low	
R/W	0xC090	Host 1 Status	VBUS Interrupt Flag	ID Interrupt Flag	Reserved			SOF/EOP Interrupt Flag		Reserved	xxxx xxxx	
			Reserved	Port A Wake Interrupt Flag	Reserved	Port A Connect Change Interrupt Flag	Reserved	Port A SE0 Status	Reserved	Done Interrupt Flag	xxxx xxxx	
R/W	0xC090	Device 1 Status	VBUS Interrupt Flag	ID Interrupt Flag	Reserved			SOF/EOP Interrupt Flag		Reset Interrupt Flag	xxxx xxxx	
			EP7 Interrupt Flag	EP6 Interrupt Flag	EP5 Interrupt Flag	EP4 Interrupt Flag	EP3 Interrupt Flag	EP2 Interrupt Flag	EP1 Interrupt Flag	EP0 Interrupt Flag	xxxx xxxx	
R/W	0xC092 0xC0B2	Host n SOF/EOP Count	Reserved		Count...						0010 1110	
			...Count								1110 0000	
R	0xC092 0xC0B2	Device n Frame Number	SOF/EOP Timeout Flag	SOF/EOP Timeout Interrupt Count			Reserved	Frame...				0000 0000
			...Frame									0000 0000
R	0xC094 0xC0B4	Host n SOF/EOP Counter	Reserved		Counter...							
			...Counter									
W	0xC094 0xC0B4	Device n SOF/EOP Count	Reserved		Count...							
			...Count									
R	0xC096 0xC0B6	Host n Frame	Reserved					Frame...				0000 0000
			...Frame									0000 0000
R/W	0xC0AC	Host 2 Interrupt Enable	Reserved						SOF/EOP Interrupt Enable	Reserved	0000 0000	
			Reserved	Port A Wake Interrupt Enable	Reserved	Port A Connect Change Interrupt Enable	Reserved		Done Interrupt Enable	0000 0000		
R/W	0xC0AC	Device 2 Interrupt Enable	Reserved				SOF/EOP Timeout Interrupt Enable	Wake Interrupt Enable	SOF/EOP Interrupt Enable	Reset Interrupt Enable	0000 0000	
			EP7 Interrupt Enable	EP6 Interrupt Enable	EP5 Interrupt Enable	EP4 Interrupt Enable	EP3 Interrupt Enable	EP2 Interrupt Enable	EP1 Interrupt Enable	EP0 Interrupt Enable	0000 0000	
R/W	0xC0B0	Host 2 Status	Reserved					SOF/EOP Interrupt Flag	Reserved	xxxx xxxx		
			Reserved	Port A Wake Interrupt Flag	Reserved	Port A Connect Change Interrupt Flag	Reserved	Port A SE0 Status	Reserved	Done Interrupt Flag	xxxx xxxx	
R/W	0xC0B0	Device 2 Status	Reserved				SOF/EOP Timeout Interrupt Enable	Wake Interrupt Flag	SOF/EOP Interrupt Flag	Reset Interrupt Flag	xxxx xxxx	
			EP7 Interrupt Flag	EP6 Interrupt Flag	EP5 Interrupt Flag	EP4 Interrupt Flag	EP3 Interrupt Flag	EP2 Interrupt Flag	EP1 Interrupt Flag	EP0 Interrupt Flag	xxxx xxxx	
R/W	0xC0C6	HPI Mailbox	Message...								0000 0000	
			...Message								0000 0000	
R/W	0xC0C8	SPI Configuration	3Wire Enable	Phase Select	SCK Polarity Select	Scale Select			Reserved	1000 0000		
			Master Active Enable	Master Enable	SS Enable	SS Delay Select				0001 1111		
R/W	0xC0CA	SPI Control	SCK Strobe	FIFO Init	Byte Mode	FullDuplex	SS Manual	Read Enable	Transmit Ready	Receive Data Ready	0000 0001	
			Transmit Empty	Receive Full	Transmit Bit Length			Receive Bit Length			1000 0000	
R/W	0xC0CC	SPI Interrupt Enable	Reserved...						Receive Interrupt Enable	Transmit Interrupt Enable	Transfer Interrupt Enable	0000 0000
			...Reserved						Receive Interrupt Flag	Transmit Interrupt Flag	Transfer Interrupt Flag	0000 0000
R	0xC0CE	SPI Status	Reserved...						Receive Interrupt Flag	Transmit Interrupt Flag	Transfer Interrupt Flag	0000 0000
			FIFO Error Flag	Reserved			Receive Interrupt Flag	Transmit Interrupt Flag	Transfer Interrupt Flag	0000 0000		
W	0xC0D0	SPI Interrupt Clear	Reserved...						Transmit Interrupt Clear	Transmit Interrupt Clear	0000 0000	
			...Reserved						Transmit Interrupt Clear	Transmit Interrupt Clear	0000 0000	
R/W	0xC0D2	SPI CRC Control	CRC Mode		CRC Enable	CRC Clear	Receive CRC	One in CRC	Zero in CRC	Reserved...	0000 0000	
			...Reserved								0000 0000	
R/W	0xC0D4	SPI CRC Value	CRC..								1111 1111	
			...CRC								1111 1111	

Table 42. Register Summary (continued)

R/W	Address	Register	Bit 15	Bit 14	Bit 13	Bit 12	Bit 11	Bit 10	Bit 9	Bit 8	Default High	
			Bit 7	Bit 6	Bit 5	Bit 4	Bit 3	Bit 2	Bit 1	Bit 0	Default Low	
R/W	0xC0D6	SPI Data Port t	Reserved									xxxx xxxx
			Data									xxxx xxxx
R/W	0xC0D8	SPI Transmit Address	Address...									0000 0000
			...Address									0000 0000
R/W	0xC0DA	SPI Transmit Count	Reserved						Count...			0000 0000
			...Count									0000 0000
R/W	0xC0DC	SPI Receive Address	Address...									0000 0000
			...Address									0000 0000
R/W	0xC0DE	SPI Receive Count	Reserved						Count...			0000 0000
			...Count									0000 0000
R/W	0xC0E0	UART Control	Reserved...			Scale Select		Baud Select		UART Enable		0000 0111
			...Reserved									0000 0000
R	0xC0E2	UART Status	Reserved...							Receive Full	Transmit Full	0000 0000
			...Reserved									0000 0000
R/W	0xC0E4	UART Data	Reserved									0000 0000
			Data									0000 0000
R		HPI Status Port	VBUS Flag	ID Flag	Reserved	SOF/EOP2 Flag	Reserved	SOF/EOP1 Flag	Reset2 Flag	Mailbox In Flag		
			Resume2 Flag	Resume1 Flag	SIE2msg	SIE1msg	Done2 Flag	Done1 Flag	Reset1 Flag	Mailbox Out Flag		

Ordering Information

Table 43. Ordering Information

Ordering Code	Package Type	Pb-Free	Temperature Range
CY7C67200-48BAXI	48-pin FBGA	X	-40 to 85 °C
CY7C67200-48BAXIT	48-pin FBGA, Tape and reel	X	-40 to 85 °C
CY3663	Development Kit		

Ordering Code Definitions

CY 7 C 67 XXX - XX XXXX I I

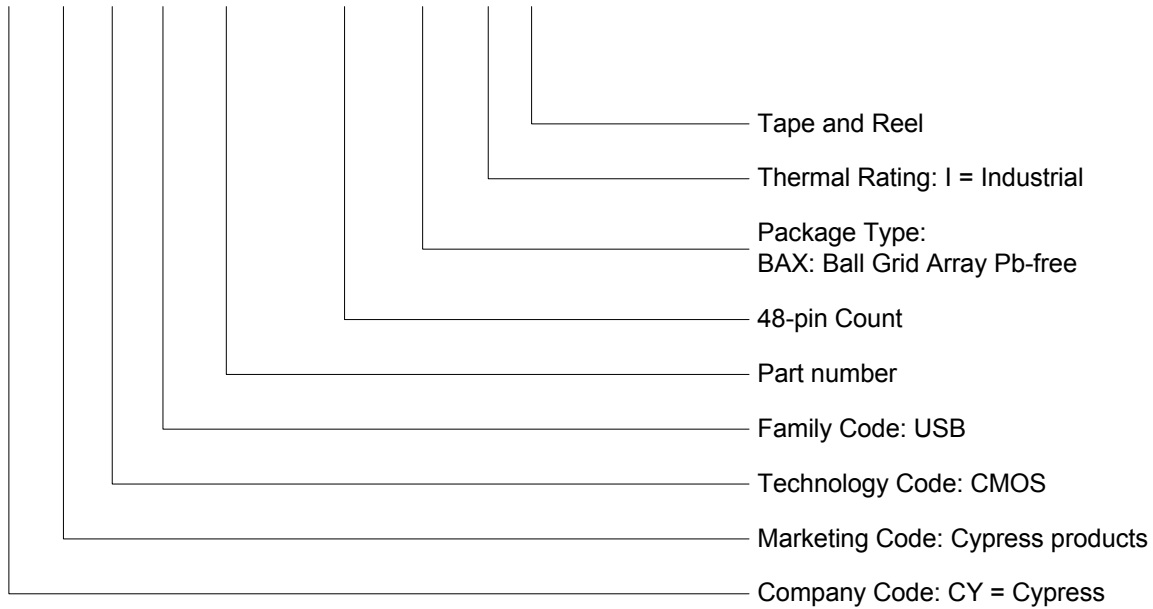

Package Diagram

Figure 78. 48-ball FBGA (7.00 mm × 7.00 mm × 1.2 mm) BA48 Package Outline

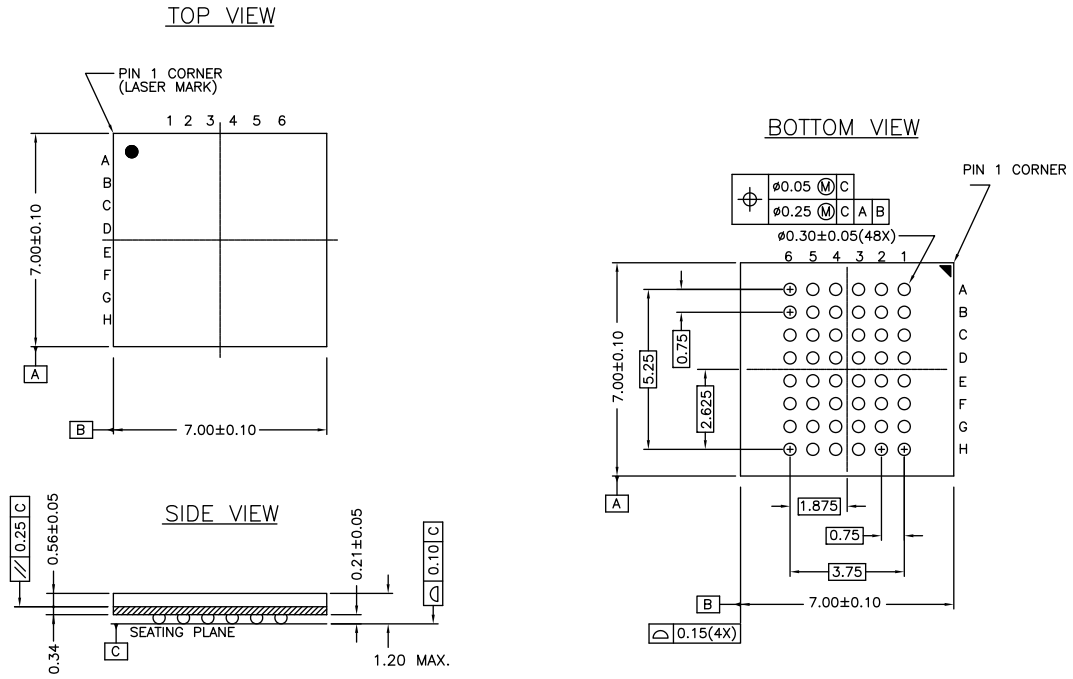

51-85096 *J

Acronyms

Table 44. Acronyms Used in this Document

Acronym	Description
AC	alternating current
AEC	Automotive Electronics Council
CPU	central processing unit
CRC	cyclic redundancy check
DC	direct current
DMA	direct memory access
EEPROM	electronically erasable programmable read only memory
EOP	end of packet
XRAM	external ram memory
FIFO	first in first out
GPIO	general purpose input/output
HSS	high speed serial
HPI	host port interface
IDE	integrated device electronics
I ² C	inter-integrated circuit
KVM	keyboard-video-mouse
OTG	on-the-go protocol
PLL	phase locked loop
POR	power-on reset
PIO	programmed input/output
PWM	pulse width modulation
RAM	random access memory
ROM	read only memory
SPI	serial peripheral interface
SIE	serial-interface-engine
SE0	single ended zero
SOF	start of frame
SRAM	static random access memory
TQFP	thin quad flat pack
TTL	transistor-transistor logic
UART	universal asynchronous receiver/transmitter
USB	universal serial bus
WDT	watchdog timer

Document Conventions

Units of Measure

Table 45. Units of Measure

Symbol	Unit of Measure
°C	degree Celsius
MHz	megahertz
μA	microampere
μF	microfarad
μs	microsecond
μW	microwatt
mA	milliampere
ms	millisecond
mV	millivolt
mW	milliwatt
ns	nanosecond
ppm	parts per million
pF	picofarad
V	volt
W	watt

Errata

This section describes the errata for the CY7C67200. Details include errata trigger conditions, scope of impact, available workaround, and silicon revision applicability.

Contact your local Cypress Sales Representative if you have questions.

Part Numbers Affected

Part Number	Device Characteristics
CY7C67200	All Packages

CY7C67200 Qualification Status

In Production

CY7C67200 Errata Summary

The following table defines the errata applicability to available CY7C67200 family devices. An "X" indicates that the errata pertains to the selected device.

Note Errata items, in the table below, are hyperlinked. Click on any item entry to jump to its description.

Items	CY7C67200	Silicon Revision	Fix Status
1. HPI Write to SIE Registers	X	A	No fix is currently planned for future silicon versions. Use workaround.
2. IDE Register Read When GPIO24 Pin is Low	X	A	No fix is currently planned for future silicon versions. Use workaround.
3. UART Does Not Recognize Framing Errors	X	A	No fix is currently planned for future silicon versions. Use workaround.
4. UART Does Not Override GPIO Control Register	X	A	No fix is currently planned for future silicon versions. Use workaround.
5. VBUS Interrupt (VBUS Valid) Requires Debouncing	X	A	No fix is currently planned for future silicon versions. Use workaround.
6. Coupled SIE Interrupt Enable Bits	X	A	No fix is currently planned for future silicon versions. Use workaround.
7. Un-Initialized SIEmsg Registers	X	A	No fix is currently planned for future silicon versions. Use workaround.
8. BIOS USB Peripheral Mode: Descriptor Length	X	A	No fix is currently planned for future silicon versions. Use workaround.
9. Peripheral Short Packet Issue	X	A	Will be fixed in future silicon revision. Use workaround.
10. Data Toggle Corruption Issue	X	A	Will be fixed in future silicon revision. Use workaround.

1. HPI Write to SIE Registers

■ Problem Definition

Writing to the SIE2 Control register via HPI can corrupt the SIE1 control register.

Writing to the SIE1 Control register via HPI can corrupt the SIE2 control register.

■ Parameters Affected

SIE control registers

■ Trigger Condition(S)

When an external processor accesses the SIE1 or SIE2 register at the same time the internal CY16 CPU is also accessing the opposite SIE, the SIE accessed by the CY16 CPU will be corrupted.

For example, the external processor writes a value of 0x80 to the SIE2 register 0xC0B0 while the internal CY16 is doing a read/write to the SIE1 register 0xC08C, the SIE1 register 0xC08C, will be corrupted with the value 0x80.

■ Scope of Impact

If the internal CPU and external CPU access the SIEs at the same time, contention will occur resulting in incorrect data in one of the SIE registers.

■ Workaround

1. Use the LCP COMM_WRITE_CTRL_REG to handle the writing to SIE registers.
2. Use download code to handle SIE WRITE commands.
3. Avoid accessing SIE register from the external CPU. For example: Route all the SIE interrupts to the software mailbox interrupt registers 0x144 and 0x148. This requires user to create download code.

■ Fix Status

Use workaround. No fix is currently planned for future silicon revisions. An implementation example is included in the Cypress Windows CE driver.

2. IDE Register Read When GPIO24 Pin is Low

■ Problem Definition

Part does not service USB ISRs when GPIO24 pin (also labeled as HPI_INT and IORDY) is low and any IDE register is read.

■ Parameters Affected

USB ISRs do not get serviced.

■ Trigger Conditions

The IDE registers (0xC050 through 0xC06E) should not be read unless IDE is being used. Debuggers that read all memory locations while single stepping can cause this situation to manifest itself.

■ Scope of Impact

If debugging and using this pin, your application will appear to hang.

■ Workaround

When running in stand-alone mode, avoid using the GPIO24 pin if possible.

■ Fix Status

Other workarounds being investigated. No fix is currently planned for future silicon revisions.

3. UART Does Not Recognize Framing Errors

■ Problem Definition

The UART is not designed to recognize framing errors.

■ Parameters Affected

UART serial communications.

■ Trigger Conditions

Some platforms can cause EZ-OTG to see a string of NULL characters and cause the UART to get out of sync.

■ Scope of Impact

This can cause the UART to lose connection with the host during serial communications. One example of this is if the UART is used as the debug port to the PC. This problem has occurred on, but is not limited to, Dell machines running WinXP or Win2k.

■ Workaround

For general use, there is no workaround. If this problem is experienced while debugging, try running the debugger on a different Host (PC/OS). Otherwise the USB port can be used for the debugging interface.

■ Fix Status

No fix is currently planned for future silicon versions.

4. UART Does Not Override GPIO Control Register

■ Problem Definition

When the UART is enabled, the GPIO Control Register still has control over GPIO 6 (UART RX pin). When enabled, the UART should override the GPIO Control Register, which defaults to setting the pin as an input.

■ Parameters Affected

UART serial communications.

■ Trigger Conditions

Enabling UART

■ Scope of Impact

GPIO 6 UART RX pin is controlled by GPIO Control Register and defaults to an input. The UART mode does not override the GPIO control register for this pin and can be inadvertently configured as an output.

■ Workaround

Ensure the GPIO Control Register is written appropriately to set GPIO6 as an input when the UART is enabled.

■ Fix Status

No fix is currently planned for future silicon versions.

5. VBUS Interrupt (VBUS Valid) Requires Debouncing

■ Problem Definition

The VBUS interrupt in the Host/Device Status Registers [0xC090 and 0xC0B0] and OTG Control Register [0xC098] triggers multiple times whenever VBUS is turned on. It should only trigger once when VBUS rises above 4.4 V and once when VBUS falls from above 4.4 V to 0 V.

■ Parameters Affected

Electrical.

■ Trigger Conditions

VBUS turned on.

■ Scope of Impact

Host/Device Registers and OTG Control Register trigger multiple times.

■ Workaround

When reading the status of this interrupt, a software debounce should be implemented.

■ Fix Status

No fix is currently planned for future silicon versions.

6. Coupled SIE Interrupt Enable Bits

■ Problem Definition

Host/Device 1 SIE events will still trigger an interrupt when only the Host/Device 2 SIE Interrupt Enable is set and vice versa.

■ Parameters Affected

Host/Device SIE Interrupts.

■ Trigger Conditions

Setting only 1 Host/Device SIE Interrupt Enable.

■ Scope of Impact

The Host/Device global Interrupt Enable bits can not be used to disable each Host/Device SIE independently. These bits are found in the Interrupt Enable Register (0xC00E).

■ Workaround

If an SIE Interrupt is desired, both Host/Device 1 and Host/Device 2 Interrupt Enable bits should be set in the global Interrupt Enable Register (0xC00E). To properly mask an SIE Interrupt to a single SIE, the lower level Host/Device Interrupt Enable Registers (0xC08C and 0xC0AC) must be used. For example, setting the Host/Device 2 IE Register to 0x0000 will prevent any Host/Device 2 events from generating a Host/Device Interrupt. To disable all SIE interrupts, both Host/Device Interrupt Enable bits in the Interrupt Enable Register should be cleared.

■ Fix Status

No fix is currently planned for future silicon versions. Examples provided in the Development Kit Software.

7. Un-Initialized SIExmsg Registers

■ Problem Definition

The SIE1msg and SIE2msg Registers [0x0144 and 0x0148] are not initialized at power up.

■ Parameters Affected

HPI interrupts.

■ Trigger Conditions

Power-up initialization.

■ Scope of Impact

If using the HPI interface in coprocessor mode, random data will be written to the SIE1msg and SIE2msg Registers [0x0144 and 0x0148] at power up. This will cause two improper HPI interrupts (HPI_INTR) to occur, one for each of the two SIExmsg Registers.

■ Workaround

The external processor should clear the SIExmsg Registers [0x0144 and 0x0148] shortly after nRESET is de-asserted and prior to the expected processing of proper HPI interrupts (generally 10ms after nRESET is de-asserted.)

■ Fix Status

No fix is currently planned for future silicon versions.

8. BIOS USB Peripheral Mode: Descriptor Length

■ Problem Definition

The BIOS will not properly return a descriptor or set of descriptors if the length is a multiple of the control endpoint's maximum packet size.

■ Parameters Affected

Control Endpoint maximum packet size.

■ Trigger Conditions

Get Descriptor requests.

■ Scope of Impact

If the descriptor length is a multiple of the maximum packet size, the BIOS will respond with a STALL instead of a zero-length data packet for the final IN request.

■ Workaround

If the requested descriptor length is a multiple of the maximum packet size, then either the maximum packet size or the descriptor length needs to change. A descriptor length can be increased by simply adding a padded byte to the end of a descriptor and increasing the descriptor Length byte by one. Section 9.5 (Descriptor) of the USB2.0 specification allows a descriptor length to be larger than the value defined in the specification.

■ Fix Status

No fix is currently planned for future silicon versions.

9. Peripheral Short Packet Issue

■ Problem Definition

When a SIE is configured as a peripheral, the SUSBx_RECEIVE function does not invoke the callback function when it receives a short packet.

■ Parameters Affected

SIEx Endpoint x Interrupt (Interrupt 32-47).

■ Trigger Conditions

This issue is seen when a SIE is configured as a peripheral during an OUT data transfer when the host sends a zero length or short packet. If this occurs the BIOS will behave as if a full packet was received and will continue to accept data until the Device n Endpoint n Count Register value is satisfied.

■ Scope of Impact

All peripheral functions are susceptible to this as it is a normal occurrence with USB traffic.

■ Workaround

To fix this problem the SIEx Endpoint x Interrupt must be replaced for any peripheral endpoint that is configured as an OUT endpoint.

1. Acquire the file called `usb1.s` from Cypress Support or by downloading a newer version of the frameworks that has had this fix applied and includes `usb1.s`.
2. Modify `fwxcfg.h` in your project to have the following flags and define/undef the fix for the endpoints you are using:

```
#define FIX_USB1_EP1
#define FIX_USB1_EP2
#undef  FIX_USB1_EP3
#undef  FIX_USB1_EP4
#undef  FIX_USB1_EP5
#undef  FIX_USB1_EP6
#undef  FIX_USB1_EP7

#undef  FIX_USB2_EP1
#undef  FIX_USB2_EP2
#undef  FIX_USB2_EP3
#undef  FIX_USB2_EP4
#undef  FIX_USB2_EP5
#undef  FIX_USB2_EP6
#undef  FIX_USB2_EP7
```

3. Add the new `usb1.s` to the included assembly source files in the make file.

For example: `ASM_SRC := startup.s isrs.s usb1.s`

4. Add `usb_init` somewhere in the startup code. This will likely be in `fwxmain.c` as demonstrated below:

```
void fwx_program_init(void)
{
    void usb_init();           /* define the prototype */
    usb_init();
    fwx_init();               /* Initialize everything in the base framework. */
}
```

5. Build the project using the modified make file.

■ Fix Status

The ROM version of the BIOS will be updated during any future silicon rolls. No current roll of the part currently exists.

10.Data Toggle Corruption Issue

■ Problem Definition

When a SIE is configured as a peripheral, data toggle corruption as specified in the USB 2.0 spec, section 8.6.4, does not work as specified.

■ Parameters Affected

SIEx Endpoint x Interrupt (Interrupt 32-47).

■ Trigger Conditions

This issue is seen when a SIE is configured as a peripheral and the host sends an incorrect data toggle. According to the USB specification, when an incorrect data toggle is seen from the host the peripheral should throw away the data but increment the data toggle bit to re-synchronize the data toggle bits. In the current ROM BIOS the SIEx Endpoint x Interrupt will ignore the data toggle error and accept the data.

■ Scope of Impact

All peripheral functions are susceptible to this as it is a normal occurrence with USB traffic.

■ Workaround

To fix this problem the SIEx Endpoint x Interrupt must be replaced for any endpoint that is configured as an OUT endpoint.

1. Acquire the file called `usb1.s` from Cypress Support or by downloading a newer version of the frameworks that has this included.
2. Modify `fwxcfg.h` in your project to have the following flags and define/undef the fix for the endpoints you are using:

```
#define FIX_USB1_EP1
#define FIX_USB1_EP2
#undef FIX_USB1_EP3
#undef FIX_USB1_EP4
#undef FIX_USB1_EP5
#undef FIX_USB1_EP6
#undef FIX_USB1_EP7
```

```
#undef FIX_USB2_EP1
#undef FIX_USB2_EP2
#undef FIX_USB2_EP3
#undef FIX_USB2_EP4
#undef FIX_USB2_EP5
#undef FIX_USB2_EP6
#undef FIX_USB2_EP7
```

3. Add the new `usb1.s` to the included assembly source files in the make file.
For example: `ASM_SRC := startup.s isrs.s usb1.s`
4. Add `usb_init` somewhere in the startup code. This will likely be in `fwxmain.c` as demonstrated below:

```
void fwx_program_init(void)
{
void usb_init(); /* define the prototype */

usb_init();

fwx_init(); /* Initialize everything in the base framework. */
}
```

5. Build the project using the modified make file.

■ Fix Status

The ROM version of the BIOS will be updated during any future silicon rolls. No current roll of the part currently exists.

Document History Page

Document Title: CY7C67200, EZ-OTG™ Programmable USB On-The-Go Host/Peripheral Controller Document Number: 38-08014				
Revision	ECN	Orig. of Change	Submission Date	Description of Change
**	111872	MUL	03/22/02	New data sheet.
*A	116988	MUL	08/23/02	Preliminary data sheet
*B	124954	MUL	04/10/03	Added Memory Map Section and Ordering Information Section Moved Functional Register Map Tables into Register section General Clean-up Changed from "Preliminary" to "Preliminary Confidential"
*C	126211	MUL	05/23/03	Added Interface Description Section and Power Savings and Reset Section Added Char Data General Clean-up Removed DRAM, MDMA, and EPP Added "Programmable" to the title page
*D	127334	KKV	05/29/03	Corrected font to enable correct symbol display
*E	129394	MUL	10/07/03	Final Data Sheet Changed Memory Map Section Added USB OTG Logo General Clean-up
*F	472875	ARI	See ECN	Removed "power consumption" bullet from the Features bullet list. Corrected number GPIO[31:20] to read GPIO[31:30] in Section "Standalone Mode" . Made sentence into a Note in Section "Reset Pin" and repeated the note in Section "Host Port Interface (HPI)" . Corrected the Host/Device 1 Interrupt Enable (Bit 8) Information in Section "Interrupt Enable Register [0xC00E] [R/W]" . Corrected data on Write Protect Enable (Bit 15) Section "GPIO Control Register [0xC006] [R/W]" to read "the GPIO Mode Select [15:8] bits are read only until a chip reset". Re-wrote the Register Description in Section "SIEXmsg Register [W] [10]" . Put document on 2-column template and corrected grammar. Put the figure captions at the top of the figures per new template specifications. Added Static Discharge Voltage information in Section "Absolute Maximum Ratings" Added compliance statement and TID in Section "USB Transceiver" .
*G	567317	KKVTMP	See ECN	Added the lead free information on the Ordering Information Section. Implemented the new template with no numbers on the headings.
*H	3378752	NMMA	09/21/11	Updated template and styles according to current Cypress standards. Updated pin description in Ordering Information table. Added Acronyms and Units of Measure. Added Ordering Code Definitions.
*I	3997630	PRJI	05/11/2013	Added Errata .

Document History Page (continued)

Document Title: CY7C67200, EZ-OTG™ Programmable USB On-The-Go Host/Peripheral Controller Document Number: 38-08014				
Revision	ECN	Orig. of Change	Submission Date	Description of Change
*J	4082823	PRJI	07/31/2013	Added Errata footnotes (Note 1, 2, 7, 8, 9, 10, 11). Updated Interface Descriptions : Updated UART Interface : Added Note 1 and referred the same note in the heading. Updated I2C EEPROM Interface : Added Note 2 and referred the same note in the heading. Updated Registers : Updated Processor Control Registers : Updated Interrupt Enable Register [0xC00E] [R/W] : Added Note 7 and referred the same note in the heading. Updated General USB Registers : Added Note 8 and referred the same note in the heading. Updated OTG Control Registers : Added Note 9 and referred the same note in the heading. Updated HPI Registers : Updated SIEXmsg Register [W] [10] : Added Note 10 and referred the same note in the heading. Updated Pin Descriptions : Added Note 11 and referred the same note in "GPIO24/INT/IRQ0" pin. Updated to new template. Completing Sunset Review.
*K	5514428	RAJV	11/08/2016	Updated Package Diagram : spec 51-85096 – Changed revision from *I to *J. Updated to new template. Completing Sunset Review.
*L	5726446	AESATMP7	05/04/2017	Updated Cypress Logo and Copyright.

Sales, Solutions, and Legal Information

Worldwide Sales and Design Support

Cypress maintains a worldwide network of offices, solution centers, manufacturer's representatives, and distributors. To find the office closest to you, visit us at [Cypress Locations](#).

Products

ARM® Cortex® Microcontrollers	cypress.com/arm
Automotive	cypress.com/automotive
Clocks & Buffers	cypress.com/clocks
Interface	cypress.com/interface
Internet of Things	cypress.com/iot
Lighting & Power Control	cypress.com/powerpsoc
Memory	cypress.com/memory
PSoC	cypress.com/psoc
Touch Sensing	cypress.com/touch
USB Controllers	cypress.com/usb
Wireless/RF	cypress.com/wireless

PSoC® Solutions

[PSoC 1](#) | [PSoC 3](#) | [PSoC 4](#) | [PSoC 5LP](#) | [PSoC 6](#)

Cypress Developer Community

[Forums](#) | [Projects](#) | [Video](#) | [Blogs](#) | [Training](#) | [Components](#)

Technical Support

cypress.com/support

© Cypress Semiconductor Corporation, 2002-2017. This document is the property of Cypress Semiconductor Corporation and its subsidiaries, including Spansion LLC ("Cypress"). This document, including any software or firmware included or referenced in this document ("Software"), is owned by Cypress under the intellectual property laws and treaties of the United States and other countries worldwide. Cypress reserves all rights under such laws and treaties and does not, except as specifically stated in this paragraph, grant any license under its patents, copyrights, trademarks, or other intellectual property rights. If the Software is not accompanied by a license agreement and you do not otherwise have a written agreement with Cypress governing the use of the Software, then Cypress hereby grants you a personal, non-exclusive, nontransferable license (without the right to sublicense) (1) under its copyright rights in the Software (a) for Software provided in source code form, to modify and reproduce the Software solely for use with Cypress hardware products, only internally within your organization, and (b) to distribute the Software in binary code form externally to end users (either directly or indirectly through resellers and distributors), solely for use on Cypress hardware product units, and (2) under those claims of Cypress's patents that are infringed by the Software (as provided by Cypress, unmodified) to make, use, distribute, and import the Software solely for use with Cypress hardware products. Any other use, reproduction, modification, translation, or compilation of the Software is prohibited.

TO THE EXTENT PERMITTED BY APPLICABLE LAW, CYPRESS MAKES NO WARRANTY OF ANY KIND, EXPRESS OR IMPLIED, WITH REGARD TO THIS DOCUMENT OR ANY SOFTWARE OR ACCOMPANYING HARDWARE, INCLUDING, BUT NOT LIMITED TO, THE IMPLIED WARRANTIES OF MERCHANTABILITY AND FITNESS FOR A PARTICULAR PURPOSE. To the extent permitted by applicable law, Cypress reserves the right to make changes to this document without further notice. Cypress does not assume any liability arising out of the application or use of any product or circuit described in this document. Any information provided in this document, including any sample design information or programming code, is provided only for reference purposes. It is the responsibility of the user of this document to properly design, program, and test the functionality and safety of any application made of this information and any resulting product. Cypress products are not designed, intended, or authorized for use as critical components in systems designed or intended for the operation of weapons, weapons systems, nuclear installations, life-support devices or systems, other medical devices or systems (including resuscitation equipment and surgical implants), pollution control or hazardous substances management, or other uses where the failure of the device or system could cause personal injury, death, or property damage ("Unintended Uses"). A critical component is any component of a device or system whose failure to perform can be reasonably expected to cause the failure of the device or system, or to affect its safety or effectiveness. Cypress is not liable, in whole or in part, and you shall and hereby do release Cypress from any claim, damage, or other liability arising from or related to all Unintended Uses of Cypress products. You shall indemnify and hold Cypress harmless from and against all claims, costs, damages, and other liabilities, including claims for personal injury or death, arising from or related to any Unintended Uses of Cypress products.

Cypress, the Cypress logo, Spansion, the Spansion logo, and combinations thereof, WICED, PSoC, CapSense, EZ-USB, F-RAM, and Traveo are trademarks or registered trademarks of Cypress in the United States and other countries. For a more complete list of Cypress trademarks, visit cypress.com. Other names and brands may be claimed as property of their respective owners.