

Power-Voltage Monitoring IC with Watchdog Timer

The MB3793 is an integrated circuit to monitor power voltage; it incorporates a watchdog timer. A reset signal is output when the power is cut or falls abruptly. When the power recovers normally after resetting, a power-on reset signal is output to microprocessor units (MPUs). An internal watchdog timer with two inputs for system operation diagnosis can provide a fail-safe function for various application systems.

Model No.	Marking Code	Detection voltage
MB3793-34A	3793AJ	3.4 V

Features

- Precise detection of power voltage fall: $\pm 2.5\%$
- Detection voltage with hysteresis
- Low power dispersion: $I_{CC} = 38 \mu\text{A}$ (Typ)
- Internal dual-input watchdog timer
- Watchdog timer halt function
- Independently-set watchdog and reset times

Application

Arcade Amusement etc.

Contents

Pin Assignment 3
Pin Description 3
Block Diagram 4
Block Functions 5
Absolute Maximum Ratings 6
Recommended Operating Conditions 6
Electrical Characteristics 7
 DC Characteristics 7
 AC Characteristics 8
Timing Diagram 9
 Basic operation (Positive clock pulse) 9
 Basic operation (Negative clock pulse) 10
 Single-clock input monitoring
 (Positive clock pulse) 11
 Inhibition operation (Positive clock pulse) 12
 Clock pulse input supplementation
 (Positive clock pulse) 13

Operation Sequence 14
 Positive clock pulse input 14
 Negative clock pulse input 14
 Single-clock input monitoring 14
 Description of Operations 14
Typical Characteristics 16
Application Example 19
 Supply voltage monitor and watchdog timer 19
 Supply voltage monitor and watchdog timer stop 20
Usage Precaution 21
Ordering Information 21
RoHS Compliance Information of
Lead (Pb) Free version 22
Labeling Sample (Lead free version) 22
Marking Format (Lead Free version) 22
MB3793-34APNF Recommended Conditions
Of Moisture Sensitivity Level 23
Package Dimensions 2..... 4
Document History 25

1. Pin Assignment

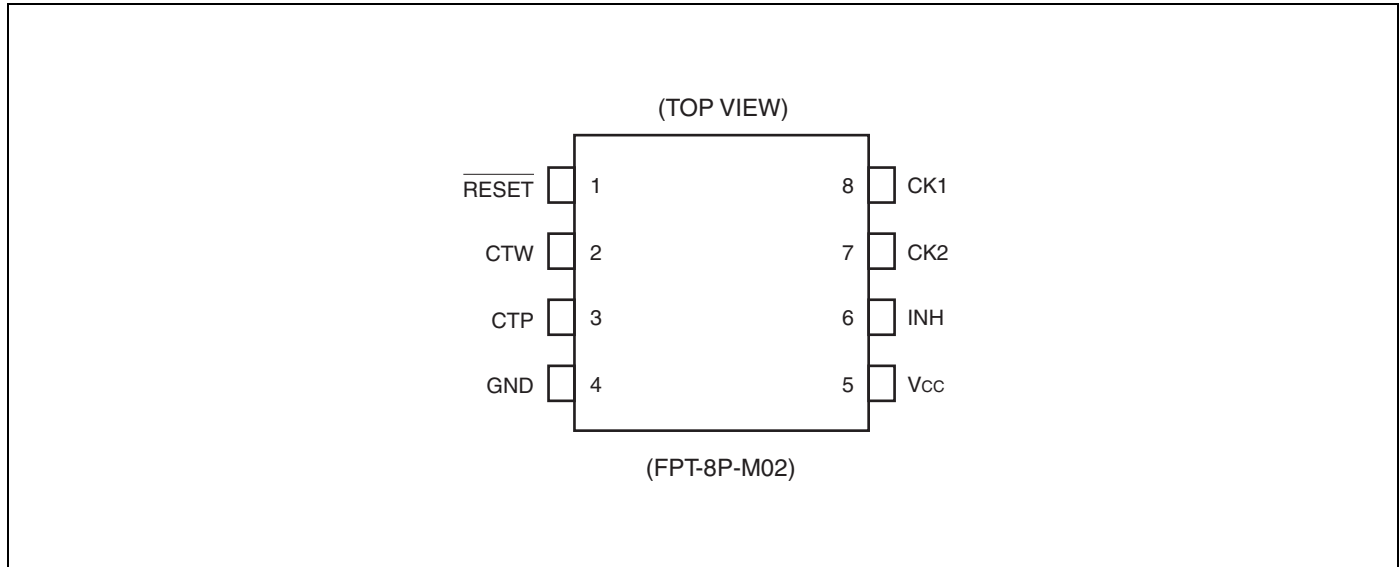

2. Pin Description

Pin No.	Symbol	Description
1	$\overline{\text{RESET}}$	Outputs reset pin
2	CTW	Sets watchdog timer monitoring time pin
3	CTP	Sets power-on reset hold time pin
4	GND	Ground pin
5	VCC	Power supply pin
6	INH	This pin forces the watchdog timer on/off. When this pin is High level, the watchdog timer is stopped.
7	CK2	Inputs clock 2 pin
8	CK1	Inputs clock 1 pin

3. Block Diagram

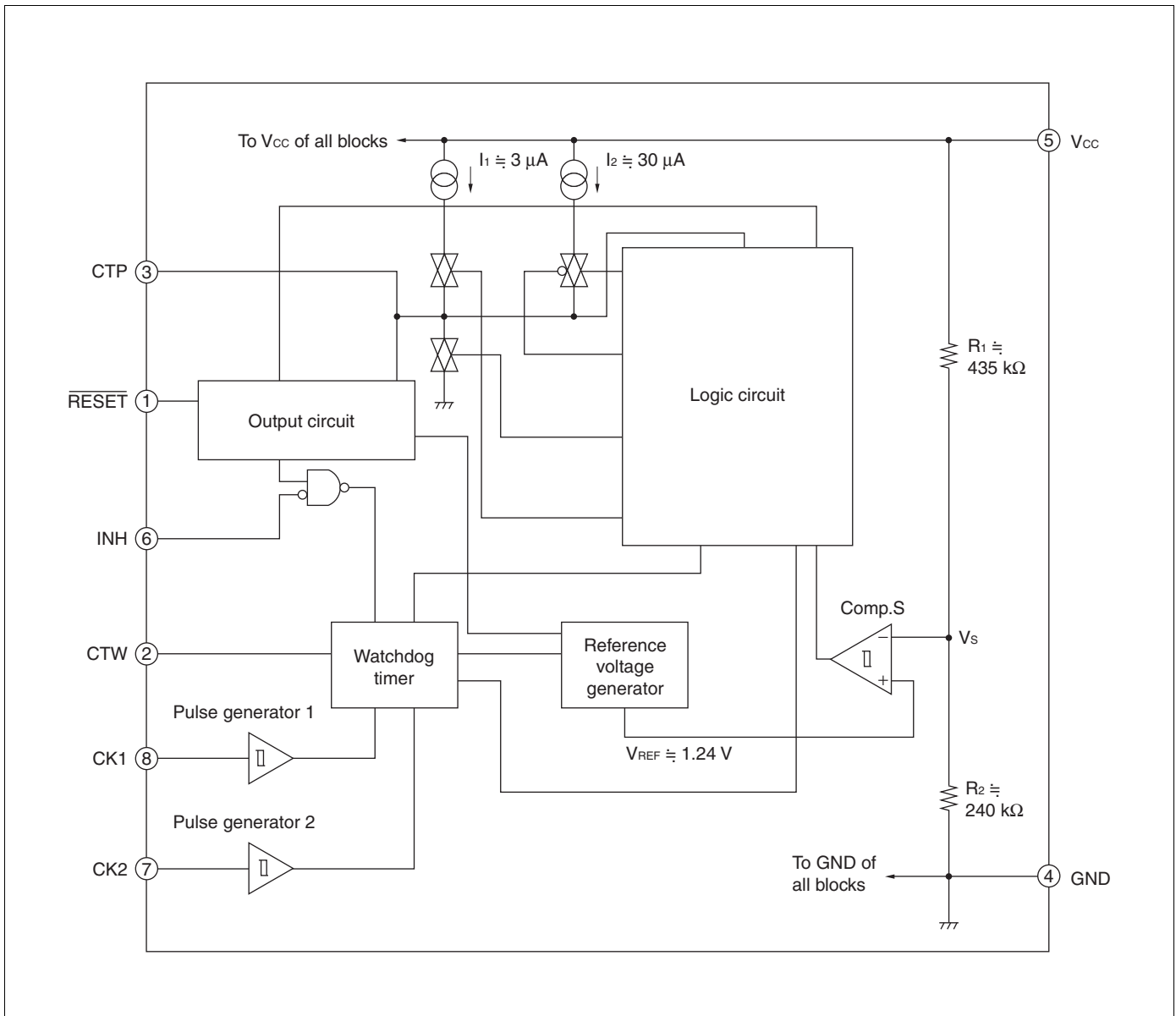

4. Block Functions

1. Comp.S

Comp.S is a comparator with hysteresis to compare the reference voltage with a voltage (V_s) that is the result of dividing the power voltage (V_{CC}) by resistors R_1 and R_2 . When V_s falls below 1.24 V, a reset signal is output. This function enables the MB3793 to detect an abnormality within 1 μ s when the power is cut or falls abruptly.

2. Output circuit

The output circuit has a comparator to control the reset signal ($\overline{\text{RESET}}$) output. When the voltage at the CTP pin for setting the power-on reset hold time exceeds the threshold voltage, resetting is canceled.

Since the reset ($\overline{\text{RESET}}$) output buffer has the CMOS organization, no pull-up resistor is needed.

3. Pulse generator

The pulse generator generates pulses when the voltage at the CK1 and CK2 input clock pins changes from Low level to High level (positive-edge trigger) and exceeds the threshold voltage; it sends the clock signal to the watchdog timer.

4. Watchdog timer

The watchdog timer can monitor two clock pulses. Short-circuit the CK1 and CK2 clock pins to monitor a single clock pulse.

5. Logic circuit

Logic circuit controls charging and discharging of the power-on reset hold time setting capacity (C_{TP}) on a signal of Comp.S and Watchdog timer.

5. Absolute Maximum Ratings

Parameter	Symbol	Conditions	Rating		Unit
			Min	Max	
Power supply voltage*	V_{CC}	—	-0.3	+7	V
Input voltage*	CK1	V_{CK1}	-0.3	$V_{CC} + 0.3$ ($\leq +7$)	V
	CK2	V_{CK2}			
	INH	V_{INH}			
Reset output voltage*	$\overline{\text{RESET}}$	V_{OL}	-0.3	$V_{CC} + 0.3$ ($\leq +7$)	V
		V_{OH}			
Reset output current		I_{OL} I_{OH}	-10	+10	mA
Power dissipation	P_D	$T_a \leq +85^\circ\text{C}$	—	200	mW
Storage temperature	T_{stg}	—	-55	+125	$^\circ\text{C}$

* : The voltage is based on the ground voltage (0 V).

WARNING: Semiconductor devices can be permanently damaged by application of stress (voltage, current, temperature, etc.) in excess of absolute maximum ratings. Do not exceed these ratings.

6. Recommended Operating Conditions

Parameter	Symbol	Conditions	Value			Unit
			Min	Typ	Max	
Power supply voltage	V_{CC}	—	1.2	5.0	6.0	V
Reset ($\overline{\text{RESET}}$) output current	I_{OL}	—	0	—	+ 5	mA
	I_{OH}	—	-5	—	0	
Power-on reset hold time setting capacity	C_{TP}	—	0.001	0.1	10	μF
Watchdog-timer monitoring time setting capacity*	C_{TW}	—	0.001	0.01	1	μF
Operating ambient temperature	T_a	—	-40	+25	+85	$^\circ\text{C}$

* : The watchdog timer monitor time range depends on the rating of the setting capacitor.

WARNING: The recommended operating conditions are required in order to ensure the normal operation of the semiconductor device. All of the device's electrical characteristics are warranted when the device is operated within these ranges.

Always use semiconductor devices within their recommended operating condition ranges.

Operation outside these ranges may adversely affect reliability and could result in device failure.

No warranty is made with respect to uses, operating conditions, or combinations not represented on the data sheet. Users considering application outside the listed conditions are advised to contact their representatives beforehand.

7. Electrical Characteristics

7.1 DC Characteristics

 $(V_{CC} = +5\text{ V}, T_a = +25^\circ\text{C})$

Parameter	Symbol	Conditions	Value			Unit	
			Min	Typ	Max		
Power current	ICC1	After exit from reset	—	38	50	μA	
Detection voltage	VSL	VCC falling	Ta = +25°C	3.32	3.40	3.48	V
			Ta = -40 to +85°C	3.27*	3.40	3.53*	
	VSH	VCC rising	Ta = +25°C	3.40	3.48	3.56	V
			Ta = -40 to +85°C	3.35*	3.48	3.61*	
Detection voltage hysteresis difference	VSHYS	VSH - VSL	35	80	120	mV	
CK input threshold voltage	VCIH	—	1.4*	1.9	2.5	V	
	VCIL	—	0.8	1.3	1.8*	V	
CK input hysteresis	VCHYS	—	0.4*	0.6	0.8*	V	
INH input voltage	VIIH	—	3.5	—	V_{CC}	V	
	VIIIL	—	0	—	0.8	V	
Input current (CK1,CK2,INH)	IIH	$V_{IH} = V_{CC}$	—	0	1.0	μA	
	IIL	$V_{IL} = 0\text{ V}$	-1.0	0	—	μA	
Reset output voltage	VOH	$\overline{\text{IRESET}} = -5\text{ mA}$	4.5	4.75	—	V	
	VOL	$\overline{\text{IRESET}} = +5\text{ mA}$	—	0.12	0.4	V	
Reset-output minimum power voltage	VCCL	$\overline{\text{IRESET}} = +50\text{ }\mu\text{A}$	—	0.8	1.2	V	

* : This parameter is guaranteed by design, which is not supported by a final test.

7.2 AC Characteristics

 (V_{CC} = +5 V, T_a = +25°C)

Parameter	Symbol	Conditions	Value			Unit	
			Min	Typ	Max		
Power-on reset hold time	tPR	CTP = 0.1 μF	80	130	180	ms	
Watchdog timer monitoring time	tWD	CTW = 0.01 μF CTP = 0.1 μF	7.5	15	22.5	ms	
Watchdog timer reset time	tWR	CTP = 0.1 μF	5	10	15	ms	
CK input pulse width	tCKW	—	500	—	—	ns	
CK input pulse cycle	tCKT	—	20	—	—	μs	
Reset ($\overline{\text{RESET}}$) output transition time	Rising	tr*	CL = 50 pF	—	—	500	ns
	Falling	tf*	CL = 50 pF	—	—	500	ns

*: The voltage range is 10% to 90% at testing the reset output transition time.

8. Timing Diagram

8.1 Basic operation (Positive clock pulse)

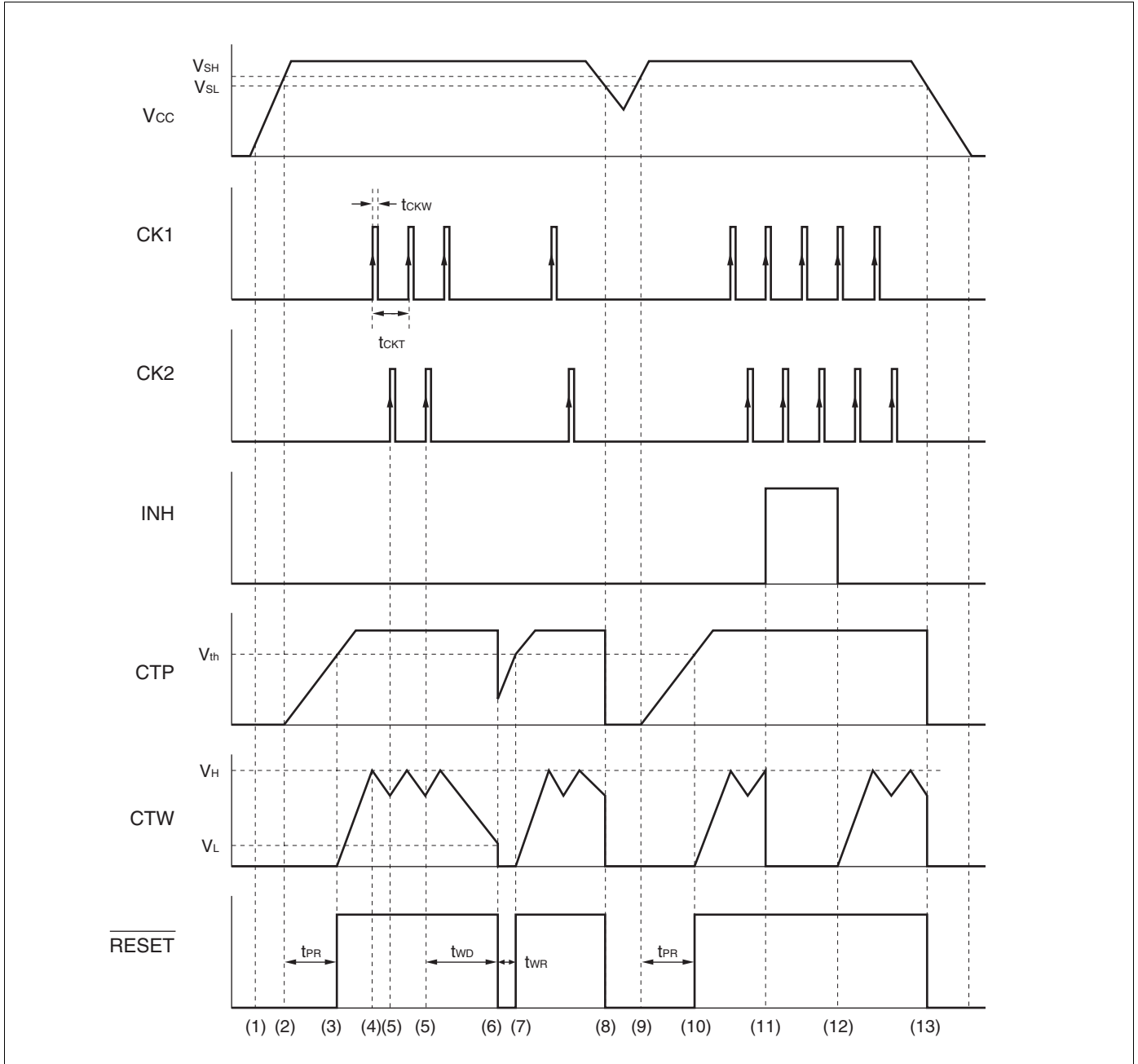

8.2 Basic operation (Negative clock pulse)

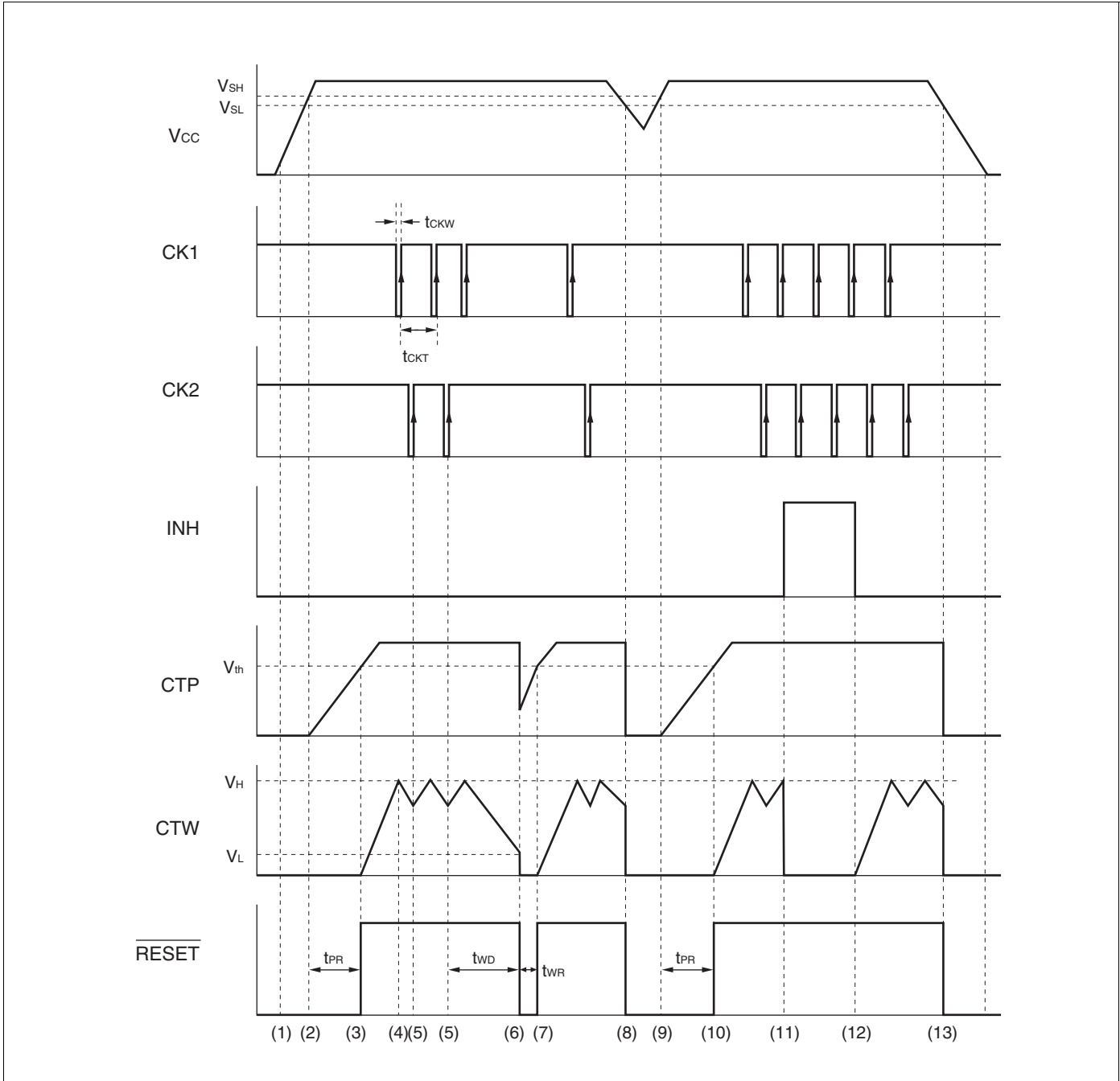

8.3 Single-clock input monitoring (Positive clock pulse)

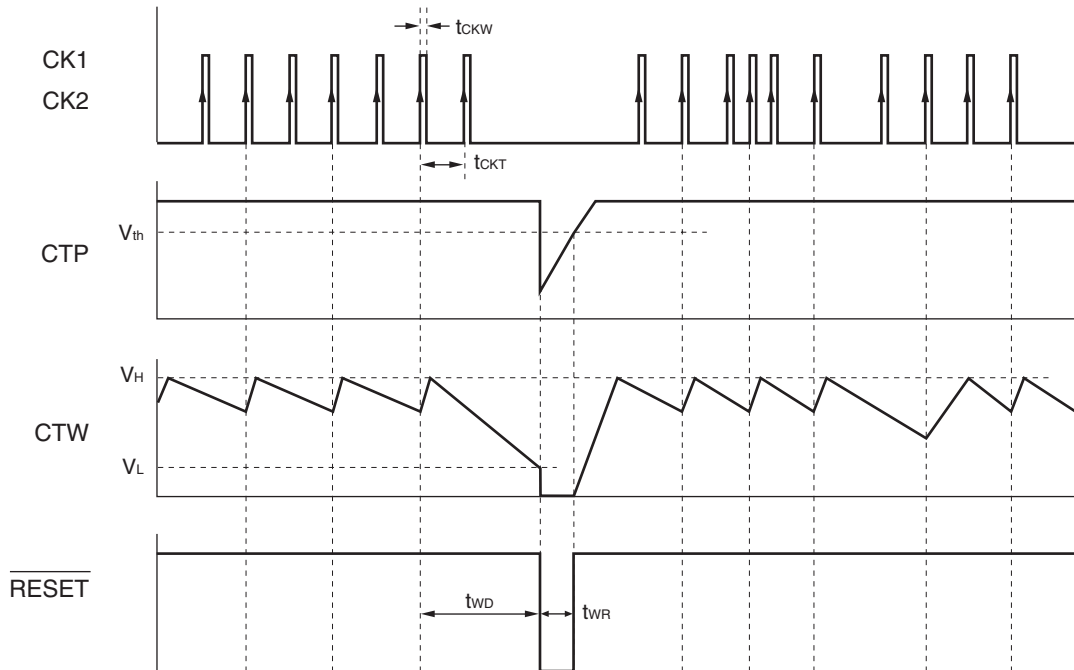

Note : The MB3793 can monitor only one clock.
 The MB3793 checks the clock signal at every other input pulse.
 Therefore, set watchdog timer monitor time t_{WD} to the time that allows the MB3793 to monitor the period twice as long as the input clock pulse.

8.4 Inhibition operation (Positive clock pulse)

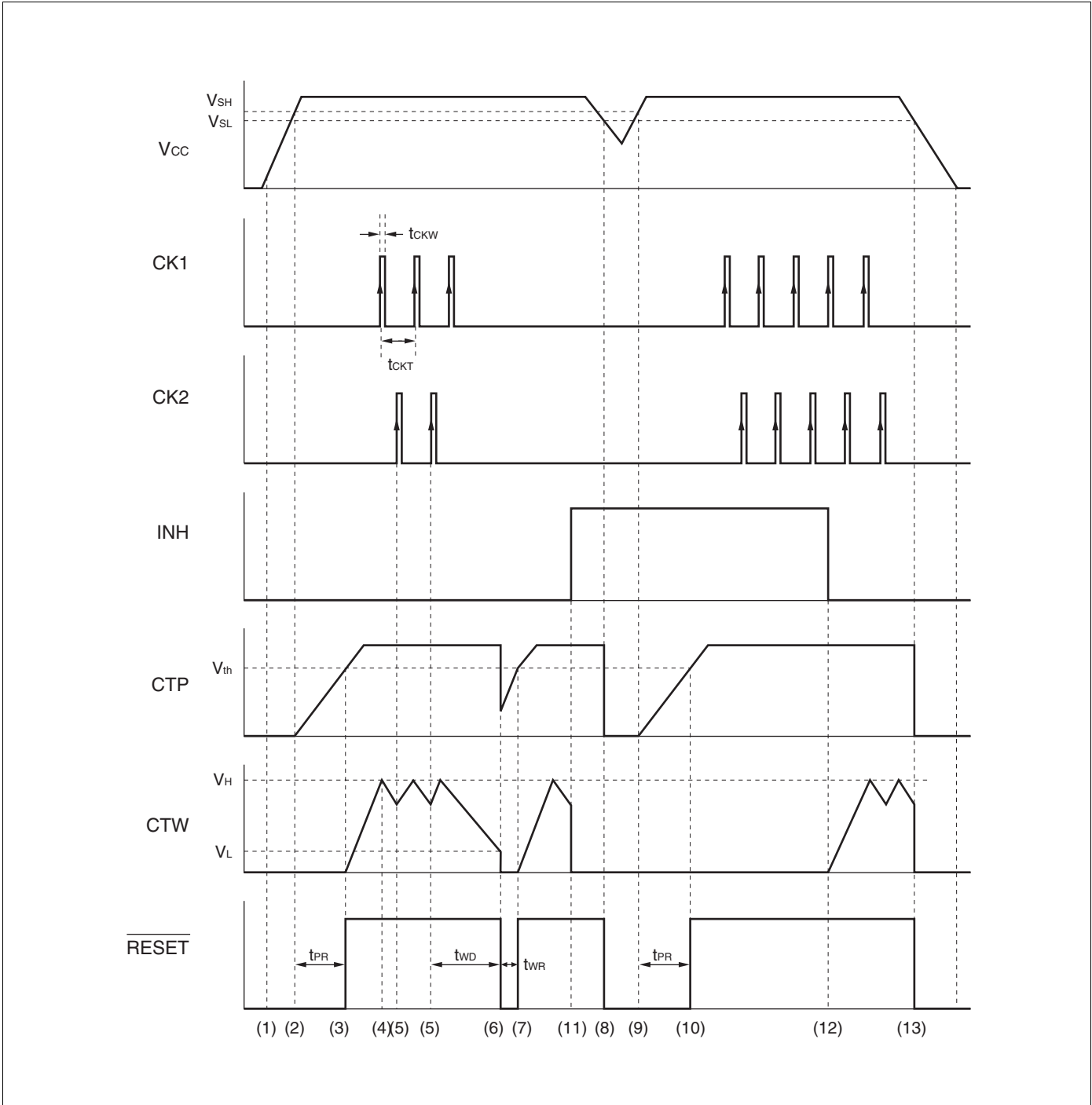

8.5 Clock pulse input supplementation (Positive clock pulse)

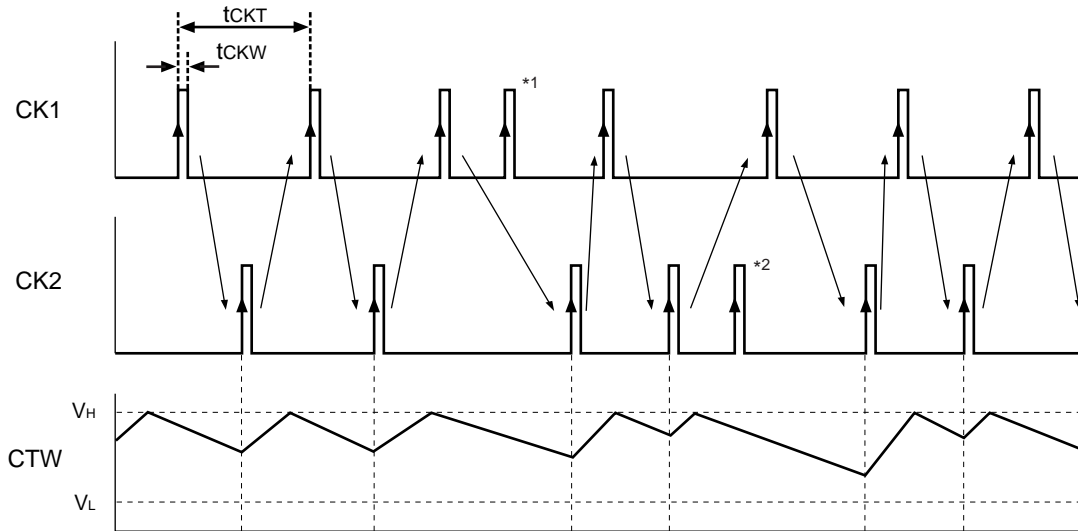

Note : The MB3793 watchdog timer monitors Clock1 (CK1) and Clock2 (CK2) pulses alternately.
 When a CK2 pulse is detected after detecting a CK1 pulse, the monitoring time setting capacity (C_{TW}) switches to charging from discharging.
 When two consecutive pulses occur on one side of this alternation before switching, the second pulse is ignored.
 In the above figure, pulse *1 and *2 are ignored.

9. Operation Sequence

9.1 Positive clock pulse input

Refer to “8.1. Basic operation (positive clock pulse)” under “8. Timing Diagram”.

9.2 Negative clock pulse input

Refer to “8.2. Basic operation (negative clock pulse)” under “8. Timing Diagram”.

The MB3793 operates in the same way whether it inputs positive or negative pulses.

9.3 Single-clock input monitoring

To use the MB3793 while monitoring only one clock, connect clock pins CK1 and CK2.

Although the MB3793 operates basically in the same way as when monitoring two clocks, it monitors the clock signal at every other input pulse.

Refer to “8.3. Single-clock input monitoring (positive clock pulse)” under “8. Timing Diagram”.

9.4 Description of Operations

The numbers given to the following items correspond to numbers 1 to 13 used in “8. Timing Diagram”.

1. The MB3793 outputs a reset signal when the supply voltage (V_{CC}) reaches about 0.8 V (V_{CCL}).
2. If V_{CC} reaches or exceeds the rise-time detected voltage V_{SH} , the MB3793 starts charging the power-on reset hold time setting capacitor C_{TP} . At this time, the output remains in a reset state. The V_{SH} value is 3.48 V (Typ).
3. When C_{TP} has been charged for a certain period of time T_{PR} (until the CTP pin voltage exceeds the threshold voltage (V_{th}) after the start of charging), the MB3793 cancels the reset (setting the RESET pin to “H” level from “L” level).
The V_{th} value is about 3.6 V with $V_{CC} = 5.0$ V

The power-on reset hold time t_{PR} is set with the following equation:

$$t_{PR} \text{ (ms)} \approx A \times C_{TP} \text{ (\mu F)}$$

The value of A is about 1300 with $V_{CC} = 5.0$ V. The MB3793 also starts charging the watchdog timer monitor time setting capacitor (C_{TW}).

4. When the voltage at the watchdog timer monitor time setting pin C_{TW} reaches the “H” level threshold voltage V_H , the CTW switches from the charge state to the discharge state.
The value of V_H is always about 1.24 V regardless of the detected voltage.
5. If the CK2 pin inputs a clock pulse (positive edge trigger) when the C_{TW} is being discharged in the CK1-CK2 order or simultaneously, the C_{TW} switches from the discharge state to the charge state.
The MB3793 repeats operations 4 and 5 as long as the CK1/CK2 pin inputs clock pulses with the system logic circuit operating normally.
6. If no clock pulse is fed to the CK1 or CK2 pin within the watchdog timer monitor time t_{WD} due to some problem with the system logic circuit, the CTW pin is set to the “L” level threshold voltage V_L or less and the MB3793 outputs a reset signal (setting the RESET pin to “L” level from “H” level).
The value of V_L is always about 0.24 V regardless of the detected voltage.
The watchdog timer monitor time t_{WD} is set with the following equation:
$$t_{WD} \text{ (ms)} \approx B \times C_{TW} \text{ (\mu F)} + C \times C_{TP} \text{ (\mu F)}$$

The value of B is hardly affected by the power supply voltage; it is about 1500 with $V_{CC} = 5.0$ V.
The value of C is 0.
For this reason:
$$t_{WD} \text{ (ms)} \approx B \times C_{TW} \text{ (\mu F)}$$

7. When a certain period of time t_{WR} has passed (until the CTP pin voltage reaches or exceeds V_{th} again after recharging the C_{TP}), the MB3793 cancels the reset signal and starts operating the watchdog timer.
The watchdog timer monitor reset time t_{WR} is set with the following equation:
 $t_{WR} \text{ (ms)} \approx D \times C_{TP} \text{ (}\mu\text{F)}$
The value of D is 100 with $V_{CC} = 5.0 \text{ V}$.
The MB3793 repeats operations (4) and (5) as long as the CK1/CK2 pin inputs clock pulses. If no clock pulse is input, the MB3793 repeats operations (6) and (7).
8. If V_{CC} is lowered to the fall-time detected voltage (V_{SL}) or less, the CTP pin voltage decreases and the MB3793 outputs a reset signal (setting the RESET pin to "L" level from "H" level).
The value of V_{SL} is 3.40 V (Typ).
9. When V_{CC} reaches or exceeds V_{SH} again, the MB3793 starts charging the C_{TP} .
10. When the CTP pin voltage reaches or exceeds V_{th} , the MB3793 cancels the reset and restarts operating the watchdog timer. It repeats operations 4 and 5 as long as the CK1/CK2 pin inputs clock pulses.
11. Making the inhibit pin active (setting the INH pin to "H" from "L") forces the watchdog timer to stop operation.
This stops only the watchdog timer, leaving the MB3793 monitoring V_{CC} (operations 8 to 10).
The watchdog timer remains inactive unless the inhibit input is canceled.
The inhibition (INH) pin must be connecting a voltage of more low impedance, to evade of the noise.
12. Cancelling the inhibit input (setting the INH pin to "L" from "H") restarts the watchdog timer.
13. The reset signal is output when the power supply is turned off to set V_{CC} to V_{SL} or less.

1. Equation of time-setting capacitances (C_{TP} and C_{TW}) and set time

$$t_{PR} \text{ [ms]} \approx A \times C_{TP} \text{ [}\mu\text{F]}$$

$$t_{WD} \text{ [ms]} \approx B \times C_{TW} \text{ [}\mu\text{F]} + C \times C_{TP} \text{ [}\mu\text{F]}$$

$$\text{However, when } C_{TP}/C_{TW} \approx 10 \text{ or less, } t_{WD} \text{ [ms]} \approx B \times C_{TW} \text{ [}\mu\text{F]}$$

$$t_{WR} \text{ [ms]} \approx D \times C_{TP} \text{ [}\mu\text{F]}$$

Values of A, B, C, and D

A	B	C	D	Remark
1300	1500	0	100	$V_{CC} = 5.0 \text{ V}$

Note: The width of value of t_{PR} , t_{WD} and t_{WR} becomes the same ratio as width (Min, Max) of each specification value.

2. Example (when $C_{TP} = 0.1 \mu\text{F}$ and $C_{TW} = 0.01 \mu\text{F}$)

time (ms)	Symbol	$V_{CC} = 5.0 \text{ V}$
	t_{PR}	130
	t_{WD}	15
	t_{WR}	10

10. Typical Characteristics

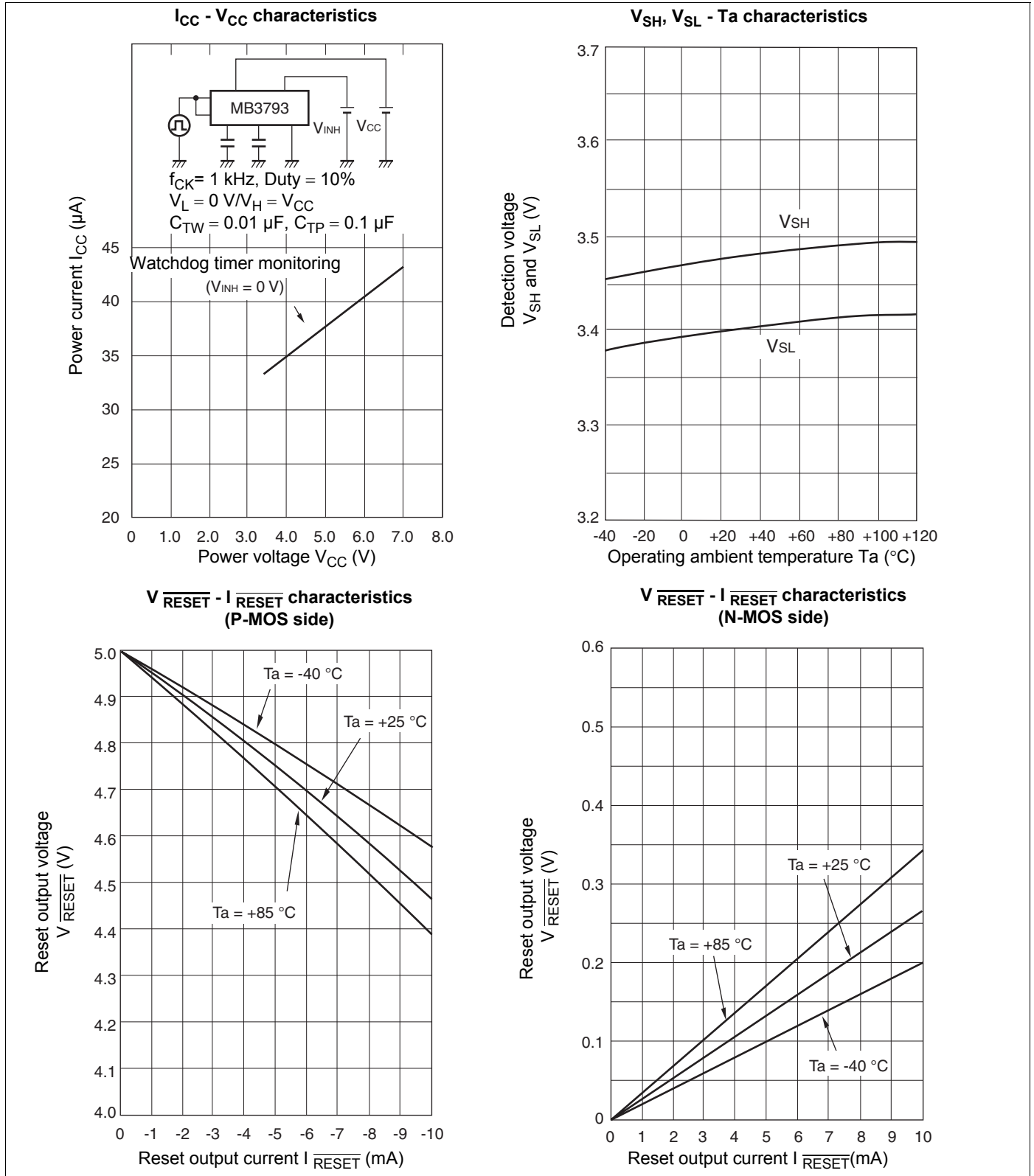

(Continued)

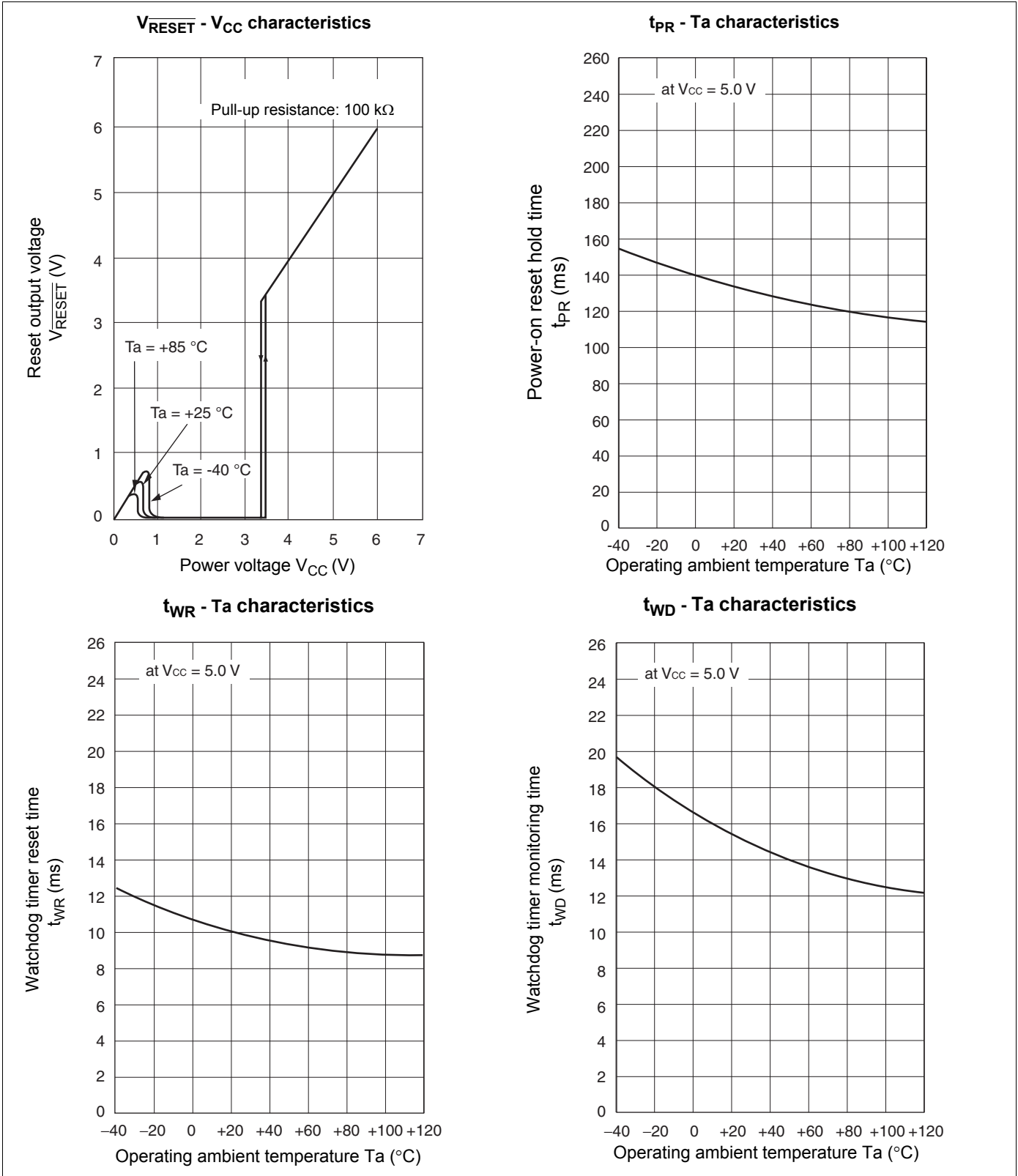

(Continued)

(Continued)

$t_{PR} - C_{TP}$ characteristics

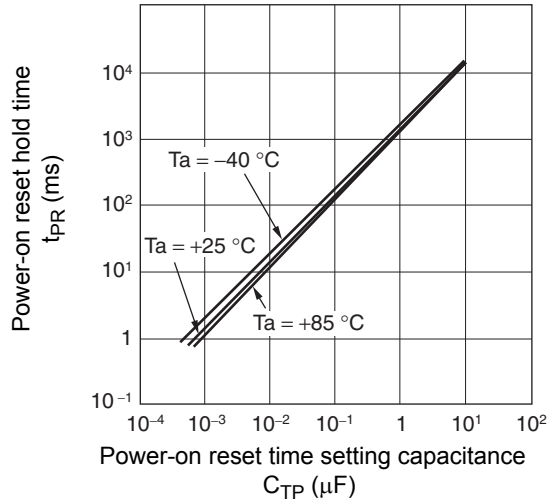

$t_{WR} - C_{TP}$ characteristics

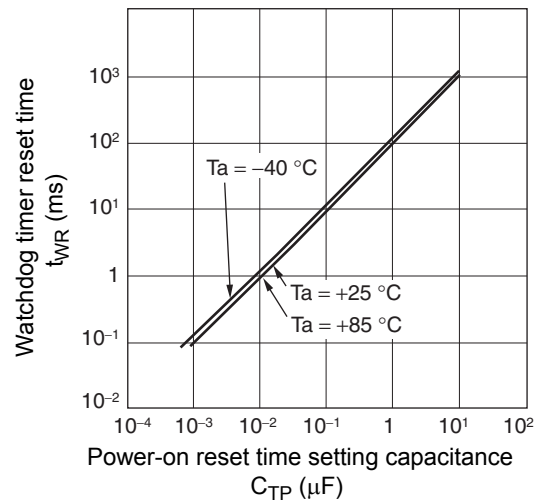

$t_{WD} - C_{TW}$ characteristics

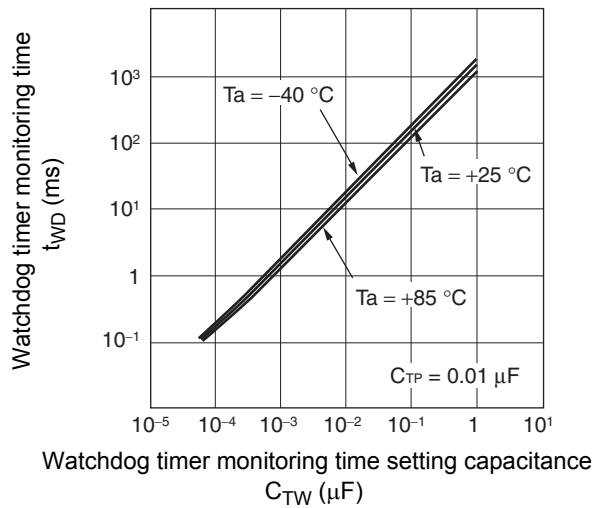

11. Application Example

11.1 Supply voltage monitor and watchdog timer

11.1.1 1-clock monitor

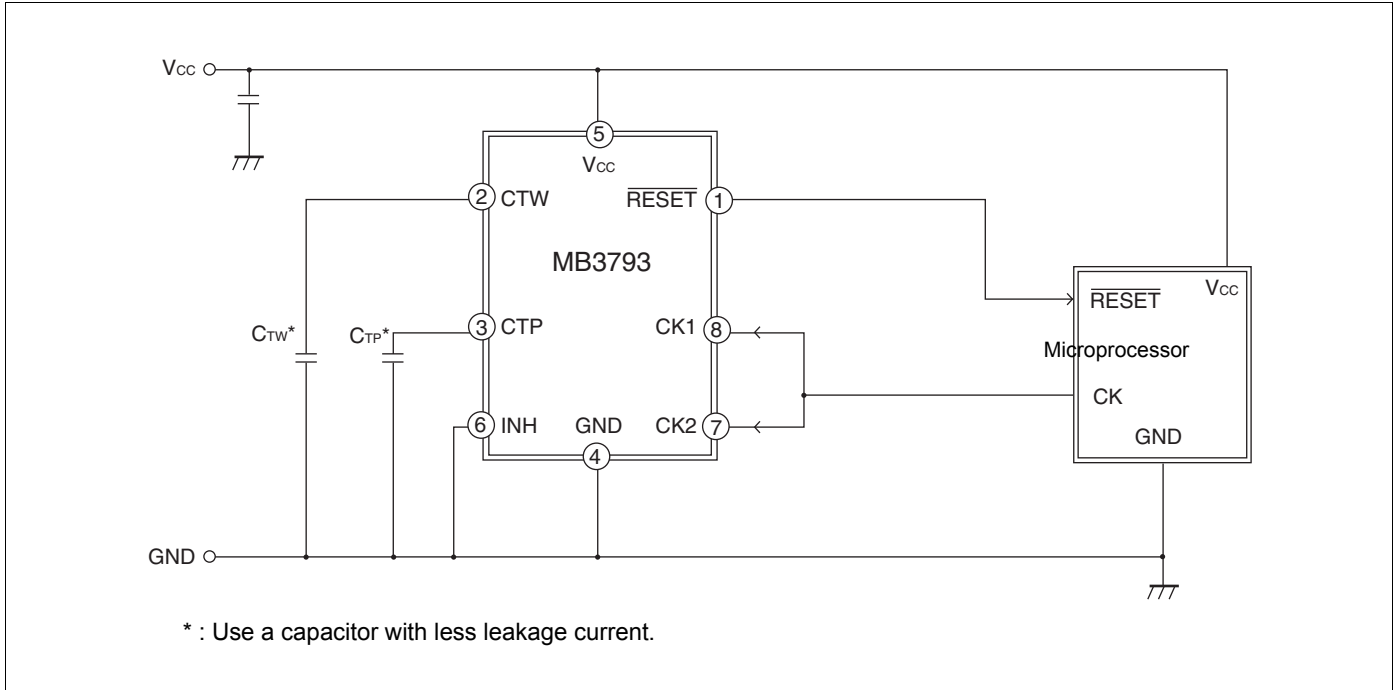

11.1.2 2-clock monitor

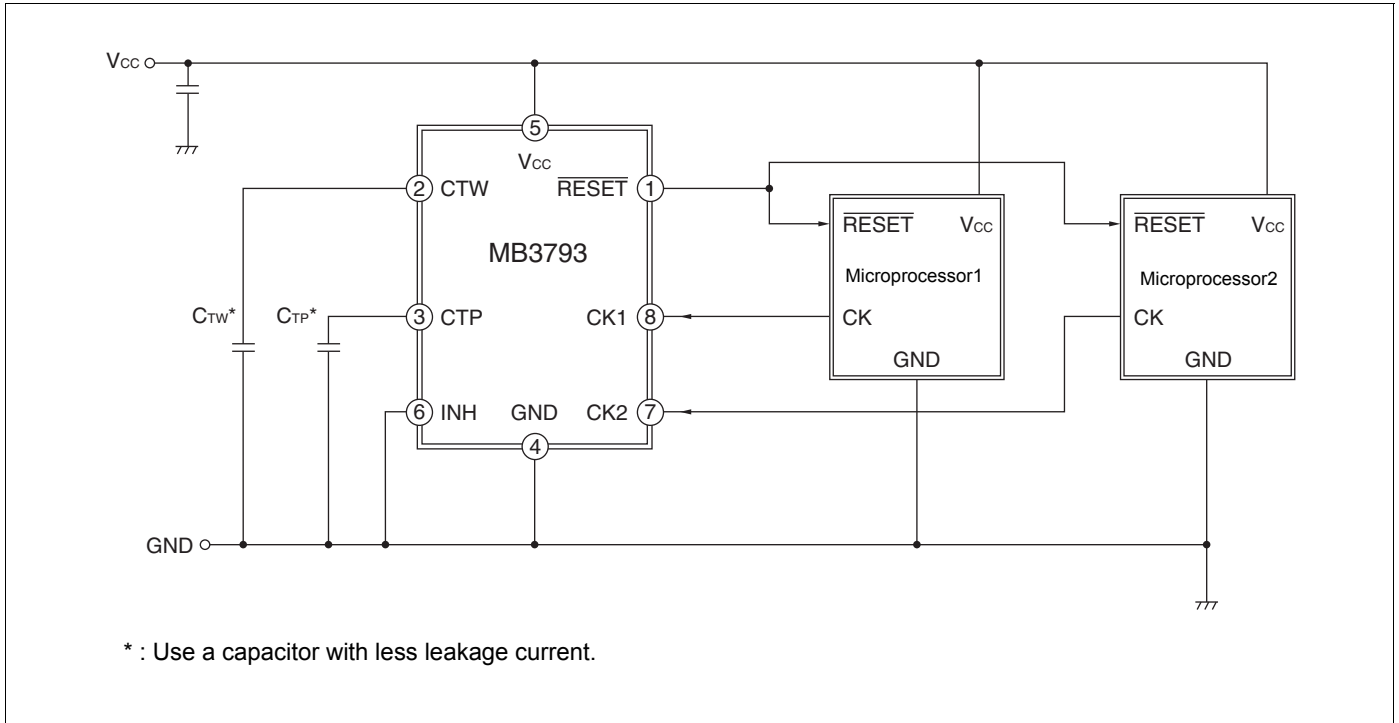

11.2 Supply voltage monitor and watchdog timer stop

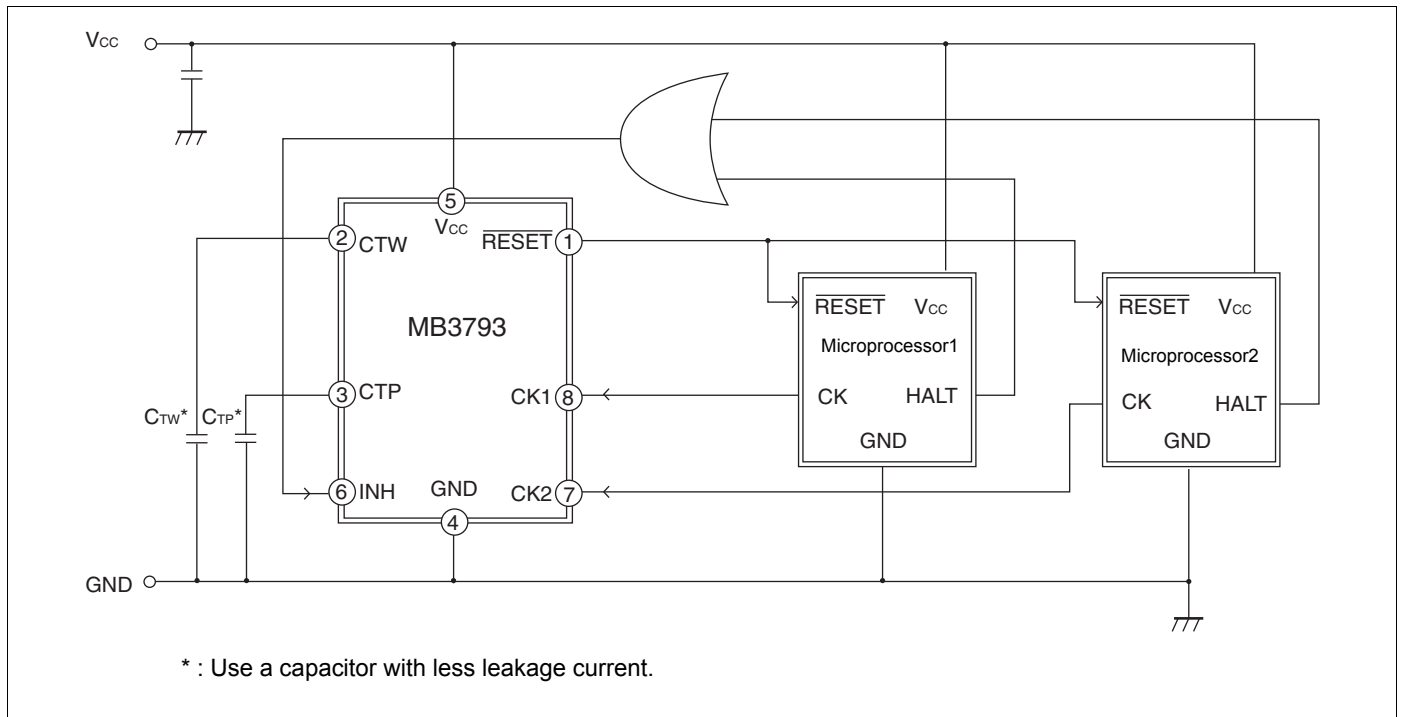

3. Setting of compulsory reset

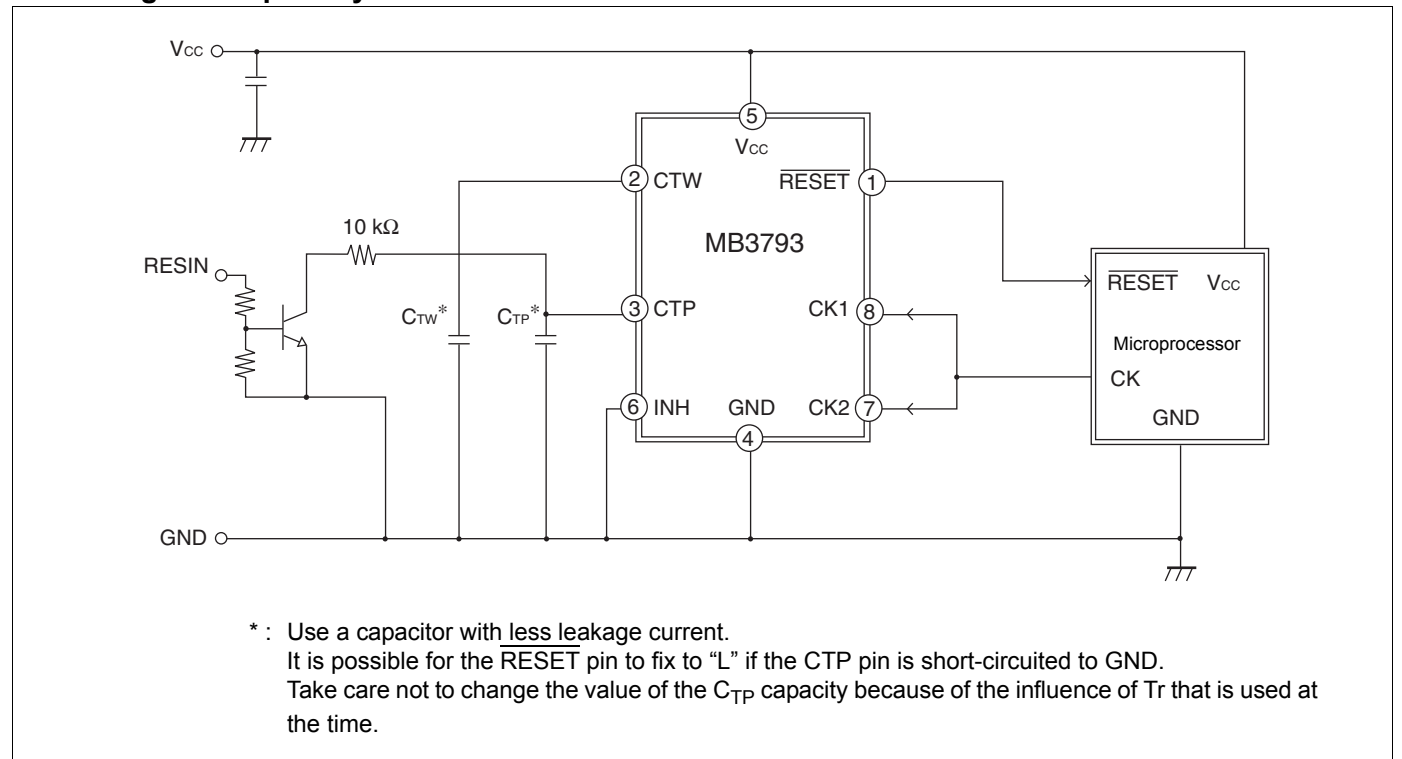

12. Usage Precaution

1. Do not configure the IC over the maximum ratings

If the IC is used over the maximum ratings, the LSI may be permanently damaged.

It is preferable for the device to normally operate within the recommended usage conditions. Usage outside of these conditions can have a bad effect on the reliability of the LSI.

2. Use the devices within recommended operating conditions

The recommended operating conditions are under which the LSI is guaranteed to operate.

The electrical ratings are guaranteed when the device is used within the recommended operating conditions and under the conditions stated for each item.

3. Printed circuit board ground lines should be set up with consideration for common impedance

4. Take appropriate measures against static electricity

- Containers for semiconductor materials should have anti-static protection or be made of conductive material.
- After mounting, printed circuit boards should be stored and shipped in conductive bags or containers.
- Work platforms, tools, and instruments should be properly grounded.
- Working personnel should be grounded with resistance of 250 kΩ to 1 MΩ between body and ground.

5. Do not apply negative voltages

The use of negative voltages below -0.3 V may create parasitic transistors on LSI lines, which can cause malfunctions.

13. Ordering Information

Part number	Package	Remarks
MB3793-34APNF	8-pin plastic SOP (FPT-8P-M02)	

14. RoHS Compliance Information of Lead (Pb) Free version

The LSI products of Cypress with “E1” are compliant with RoHS Directive , and has observed the standard of lead, cadmium, mercury, Hexavalent chromium, polybrominated biphenyls (PBB) , and polybrominated diphenyl ethers (PBDE).
The product that conforms to this standard is added “E1” at the end of the part number.

15. Labeling Sample (Lead free version)

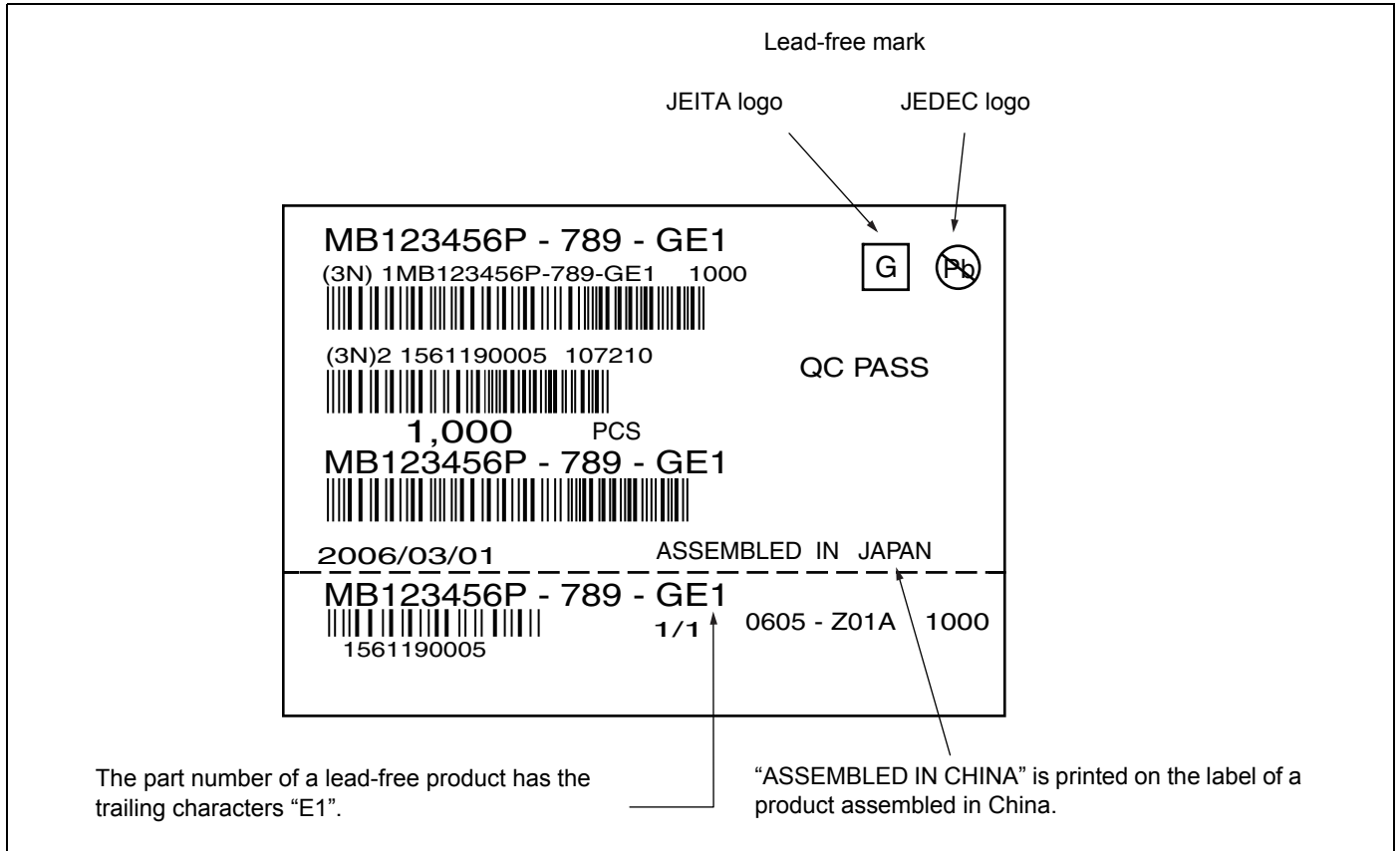

Lead-free mark

JEITA logo JEDEC logo

MB123456P - 789 - GE1
 (3N) 1MB123456P-789-GE1 1000

(3N)2 1561190005 107210

1,000 PCS

MB123456P - 789 - GE1

2006/03/01 ASSEMBLED IN JAPAN

MB123456P - 789 - GE1 0605 - Z01A 1000
 1561190005 1/1

The part number of a lead-free product has the trailing characters “E1”.

“ASSEMBLED IN CHINA” is printed on the label of a product assembled in China.

16. Marking Format (Lead Free version)

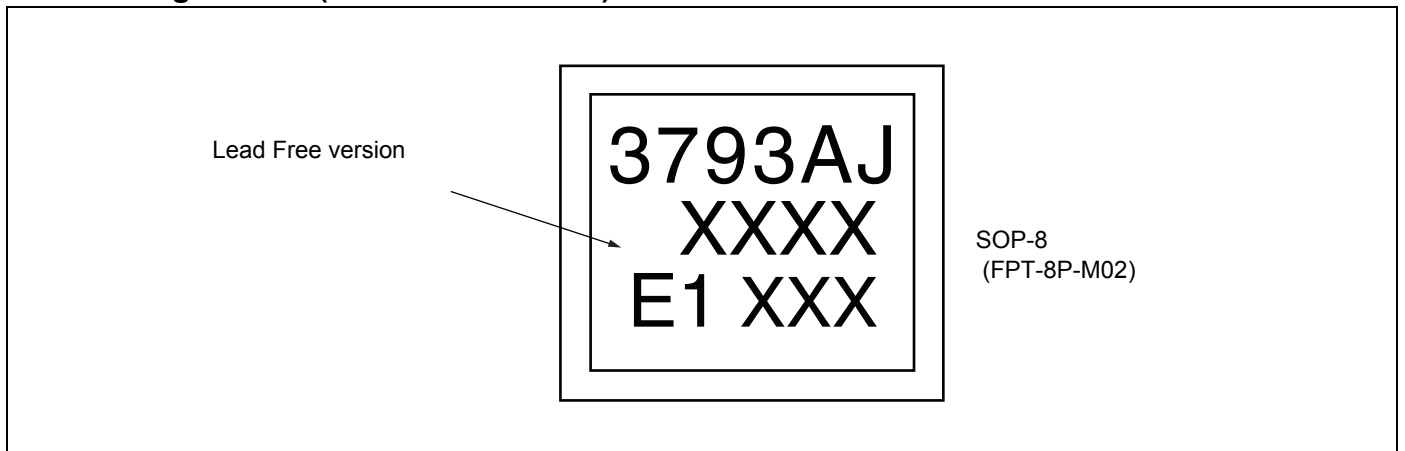

Lead Free version

3793AJ

XXXX

E1 XXX

SOP-8
(FPT-8P-M02)

17. MB3793-34APNF Recommended Conditions Of Moisture Sensitivity Level

Item	Condition	
Mounting Method	IR (infrared reflow) , Manual soldering (partial heating method)	
Mounting times	2 times	
Storage period	Before opening	Please use it within two years after Manufacture.
	From opening to the 2nd reflow	Less than 8 days
	When the storage period after opening was exceeded	Please processes within 8 days after baking (125°C, 24H)
Storage conditions	5°C to 30°C, 70%RH or less (the lowest possible humidity)	

[Temperature Profile for FJ Standard IR Reflow]

1. IR (infrared reflow)

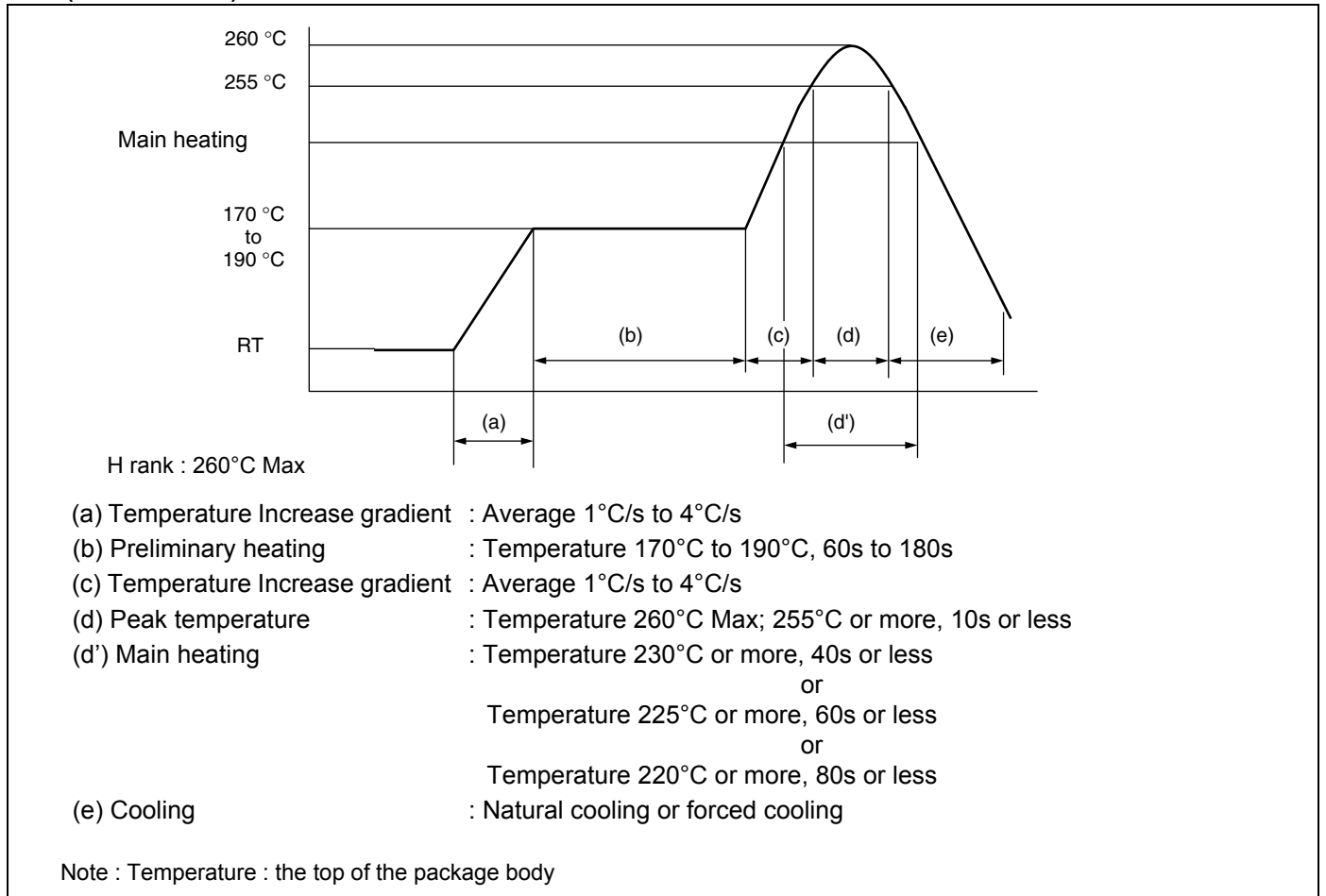

2. Manual soldering (partial heating method)

Conditions : Temperature 400°C Max
 Times : 5 s max/pin

18. Package Dimensions

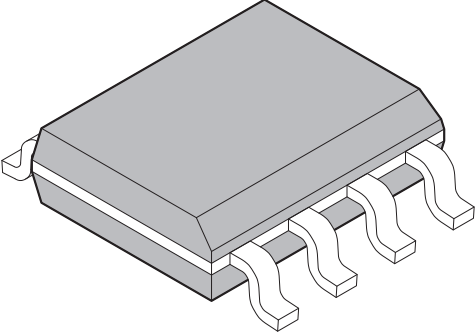
<p>8-pin plastic SOP</p>  <p>(FPT-8P-M02)</p>	Lead pitch	1.27 mm
	Package width × package length	3.9 × 5.05 mm
	Lead shape	Gullwing
	Sealing method	Plastic mold
	Mounting height	1.75 mm MAX
	Weight	0.06 g

8-pin plastic SOP (FPT-8P-M02)

Note 1) *1 : These dimensions include resin protrusion.
 Note 2) *2 : These dimensions do not include resin protrusion.
 Note 3) Pins width and pins thickness include plating thickness.
 Note 4) Pins width do not include tie bar cutting remainder.

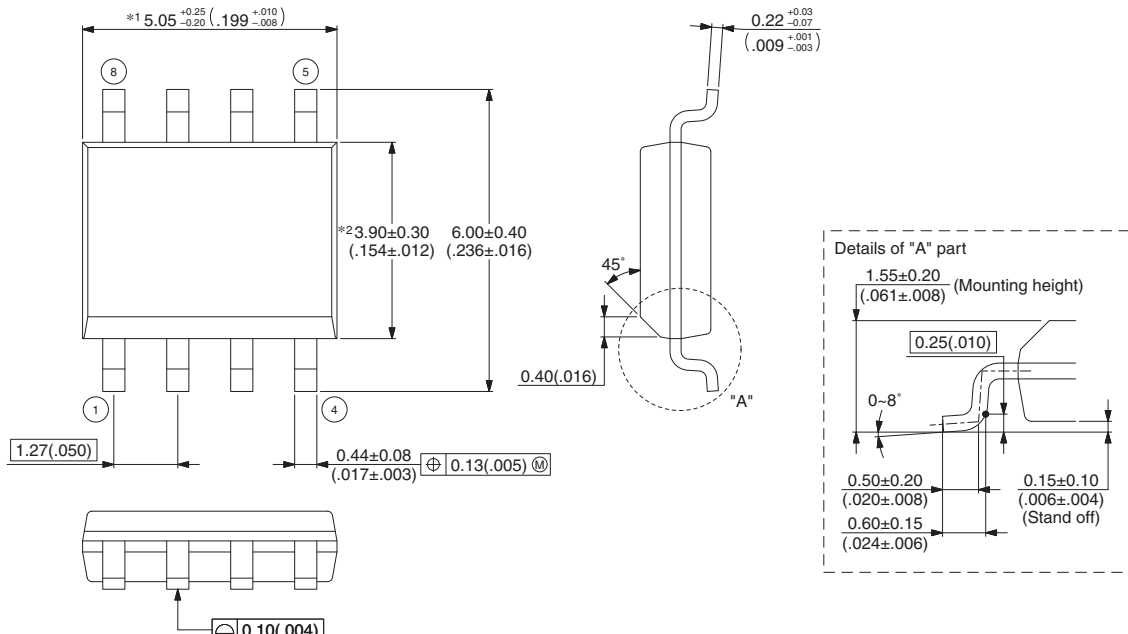

Dimensions in mm (inches).
 Note: The values in parentheses are reference values.

©2002-2008 FUJITSU MICROELECTRONICS LIMITED F08004S-c-4-8

Document History

Spansion Publication Number: DS04-27407-1E

Document Title: MB3793-34A Power-Voltage Monitoring IC with Watchdog Timer Document Number: 002-08556				
Revision	ECN	Orig. of Change	Submission Date	Description of Change
**	—	TAOA	11/30/2009	Migrated to Cypress and assigned document number 002-08556. No change to document contents or format.
*A	5199120	TAOA	03/31/2016	Updated to Cypress format.

Sales, Solutions, and Legal Information

Worldwide Sales and Design Support

Cypress maintains a worldwide network of offices, solution centers, manufacturer's representatives, and distributors. To find the office closest to you, visit us at [Cypress Locations](#).

Products

ARM® Cortex® Microcontrollers	cypress.com/arm
Automotive	cypress.com/automotive
Clocks & Buffers	cypress.com/clocks
Interface	cypress.com/interface
Lighting & Power Control	cypress.com/powerpsoc
Memory	cypress.com/memory
PSoC	cypress.com/psoc
Touch Sensing	cypress.com/touch
USB Controllers	cypress.com/usb
Wireless/RF	cypress.com/wireless

PSoC® Solutions

cypress.com/psoc
PSoC 1 | PSoC 3 | PSoC 4 | PSoC 5LP

Cypress Developer Community

[Community](#) | [Forums](#) | [Blogs](#) | [Video](#) | [Training](#)

Technical Support

cypress.com/support

© Cypress Semiconductor Corporation 2009-2016. This document is the property of Cypress Semiconductor Corporation and its subsidiaries, including Spansion LLC ("Cypress"). This document, including any software or firmware included or referenced in this document ("Software"), is owned by Cypress under the intellectual property laws and treaties of the United States and other countries worldwide. Cypress reserves all rights under such laws and treaties and does not, except as specifically stated in this paragraph, grant any license under its patents, copyrights, trademarks, or other intellectual property rights. If the Software is not accompanied by a license agreement and you do not otherwise have a written agreement with Cypress governing the use of the Software, then Cypress hereby grants you under its copyright rights in the Software, a personal, non-exclusive, nontransferable license (without the right to sublicense) (a) for Software provided in source code form, to modify and reproduce the Software solely for use with Cypress hardware products, only internally within your organization, and (b) to distribute the Software in binary code form externally to end users (either directly or indirectly through resellers and distributors), solely for use on Cypress hardware product units. Cypress also grants you a personal, non-exclusive, nontransferable, license (without the right to sublicense) under those claims of Cypress's patents that are infringed by the Software (as provided by Cypress, unmodified) to make, use, distribute, and import the Software solely to the minimum extent that is necessary for you to exercise your rights under the copyright license granted in the previous sentence. Any other use, reproduction, modification, translation, or compilation of the Software is prohibited.

CYPRESS MAKES NO WARRANTY OF ANY KIND, EXPRESS OR IMPLIED, WITH REGARD TO THIS DOCUMENT OR ANY SOFTWARE, INCLUDING, BUT NOT LIMITED TO, THE IMPLIED WARRANTIES OF MERCHANTABILITY AND FITNESS FOR A PARTICULAR PURPOSE. Cypress reserves the right to make changes to this document without further notice. Cypress does not assume any liability arising out of the application or use of any product or circuit described in this document. Any information provided in this document, including any sample design information or programming code, is provided only for reference purposes. It is the responsibility of the user of this document to properly design, program, and test the functionality and safety of any application made of this information and any resulting product. Cypress products are not designed, intended, or authorized for use as critical components in systems designed or intended for the operation of weapons, weapons systems, nuclear installations, life-support devices or systems, other medical devices or systems (including resuscitation equipment and surgical implants), pollution control or hazardous substances management, or other uses where the failure of the device or system could cause personal injury, death, or property damage ("Unintended Uses"). A critical component is any component of a device or system whose failure to perform can be reasonably expected to cause the failure of the device or system, or to affect its safety or effectiveness. Cypress is not liable, in whole or in part, and Company shall and hereby does release Cypress from any claim, damage, or other liability arising from or related to all Unintended Uses of Cypress products. Company shall indemnify and hold Cypress harmless from and against all claims, costs, damages, and other liabilities, including claims for personal injury or death, arising from or related to any Unintended Uses of Cypress products.

Cypress, the Cypress logo, Spansion, the Spansion logo, and combinations thereof, PSoC, CapSense, EZ-USB, F-RAM, and Traveo are trademarks or registered trademarks of Cypress in the United States and other countries. For a more complete list of Cypress trademarks, visit cypress.com. Other names and brands may be claimed as property of their respective owners.