

Bi-Directional, High Voltage, High Side Current Sense Amplifier

DESCRIPTION

Demonstration Circuit 1117 is a Bi-Directional, High Voltage, High Side Current Sense Amplifier featuring the LTC6104.

This demo board amplifies a current-sense resistor voltage-drop, and provides a precision bi-polar output voltage proportional to the bidirectional load current. The LTC6104 is implemented with dual input amplifier sections, one for each polarity of load current. The demo circuit includes scaling resistors that program the gain of each amplification polarity to 25V/V. Both input sections of the LTC6104 are powered from the same supply that the sense resistor is connected to and generates a bipolar signal referenced to a user furnished potential V_{REF} , such as 2.5V. The LTC6104 can perform bi-directional current measurements on supplies ranging from 4V to 60V.

Since the output voltage is developed as a bidirectionally-controlled current through a load resistance, ground-loop errors can be eliminated by simply locating the load resistor at the destination point (subsequent signal processing such as A/D conversion). Remote loading can be evaluated by simply removing the on board load resistor (R4).

The key performance characteristics of the LTC6104 and DC1117 are shown in the Performance Summary below.

Design files for this circuit board are available. Call the LTC factory.

LT, LT, Over-The-Top are registered trademarks of Linear Technology Corporation. Other product names may be trademarks of the companies that manufacture the products.

PERFORMANCE SUMMARY Specifications are at $T_A = 25^\circ\text{C}$

SYMBOL	PARAMETER	CONDITIONS	MIN	TYP	MAX	UNITS
V_{IN}	Monitored Supply Input Range		4	5...48	60	V
V_{MON}	Measurement Output Signal	$I_{OUTA} = 4A$		$V_{REF} + 2.0$		V
V_{MON}	Measurement Output Signal	$I_{OUTB} = -4A$		$V_{REF} - 2.0$		V
I_{MON}	Measurement Output Signal (current mode)	$I_{OUTA} = 4A, R4$ removed		400		μA
I_{MON}	Measurement Output Signal (current mode)	$I_{OUTB} = -4A, R4$ removed		-400		μA
I_{OUT}	Output Load Current Range	Thermal limit of R_{SENSE}			± 7	A
I_{INQ}	V_{IN} Quiescent Current	$V_{INA} = 12V, I_{OUTA} = 0A$		520		μA
t_R	V_{MON} step-response time	I_{OUT} step from 0A to $\pm 4A$		2		μs

OPERATING PRINCIPLES

The LTC6104 operates by amplifying the voltage drop on a sense resistor placed in series with the power source of a load to be monitored. The sense inputs of the amplifier differentially measure the sense-resistor drop to control internal variable current sources that allow translation of the input information to a level referenced to V_{REF} (externally furnished to this demo circuit, typically 2.5V). The LTC6104 uses two identical sense amplifier sections

along with a current mirror to form a bipolar output signal. The mirrored current from the B section transconductance stage provides the means to pull down on the output resistance, while the A section provides a pull up current. In DC1117 as shipped, the sense resistor installed is 20m Ω and the other resistors program the gain to 25V/V, so the nominal output scaling is 500mV per ampere of load current. Other scalings can be

LTC6104

realized by making resistor changes on the demo circuit. Bi-linear response (different scaling for each polarity) is also possible by using different input resistors for the A & B sense input sections.

The DC1117 Schematic diagram is shown in Figure 2.

QUICK START PROCEDURE

Demonstration circuit 1117 is easy to set up to evaluate the performance of the LTC6104. Refer to Figure 1 for proper measurement equipment setup and follow the procedure below:

1. With power off, connect a power supply positive to IN and the common to GND. This supply should be in the range of 4V to 60V. If this supply is not equipped with an accurate current readout, a DMM (set to measure Amperes) may be connected in series with the supply as shown in Figure 1.

NOTE. Be sure that the capacity of a current measuring DMM is adequate to handle the intended load current.

2. With power off, connect a reference voltage (2.5V for example) to REF and the common to GND. This supply must be capable of sourcing and sinking up to 1mA. This can be done with a normal lab power supply using a 1k Ω loading resistor to assure a unidirectional supply current in all conditions (this configuration is shown in Figure 1).

3. Connect a voltmeter or oscilloscope probe to the MON terminal, with the common connection or ground clip tied to GND. Alternatively, the measurement may be taken differentially between MON and REF to get a true bipolar readout (this is the DMM connection shown in Figure 1).
4. Connect a load to the OUTA terminal (positive) and return (negative) to the common of the power supply. The load may be a power resistor, active load instrument, battery pack, or other circuit of interest.
5. Turn on the power supply.
6. Measure an output voltage that corresponds to the load current. $V_{MON} = 0.4 \times I_{OUT} + V_{REF}$ for the factory installed resistors.

NOTE. I_{OUT} is positive for power flowing into the load. I_{OUT} is negative for power flow from the load (like if the load is a battery pack in discharge). This voltage will not include the REF potential in a differentially-connected output reading. To simulate a negative I_{OUT} with a simple resistive load, the IN and OUT connections of the DC1117 may be interchanged.

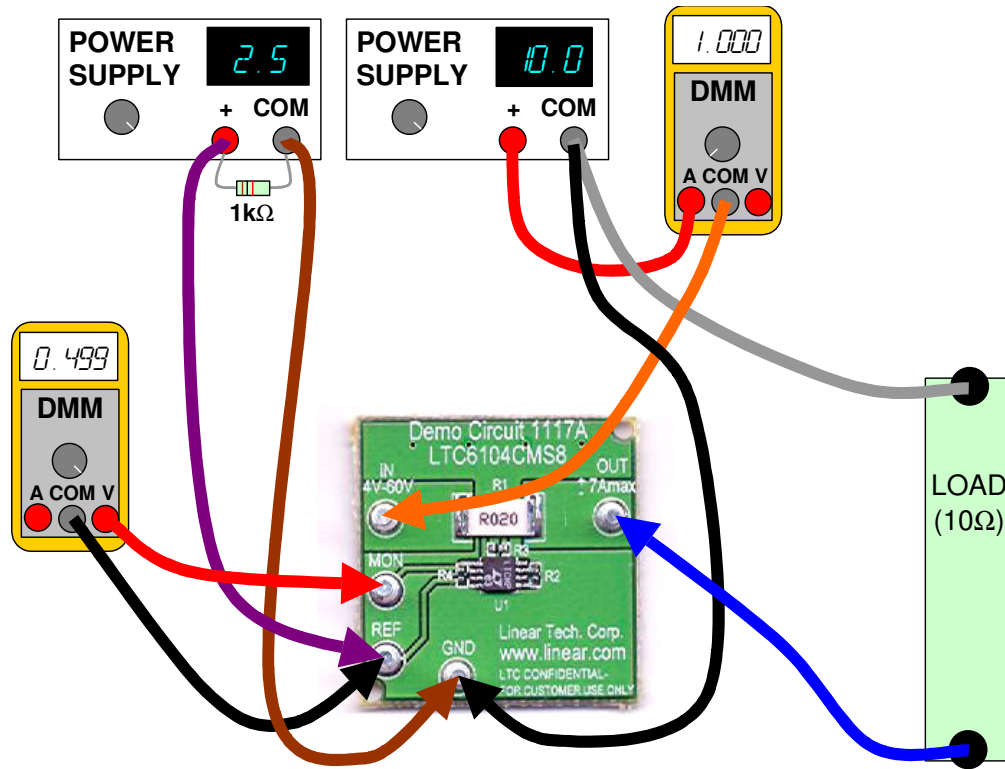

Figure 1. Proper Measurement Equipment Setup

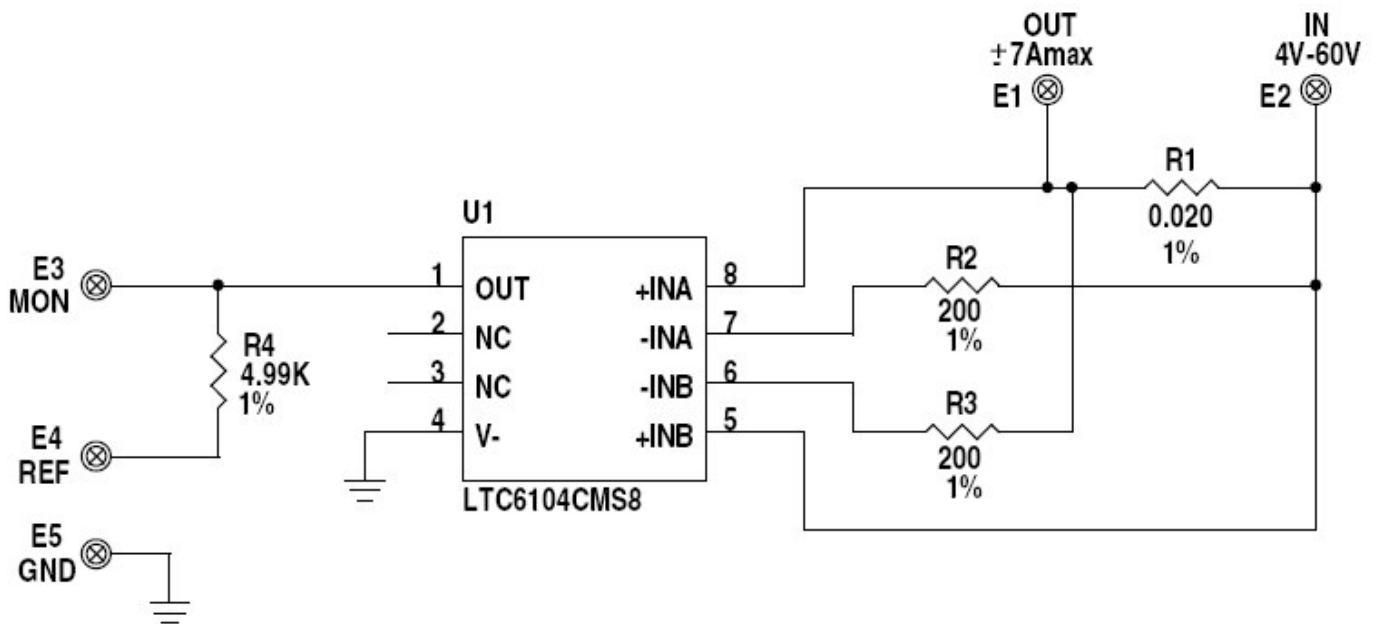

Figure 2. DC1117 Schematic Diagram