

S29WS064R

**64 Megabit (4M x 16-bit), CMOS 1.8 Volt-Only,
Simultaneous Read/Write, Multiplexed, Burst-Mode
MirrorBit® Flash Memory**



Supplement

This supplement contains information on the S29WS064R offerings for Industrial temperature range; -40°C to +85°C. Refer to the S29WS064R standard data sheet (Publication Number S29WS064R_00) for complete device specification.

General Description

The Spansion® S29WS064R is a burst-mode MirrorBit® flash product fabricated on 65 nm process technology. These products can operate up to 108 MHz using a V_{CC} range of 1.7V to 1.95V. when used in the Industrial temperature range, -40°C to +85°C.

1. Ordering Information for Industrial Temperature Range

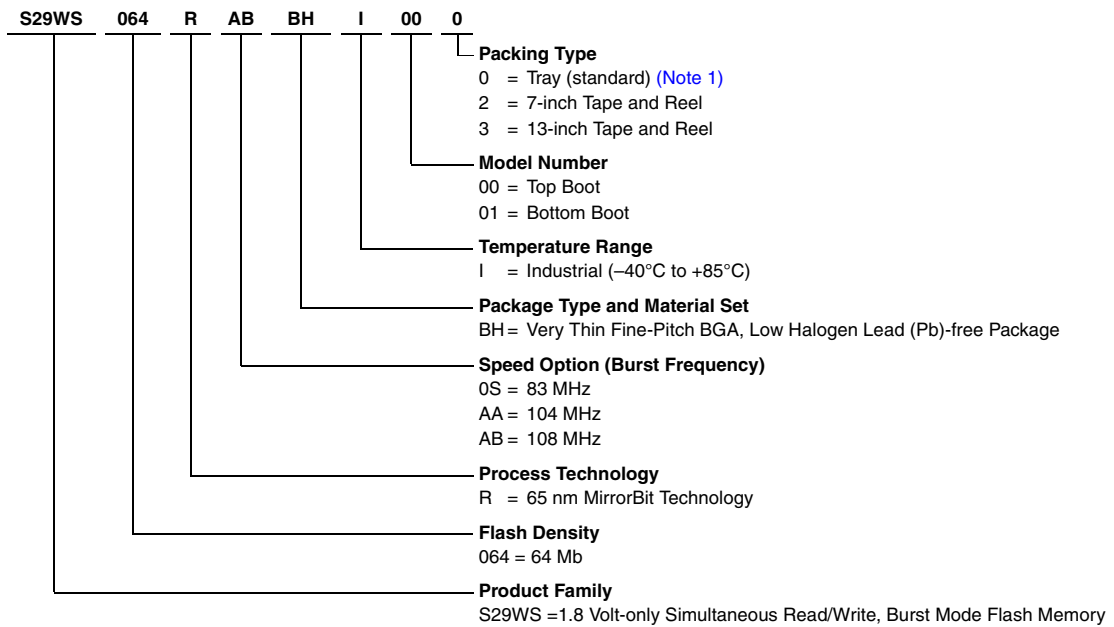

Valid Combinations

Valid Combinations list configurations planned to be supported in volume for this device. Consult your local sales office to confirm availability of specific valid combinations and to check on newly released combinations.

S29WS-R Valid Combinations Notes (1), (2)						
Base OPN	Speed Option	Package Type and Material	Temperature Range	Model Type	Packing Type	Package Type (Note 2)
S29WS064R	OS	BH	I	00	0	11.6 mm x 8 mm, 84-ball
	AA			01	2	
	AB				3	

Notes:

- Type 0 is standard. Specify other options as required.
- BGA package marking omits leading "S29" and packing type designator from ordering part number.

2. Industrial Temperature Range Specification Exceptions

There are a few specification differences for the industrial temperature range devices when compared to the wireless temperature range devices. The differences apply to operation of the device between -40°C to -26°C, and are described below.

2.1 Programming Performance

Parameter		Typ (Note 1)	Max (Note 2)	Unit	Comments
Single Word Program Time (using Program Buffer)	V _{CC}	170	1600	μs	Excludes system level overhead (Note 3)
Total 32-Word Buffer Programming Time	V _{CC}	450	6000		

Notes:

1. Typical program time assumes the following conditions: 25°C, 1.8V V_{CC}, 10,000 cycles. Additionally, programming typically assumes a checkerboard pattern.
2. Under worst case conditions of -40°C, V_{CC} = 1.70V, 100,000 cycles.
3. System-level overhead is the time required to execute the bus-cycle sequence for the program command. Refer to Table 12.1 of the S29WS064R standard data sheet (Publication Number S29WS064R_00) for further information on command definitions.

3. Revision History

Section	Description
Revision 01 (December 6, 2010)	
	Initial release.

Colophon

The products described in this document are designed, developed and manufactured as contemplated for general use, including without limitation, ordinary industrial use, general office use, personal use, and household use, but are not designed, developed and manufactured as contemplated (1) for any use that includes fatal risks or dangers that, unless extremely high safety is secured, could have a serious effect to the public, and could lead directly to death, personal injury, severe physical damage or other loss (i.e., nuclear reaction control in nuclear facility, aircraft flight control, air traffic control, mass transport control, medical life support system, missile launch control in weapon system), or (2) for any use where chance of failure is intolerable (i.e., submersible repeater and artificial satellite). Please note that Spansion will not be liable to you and/or any third party for any claims or damages arising in connection with above-mentioned uses of the products. Any semiconductor devices have an inherent chance of failure. You must protect against injury, damage or loss from such failures by incorporating safety design measures into your facility and equipment such as redundancy, fire protection, and prevention of over-current levels and other abnormal operating conditions. If any products described in this document represent goods or technologies subject to certain restrictions on export under the Foreign Exchange and Foreign Trade Law of Japan, the US Export Administration Regulations or the applicable laws of any other country, the prior authorization by the respective government entity will be required for export of those products.

Trademarks and Notice

The contents of this document are subject to change without notice. This document may contain information on a Spansion product under development by Spansion. Spansion reserves the right to change or discontinue work on any product without notice. The information in this document is provided as is without warranty or guarantee of any kind as to its accuracy, completeness, operability, fitness for particular purpose, merchantability, non-infringement of third-party rights, or any other warranty, express, implied, or statutory. Spansion assumes no liability for any damages of any kind arising out of the use of the information in this document.

Copyright © 2010 Spansion Inc. All rights reserved. Spansion®, the Spansion logo, MirrorBit®, MirrorBit® Eclipse™, ORNAND™, EcoRAM™ and combinations thereof, are trademarks and registered trademarks of Spansion LLC in the United States and other countries. Other names used are for informational purposes only and may be trademarks of their respective owners.