

PRODUCT OVERVIEW

The D1U54P-W-1200-12-HxxPC series are very high efficiency 1200 watt, power factor corrected front end supply with a 12V main output and a 5V or 3.3V (3A) standby. They have active current sharing and up to 8 supplies may be operated in parallel. The supply may be hot plugged; recovers from overtemperature faults, and has status LEDs on the front panel in addition to logic and PMBus™ status signals. The low profile 1U package and >28W/cubic inch power density make it ideal for delivering reliable, efficient power to servers, workstations, storage systems and other 12V distributed power systems



ORDERING GUIDE

Part Number	Power Output		Main Output	Standby Output	Airflow	IEC 320-C16 Input Connector Option
	200-240Vac	100-120Vac				
D1U54P-W-1200-12-HC4PC	1200W	1100W	12Vdc	3.3Vdc	Back to Front	HA4PTC ¹
D1U54P-W-1200-12-HA4PC				5Vdc		
D1U54P-W-1200-12-HC3PC				3.3Vdc	Front to Back	HA3PTC ¹
D1U54P-W-1200-12-HA3PC				5Vdc		

¹ Refer to Pg. 9 for [alternate input connector](#) (HAXPTC)

FEATURES

- 1200W output power
- 80 PLUS® Platinum efficiency
- 12V main output
- 3.3V and 5V standby output
- 1U height: 2.15" x 12.65" x 1.57"
- >28 Watts per cubic inch density
- N+1 redundancy capable, including hot plugging (up to 8 in parallel)
- Active current sharing on 12V main output; both outputs contain ORing FET isolation
- Overvoltage, overcurrent, overtemperature protection
- Internal cooling fan (variable speed)
- PMBus™ / I²C interface with status indicators
- RoHS compliant
- Two-year warranty

INPUT CHARACTERISTICS

Parameter	Conditions	Min.	Nom.	Max.	Units
Input Voltage Operating Range		90	115/230	264	Vac
Input Frequency		47	50/60	63	Hz
Turn-on Input Voltage	Ramp up	80	85	89	Vac
Turn-off Input Voltage	Ramp down	65	73	78	
Maximum current at Vin = 100Vac	1100W			12	Arms
Inrush Current	Cold start between 0 to 200msec			25	Apk
Power Factor	At 230Vac, full load		0.99		
Efficiency (230Vac) excluding fan load (HCxPC models 80 PLUS® certified)	20% load	90			%
	50% load	94			
	100% load	91			

OUTPUT VOLTAGE CHARACTERISTICS

Nominal Output Voltage	Parameter	Conditions	Min.	Typ.	Max.	Units
12V	Nominal Output Voltage			12		Vdc
	Output Set Point Accuracy	50% load; Tamb = 25°C	-0.5		+0.5	
	Line and Load Regulation		-1.0		+1.0	%
	Ripple Voltage & Noise ³	20MHz Bandwidth			150	mV p-p
	Output Current (230Vac)		5		100	A
	Output Current (120Vac)		5		90	A
	Load Capacitance		0		30,000	µF
3.3VSB	Nominal Output Voltage			3.3		Vdc
	Line and Load Regulation		3.14		3.46	
	Ripple Voltage & Noise ³	20MHz Bandwidth			75	mV p-p
	Output Current		0		3	A
5VSB	Load Capacitance		0		1000	µF
	Nominal Output Voltage			5.0		Vdc
	Line and Load Regulation		4.76		5.24	
	Ripple Voltage & Noise ¹²	20MHz Bandwidth			75	mV p-p
	Output Current		0		3	A
	Load Capacitance		0		1000	µF

³ Ripple and noise are measured with 0.1 µF of ceramic capacitance and 10 µF of tantalum capacitance on each of the power supply outputs. A short coaxial cable with 50Ω scope termination is used.



Available now at:
www.murata-ps.com/en/3d/acdc.html



OUTPUT CHARACTERISTICS					
Parameter	Conditions	Min.	Typ.	Max.	Units
Startup Time	AC ramp up			3	s
Transient Response	12V, 50% load step, 1A/μs di/dt			±5	%
	VSB, 50% load step, 1A/μs di/dt			±5	
Current sharing accuracy (up to 8 in parallel) ¹	At 100% load			±7	%
Hot Swap Transients	All outputs remain in regulation			5	%
Holdup Time	Full AC input range and 1200W total output power	12			ms
	Full AC input range and 720W total output power	20			ms

ENVIRONMENTAL CHARACTERISTICS					
Parameter	Conditions	Min.	Typ.	Max.	Units
Storage Temperature Range		-40		70	°C
Operating Temperature Range		0		60	
Operating Humidity	Noncondensing	5		90	%
Storage Humidity		5		95	
Altitude (without derating at 40°C)		3000			m
Shock	30G non-operating				
Operational Vibration	Sine sweep; 5-150Hz, 2G; random vibration, 5-500Hz, 1.11G				
MTBF	Per Telcordia SR-332 M1C1 @40°C	529K			hrs
Safety Approval Standards	CAN/CSA C22.2 No 60950-1-07, Amendment 1:2011, Amendment 2:2014 (MOD) ANSI/UL 60950-1-2014 IEC60950-1:2005 (2nd ED.)+A1:2009+A2:2013 EN60950-1:2006+A11+A1+A12+A2 CCC GB4943.1-2011, GB9254-2008, GB17625. 1-2012 BSMI CNS14336-1; CNS13438				
Input Fuse	Power Supply has internal 15A/250V fast blow fuse on the AC line input				
Weight	2.43 lbs (1.10 kg)				

PROTECTION CHARACTERISTICS						
Output Voltage	Parameter	Conditions	Min.	Typ.	Max.	Units
12V	Overtemperature (intake)	Autorestart	70		80	°C
	Overvoltage	Latching	13		14	V
	Overcurrent At 220Vac	Hiccup	105		120	A
	Overcurrent At 110Vac ⁴	Hiccup	99		117	A
3.3VSB	Overvoltage	Latching	3.6		4.0	V
	Overcurrent	Hiccup	3.3		4.5	A
5VSB	Overvoltage	Latching	5.4		6.0	V
	Overcurrent	Hiccup	3.3		4.5	A

⁴An output overload condition that caused the input current to exceed 13Aac shall initiate a latching shutdown. It will be necessary to recycle the ac input source in order to clear the latched condition.

ISOLATION CHARACTERISTICS					
Parameter	Conditions	Min.	Typ.	Max.	Units
Insulation Safety Rating / Test Voltage	Input to Output - Reinforced	3000			Vrms
	Input to Chassis - Basic	1500			Vrms
Isolation	Output to Chassis	500			Vdc

STATUS INDICATORS AND CONTROL SIGNALS	GREEN	AMBER
Condition	LED Status (Power)	LED Status (Fault)
Standby - ON; Main output - OFF; AC PRESENT	Blinking green	Off
Standby - ON; Main output - ON	Solid green	Off
Main output overcurrent, undervoltage, overvoltage	Off	On
FAN_FAULT; overtemperature; standby overcurrent, undervoltage	Off	On
No AC Power	Off	Off
Power Supply Warning Event	Off	Blinking

STATUS AND CONTROL SIGNALS			
Signal Name	I/O	Description	Interface Details
ACOK (AC Source)	Output	The signal output is driven high when input source is available and within acceptable limits. The output is driven low to indicate loss of input power.	Pulled up internally via 10K to VDD ⁴ A logic high >2.0Vdc A logic low <0.8Vdc Driven low by internal CMOS buffer (open drain output).
PWOK (Output OK)	Output	The signal is asserted, driven high, by the power supply to indicate that all outputs are valid. If any of the outputs fail then this output will be hi-Z or driven low. The output is driven low to indicate that the Main output is outside of lower limit of regulation (11.4Vdc).	Pulled up internally via 10K to VDD ⁴ A logic high >2.0Vdc A logic low <0.8Vdc Driven low by internal CMOS buffer (open drain output).
SMB_ALERT (FAULT/ WARNING)	Output	The signal output is driven low to indicate that the power supply has detected a warning or fault and is intended to alert the system. This output must be driven high when the power is operating correctly (within specified limits). The signal will revert to a high level when the warning/fault stimulus (that caused the alert) is removed.	Pulled up internally via 10K to VDD ⁴ A logic high >2.0Vdc A logic low <0.8Vdc Driven low by internal CMOS buffer (open drain output).
PRESENT_L (Power Supply Absent)	Output	The signal is used to detect the presence (installed) of a PSU by the host system. The signal is connected to PSU logic SGND within the power module.	Passive connection to +VSB_Return. A logic low <0.8Vdc
PS_ON (Power Supply Enable/Disable)	Input	This signal is pulled up internally to the internal housekeeping supply (within the power supply). The power supply main 12Vdc output will be enabled when this signal is pulled low to +VSB_Return. In the low state the signal input shall not source more than 1mA of current. The 12Vdc output will be disabled when the input is driven higher than 2.4V, or open circuited. Cycling this signal shall clear latched fault conditions.	Pulled up internally via 10K to VDD ⁴
PSKILL	Input	This signal is used during hot swap to disable the main output during hot swap extraction. The input is pulled up internally to the internal housekeeping supply (within the power supply). The signal is provided on a short (lagging pin) and should be connected to +VSB_Return.	A logic high >2.0Vdc
APS (Address Select)	Input	An analog input that is used to set the address of the internal slave devices (EEPROM and microprocessor) used for digital communications. Connection of a suitable resistor, to +VSB_Return, in conjunction with an internal resistor divider chain, will configure the required address.	DC voltage between the limits of 0 and VDD ⁴
SCL (Serial Clock)	Both	A serial clock line compatible with PMBus™ Power Systems Management Protocol Part 1 – General Requirements Rev 1.1. No additional internal capacitance is added that would affect the speed of the bus. The signal is provided with a series isolator device to disconnect the internal power supply bus in the event that the power module is unpowered.	VIL is 0.8V maximum VOL is 0.4V maximum when sinking 3mA VIH is 2.1V minimum
SDA (Serial Data)	Both	A serial data line compatible with PMBus™ Power Systems Management Protocol Part 1 – General Requirements Rev 1.1. The signal is provided with a series isolator device to disconnect the internal power supply bus in the event that the power module is unpowered.	VIL is 0.8V maximum VOL is 0.4V maximum when sinking 3mA VIH is 2.1V minimum

⁴VDD is an internal voltage rail derived from VSB and an internal housekeeping rail (“diode ORed” together) and is compatible with the voltage tolerances of VSB).

STATUS AND CONTROL SIGNALS CONTINUED

V1_SENSE V1SENSE_RTN	Input	Remote sense connections intended to be connected at and sense the voltage at the point of load. The voltage sense will interact with the internal module regulation loop to compensate for voltage drops due to connection resistance between the output connector and the load. If remote sense compensation is not required then the voltage can be configured for local sense by: V1_SENSE directly connected to power blades 6 to 10 (inclusive) V1_SENSE_RTN directly connected to power blades 1 to 5 (inclusive)	Compensation for up to 0.12Vdc total connection drop (output and return connections).
ISHARE	Bi-Directional Analogue Bus	The current sharing signal is connected between sharing units (forming an ISHARE bus). It is an input and/or an output (bi-directional analog bus) as the voltage on the line controls the current share between sharing units. A power supply will respond to a change in this voltage but a power supply can also change the voltage depending on the load drawn from it. On a single unit the voltage on the pin (and the common ISHARE bus would read approximately 8VDC at 100% load (module capability). For two identical units sharing the same 100% load this would read approximately 4VDC for perfect current sharing (i.e. 50% module load capability per unit).	Analogue voltage: +8V maximum; 4K to +12V_RTN

TIMING SPECIFICATIONS

Turn-On Delay & Output Rise Time:

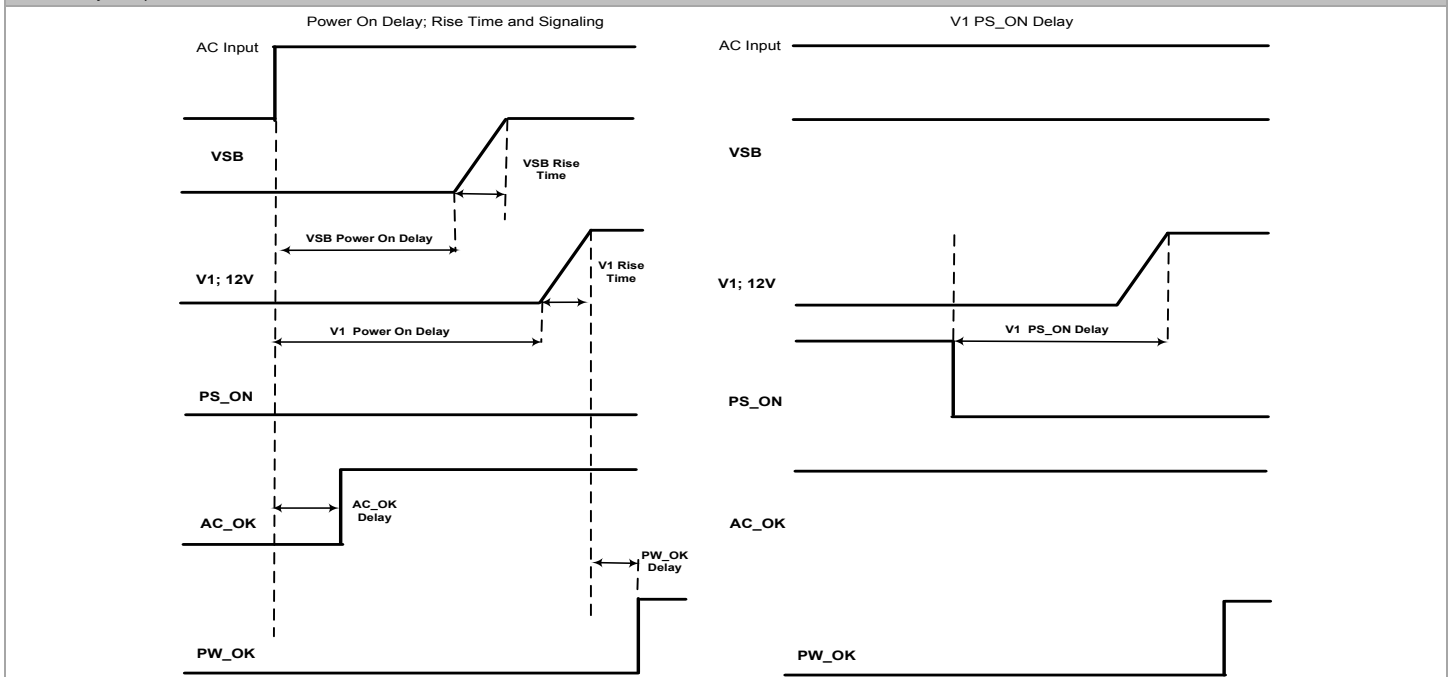

1. The turn-on delay after application of AC input within the operating range shall as defined in the following tables.
2. The output rise times shall be measured from 10% of the nominal output to the lower limit of the regulation band as defined in the following tables.

Time	Min	Max
Vsb Power-on-delay		2700ms
Vsb Rise time	40ms	100mS
V1 Rise time	2ms	10ms
V1 Power-on-delay		3000ms
V1 PS_ON delay	2ms	20ms
V1 PWOK delay	100ms	300ms
ACOK detect	500ms	2500ms

TIMING SPECIFICATIONS

Turn-Off (Shutdown by PS_ON)

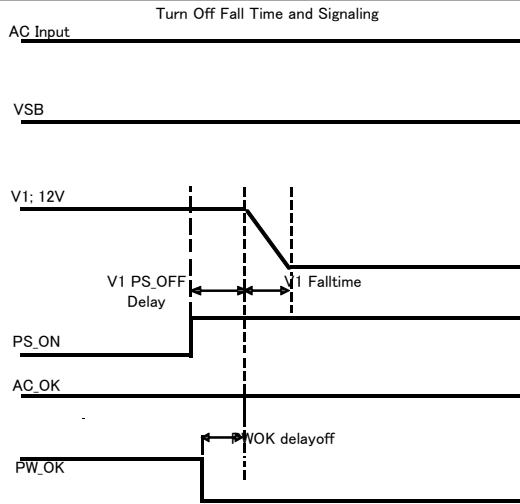

Turn-Off Timing	Min	Max	Notes
V1 Fall time	-	-	Must be monotonic
V1 PS_OFF delay	0ms	5ms	
PW_OK delay off	1.0ms		

1. Note this characteristic is applicable for the main 12Vdc output shutdown from PS_ON pulled high.

Power Removal Holdup

Power removed holdup falltime and signaling

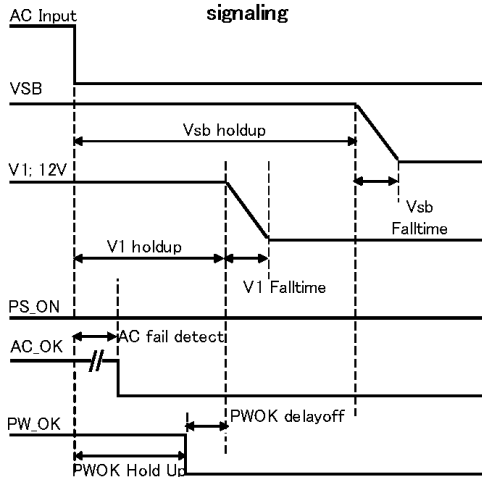

Power Removal Timing	Min	Max	Notes
Vsb holdup	40ms	-	
V1 holdup (Effective Total)	12ms	-	100% load
AC fail detect	-	40ms	
PWOK delay off	1.0ms		100% load
PWOK Hold Up	11.0ms		100% load

EMISSIONS AND IMMUNITY

Characteristic	Standard	Compliance
Input Current Harmonics	IEC/EN 61000-3-2	Complies
Voltage Fluctuation and Flicker	IEC/EN 61000-3-3	Complies
Conducted Emissions	FCC 47 CFR Part 15/CISPR 22/EN55022	Class A with 6dB margin
ESD Immunity	IEC/EN 61000-4-2	Level 4 criteria A
Radiated Field Immunity	IEC/EN 61000-4-3	Level 3 criteria B
Electrical Fast Transients/Burst	IEC/EN 61000-4-4	Level 3 criteria B
Surge Immunity	IEC/EN 61000-4-5	Level 3 criteria A
RF Conducted Immunity	IEC/EN 61000-4-6	Level 3 criteria A
Magnetic Field Immunity	IEC/EN 61000-4-8	3 A/m criteria B
Voltage Dips, Interruptions	IEC/EN 61000-4-11	230V _{in} , 100% load, Phase 0°, Dip 100% Duration 10ms (A) 230V _{in} , 50% load, Phase 0°, Dip 100% Duration 20ms (VSB:A, V1:B) 230V _{in} , 100% load, Phase 0°, Dip 100% Duration > 20ms (VSB, V1:B)

DERATING CURVES

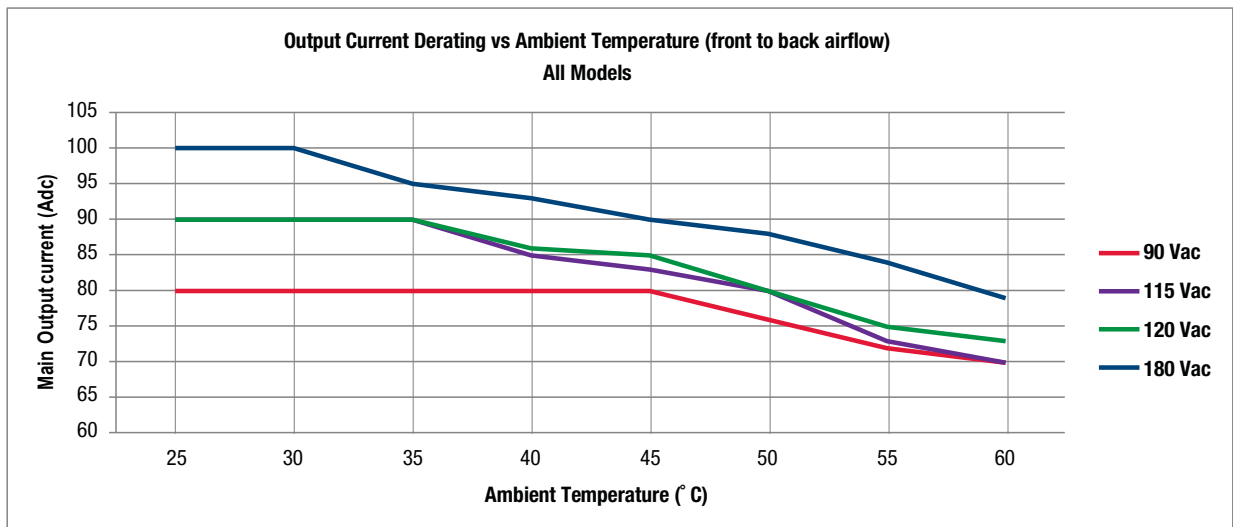
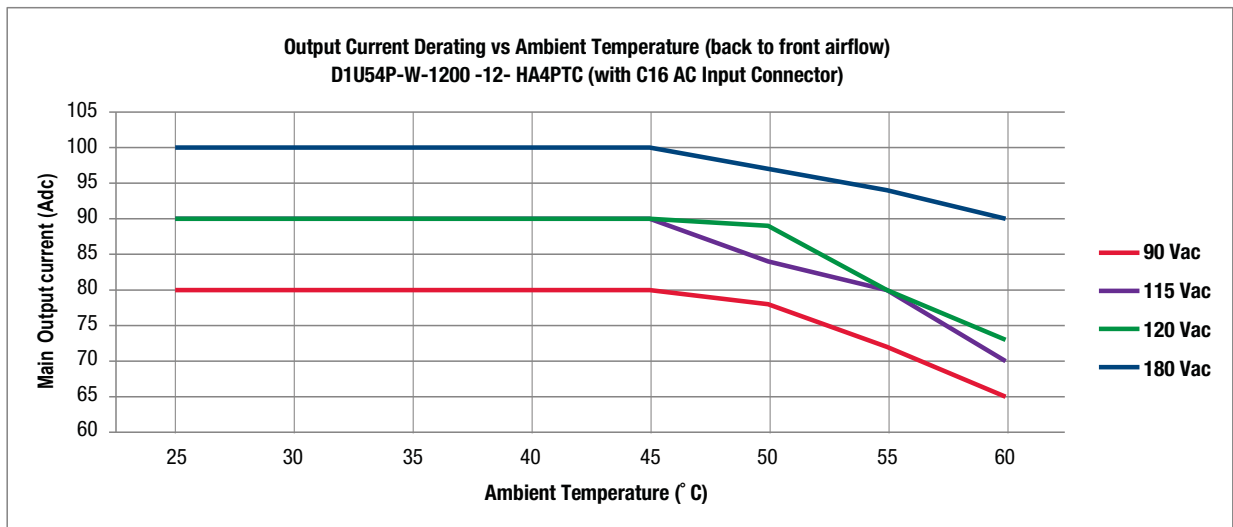
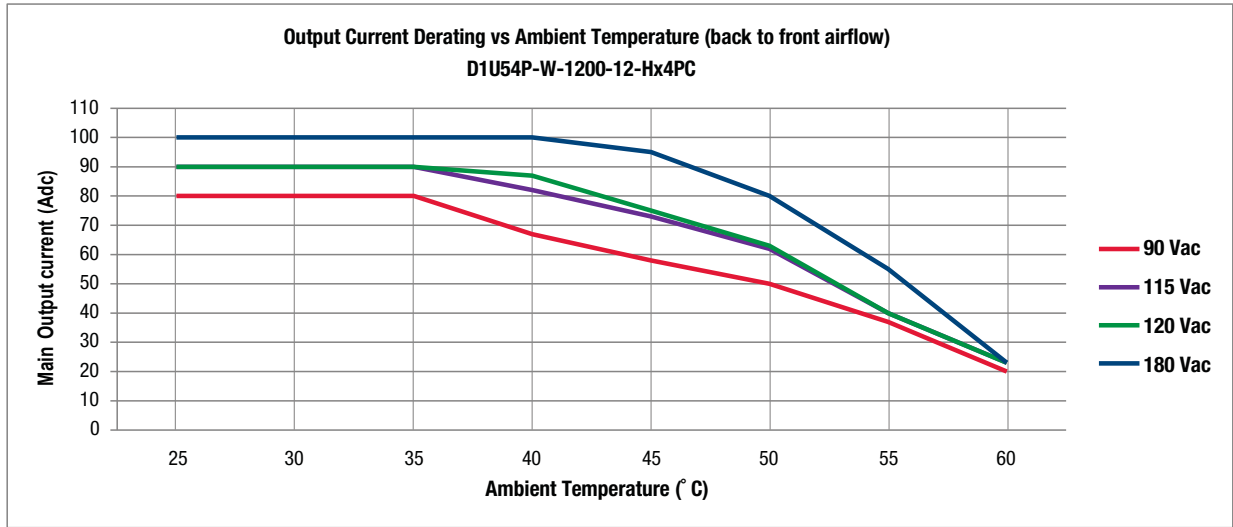

OUTPUT CONNECTOR AND SIGNAL SPECIFICATION

E1	E2	E3	E4	E5	1	2	3	4	5	6	7	8	9	10
D1	D2	D3	D4	D5										
C1	C2	C3	C4	C5										
B1	B2	B3	B4	B5										
A1	A2	A3	A4	A5										

PIN ASSIGNMENTS - D1U54P-W-1200-12-HxxPC

Tyco PN 1926734-2 (Power Supply)

Pin	Signal Name	Comments
6, 7, 8, 9, 10	V1	+ 12V main output
1, 2, 3, 4, 5	PGND	+ 12V main output return
A1	VSB	Standby output
B1	VSB	Standby output
C1	VSB	Standby output
D1	VSB	Standby output
E1	VSB	Standby output
A2	VSB_return	Standby return
B2	VSB_return	Standby return
C2	unused	
D2	unused	
E2	unused	
A3	APS	I2C address and protocol selection, (select by a pull down resistor)
B3	unused	
C3	SDA	I2C data signal line
D3	V1_SENSE_R	- Remote Sense return
E3	V1_SENSE	+ Remote Sense
A4	SCL	I2C clock signal line
B4	PS_ON	Remote On/Off
C4	SMB_ALERT	I2C alert signal
D4	unused	
E4	ACOK	AC input OK
A5	PSKILL	Power supply kill, short pin
B5	ISHARE	Current share bus, short pin
C5	PWOK	Power OK, short pin
D5	unused	
E5	PRESENT_L	Power supply present, short pin

MATING CONNECTOR

Part Number	Description
Tyco Electronics 2-1926739-5	Right Angle

WIRING DIAGRAM FOR OUTPUT

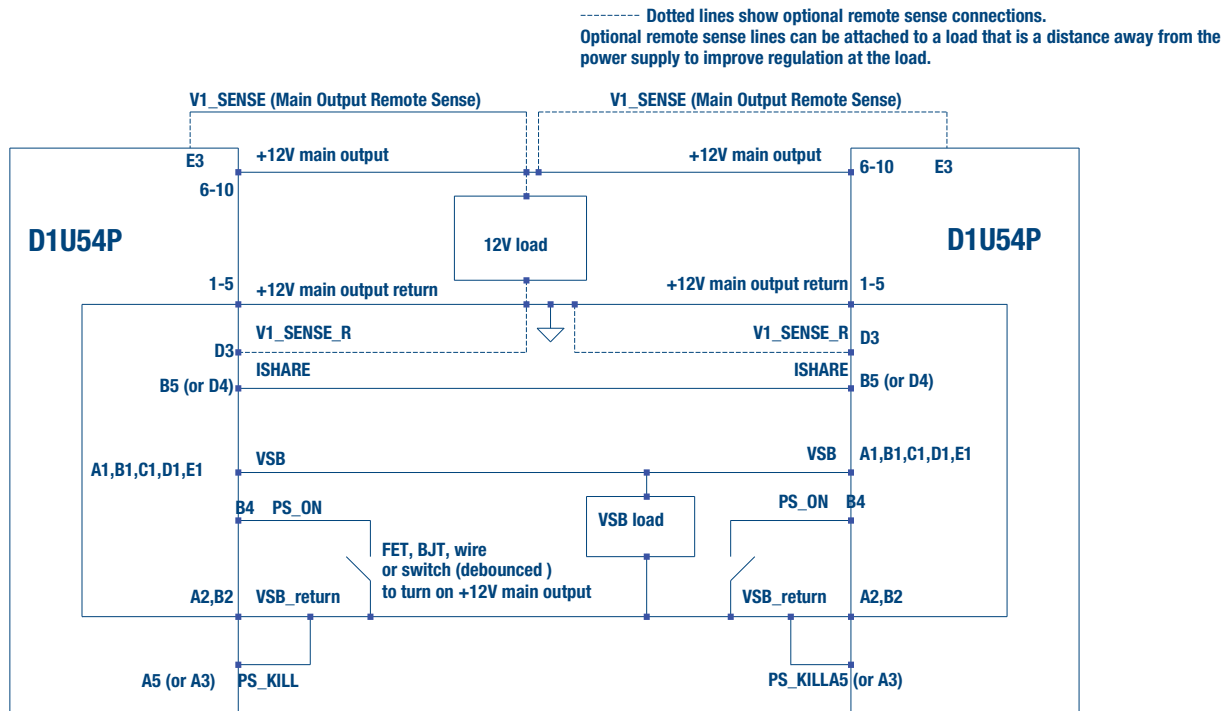

CURRENT SHARING NOTES

1. Main Output current sharing is achieved using the active current share method. (See wiring diagram for connection details.) Current sharing can be achieved with or without remote sense connected to the common load.
2. +VSB outputs can be tied together for redundancy but total combined output power must not exceed the rated standby power. The +VSB output has internal ORing MOSFET for additional redundancy / internal short protection.
3. The current share pin B5 (or D4 for alternate pin out model) is a connection between the units. It is input and/or output as the voltage on the line controls the current share. A power supply will respond to a change in this voltage but a power supply can also change the voltage depending on the load drawn from it. On a single unit this would read approximately 8V at 100% load. For two units sharing load then this should read approximately 4V for perfect current sharing.
4. Up to 8 units can be paralleled together. Please consult your Murata sales representative if operation with more than 8 units in parallel is needed.
5. The load for both the main 12V and the VSB rails at initial startup shall not be allowed to exceed the capability of a single unit. The load can be increased after a delay of 3sec (minimum), to allow all sharing units to achieve steady state regulation.

MECHANICAL DIMENSIONS

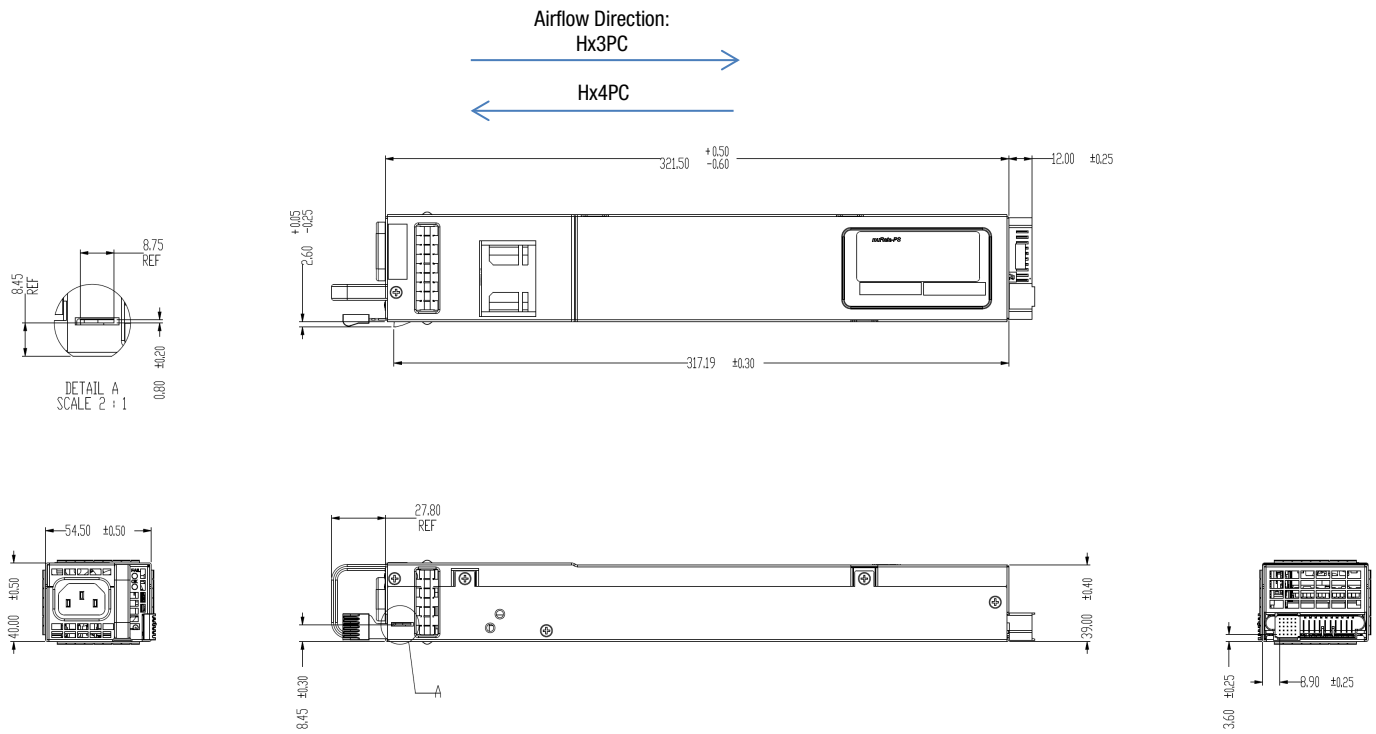

AC input connector: IEC 320-C14

Alternate input connector: IEC 320-C16 (for HAXPTC models); Link back to [front page](#)

Dimensions: 2.15" x 12.657" x 1.575" [54.5mm x 322.0mm x 40.0mm]

Reference file: I:\Eng_wip\UserPDDwg\1728\D1U54P-1200 dated 9/21/2018

Latch: 1) when latch is not pressed, Latch front edge below PSU body surface.

2) Latch can fully go inside PSU body surface when handle is pressed down.

OPTIONAL ACCESSORIES

Description	Part Number
12V D1U54P Output Connector Card	D1U54P-12-CONC

APPLICATION NOTES

Document Number	Description	Link
ACAN-44	D1U54P Output Connector Card	www.murata-ps.com/data/apnotes/acan-44.pdf
ACAN-45	D1U54P-x Communication Protocol	www.murata-ps.com/data/apnotes/acan-45.pdf

Murata Power Solutions, Inc.
129 Flanders Rd. Westborough, Ma 01581, USA.
ISO 9001 and 14001 REGISTERED



This product is subject to the following operating requirements and the Life and Safety Critical Application Sales Policy:

Refer to: <http://www.murata-ps.com/requirements/>

Murata Power Solutions, Inc. makes no representation that the use of its products in the circuits described herein, or the use of other technical information contained herein, will not infringe upon existing or future patent rights. The descriptions contained herein do not imply the granting of licenses to make, use, or sell equipment constructed in accordance therewith. Specifications are subject to change without notice.
© 2018 Murata Power Solutions, Inc.