

FEATURES

Attenuation range: 0.5 dB LSB steps to 31.5 dB

Low insertion loss

1.1 dB at 1 GHz

1.3 dB at 2 GHz

Typical step error: less than ± 0.1 dB

Excellent attenuation accuracy

Safe state transitions

High linearity

Input 0.1 dB compression (P0.1dB): 30 dBm typical

Input third-order intercept (IP3): 55 dBm typical

RF settling time (0.05 dB final RF output): 250 ns

Low phase shift error: 6° at 1 GHz

Single supply operation: 3.3 V to 5 V

ESD rating: Class 2 (2 kV HBM)

24-lead, 4 mm \times 4 mm LFCSP package: 16 mm²

Pin compatible to the [HMC624A](#)

APPLICATIONS

Cellular infrastructure

Microwave radios and very small aperture terminals (VSATs)

Test equipment and sensors

IF and RF designs

GENERAL DESCRIPTION

The [HMC1122](#) is a 6-bit digital attenuator operating from 0.1 GHz to 6 GHz with a 31.5 dB attenuation control range in 0.5 dB steps.

The [HMC1122](#) is implemented in a silicon process, offering very fast settling time, low power consumption, and high ESD robustness. The device features safe state transitions and optimized for excellent step accuracy and high linearity over frequency and temperature range. The RF input and output are internally matched to 50 Ω and do not require any external matching components. The design is bidirectional; therefore, the RF input and output are interchangeable.

FUNCTIONAL BLOCK DIAGRAM

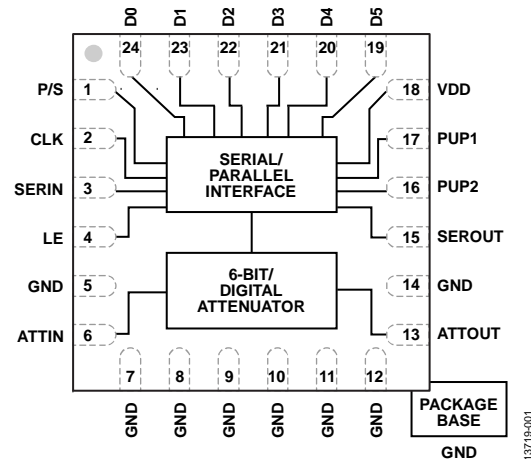

Figure 1.

The [HMC1122](#) operates on a single supply ranging from 3.3 V to 5 V with no performance change due to an on-chip regulator.

The device incorporates a driver that provides both serial and parallel control of the attenuator. The device also features a user-selectable power-up state and a serial output port for cascading other serial controlled components.

The [HMC1122](#) comes in a RoHS compliant, compact, 4 mm \times 4 mm LFCSP package, and is pin compatible to the [HMC624A](#).

A fully populated evaluation board is available.

Rev. B

[Document Feedback](#)

Information furnished by Analog Devices is believed to be accurate and reliable. However, no responsibility is assumed by Analog Devices for its use, nor for any infringements of patents or other rights of third parties that may result from its use. Specifications subject to change without notice. No license is granted by implication or otherwise under any patent or patent rights of Analog Devices. Trademarks and registered trademarks are the property of their respective owners.

One Technology Way, P.O. Box 9106, Norwood, MA 02062-9106, U.S.A.
Tel: 781.329.4700 ©2016–2017 Analog Devices, Inc. All rights reserved.
[Technical Support](#) www.analog.com

TABLE OF CONTENTS

Features	1	Input Power Compression and Third-Order Intercept.....	9
Applications.....	1	Theory of Operation	10
Functional Block Diagram	1	Power Supply.....	10
General Description	1	RF Input and Output	10
Revision History	2	Serial or Parallel Mode Selection	10
Specifications.....	3	Serial Mode Interface.....	10
Timing Specifications	4	Parallel Mode Interface.....	11
Absolute Maximum Ratings.....	5	Power-Up Interface	11
ESD Caution.....	5	Applications Information	12
Pin Configuration and Function Descriptions.....	6	Evaluation Printed Circuit Board	12
Interface Schematics.....	6	Evaluation Board Schematic and Artwork	13
Typical Performance Characteristics	7	Outline Dimensions	15
Insertion Loss, Return Loss, State Error, Step Error, and Relative Phase.....	7	Ordering Guide	15

REVISION HISTORY

9/2017—Rev. A to Rev. B

Changed CP-24-16 to HCP-24-3.....	Throughout
Updated Outline Dimensions	15
Changes to Ordering Guide	15

8/2017—Rev. 0 to Rev. A

Added Timing Specifications Section.....	4
Moved Table 2	4
Change to Figure 5	6
Changes to Figure 26.....	11
Updated Outline Dimensions	15

4/2016—Revision 0: Initial Version

SPECIFICATIONS

$V_{DD} = 3.3 \text{ V to } 5 \text{ V}$, $T_A = 25^\circ\text{C}$, 50Ω system, unless otherwise noted.

Table 1.

Parameter	Symbol	Test Conditions/Comments	Min	Typ	Max	Unit
FREQUENCY RANGE			0.1		6.0	GHz
INSERTION LOSS		At 0.2 GHz to 1.0 GHz		1.1	1.8	dB
		At 1.0 GHz to 2.0 GHz		1.3	2.0	dB
		At 2.0 GHz to 4.0 GHz		1.7	2.4	dB
		At 4.0 GHz to 6.0 GHz		2.0	2.8	dB
ATTENUATION		At 0.2 GHz to 6 GHz				
Range		Between minimum and maximum attenuation states		31.5		dB
Step Size		Between any successive attenuation states		0.5		dB
Step Error		Between any successive attenuation states		< ± 0.1		dB
Accuracy		All attenuation states; referenced to insertion loss state	-(0.1 + 4% of attenuation state)		+(0.1 + 4% of attenuation state)	dB
Overshoot		Between all attenuation states		<0.1		dB
RETURN LOSS (ATTIN and ATTOUT)		At 1.0 GHz, minimum attenuation (worst case)		24		dB
		At 2.0 GHz, minimum attenuation (worst case)		22		dB
		At 4.0 GHz, minimum attenuation (worst case)		22		dB
		At 6.0 GHz, maximum attenuation (worst case)		21		dB
RELATIVE PHASE		Between minimum and maximum attenuation states				
		At 1.0 GHz		6		Degrees
		At 2.0 GHz		18		Degrees
		At 4.0 GHz		38		Degrees
		At 6.0 GHz		58		Degrees
SWITCHING CHARACTERISTICS		Between all attenuation states				
Rise and Fall Time	t_{RISE}, t_{FALL}	10% to 90% of RF output		60		ns
On and Off Time	t_{ON}, t_{OFF}	50% V_{CTL} to 90% of RF output		150		ns
0.1 dB Settling Time		50% V_{CTL} to 0.1 dB of final RF output		200		ns
0.05 dB Settling Time		50% V_{CTL} to 0.05 dB of final RF output		250		ns
INPUT LINEARITY		All attenuation states, 0.2 GHz to 6 GHz				
Input 0.1 dB Compression	P0.1dB			30		dBm
Input Third-Order Intercept	IP3	Two-tone input power = 15 dBm each tone, $\Delta f = 1 \text{ MHz}$		55		dBm
SUPPLY CURRENT	I_{DD}	$V_{DD} = 3.3 \text{ V}$		0.3		mA
		$V_{DD} = 5.0 \text{ V}$		0.4		mA

Parameter	Symbol	Test Conditions/Comments	Min	Typ	Max	Unit
DIGITAL CONTROL INPUTS						
Input Voltage		P/S, CLK, SERIN, LE, D0 to D5, PUP1, and PUP2 pins				
Low	V_{INL}	$V_{DD} = 3.3\text{ V}$	0		0.5	V
		$V_{DD} = 5.0\text{ V}$	0		0.8	V
High	V_{INH}	$V_{DD} = 3.3\text{ V}$	2.0		3.3	V
		$V_{DD} = 5.0\text{ V}$	3.5		5.0	V
Low and High Input Current	I_{INL}, I_{INH}	$V_{DD} = 3.3\text{ V to }5\text{ V}$		<1		μA
DIGITAL CONTROL OUTPUT						
Output Voltage		SEROUT				
Low	V_{OUTL}			± 0.1		V
High	V_{OUTH}			$V_{DD} \pm 0.1$		V
Low and High Output Current	I_{OUTL}, I_{OUTH}				1	mA
RECOMMENDED OPERATING CONDITIONS						
Supply Voltage	V_{DD}		3.0		5.4	V
Digital Control Voltage Range	V_{CTL}		0		V_{DD}	V
RF Input Power	P_{IN}	All attenuation states, $T_{CASE} = 85^{\circ}\text{C}$			24	dBm
Case Temperature	T_{CASE}		-40		+85	$^{\circ}\text{C}$

TIMING SPECIFICATIONS

See Figure 26 and Figure 27 for the timing diagrams.

Table 2.

Parameter	Description	Min	Typ	Max	Unit
t_{SCK}	Minimum serial period, see Figure 26	70			ns
t_{CS}	Control setup time, see Figure 26	15			ns
t_{CH}	Control hold time, see Figure 26		20		ns
t_{LN}	LE setup time, see Figure 26	15			ns
t_{LEW}	Minimum LE pulse width, see Figure 26 and Figure 27		10		ns
t_{LES}	Minimum LE pulse spacing, see Figure 26		630		ns
t_{CKN}	Serial clock hold time from LE, see Figure 26		0		ns
t_{PH}	Hold time, see Figure 27		10		ns
t_{PS}	Setup time, see Figure 27		2		ns

ABSOLUTE MAXIMUM RATINGS

Table 3.

Parameter	Rating
RF Input Power, P_{IN} ($T_{CASE} = 85^{\circ}C$)	25 dBm
Supply Voltage	-0.3 V to +5.5 V
Digital Control Input Voltage	-0.3 V to $V_{DD} + 0.5$ V
Continuous Power Dissipation, P_{DISS}	0.31 W
Junction to Case Thermal Resistance, θ_{JC} (at Maximum Power Dissipation)	156°C/W
Temperature	
Junction, T_J	135°C
Storage	-65°C to +150°C
Reflow	260°C (MSL3 Rating)
ESD Sensitivity	
Human Body Model (HBM)	2 kV (Class 2)

Stresses at or above those listed under Absolute Maximum Ratings may cause permanent damage to the product. This is a stress rating only; functional operation of the product at these or any other conditions above those indicated in the operational section of this specification is not implied. Operation beyond the maximum operating conditions for extended periods may affect product reliability.

Only one absolute maximum rating can be applied at any one time.

ESD CAUTION



ESD (electrostatic discharge) sensitive device. Charged devices and circuit boards can discharge without detection. Although this product features patented or proprietary protection circuitry, damage may occur on devices subjected to high energy ESD. Therefore, proper ESD precautions should be taken to avoid performance degradation or loss of functionality.

PIN CONFIGURATION AND FUNCTION DESCRIPTIONS

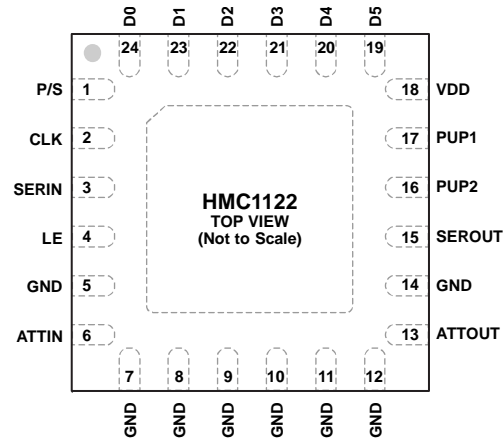

NOTES
 1. THE EXPOSED PAD MUST BE CONNECTED TO GROUND FOR PROPER OPERATION.

Figure 2. Pin Configuration (Top View)

Table 4. Pin Function Descriptions

Pin No.	Mnemonic	Description
1	P/S	Parallel/Serial Mode Select. For parallel mode operation, set this pin to low. For serial mode operation, set this pin to high.
2	CLK	Serial Interface Clock Input.
3	SERIN	Serial Interface Data Input.
4	LE	Latch Enable Input.
5, 7 to 12, 14	GND	Ground. These pins must be connected to ground.
6	ATTIN	Attenuator RF Input. This pin can also be used as an output because the design is bidirectional. ATTIN is dc-coupled and matched to 50 Ω. An external dc blocking capacitor is required.
13	ATTOUT	Attenuator RF Output. This pin can also be used as an input because the design is bidirectional. ATTOUT is dc-coupled and matched to 50 Ω. An external dc blocking capacitor is required.
15	SEROUT	Serial Interface Data Output. Serial input data is delayed by six clock cycles.
16, 17	PUP2, PUP1	Power-Up State Selection Bits. These pins set the attenuation value at power-up (see Table 7). There is no internal pull-up or pull-down resistor on these pins; therefore, they must always be kept at a valid logic level (V_{IH} or V_{IL}) and not be left floating.
18	VDD	Power Supply.
19 to 24	D5 to D0	Parallel Control Voltage Inputs. These pins select the required attenuation (see Table 6). There is no internal pull-up or pull-down resistor on these pins; therefore, they must always be kept at a valid logic level (V_{IH} or V_{IL}) and not be left floating.
	EPAD	Exposed Pad. The exposed pad must be connected to ground for proper operation.

INTERFACE SCHEMATICS

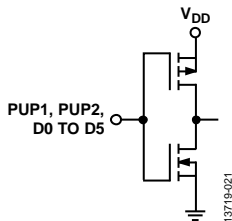

Figure 3. PUP1, PUP2, and D0 to D5 Interface Schematic

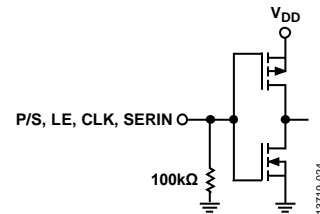

Figure 5. P/S, LE, CLK, and SERIN Interface Schematic

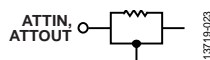

Figure 4. ATTIN, ATTOUT Interface Schematic



Figure 6. GND Interface Schematic

TYPICAL PERFORMANCE CHARACTERISTICS

INSERTION LOSS, RETURN LOSS, STATE ERROR, STEP ERROR, AND RELATIVE PHASE

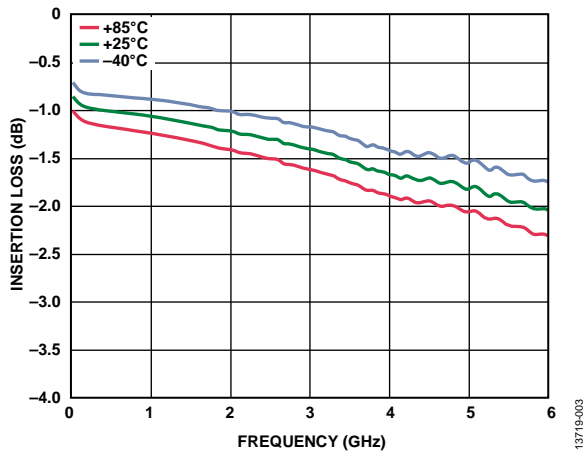

Figure 7. Insertion Loss vs. Frequency over Temperature

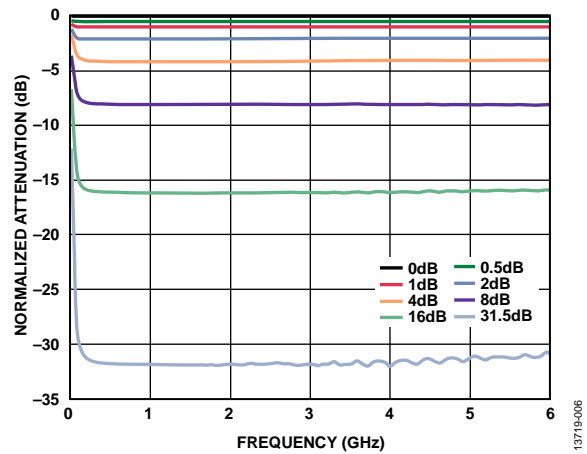

Figure 10. Normalized Attenuation vs. Frequency over Major Attenuation States

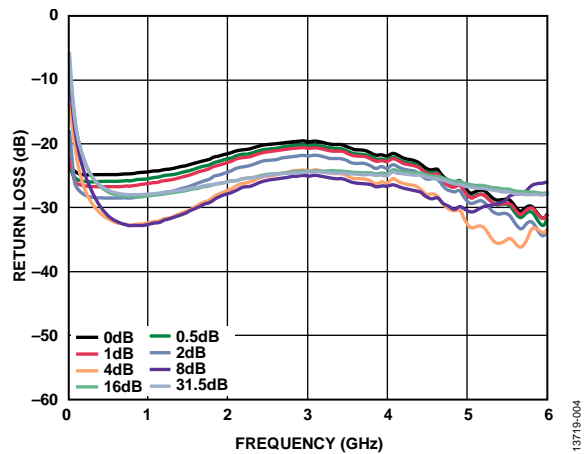

Figure 8. Input Return Loss vs. Frequency over Major Attenuation States

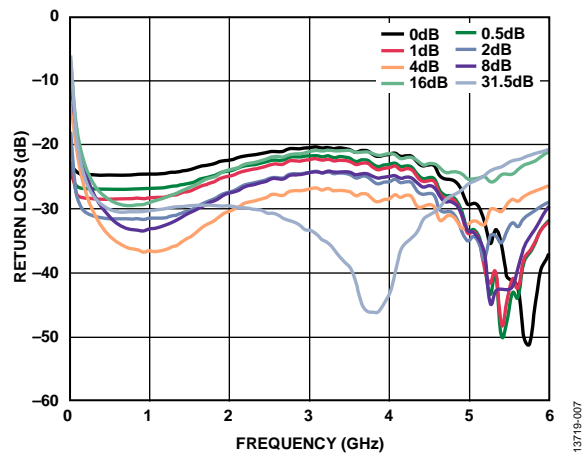

Figure 11. Output Return Loss vs. Frequency over Major Attenuation States

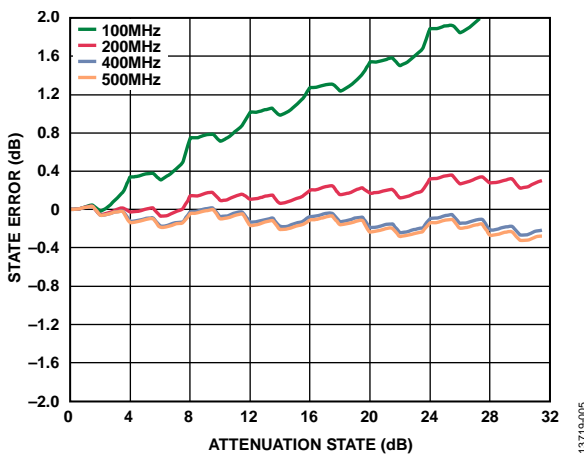

Figure 9. State Error vs. Attenuation State over Frequency (100 MHz to 500 MHz)

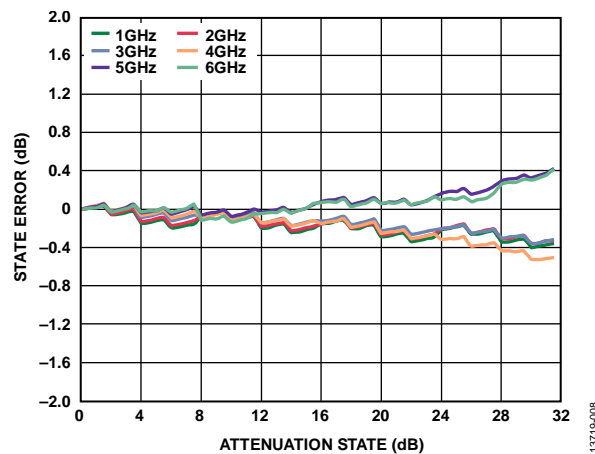

Figure 12. State Error vs. Attenuation State Over Frequency (1 GHz to 6 GHz)

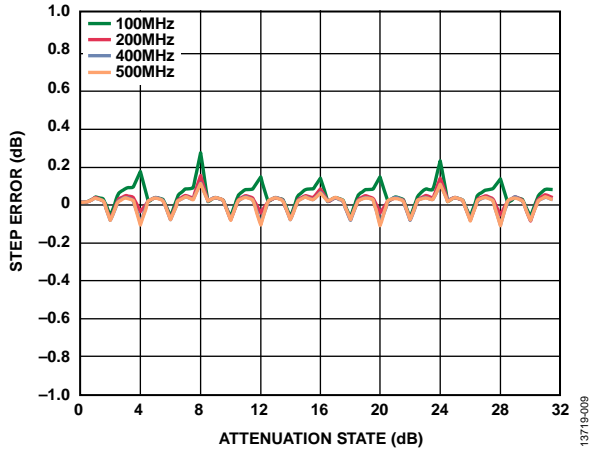

Figure 13. Step Error vs. Attenuation State over Frequency (100 MHz to 500 MHz)

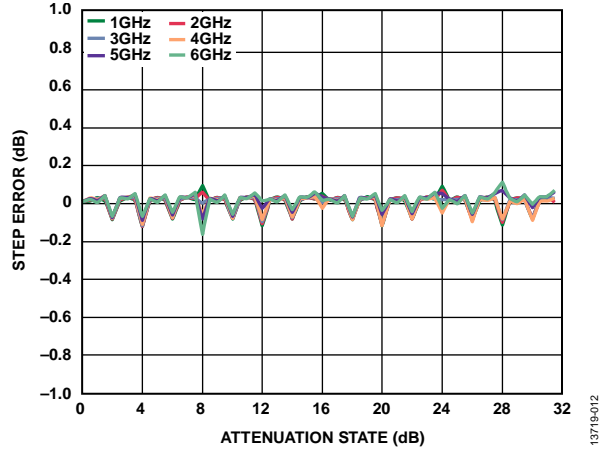

Figure 16. Step Error vs. Attenuation State over Frequency (1 GHz to 6 GHz)

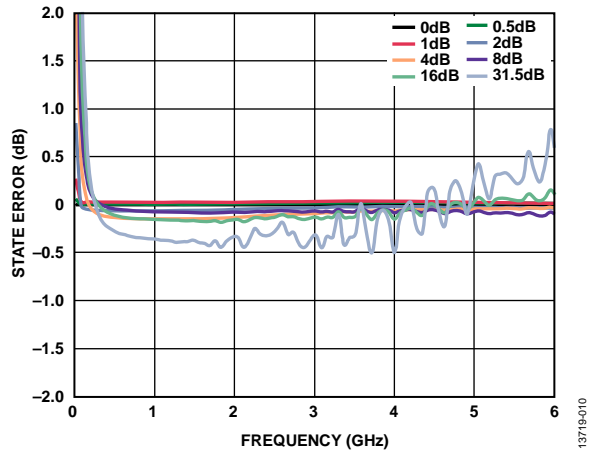

Figure 14. State Error vs. Frequency over Major Attenuation States

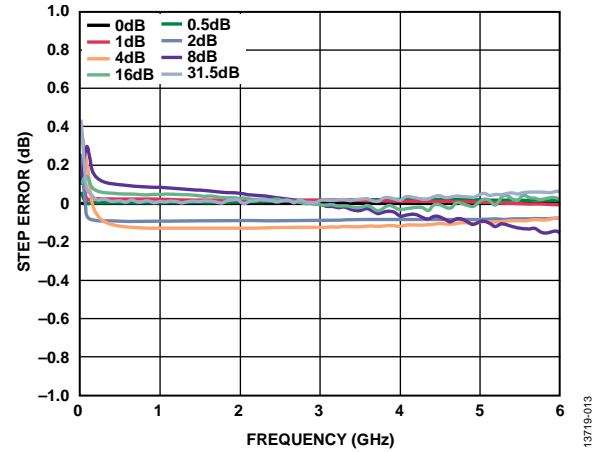

Figure 17. Step Error vs. Frequency over Major Attenuation States

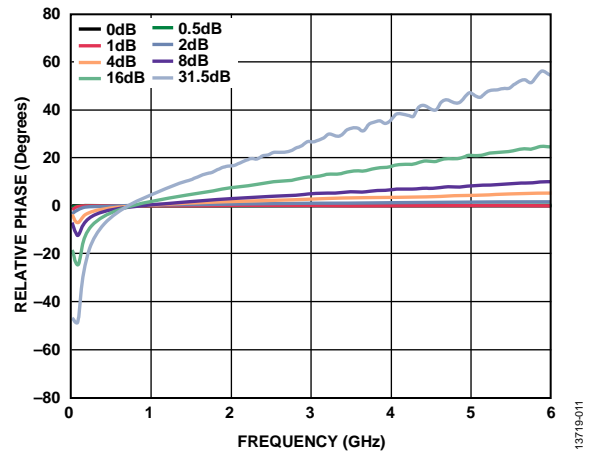

Figure 15. Relative Phase vs. Frequency over Major Attenuation States

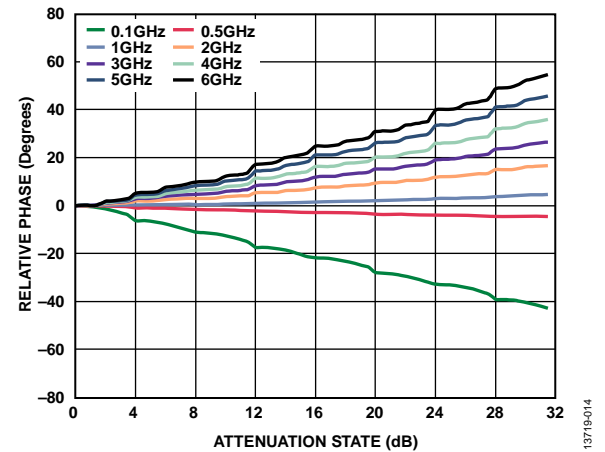

Figure 18. Relative Phase vs. Attenuation States over Frequency

INPUT POWER COMPRESSION AND THIRD-ORDER INTERCEPT

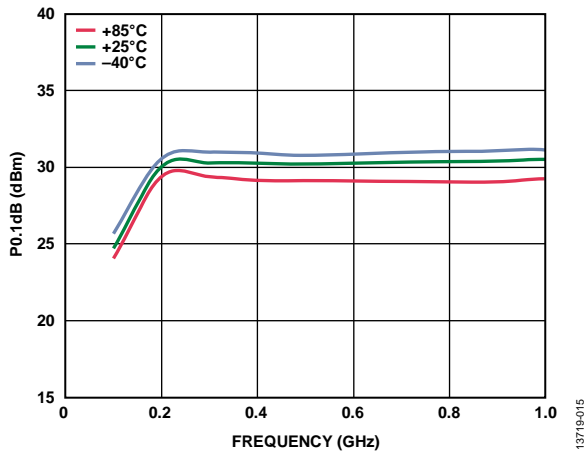

Figure 19. Input P0.1dB vs. Frequency (0.1 GHz to 1 GHz) at Minimum Attenuation State over Temperature

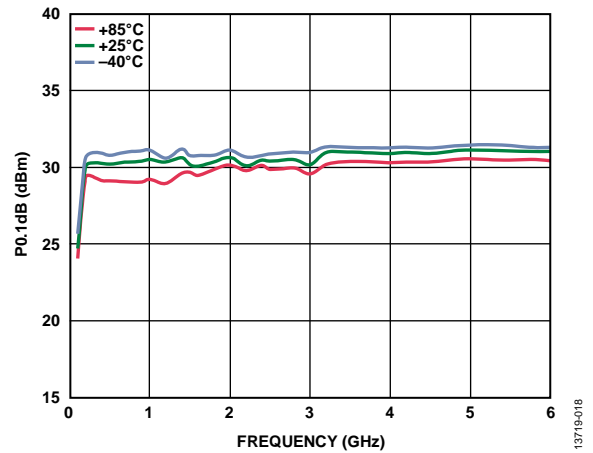

Figure 22. Input P0.1dB vs. Frequency (0.1 GHz to 6 GHz) at Minimum Attenuation State over Temperature

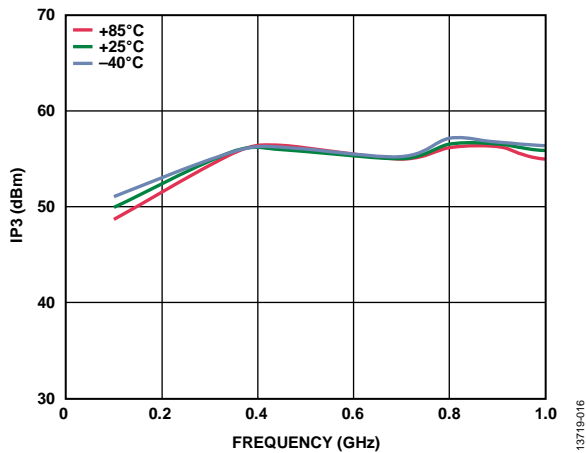

Figure 20. Input IP3 vs. Frequency (0.1 GHz to 1 GHz) at Minimum Attenuation State over Temperature

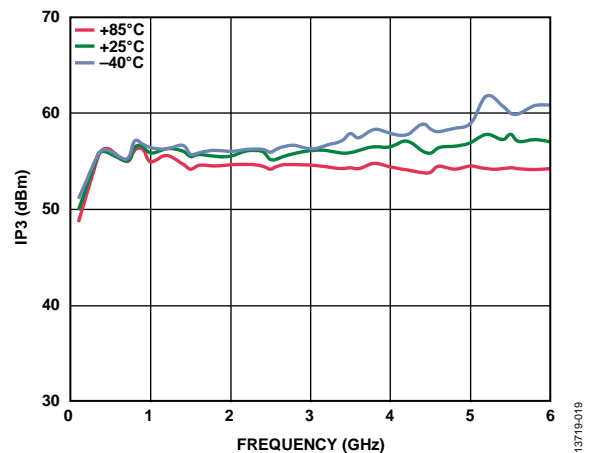

Figure 23. Input IP3 vs. Frequency (0.1 GHz to 6 GHz) at Minimum Attenuation State over Temperature

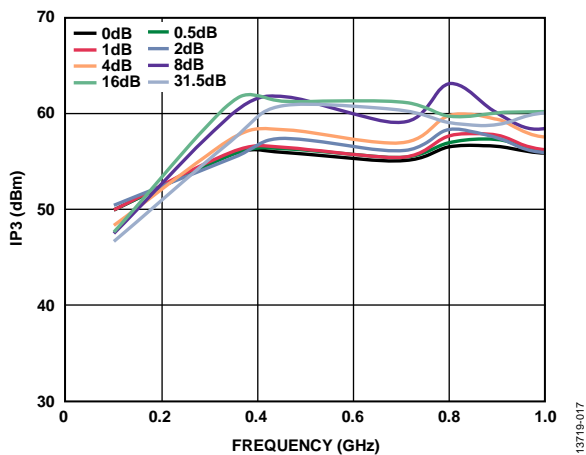

Figure 21. Input IP3 vs. Frequency (0.1 GHz to 1 GHz) over Major Attenuation States

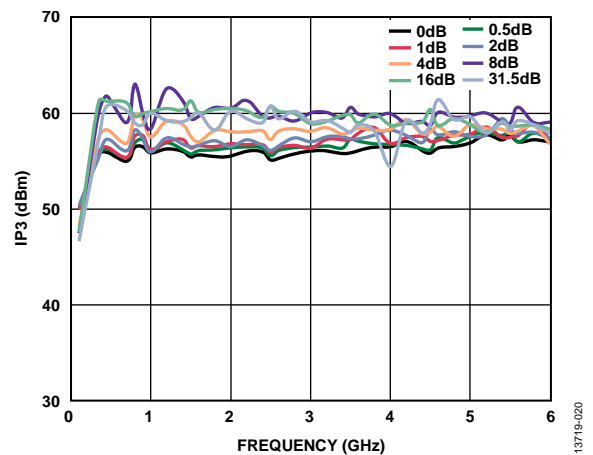

Figure 24. Input IP3 vs. Frequency (0.1 GHz to 6 GHz) over Major Attenuation States

THEORY OF OPERATION

The HMC1122 incorporates a 6-bit fixed attenuator array that offers an attenuation range of 31.5 dB in 0.5 dB steps. An integrated driver enables both serial and parallel mode control of the attenuator array (see Figure 25).

POWER SUPPLY

The HMC1122 requires a single dc voltage applied to the VDD pin. The ideal power-up sequence is as follows:

1. Connect the GND pin to a ground reference.
2. Apply a supply voltage to the VDD pin.
3. Power up the digital control inputs. The relative order of the digital control inputs is not important.
4. Apply an RF input signal to ATTIN or ATTOUT.

RF INPUT AND OUTPUT

The attenuator in the HMC1122 is bidirectional; ATTIN and ATTOUT pins are interchangeable as the RF input and output ports. The attenuator is internally matched to 50 Ω at both the input and the output; therefore, no external matching components are required. RF pins are dc-coupled; therefore, dc blocking capacitors are required on the RF lines.

SERIAL OR PARALLEL MODE SELECTION

The HMC1122 can be controlled in either serial or parallel mode by setting the P/S pin to high or low, respectively (see Table 5).

Table 5. Mode Selection

P/S	Control Mode
Low	Parallel
High	Serial

SERIAL MODE INTERFACE

The HMC1122 has a 3-wire serial peripheral interface (SPI): serial data input (SERIN), clock (CLK), and latch enable (LE). The serial control interface is activated when P/S is set to high.

In serial mode, the 6-bit SERIN data is clocked MSB first on the rising CLK edges into the shift register and then LE must be toggled high to latch the new attenuation state into the device. LE must be set to low to clock new 6-bit data into the shift register because CLK is masked to prevent the attenuator value from changing if LE is kept high. See Figure 26 in conjunction with Table 6 and Table 2.

The HMC1122 also features a serial data output pin, SEROUT, that outputs serial input data delayed by six clock cycles to control the cascaded attenuator using a single SPI bus.

In serial mode operation, the parallel control inputs must always be kept at a valid logic level (V_{IH} or V_{IL}) and not be left floating. It is recommended to connect all parallel control inputs (D0 to D5) to ground.

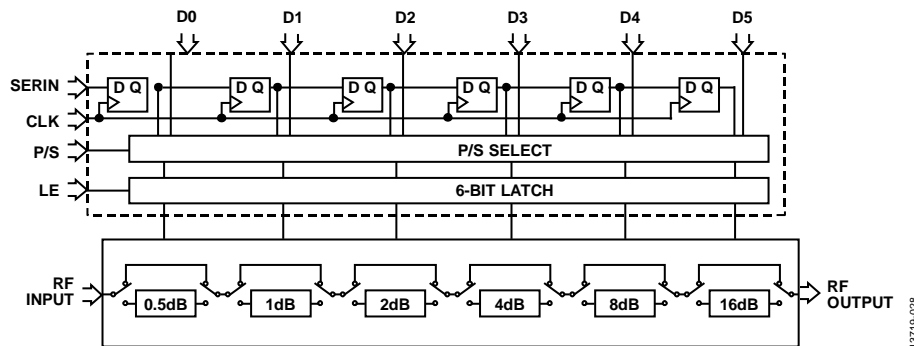

Figure 25. Functional Block Diagram

Table 6. D5 to D0 Truth Table

Digital Control Input ¹						Attenuation State (dB)
D5	D4	D3	D2	D1	D0	
High	High	High	High	High	High	0 (Reference)
High	High	High	High	High	Low	0.5
High	High	High	High	Low	High	1.0
High	High	High	Low	High	High	2.0
High	High	Low	High	High	High	4.0
High	Low	High	High	High	High	8.0
Low	High	High	High	High	High	16.0
Low	Low	Low	Low	Low	Low	31.5

¹ Any combination of the control voltage input states shown in Table 6 provides an attenuation equal to the sum of the bits selected.

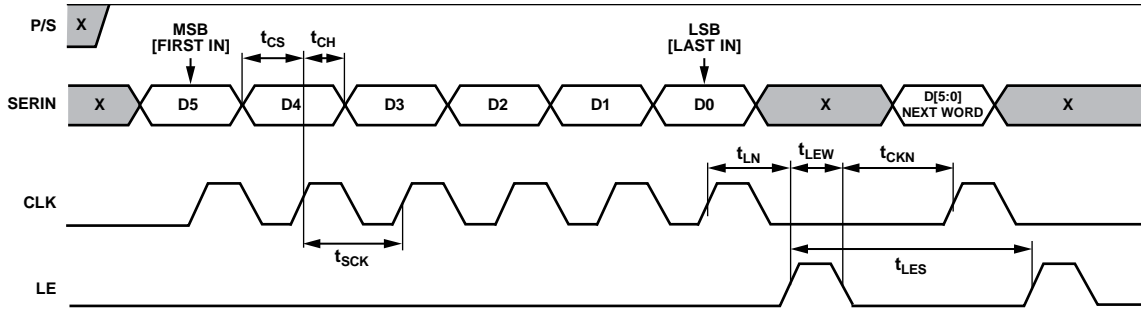

Figure 26. Serial Mode Timing Diagram

PARALLEL MODE INTERFACE

The HMC1122 has six digital control inputs, D0 (LSB) to D5 (MSB), to select the desired attenuation state in parallel mode, as shown in Table 6. The parallel control interface is activated when P/S is set to low. In parallel mode operation, the parallel control inputs (D0 to D5) must always be kept at a valid logic level (V_{IH} or V_{IL}). It is recommended to use pull-down resistors on all parallel control input lines if the device driving them goes to a high impedance state during hibernation.

There are two modes of parallel operation: direct parallel and latched parallel.

Direct Parallel Mode

The LE pin must be kept high. The attenuation state is changed by the control voltage inputs (D0 to D5) directly. This mode is ideal for manual control of the attenuator.

Latched Parallel Mode

The LE pin must be kept low when changing the control voltage inputs (D0 to D5) to set the attenuation state. When the desired state is set, LE must be toggled high to transfer the 6-bit data to the bypass switches of the attenuator array, and then toggled low to latch the change into the device until the next desired attenuation change (see Figure 27 in conjunction with Table 2).

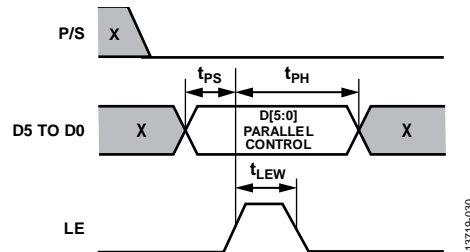

Figure 27. Latched Parallel Mode Timing Diagram

POWER-UP INTERFACE

The HMC1122 uses the PUP1 and PUP2 control voltage inputs to set the attenuation value to a known value at power-up before the initial control data word is provided in either serial or parallel mode. When the attenuator powers up with LE = low, the state of PUP1 and PUP2 determines the power-up state of the device per the truth table shown in Table 7. The attenuator latches in the desired power-up state approximately 200 ms after power-up.

Table 7. PUPx Truth Table¹

Attenuation State	LE	PUP1	PUP2
31.5 dB	Low	Low	Low
24.0 dB	Low	High	Low
16.0 dB	Low	Low	High
0 dB (Reference)	Low	High	High
Determined by D0 to D5	High	Don't care	Don't care

¹ The PUPx pins must always be kept at a valid logic level (V_{IH} or V_{IL}) and not be left floating.

APPLICATIONS INFORMATION

EVALUATION PRINTED CIRCUIT BOARD

The schematic of the [HMC1122](#) evaluation board is shown in Figure 28. The [HMC1122](#) evaluation board is constructed of a 4-layer material with a copper thickness of 0.7 mil on each layer. Every copper layer is separated with a dielectric material. The top dielectric material is 10 mil RO4350. The middle and bottom dielectric materials are FR-4, used for mechanical strength and overall board thickness of approximately 62 mil, which allows SMA connectors to be slipped in at the board edges.

All RF and dc traces are routed on the top copper layer. The RF transmission lines are designed using a coplanar waveguide (CPWG) model, with a width of 18 mil, spacing of 13 mil, and dielectric thickness of 10 mil, to have a characteristic impedance of 50 Ω . The inner and bottom layers are grounded planes to provide a solid ground for the RF transmission lines. For optimal electrical and thermal performance, as many vias as possible are arranged around transmission lines and under the package exposed pad. The evaluation board layout shown in Figure 29 serves as a recommendation for optimal and stable performance, as well as for improvement of thermal efficiency.

The evaluation board is grounded from the dc test point, TP1. The dc supply must be connected to the dc test point, TP2, of the evaluation board. Three decoupling capacitors are populated on the supply trace to filter high frequency noise.

The RF input and output ports (ATTIN and ATTOUT) are connected through 50 Ω transmission lines to the SMA connectors, J1 and J2, respectively. The ATTIN and ATTOUT ports are ac-coupled with capacitors of an appropriate value to ensure broadband performance. A thru calibration line connects J4 and J5; this transmission line is used to estimate the loss of the PCB over the environmental conditions being evaluated.

All the digital control pins are connected through digital signal traces to the 2 \times 9-pin header, J3. On the digital signal traces, provisions for an RC filter are made to clean any potential coupled noise. In normal operation, series resistors are 0 Ω and shunt capacitors are open.

The [HMC1122](#) evaluation board also uses two dual inline package (DIP), four-position single-pole dual-throw (SPDT) switches for the manual control of the device in direct parallel mode.

EVALUATION BOARD SCHEMATIC AND ARTWORK

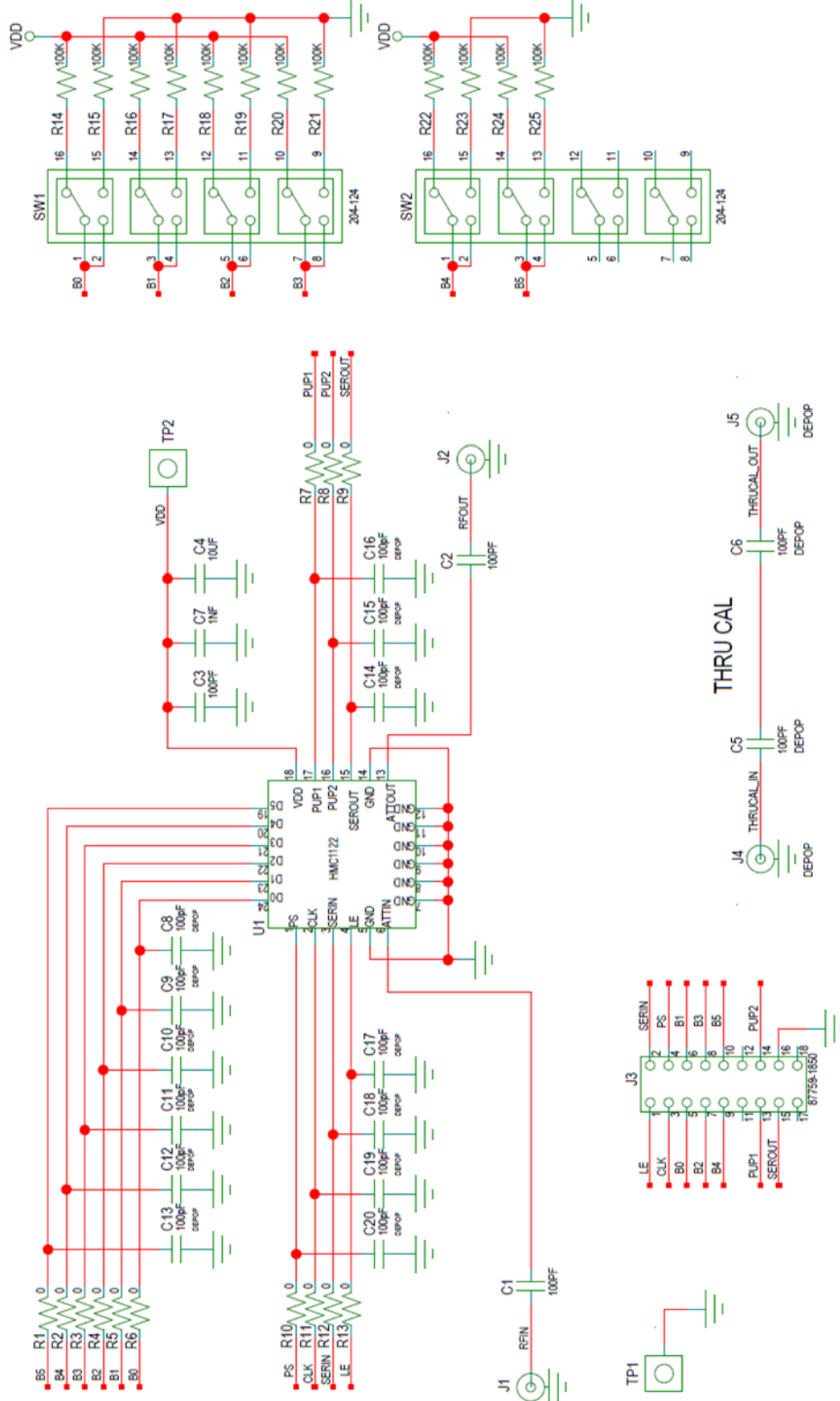

13719-025

Figure 28. Evaluation Board Schematic

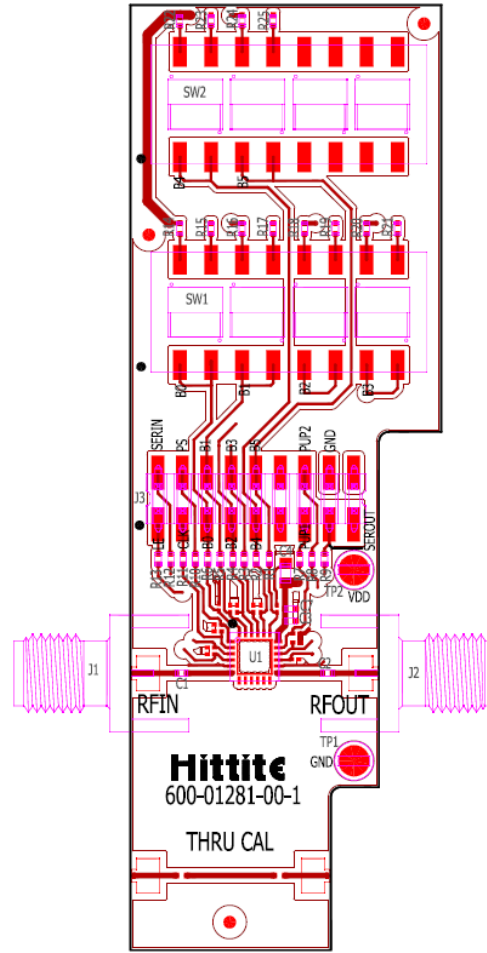

Figure 29. Evaluation Board Layout—Top View

Table 8. Evaluation Board Components

Component	Default Value	Description
J1, J2	Not applicable	SMA connector
J3	Not applicable	2 × 9-pin header
J4, J5	Do not insert	SMA connector
TP1, TP2	Not applicable	Through hole mount test point
C1, C2	100 pF	Capacitor, 0402 package
C3	100 pF	Capacitor, 0402 package
C4	10 μF	Capacitor, 0603 package
C7	1 nF	Capacitor, 0402 package
C5, C6	Do not insert	Capacitor, 0402 package
C8 to C20	Do not insert	Capacitor, 0402 package
SW1, SW2	Not applicable	SPDT four-position DIP switch
R1 to R13	0 Ω	Resistor, 0402 package
R14 to R25	100 kΩ	Resistor, 0402 package
U1	HMC1122	HMC1122 digital attenuator, Analog Devices, Inc.
PCB	EV2HMC1122LP4M	600-01281-00-1 evaluation PCB, Analog Devices

OUTLINE DIMENSIONS

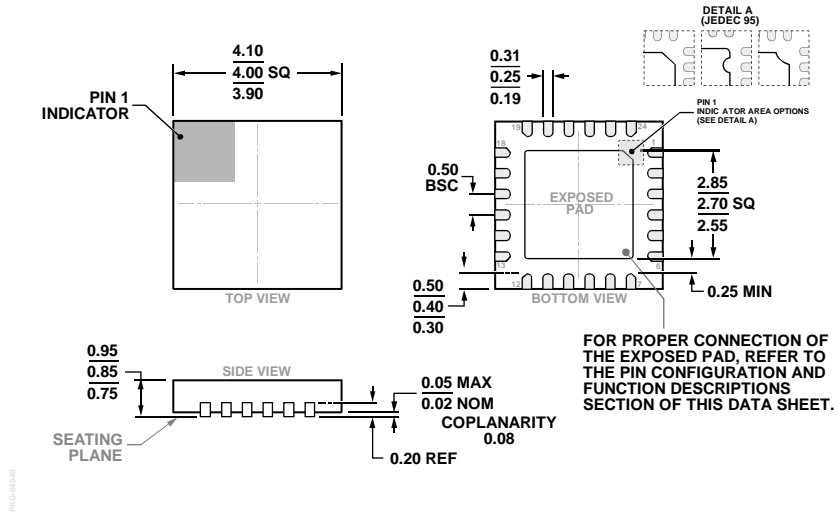

Figure 30. 24-Lead Lead Frame Chip Scale Package [LFCSP]
 4 mm x 4 mm Body and 0.85 mm Package Height
 (HCP-24-3)
 Dimensions shown in millimeters

ORDERING GUIDE

Model ¹	Temperature Range	MSL Rating ²	Package Description	Package Option	Branding ³
HMC1122LP4ME	-40°C to +85°C	MSL3	24-Lead Lead Frame Chip Scale Package [LFCSP]	HCP-24-3	H1122 XXXX
HMC1122LP4METR	-40°C to +85°C	MSL3	24-Lead Lead Frame Chip Scale Package [LFCSP]	HCP-24-3	H1122 XXXX
EV2HMC1122LP4M			Evaluation Board		

¹ All models are RoHS compliant.
² See the Absolute Maximum Ratings section.
³ XXXX is the 4-digit lot number.