

New PAN1026 Series Place and Play *Bluetooth*® Module



Dual Mode, Place and Play *Bluetooth* Module

Introducing Panasonic's *Bluetooth* dual mode, place and play RF module, the PAN1026 featuring an embedded ARM processor, *Bluetooth* 4.0, serial port profile (SPP), command set API and integrated antenna. This cost-engineered solution is based on a single chip solution that integrates an ARM processor with a *Bluetooth* controller. *Bluetooth* 4.0 combines the data rate of *Bluetooth* Classic (3Mb/s) and ultra-fast connection time of *Bluetooth* Low Energy (3mS). *Bluetooth* Low Energy is designed to create low data rate networks using a minimum amount of power. The embedded serial port profile (SPP) frees application resources while the command set API creates a simple but flexible firmware interface. An onboard antenna does away with 2.4GHz RF circuit complexity.

Created with the design engineer in mind, product design cycles are greatly reduced using Panasonic's free of charge reference design and design review services¹. PCB layouts are simplified using available Gerber files and minimized with Panasonic's tiny footprint technology. The module is just 15.6mm x 8.7mm x 1.9mm and fully shielded to improve immunity. All Panasonic *Bluetooth* RF modules carry FCC, IC, CE and *Bluetooth* certifications.

The PAN1026 recognizes Apple's authentication coprocessor and supports *Bluetooth* communication² with Apple's iPhone and iPad®. Connectivity also includes Android, smart phones and all *Bluetooth* enabled devices³.

Prototyping and testing are accelerated by utilizing the EVAL_PAN1026 development kit and EasyDualMode software development environment. The EVAL_PAN1026 contains two PAN1026ETU development modules on Panasonic's ETU platform – ETU for Easy to Use. EasyDualMode allows both BLE and *Bluetooth* Classic application development in a single environment. EasyDualMode software is available free of charge on Panasonic's RF module website.

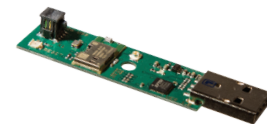

PAN1026ETU Development Module

1. Services are reserved for qualified customers. Contact one of Panasonic manufacturer's sales representatives for more information.

2. Apple authentication coprocessor and MFI certification are required for communicating with Apple Idevices.

3. Connectivity requires that devices support *Bluetooth* Serial Port Profile

*Apple iPad and iPhone are trademarks of Apple Inc

Features

- *Bluetooth* Version 4.0
- Industrial Temperature Range, -40 to +85°C
- High Sensitivity: -87dbm
- Output Power: 4dbm
- Single V_{CC} Supply: 1.7 to 3.6 V
- WiFi Coexistence
- High-Speed Interfaces: USB 2.0 UART up to 4.3 Mbps
- Integrated ARM 32-Bit Processor

Applications

- iOS and Android Devices
- Wireless Sensors
- Cable Replacement
- Instrumentation
- Medical
- Automotive

Block Diagram (PAN1026)

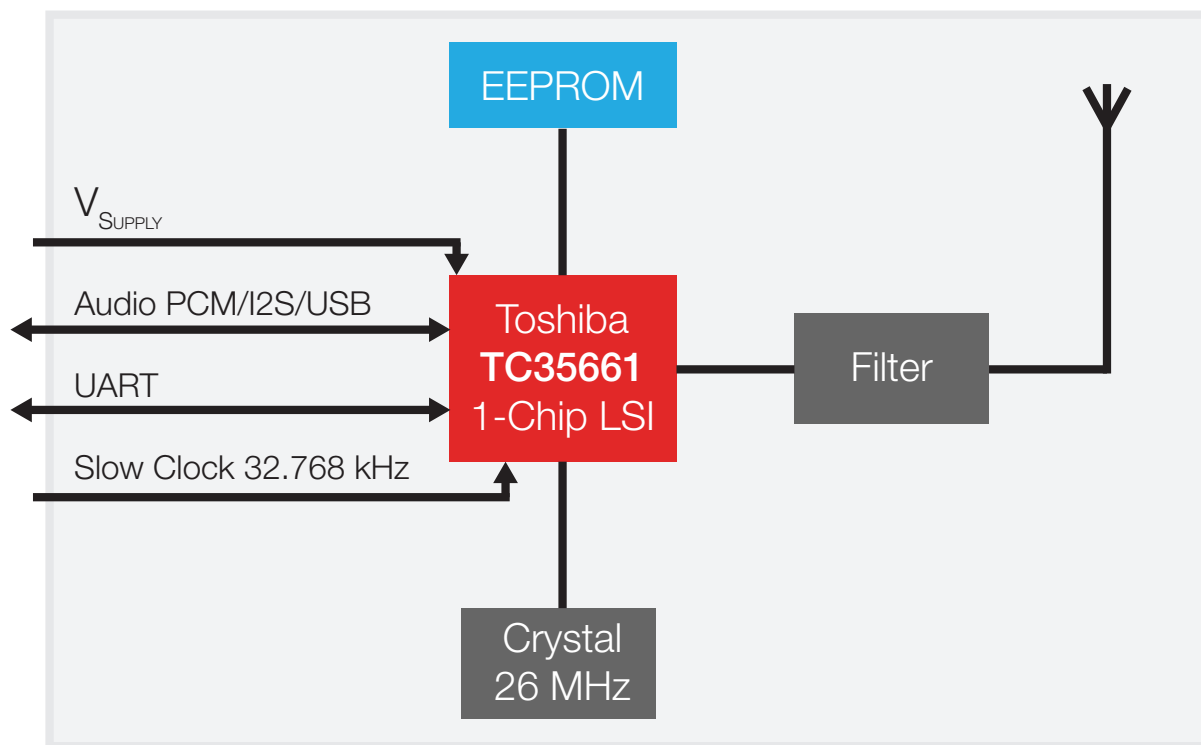

Technical Characteristics

Parameter	Value	Condition
Receiver Sensitivity	-87 dBm typ.	Ideal Signal
Output Power	+4 dBm typ.	@ 50 Ohm Antenna Pin
Power Supply	1.7 to 3.6 V	Single Voltage Operation
Transmit	46 mA	ACL, DH1
Receive	46 mA	ACL, DH1
Operating Temperature	-40 to +85°C	

Ordering Information

Part Number	Description
ENW-89837A3KF	PAN1026 <i>Bluetooth</i> Module, SPP, Integrated Antenna
EVAL_PAN1026	PAN1026 Evaluation Kit

Additional Information

For detailed specification information on the **PAN1026** Place and Play *Bluetooth* Module, visit our website at:

<http://www.panasonic.com/rfmodules/>