

## Evaluation Board for Single Differential Amplifiers Offered in 16-Lead LFCSP Packages

### FEATURES

- Enables quick breadboarding/prototyping
- User defined circuit configuration
- Edge mounted SMA connector provisions
- Easy connection to test equipment and other circuits
- RoHS compliant

### GENERAL DESCRIPTION

The Analog Devices, Inc., differential amplifier, 16-lead LFCSP evaluation board evaluates single, high speed, fully differential amplifiers offered in 16-lead LFCSP packages. The evaluation board is a bare board that enables users to quickly prototype a variety of single op amp circuits, which minimizes risk and reduces time to market. Figure 1 shows the component side of the bare evaluation board. Figure 2 shows the circuit side of the bare evaluation board.

The 6-layer evaluation board accepts SMA edge-mounted connectors on the inputs and outputs for efficient connection to test equipment or other circuitry. The ground plane, component placement, and supply bypassing minimize parasitic inductance and capacitance. The evaluation board components are primarily SMT 0603 case size, with the exception of the electrolytic bypass capacitors (C1 and C2), which are 3528 case size.

Figure 3 shows the evaluation board schematic and Figure 4 through Figure 6 show the interface schematics. The printed circuit board (PCB) assembly drawings are shown in Figure 7 and Figure 9. See Figure 8 and Figure 10 for the PCB layout patterns.

The layout pattern for the PCB is shown in Figure 8 and Figure 10.

### EVALUATION BOARD COMPONENT AND CIRCUIT SIDE DIAGRAMS

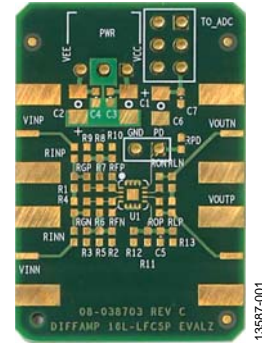

Figure 1. Evaluation Board, Component Side



Figure 2. Evaluation Board, Circuit Side

EVALUATION BOARD SCHEMATIC, ASSEMBLY DRAWINGS, AND LAYOUT PATTERNS

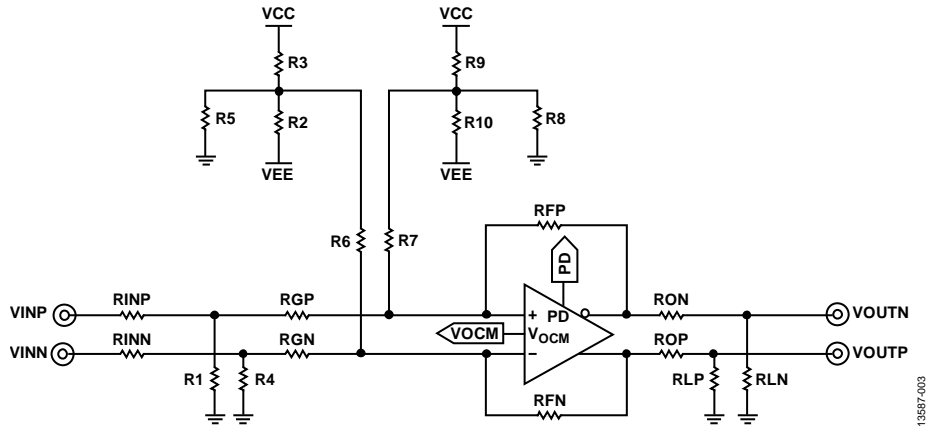

Figure 3. Differential Amplifier Evaluation Board Schematic

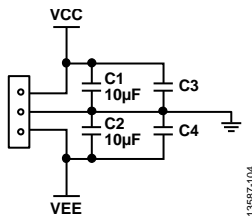

Figure 4. Supplies Interface

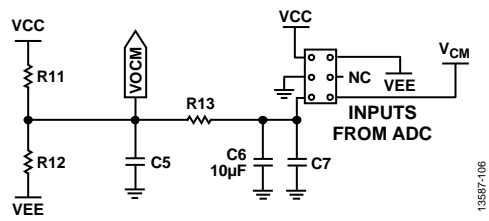

Figure 6. V<sub>OCM</sub> Interface

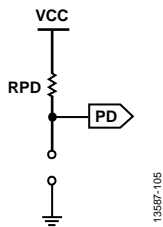

Figure 5. Power-Down Interface

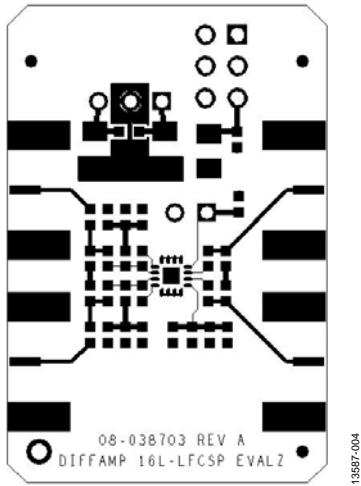

Figure 7. Component Side Assembly Drawing

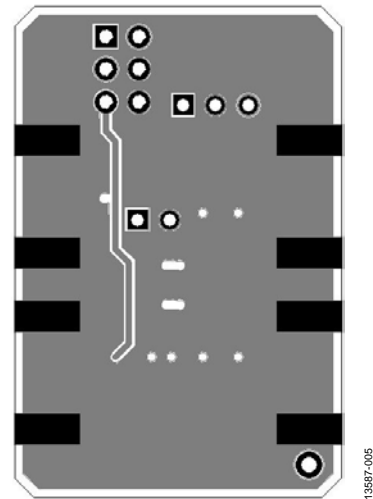

Figure 9. Circuit Side Assembly Drawing

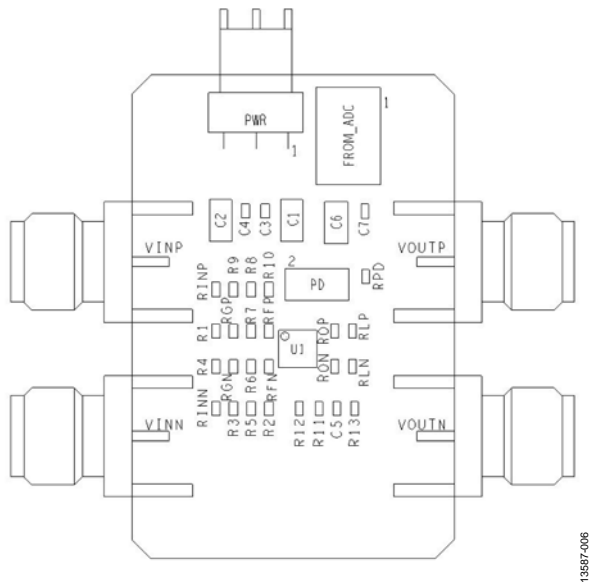

Figure 8. Component Side Layout Pattern

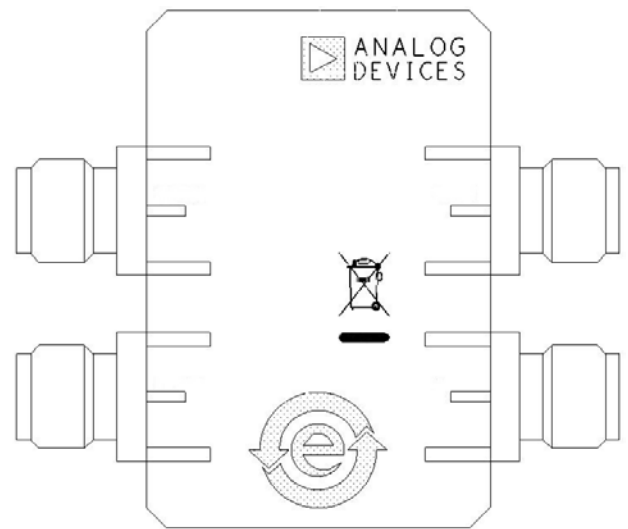

Figure 10. Circuit Side Layout Pattern

## ORDERING INFORMATION

### BILL OF MATERIALS

Table 1.

Qty.	Reference Designator	Description	Package
1	VCC, VEE, GND	Power connector	3-pin power connector
1	PD	Power-down/disable pin	2-pin header
3	C1, C2, C6	10 $\mu$ F	3528
4	C3, C4, C5, C7	Capacitor, user defined	C0603
4	VINP, VINN, VOUTP, VOUTN	Side launch SMA connector	SMA/SMT
1	ADC dc interface	ADC dc Interface	6-pin connector
11	RINP, RINN, RGP, RGN, RFP, RFN, ROP, RON, RLP, RLN, RPD	Resistor, user defined	R0603
13	R1 to R13	Resistor, user defined	R0603
1	Device under test (DUT)	Amplifier	16-lead LFCSP



#### ESD Caution

**ESD (electrostatic discharge) sensitive device.** Charged devices and circuit boards can discharge without detection. Although this product features patented or proprietary protection circuitry, damage may occur on devices subjected to high energy ESD. Therefore, proper ESD precautions should be taken to avoid performance degradation or loss of functionality.

#### Legal Terms and Conditions

By using the evaluation board discussed herein (together with any tools, components documentation or support materials, the "Evaluation Board"), you are agreeing to be bound by the terms and conditions set forth below ("Agreement") unless you have purchased the Evaluation Board, in which case the Analog Devices Standard Terms and Conditions of Sale shall govern. Do not use the Evaluation Board until you have read and agreed to the Agreement. Your use of the Evaluation Board shall signify your acceptance of the Agreement. This Agreement is made by and between you ("Customer") and Analog Devices, Inc. ("ADI"), with its principal place of business at One Technology Way, Norwood, MA 02062, USA. Subject to the terms and conditions of the Agreement, ADI hereby grants to Customer a free, limited, personal, temporary, non-exclusive, non-sublicensable, non-transferable license to use the Evaluation Board FOR EVALUATION PURPOSES ONLY. Customer understands and agrees that the Evaluation Board is provided for the sole and exclusive purpose referenced above, and agrees not to use the Evaluation Board for any other purpose. Furthermore, the license granted is expressly made subject to the following additional limitations: Customer shall not (i) rent, lease, display, sell, transfer, assign, sublicense, or distribute the Evaluation Board; and (ii) permit any Third Party to access the Evaluation Board. As used herein, the term "Third Party" includes any entity other than ADI, Customer, their employees, affiliates and in-house consultants. The Evaluation Board is NOT sold to Customer; all rights not expressly granted herein, including ownership of the Evaluation Board, are reserved by ADI. CONFIDENTIALITY. This Agreement and the Evaluation Board shall all be considered the confidential and proprietary information of ADI. Customer may not disclose or transfer any portion of the Evaluation Board to any other party for any reason. Upon discontinuation of use of the Evaluation Board or termination of this Agreement, Customer agrees to promptly return the Evaluation Board to ADI. ADDITIONAL RESTRICTIONS. Customer may not disassemble, decompile or reverse engineer chips on the Evaluation Board. Customer shall inform ADI of any occurred damages or any modifications or alterations it makes to the Evaluation Board, including but not limited to soldering or any other activity that affects the material content of the Evaluation Board. Modifications to the Evaluation Board must comply with applicable law, including but not limited to the RoHS Directive. TERMINATION. ADI may terminate this Agreement at any time upon giving written notice to Customer. Customer agrees to return to ADI the Evaluation Board at that time. LIMITATION OF LIABILITY. THE EVALUATION BOARD PROVIDED HEREUNDER IS PROVIDED "AS IS" AND ADI MAKES NO WARRANTIES OR REPRESENTATIONS OF ANY KIND WITH RESPECT TO IT. ADI SPECIFICALLY DISCLAIMS ANY REPRESENTATIONS, ENDORSEMENTS, GUARANTEES, OR WARRANTIES, EXPRESS OR IMPLIED, RELATED TO THE EVALUATION BOARD INCLUDING, BUT NOT LIMITED TO, THE IMPLIED WARRANTY OF MERCHANTABILITY, TITLE, FITNESS FOR A PARTICULAR PURPOSE OR NON-INFRINGEMENT OF INTELLECTUAL PROPERTY RIGHTS. IN NO EVENT WILL ADI AND ITS LICENSORS BE LIABLE FOR ANY INCIDENTAL, SPECIAL, INDIRECT, OR CONSEQUENTIAL DAMAGES RESULTING FROM CUSTOMER'S POSSESSION OR USE OF THE EVALUATION BOARD, INCLUDING BUT NOT LIMITED TO LOST PROFITS, DELAY COSTS, LABOR COSTS OR LOSS OF GOODWILL. ADI'S TOTAL LIABILITY FROM ANY AND ALL CAUSES SHALL BE LIMITED TO THE AMOUNT OF ONE HUNDRED US DOLLARS (\$100.00). EXPORT. Customer agrees that it will not directly or indirectly export the Evaluation Board to another country, and that it will comply with all applicable United States federal laws and regulations relating to exports. GOVERNING LAW. This Agreement shall be governed by and construed in accordance with the substantive laws of the Commonwealth of Massachusetts (excluding conflict of law rules). Any legal action regarding this Agreement will be heard in the state or federal courts having jurisdiction in Suffolk County, Massachusetts, and Customer hereby submits to the personal jurisdiction and venue of such courts. The United Nations Convention on Contracts for the International Sale of Goods shall not apply to this Agreement and is expressly disclaimed.