

⚠ Caution · Notice

■ Notice (Operating)

1. Environment Conditions

- (1) This product is designed for use in electrical equipment in the environment (temperature, humidity, atmospheric pressure, etc.) specified in this approval drawing. It may not be used in the following environments or under the following conditions:
 - (a) Ambient air containing corrosive gas (Chlorine gas, Hydrogen sulfide gas, Ammonia gas, Sulfuric acid gas, Nitric oxide gas, etc.)
 - (b) Ambient air containing volatile or combustible gas
 - (c) In liquid (water, oil, chemical solution, organic solvents, etc.)
 - (d) In environments with a high concentration of airborne particles
 - (e) In direct sunlight

(f) Dusty conditions

(g) In freezing

(h) Other environments similar to the above conditions

- (2) Contact the manufacturer before using the product in any of the above environments or under any of the above conditions.

2. Storage

Store in manufacturer's package or tightly re-closed box with the following conditions. Use this product within 6 months after receipt. Check the terminal solderability before use if the product has been stored for more than 6 months.

Temperature: -10 to +40°C

Humidity: 15 to 85% RH

■ Notice (Handling)

1. Automatic Measurement Probe (MM126036)

- Automatic measurement probe (MM126036) should be used under conditions in Fig. 1 for good connection without any damages.
- The engagement strokes from the flange to the tip of probe is 18.28mm to 19.78mm with vertical ($0\pm 2^\circ$) direction.

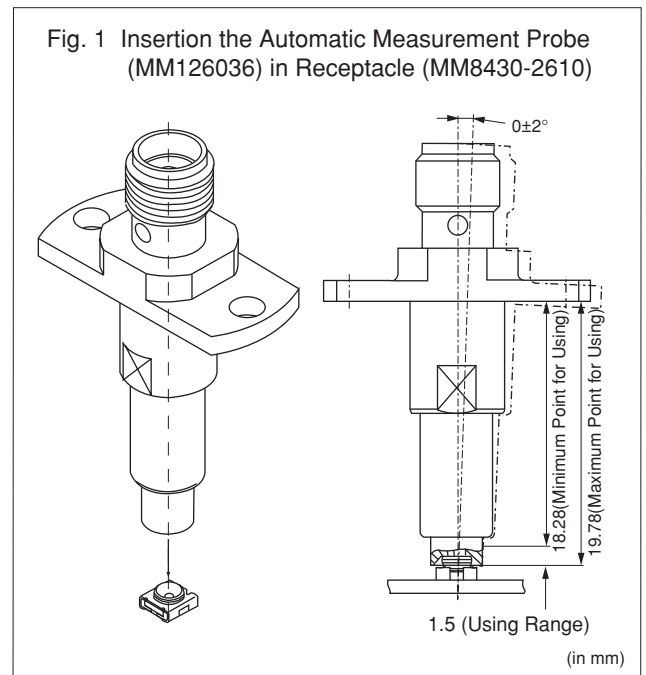

2. L Type Probe with Locking Function (MXHS83QE3000, MXHS83QH3000)

- Avoid pulling cable when probe is locked into connector.
- Avoid twisting probe or cable when engaging or disengaging from connector.
- Mechanical stress:

The stress to the connector should be limited as figure shown right.

 - (1) Stress to the housing.
Stress A and B: 0.5N max.
 - (2) Stress to the outer sleeve.
Stress C: 0.6N max.
Stress D: 0.6N max.
 - (3) Cable pull strength.
Stress E: 0.5N max.

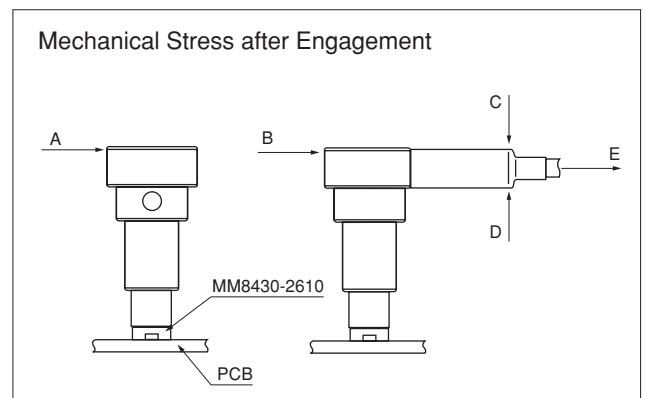

Continued on the following page. ↗

Caution · Notice

 Continued from the preceding page.

3. Usage Condition

- (1) Do not apply electrical voltage greater than specified in the catalog. It might cause degradation or destruction of the product. Even if it endures during a short time, long time qualification is not guaranteed.
- (2) Confirm that product performance is not influenced with any other components or materials which directly contact products.

4. Handling

Avoid excessive stress when handling and transporting printed circuit board after connector and/or assembly has been secured to PCB.