

- Precision SAW Filter
- 5.0 X 5.0 mm Surface-mount Case
- Single Ended Input and Output
- Complies with Directive 2002/95/EC (RoHS)

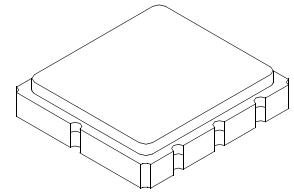

SF2172C

**280 MHz
SAW Filter**



SM5050-8

Absolute Maximum Ratings

Rating	Value	Units
Maximum Incident Power in Passband	+13	dBm
Maximum DC Voltage Between any two Non-ground Terminals	30	VDC
Storage Temperature Range in Tape and Reel	-40 to +85	°C
Suitable for Lead-free Soldering - Maximum Soldering Temperature	260 °C for 30 s	

Electrical Characteristics

Characteristic	Sym	Notes	Min	Typ	Max	Units
Nominal Center Frequency	f_C	1		280		MHz
Insertion Loss	IL_{MIN}	1		8.8	11	dB
Passband Ripple, $f_C \pm 7.5$ MHz		1		0.4	1.0	dB _{p-p}
Passband Ripple2, $f_C \pm (7.5 \text{ to } 8.5)$ MHz				0.7	2.0	dB _{p-p}
1 dB Bandwidth	BW_1	1	15	19.8		MHz
Group Delay Deviation, $f_C \pm 7.5$ MHz		1		24	50	ns
40 dB Bandwidth				29.5	31.0	MHz
Attenuation Referenced to IL_{MIN}						
$F_c \pm (15 \text{ to } 17)$ MHz			10	40		dB
$F_c \pm (17 \text{ to } 100)$ MHz			40	45		dB
Operating Temperature Range			-40		85	°C
Case Style			SM5050-8 5 x 5 mm Nominal Footprint			
Lid Symbolization, Y=year, WW=week, S=shift			RFM 852 YWWS			

Electrical Connections

Connection		Terminals
Port 1	Input	3
Port 2	Output	7
	Ground	All others
Dot indicates Pin 1		



CAUTION: Electrostatic Sensitive Device. Observe precautions for handling.

NOTES:

1. Unless noted otherwise, all specifications apply over the operating temperature range with filter soldered to the specified demonstration board with impedance matching to 50 Ω and measured with 50 Ω network analyzer.
2. Rejection is measured as attenuation below the minimum IL point in the passband. Rejection in final user application is dependent on PCB layout and external impedance matching design. See Application Note No. 42 for details.
3. The design, manufacturing process, and specifications of this filter are subject to change.
4. Tape and Reel Standard ANSI / EIA 481.
5. Either Port 1 or Port 2 may be used for either input or output in the design. However, impedances and impedance matching may vary between Port 1 and Port 2, so that the filter must always be installed in one direction per the circuit design.
6. US and international patents may apply.
7. Murata, stylized Murata logo, and Murata N.A., Inc. are registered trademarks of Murata Manufacturing Co., Ltd.

Frequency Response and Smith Charts

24 Oct 2008 08:05:05

CH1 S11 1 UFS
 1: 24 . 943 Ω -10 . 939 Ω 51 . 960 pF
 280 . 000 000 MHz

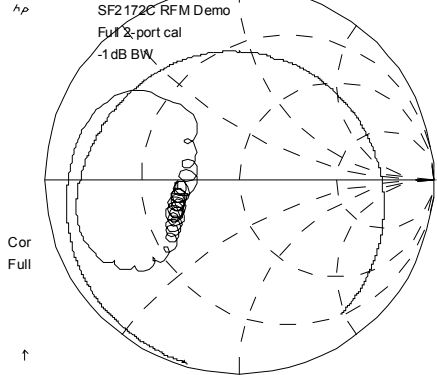

CH3 S22 1 UFS
 1: 21 . 977 Ω -59 . 455 Ω 9 . 5603 pF
 280 . 000 000 MHz

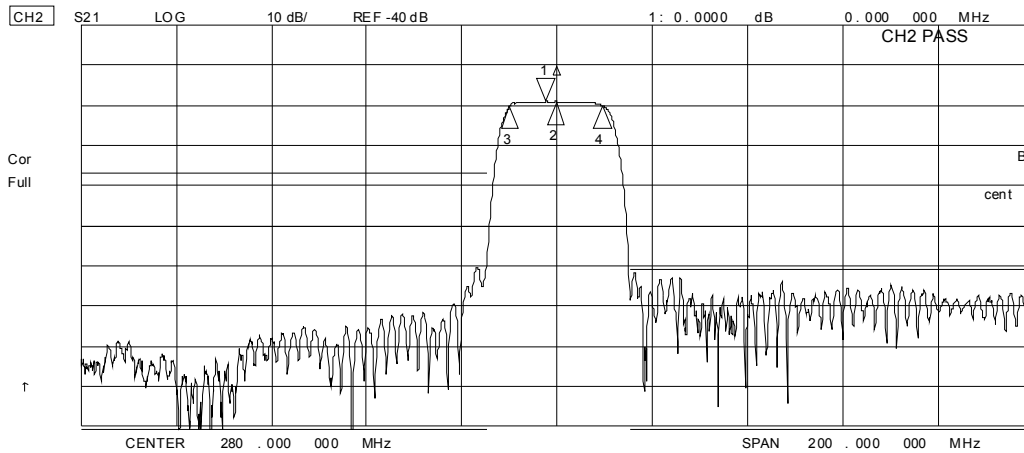
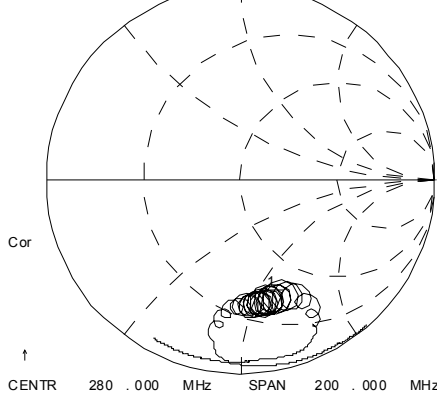

CH2 Markers
 Max Δ REF=1
 BW: 19 . 478600 MHz
 cent : 279 . 799573 MHz
 Q: 14 . 364
 loss : -9 . 0532 dB

Passband Response

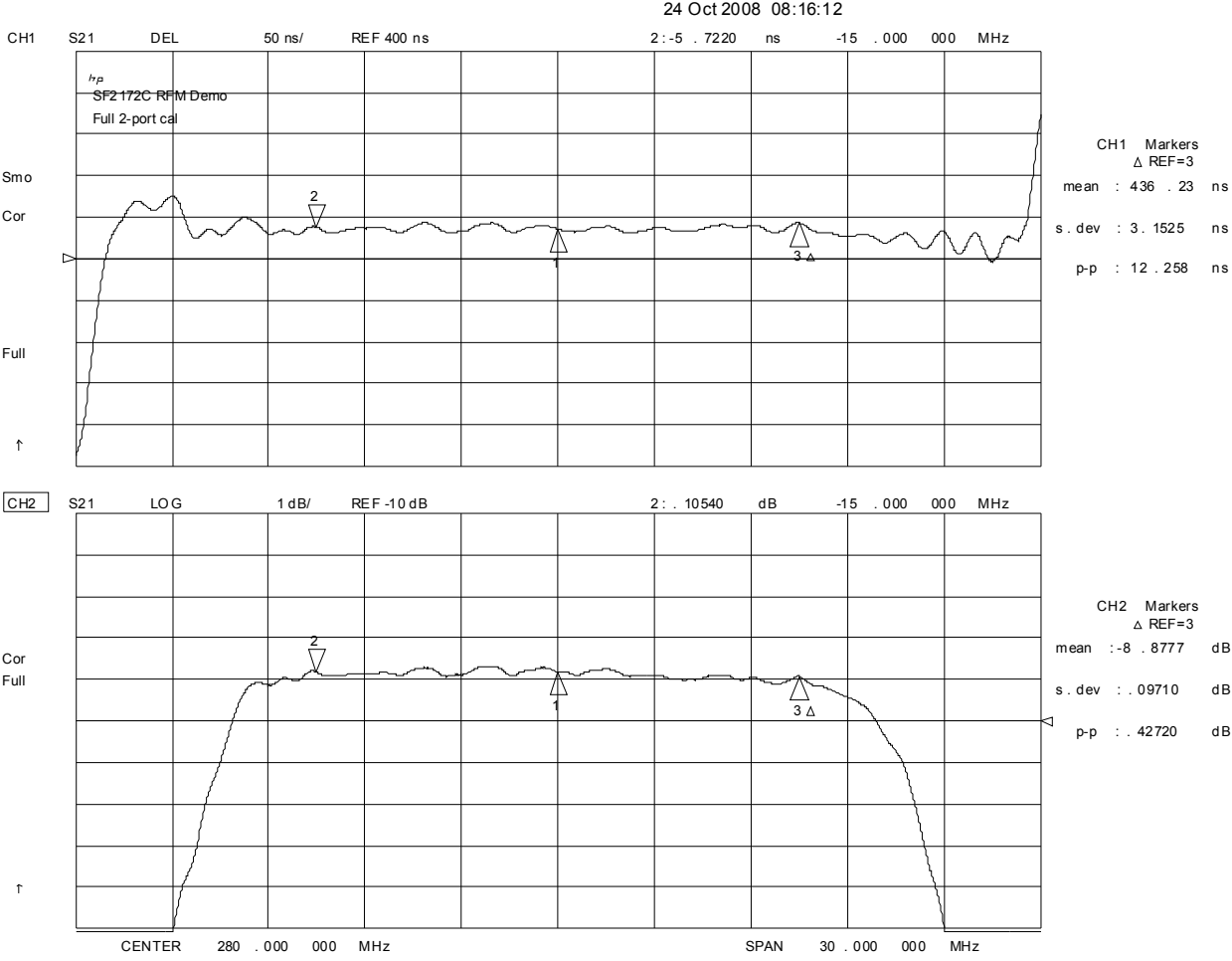

SF2172C Test Circuit

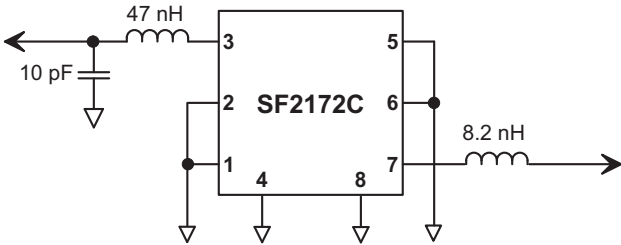

Downloaded from Arrow.com

SM5050-8 Case

8-Terminal Ceramic Surface-Mount Case 5.0 X 5.0 mm Nominal Footprint

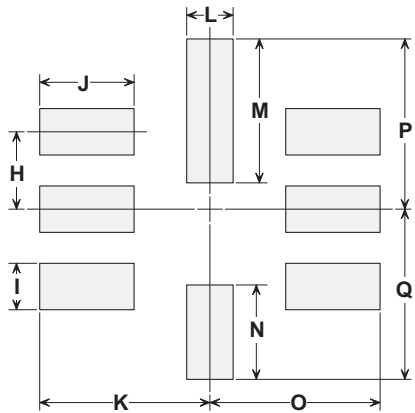
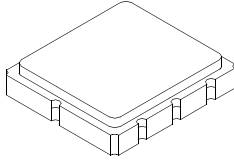

PCB Footprint

Case Dimensions

Dimension	mm			Inches		
	Min	Nom	Max	Min	Nom	Max
A	4.80	5.00	5.20	0.189	0.197	0.205
B	4.80	5.00	5.20	0.189	0.197	0.205
C	1.30	1.50	1.70	0.050	0.060	0.067
D	1.98	2.08	2.18	0.078	0.082	0.086
E	1.07	1.17	1.27	0.042	0.046	0.050
F	0.50	0.64	0.70	0.020	0.025	0.028
G	2.39	2.54	2.69	0.094	0.100	0.106
H		1.27			0.050	
I		0.76			0.030	
J		1.55			0.061	
K		2.79			0.110	
L		0.76			0.030	
M		2.36			0.093	
N		1.55			0.061	
O		2.79			0.110	
P		2.79			0.110	
Q		2.79			0.110	

Case Materials

Materials	
Solder Pad Plating	0.3 to 1.0 μm Gold over 1.27 to 8.89 μm Nickel
Lid Plating	2.0 to 3.0 μm Nickel
Body	Al_2O_3 Ceramic
	Pb Free

TOP VIEW

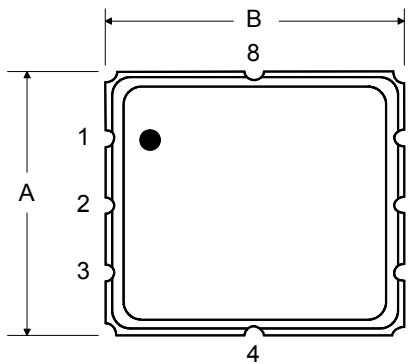

BOTTOM VIEW

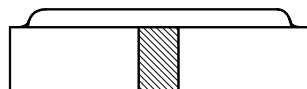
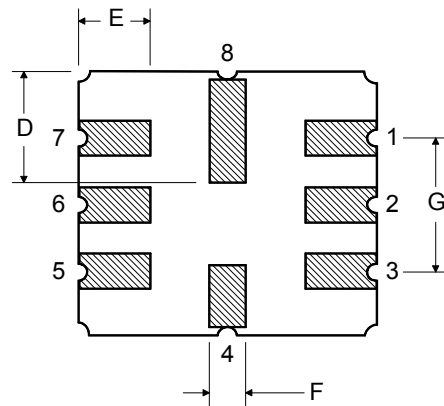

Tape and Reel Specifications

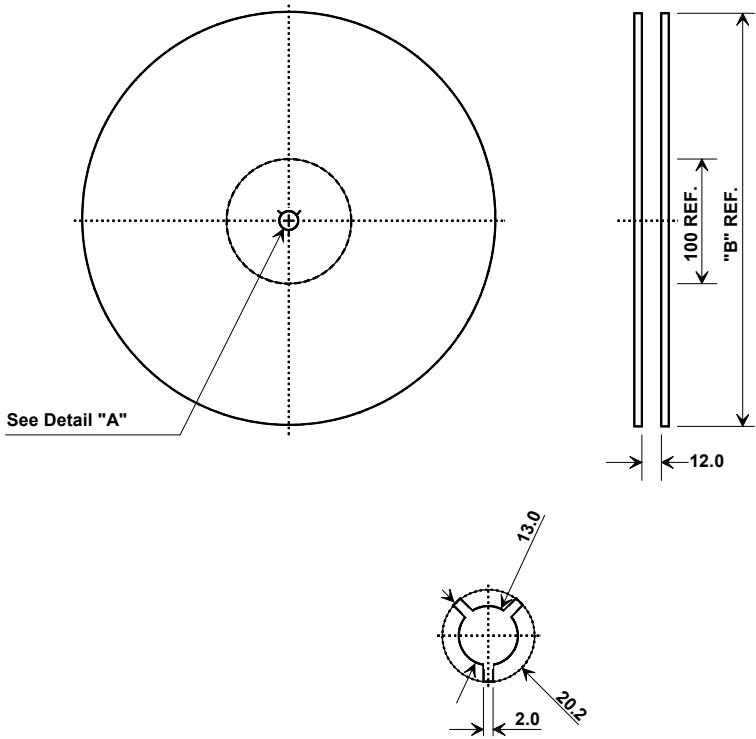

"B" Nominal Size		Quantity Per Reel
Inches	millimeters	
7	178	500
13	330	3000

COMPONENT ORIENTATION and DIMENSIONS

Carrier Tape Dimensions	
Ao	5.3 mm
Bo	5.3 mm
Ko	2.0 mm
Pitch	8.0 mm
W	12.0 mm

