

NICKEL METAL HYDRIDE BATTERIES: INDIVIDUAL DATA SHEET

HHR380A Cylindrical L-A size (HR 17/67)

Dimensions (with Tube) (mm)

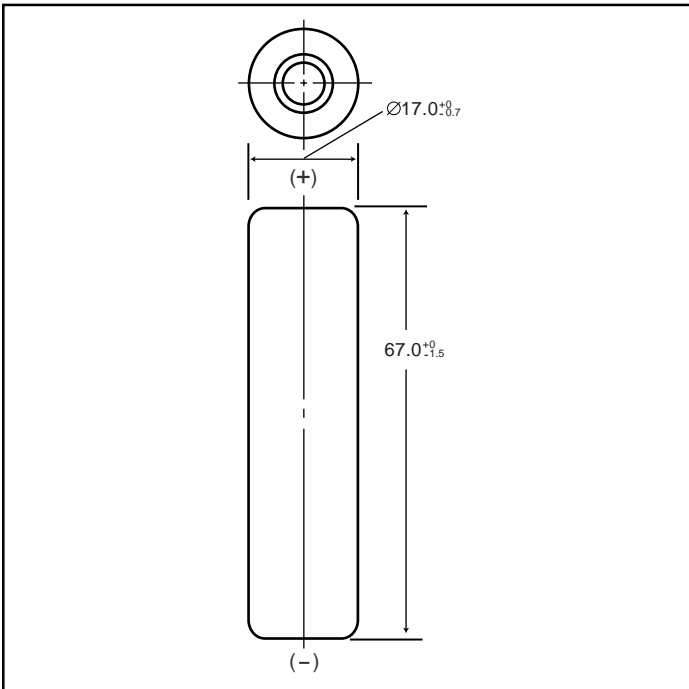

Typical Charge Characteristics

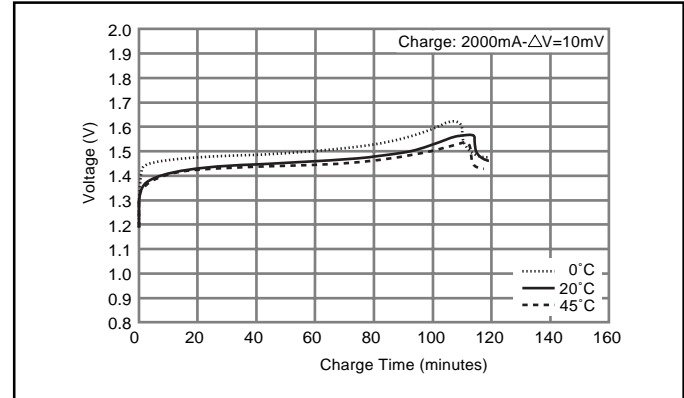

Typical Discharge Characteristics

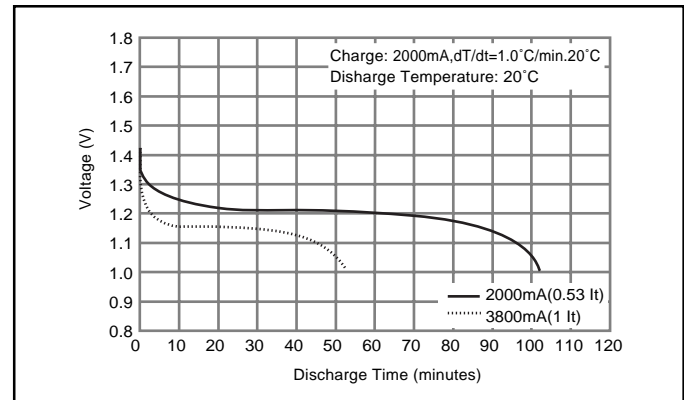
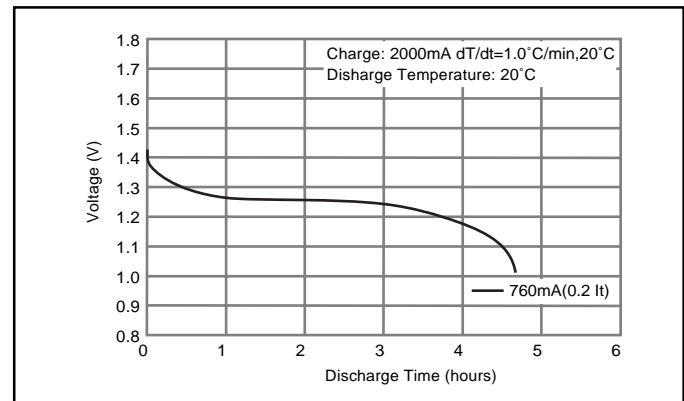

Specifications

	mm	inch
Diameter	17.0+0/-0.7	0.67+0/-0.03
Height	67.0+0/-1.5	2.64+0/-0.06
Approximate Weight	Grams	Ounces
	53	1.87

Nominal Voltage		1.2V		
Discharge Capacity*	Average**	3800 mAh		
	Rated (Min.)	3700 mAh		
Approx. Internal impedance at 1000Hz at charged state.		25mΩ		
Charge	Standard	370mA (0.1It) x 16hrs.		
	Rapid***	2000mA dT/dt		
Ambient Temperature	Charge	Standard	°C	
			°F	
	Discharge	Standard	0°C to 45°C	32°F to 113°F
		Rapid	0°C to 40°C	32°F to 104°F
Storage	< 1 year	-20°C to 35°C	-4°F to 95°F	
	< 3 months	-20°C to 45°C	-4°F to 113°F	
	< 1 month	-20°C to 55°C	-4°F to 131°F	

* After charging at 0.1It for 16 hours, discharging at 0.2It.

** For reference only.

*** For rapid charge: use dT/dt charge termination method. Refer to the Nickel Metal Hydride "Charge Methods" section for further details. Battery performance and cycle life are strongly affected by how they are used. In order to maximize battery safety, please consult Panasonic when determining charge / discharge specs, warning label contents and unit design.

Note: [It] was previously expressed as [C]. [It] is an IEC standard expression for the amount of charge or discharge current and is expressed as:

$$It(A) = C_n (Ah)/1h.$$

- [It] is the reference test current in amperes
- [C_n] is the rated capacity of the cell or battery in Ampere-hours.
- n = the time base [hours] for which the rated capacity is declared