

E-BAND UPCONVERTER SiP 81 - 86 GHz

Typical Applications

The HMC7585LG is ideal for:

- E-Band Communication Systems
- High Capacity Wireless Backhaul
- Test & Measurement

Functional Diagram

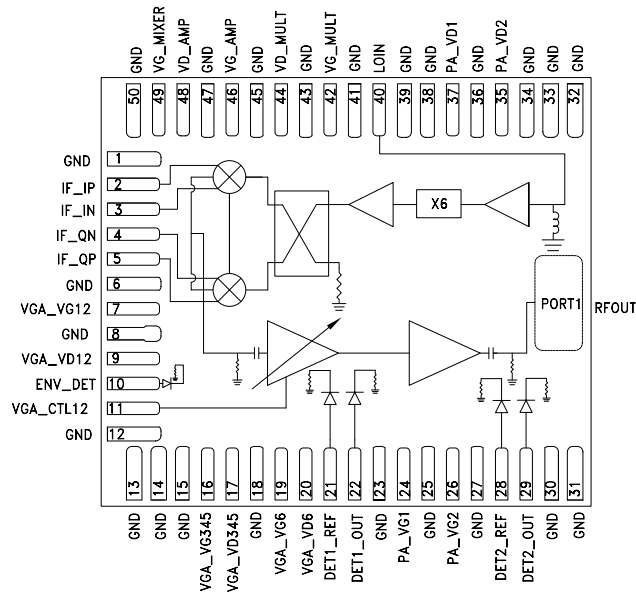

Features

- Conversion Gain: 32 dB typical
- Gain Control Range: 40 dB typical
- Saturated Output Power (P_{SAT}): 24 dBm typical
- Output Third-Order Intercept (IP3): 30 dBm typical
- Output Power for P1dB Compression: 23 dBm typical
- Built-in Power Detector
- Built-in Envelope Detector for local oscillator nulling
- Fully Integrated In Surface Mount 50-Lead 16 mm x 14 mm Package

General Description

The HMC7585LG is fully integrated System in Package (SiP) in phase/quadrature (I/Q) upconverter that operates from 81 GHz to 86 GHz. The device uses an image rejection mixer that is driven by a 6 × LO multiplier. A variable gain amplifier followed by a medium power amplifier are added to the mixer outputs to provide a small signal conversion gain of 32 dB typical. Differential I and Q mixer inputs are provided and can be driven with differential I and Q baseband waveforms for direct conversion applications. Alternatively, the inputs can be driven using an external 90° hybrid and two external 180° hybrids for single-sideband applications.

Electrical Specifications, $T_A = -40^\circ\text{C}$ to $+85^\circ\text{C}$, IF = 1000 MHz, LO = 4 dBm, VD_AMP = 4 V, VG_MIXER = -1 V, VD_MULT = 1.5 V, VGA_VD = 4 V, PA_VD = 4 V [1]

Parameter	Min.	Typ.	Max.	Units
RF Frequency Range	81		86	GHz
LO Frequency Range	13.4		14.6	GHz
IF Frequency Range	0		2	GHz
LO Input Level Range	0		8	dBm
Input Signal Level		-4		dBm
Conversion Gain (at Minimum Attenuation) @ -20 dBm Input		27.5 - 39		dB
Gain Tuning Range	40			dB
Sideband Rejection @ -4 dBm Input		20		dBc
Gain Flatness [2]		2		dB
Output Power for P1dB Compression (P1dB)				
At Gain = 23.5 dB		23		dBm

[1] Measurements performed as upconverter with upper sideband selected and one external 90° hybrid followed by two external 180° hybrids at the IF ports, unless otherwise noted.

[2] Measured over 1.6 GHz bandwidth.

E-BAND UPCONVERTER SIP 81 - 86 GHz

Electrical Specifications, $T_A = -40^\circ\text{C}$ to $+85^\circ\text{C}$, $IF = 1000\text{ MHz}$, $LO = 4\text{ dBm}$, $VD_AMP = 4\text{ V}$, $VG_MIXER = -1\text{ V}$, $VD_MULT = 1.5\text{ V}$, $VGA_VD = 4\text{ V}$, $PA_VD = 4\text{ V}$ [1]

Parameter	Min.	Typ.	Max.	Units
Saturated Output Power (P_{SAT})				
At Gain = 23.5 dB		24		dBm
Noise Figure				
At Gain = 23.5 dB		21.5		dB
6 x LO to RF Output Rejection (RF Port uncalibrated)				
At Gain = 23.5 dB		8		dBc
Output Third-Order Intercept (OIP3)				
At Gain = 23.5 dB (at $P_{out} = 16.5\text{ dBm/tone}$)		30		dBm
Output Waveguide Port Return Loss		10		dB
Baseband Input Port Return Loss		10		dB
LO Input Port Return Loss		10		dB
PA Detector ($V_{ref} - V_{det}$) Voltage ($-3 \leq P_{out} \leq 23\text{ dBm}$)		0.015 to 2		V
Envelope Detector Bandwidth		750		MHz
DC Power Dissipation		3.62		W
VD for the PA		4		V
VG for the PA	-2		0.2	V
VG for the VGA	-2		0.2	V
VD for the Multiplier (VD_MULT)	1.46	1.5	1.55	V
Voltage Control	-5		0	V
Output Waveguide Port		WR-12		
Differential Input Port Impedance		100		Ohm
LO Input Port Impedance		50		Ohm

[1] Measurements performed as upconverter with one external 90° hybrid followed by two external 180° hybrids at the IF ports, unless otherwise noted.